

Illusion
Gas Log Fires

PROUDLY
AUSTRALIAN MADE



Matrix

Medium GAS LOG FIRE



Introducing the Matrix Medium Gas Log Fire by Illusion, Australia's foremost manufacturer of Gas Log Fires.

The Matrix Medium features stylish design & powerful performance combined with class leading realistic logs making it the perfect choice to keep medium sized areas warm and comfortable in your home without breaking the budget.

Capable of heating up to 90 sq metres, the stunning Illusion Matrix Inbuilt Gas Log Fires are available in a range of colours including Metallic Black with several trim options designed to suit any decor.

INBUILT GAS LOG FIRES BY ILLUSION

Australia's Leading Gas Log Fire Manufacturer

CERTIFICATION



Certificate Holder: Illusion Australia Pty. Ltd.
145 South Gippsland Hwy.
Dandenong South Vic 3175
ABN: 35005 834 784
Manufacturer: A.G.Building Developments Pty. Ltd.

Certificate Numbers:
GMK 10360 (NG) & 10361 (LPG)
Issue Date: 21/7/2017

Distributor:	Brand Name:	Model ID:	Gas Type	MJ/h
ILLUSION	MATRIX	MEDIUM VERTICAL	NATURAL	34
ILLUSION	MATRIX	MEDIUM VERTICAL	LPG	34
ILLUSION	MATRIX	MEDIUM HORIZONTAL	NATURAL	34
ILLUSION	MATRIX	MEDIUM HORIZONTAL	LPG	N/A

All Illusion Matrix Gas Log Fires have been tested and approved to AS: 4558

Ron Chisney Chief Executive Officer of the IAPMO Group
This GasMark Schedule supersedes all previously issued Schedules

DIMENSIONS

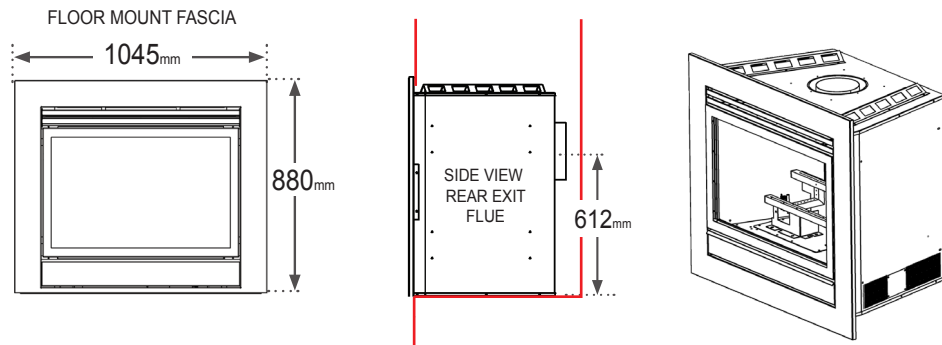
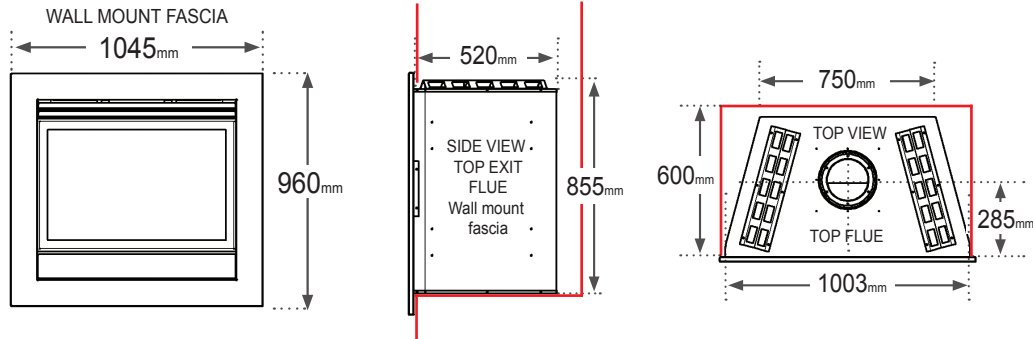

Please note: Matrix gas log fires fascias are available as either wall mounted or floor mounted. See above drawings for fascia sizes.
The Flue system must be installed by an Authorised installer.
Some installations may require the provision of a hearth to protect the floor from radiant heat. Contact your Illusion dealer for more information.

FRAME CUTOUT

MATRIX MEDIUM Frame and plaster cutout dimensions.
NOTE: Minimum frame depth 600mm.
Example Wall mount shown below.

The frame and plaster cutout dimensions as shown above should be cut as accurately as possible to ensure adequate coverage by the appliance fascia. Illusion can supply fabricated full metal frames to simplify the installation and reduce costs.

The cutout dimensions (Shown at right) are the same for both the Wall mounted or floor mounted versions of the Matrix Gas Log Fire.

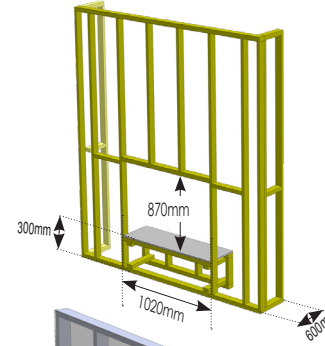

The wall mounted Matrix fascia must be 250mm or more above the floor to prevent damage from radiant heat.

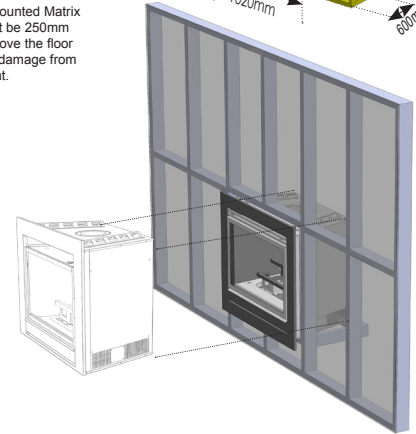

A Hearth is required for the floor mounted version. The hearth must extend 150mm past either side of the fascia sides and must be constructed of non combustible materials.

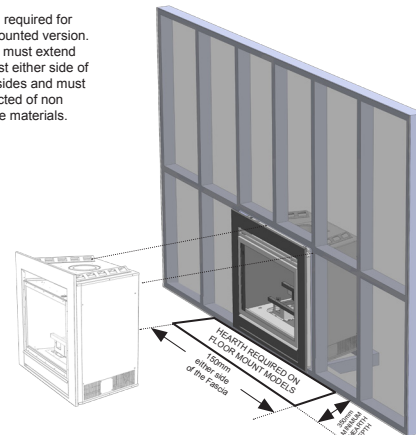

INSTALLATION

EXAMPLE MATRIX MEDIUM VERTICAL INSTALL

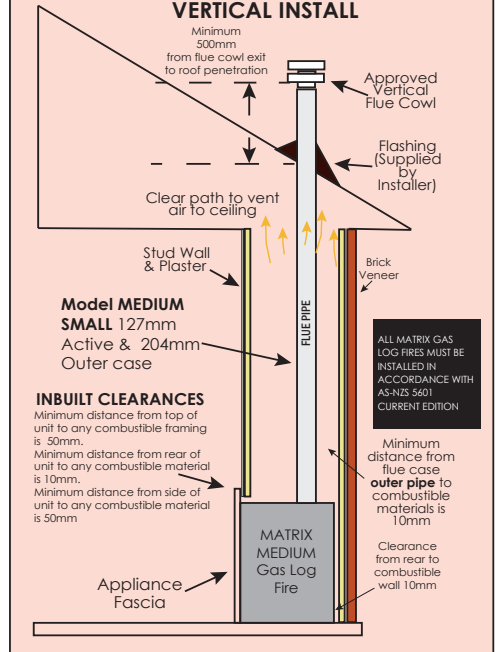

ALL MATRIX GAS LOG FIRES MUST BE INSTALLED IN ACCORDANCE WITH AS-NZS 5601 CURRENT EDITION

EXAMPLE MATRIX MEDIUM HORIZONTAL INSTALL

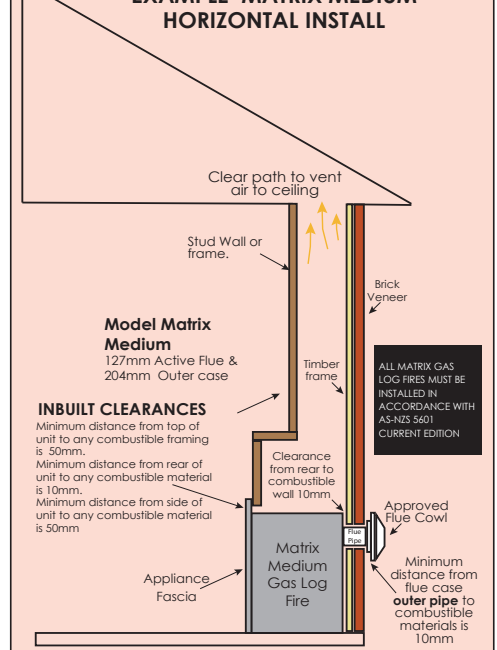

ALL MATRIX GAS LOG FIRES MUST BE INSTALLED IN ACCORDANCE WITH AS-NZS 5601 CURRENT EDITION



www.illusionfires.com.au
The dimensions, etc quoted here are correct at the time of writing but may be subject to change. Please check with your dealer before commencing any building works or installations of these appliances.
A slight reduction in performance may result if high ceilings, large glass areas or lack of insulation are present. Ultimate reserves the right to alter specifications without notice. Photos are for illustrative purposes only. Some colours may vary due to the printing process.

