

**FEM2600NM (FEM3500) / FEM2600M (FEM3500M) / FEM2600DNM (FEM3500D) / FEM2600DM (FEM3500DM) / FEM2603M (FEM3500FM)**

HIGH QUALITY STANDARD ELECTRO MAGNETIC LOCKING DEVICES  
SINGLE/DOUBLE DOOR SURFACE MOUNT



FEM3500 SERIES

**PRODUCT DESCRIPTION**

The FEM3500 is an unmonitored single magnetic lock and FEM3500D is an unmonitored double magnetic lock with dual 12 or 24 Volt settings.

The FEM3500M is a monitored single magnetic lock and the FEM3500DM is a monitored double magnetic lock both with 12 or 24 Volt settings. Each monitored magnetic lock has a built-in Hall Effect Sensor for remote monitoring of Lock status (LSS). The devices have a highly visible high luminosity Light Panel and a Door Status Sensor (DSS) for remote monitoring of the door status as well as Lock Status Sensor (LSS). The monitored devices come with a patented Anti-Tamper-Security-Plate as standard to prevent hostile attacks on the dome-nut-fixing bolt of the Armature Plate.

All FEM3500 Series Electro Magnetic Locks come with a lifetime warranty and have no residual magnetism.

**TECHNICAL DETAILS**

PART NO.	FEM3500(Single) FEM3500D(Double)	FEM3500M(Single) FEM3500DM(Double)	FEM3500FM (Flush Mounted)
HOLDING STRENGTH	Up to 280kg		
VOLTAGE/CURRENT	Dual Voltage 12/24VDC, 12VDC= 500mA (Double x2) 24VDC= 250mA (Double x2)		
APPROVALS	4 hour fire rated to A.S. and B.S. standards		
MONITORING	NIL	LP LSS DSS	LSS
SIZE	Single door series magnet size: L= 238 x W= 48 x D= 25mm Single door series armature plate size: L= 185 x W= 38 x D= 12mm Single door series DSS-armature plate size: L= 185 x W= 38 x D= 12mm	Double door series surface magnet size: L= 477 x W= 48 x D= 25mm Double door series armature plate size: L= 185 x W= 38 x D= 12mm x 2 pcs Double door series DSS-armature plate size: L= 185 x W= 38 x D= 12mm x 2 pcs	

**PRODUCT FEATURES**

- Door and Lock Status Monitoring Sensor (DSS & LSS)
- Built-in varistor (MOV) surge protection
- CE/C-Tick
- Anti Tamper Plate (with "M" Models)
- Long distance Light Panel (LP)
- Lifetime warranty
- 4 hour fire tested
- Guaranteed no residual magnetism

**PRODUCT DIMENSIONS AND INSTALLATION**

FEM3500D & FEM3500DM

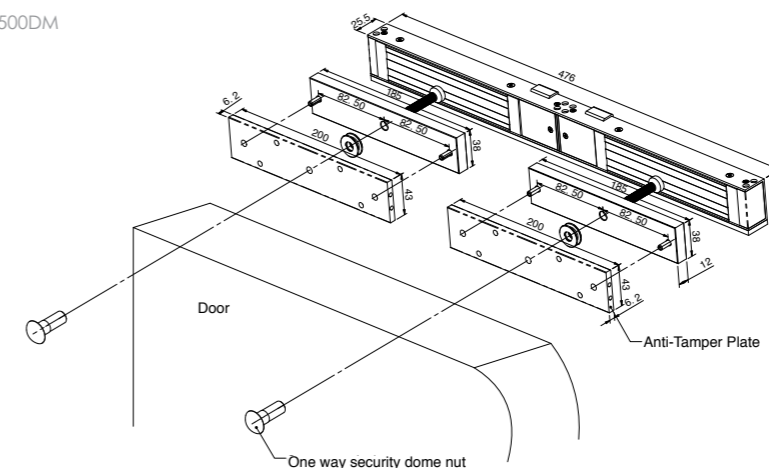

FEM3500 & FEM3500M

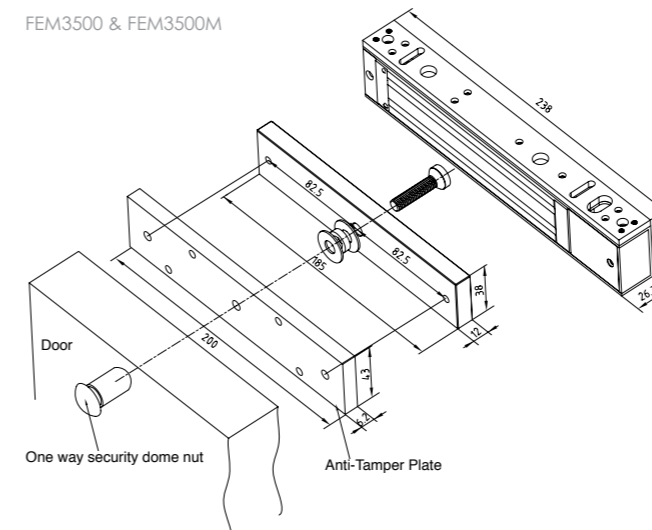

FEM3500FM

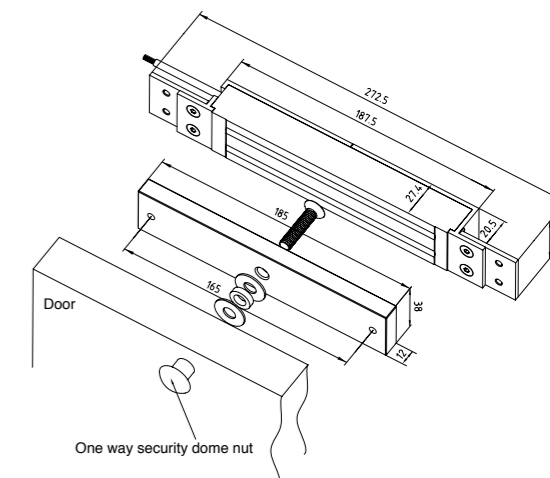

**seadan** security & electronics



VIC Unit 7, 170 Forster Road, Mt Waverley VIC 3149  
NSW Unit 5, 142 James Ruse Drive, Parramatta NSW 2150  
QLD 15-19 Hudson Road, Albion QLD 4010  
WA Unit 4, 200 Balcatta Road, Balcatta WA 6021  
ACT Unit 2, 157-161 Gladstone Street, Fyshwick ACT 2609

You're in very secure company 1300 366 851 | [seadan@seadan.com.au](mailto:seadan@seadan.com.au)