

Ø 3mm Wire Rope Installation Instructions



PRO-RAILING®
The Stainless Steel Handrail Component System

Wire Rope Systems

As part of our Pro-Railing® range of products, we have six wire rope options for you to choose from. Wire rope can be used to offer a long-lasting, contemporary appearance to your balustrade or handrail project. Wire rope systems are also perfect for offices and industrial use and are available with Ø 3mm options.

To make life easy we offer the choice of using our pre-assembled or make your own posts. The wire can be passed through or fixed to the front face of the posts. Our comprehensive instructions are designed to assist in your selection of the perfect system for your project.

Measuring and Cutting Wire	Page 3
System 1 - Swageless In Line System Using Pre-Assembled Posts	Page 4
System 2 - Swaged In Line System Using Pre-Assembled Posts	Page 8
System 3 - Swageless In Line System Using Bespoke Posts	Page 12
System 4 - Swaged In Line System Using Bespoke Posts	Page 16
System 5 - Swageless In Line System Using Bespoke Posts	Page 20
System 6 - Swaged In Line System Using Wooden Posts	Page 24
How to finish on a wall and use our post fitting adaptor ring	Page 27
Bespoke Posts	Page 28
Care & Maintenance	Page 29

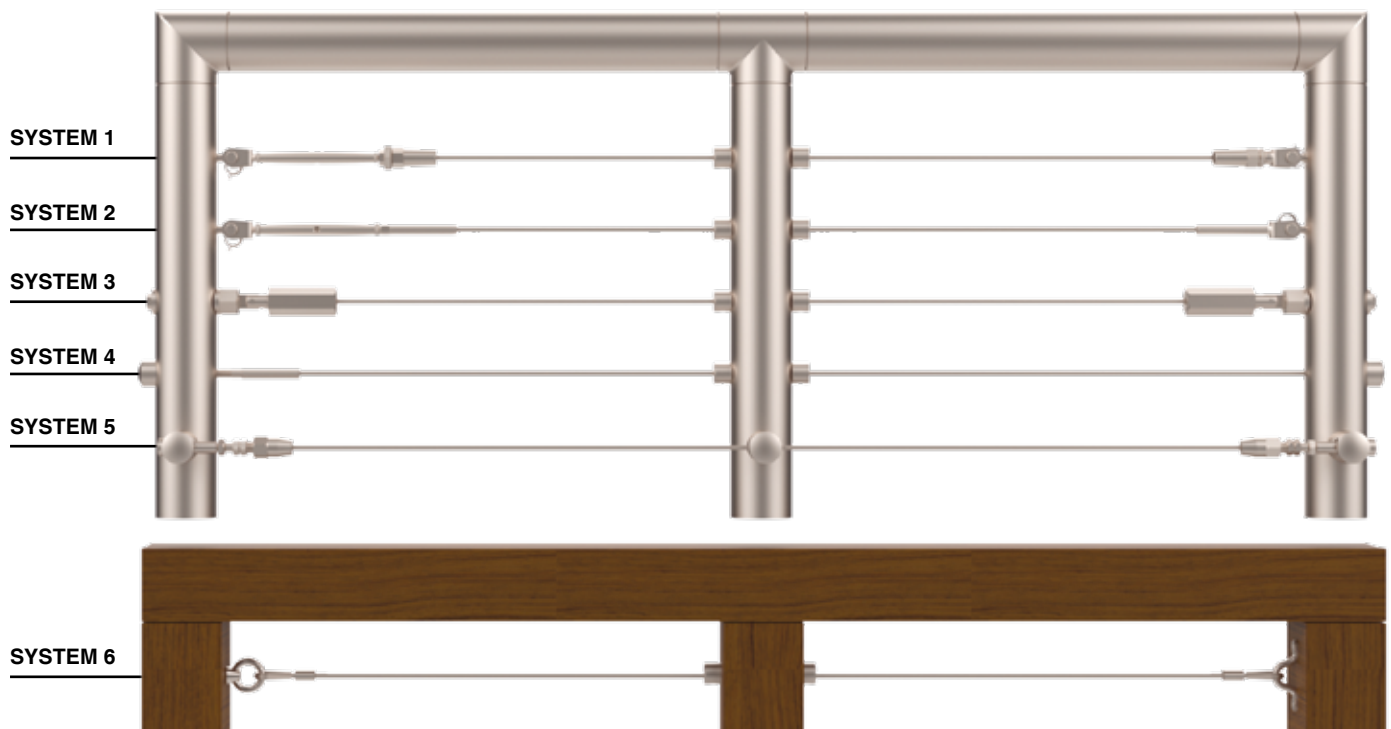

Disclaimer: Please note, that we cannot give accurate measurements on cutting instructions as we do not know the exact situation of installation. F.H. Brundle holds no responsibility for any errors made in installation and we advise you take caution in installation.

Great care should be taken not to contaminate new stainless steelwork during installation. Any work carried out in the vicinity should be done with due consideration to the care of the stainless steel product and it should not come into contact with mild steel.

In addition to knowing which of our components to use to create a wire rope system, it is equally important to know how to properly measure the wire to create the right amount of tension. Below are a few suggestions you might like to try when measuring and cutting the wire to fit different systems.

The diagram below applies for systems that require crimping, also known as ‘swaged’. The wire will need to be roughly measured beforehand, on a clean, flat surface, as once the component is crimped you will be unable to remove the wire from the component. Therefore, it is important to get a rough idea of the length of wire you will require. Measure the length of a run from the inside of the start post to the corresponding side on the end post and allow a little extra. When your termination post is a corner, always over estimate when measuring wire.

Swaged Systems (requires crimping or gluing) - Systems 2, 4 and 6

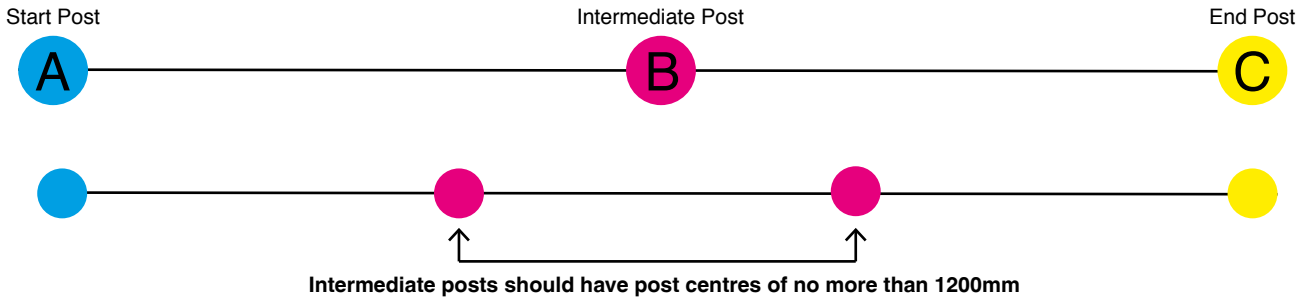

With the swaged systems, you have two options. On the swaged nozzles, you can either swage (crimp) the nozzles with the hydraulic crimping tool (code: **189900102**) or manual crimping tool (code: **189900103**), alternatively fill the nozzles with instant adhesive (code: **1899007454**) and stick the wire in the nozzle.

Cutting the Wire

A tip we suggest when measuring the wire, on swaged systems, is to mark with tape. Mark the ‘cut line’ on the edge of the tape, and putting the excess of tape on the excess wire so that if you cut the wrong end of the tape, your wire will not be too short. We recommend using our wire cutting tool (code: **080569**) when cutting the wire. If the wire frays after cutting, simply twist in the direction of the wire and it will go back into place.

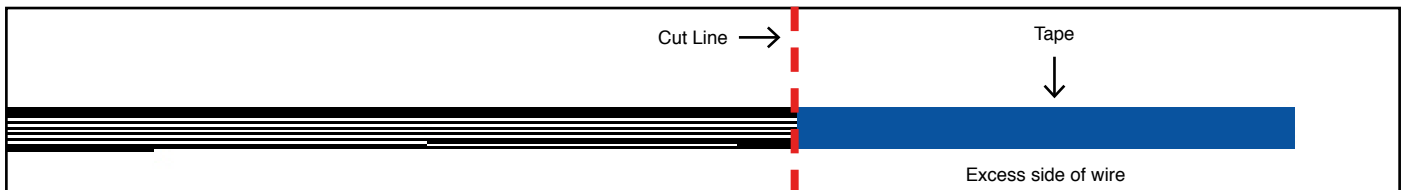

Swageless Systems (no crimping required) - Systems 1, 3 and 5

When measuring and cutting the wire for swageless systems that do not require crimping, refer to individual instructions on where to cut the wire. Our swageless systems can be refitted if required using our handy release tool (code: **1806620**) which has been designed to remove the wire if an error has been made or the wire is too long to tension correctly. As this option is available for the swageless systems, it does not require the same steps as above for the swaged method, and can be marked with a pen for quick assembly. Look out for the  symbol when knowing when to measure and cut. We recommend using our wire cutting tool (code: **080569**) when cutting the wire and if the wire frays after cutting, simply twist in the direction of the wire and it will go back into place.

ID	Description	Code
1	Wire Rope	180660510 / 180660550 / 1806605100
2	Release Tool	1806620
3	Swageless Component	-

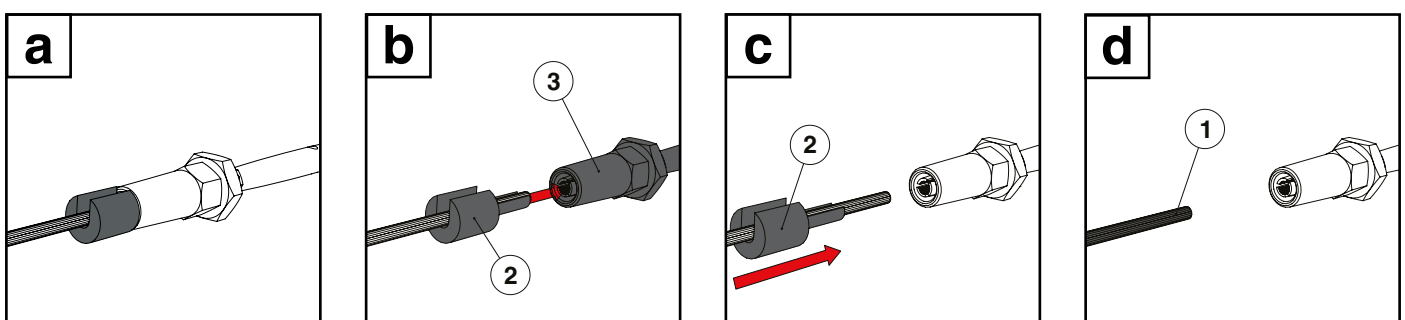

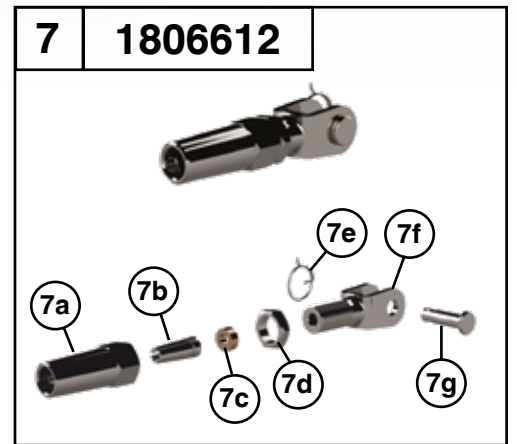
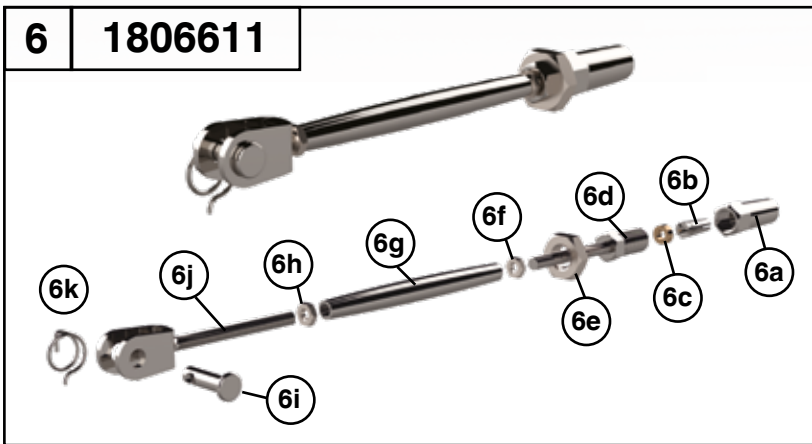
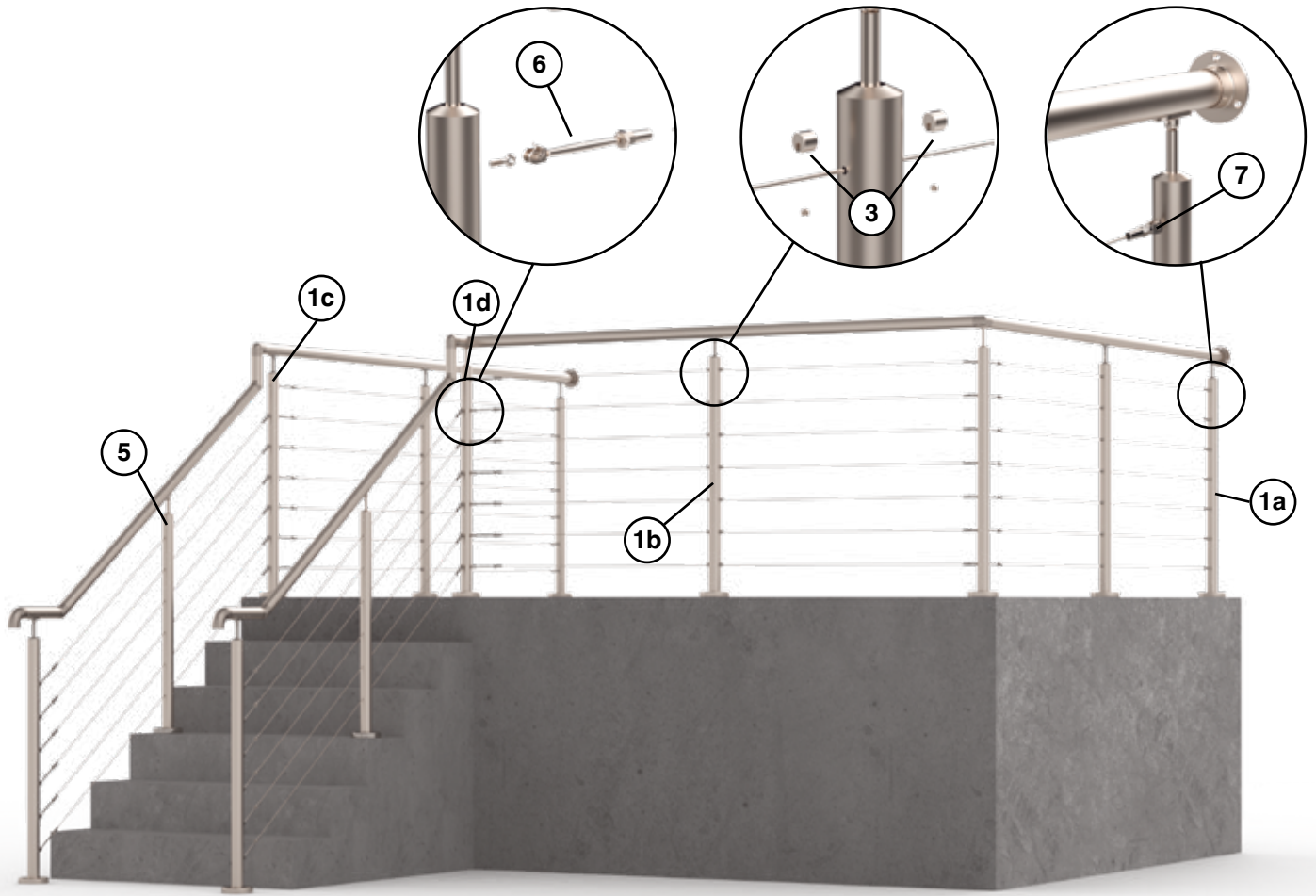









System 1 Components

ID		Description	Size	To Suit Wire Ø mm	Code
1	a	7 Hole End/Mid Posts (M6 Eyebolts)	Ø 48.3mm	3	1806741D
	b	14 Hole Mid Straining Post (M6 Eyebolts)			1806742D
	c	14 Hole Mid Post (6mm Through Holes)			1806742DT
	d	14 Hole Corner Posts (M6 Eyebolts)			1806743D
2	Wire Rope		10m	3	180660510
			50m	3	180660550
			100m	3	1806605100
3		Locking Collar	N/A	3	1806604
4		Eyebolt Connector	M6	3	1806603
5		Bespoke Posts (see page 28)	Ø 48.3mm	3	-
6		Swageless Cable Tensioner	N/A	3	1806611
7		Swageless Buckle	N/A	3	1806612

All components are stainless steel Grade 316.

N.B. This system can be used with our Post Adapter ring. For more information please refer to page 28.

Description	Symbol	Information
Drill		To pre-drill and tap posts to suit components
Saw		For cutting posts when building your own posts for straights or rakes
Crimping Tool		Use either Crimping Tool (code: 1899001102) or Hydraulic Crimping Tool (code: 189900103)
Wire Cutting Tool		To trim wire use code: 080569
Instant Adhesive		Use (code: 1899007454) as an instant adhesive gel for uniform stress distribution. Supplied with plunger for accurate application
Allen Key		To fix grub screws into locking collar (code: 189900606)
Spanner		To tighten nuts in wire rope components
Screwdriver		To tighten and create tension in the wire

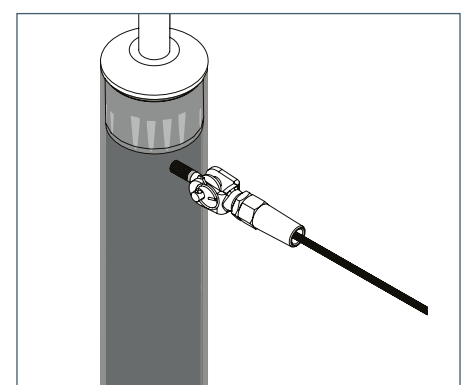
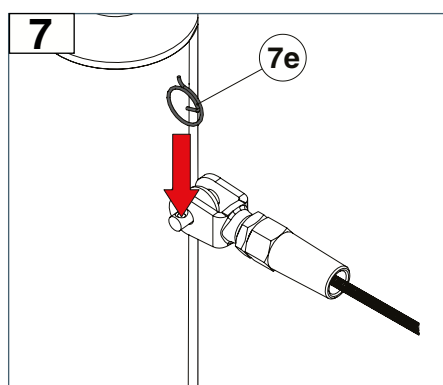
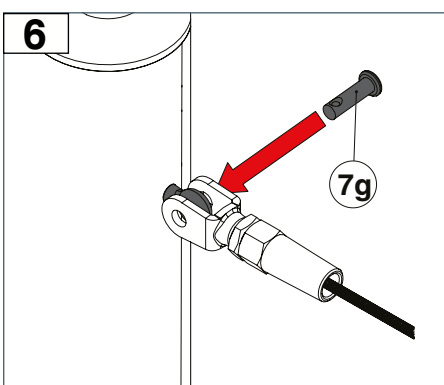
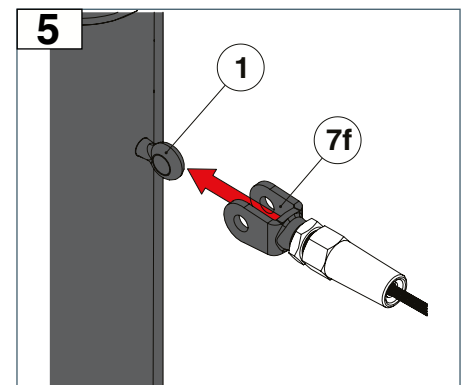
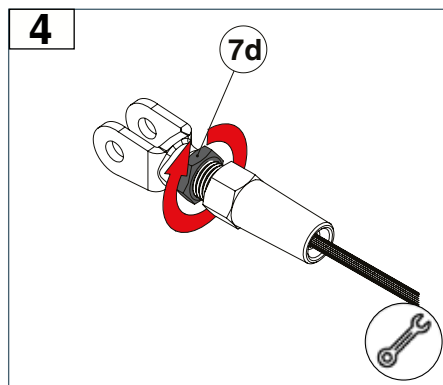
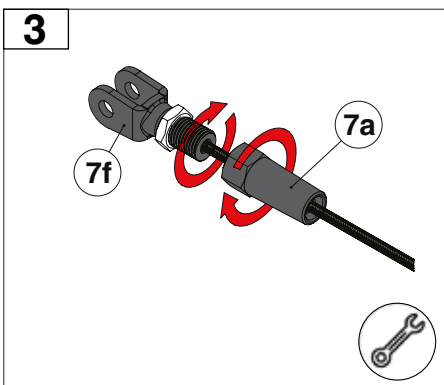
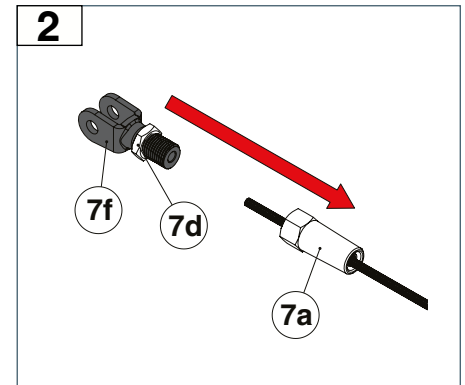
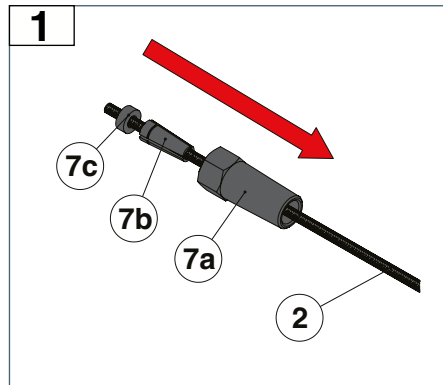
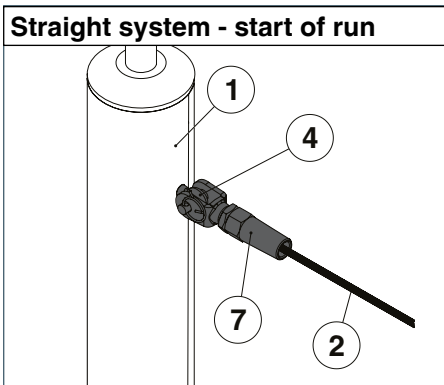

Straight system - intermediate

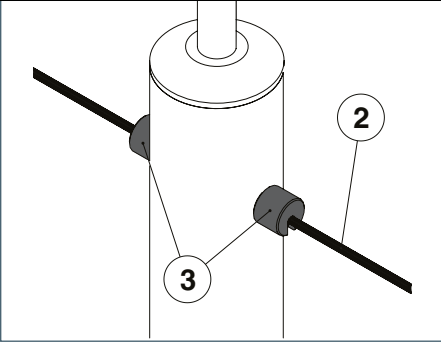

8

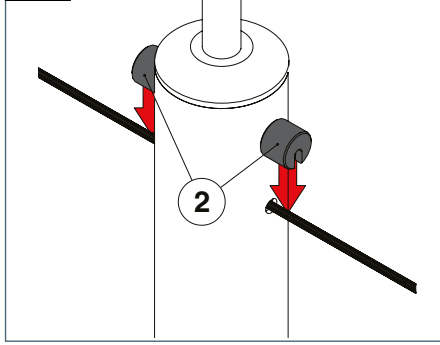

9

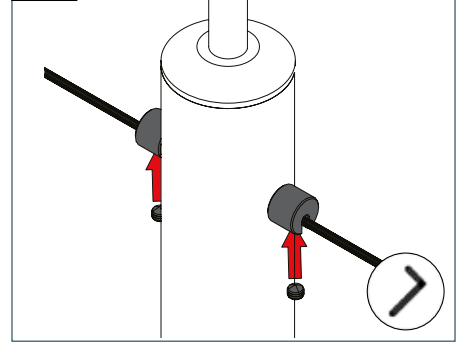

Loosely fix the locking collars between the intermediate posts and tighten at end.

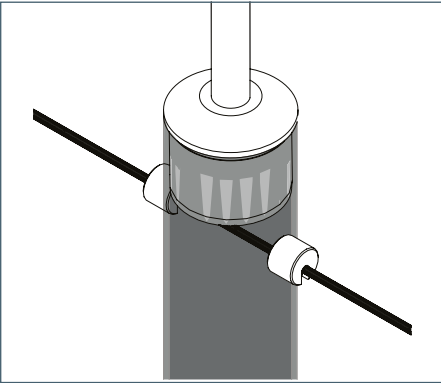

Straight system - end of run

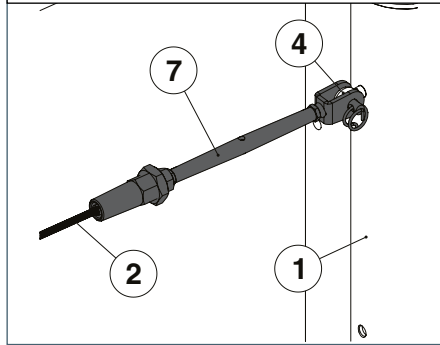

10

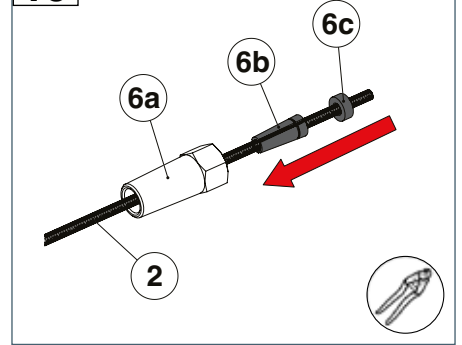

Measure with components up to post and cut the wire to a rough estimate.

11

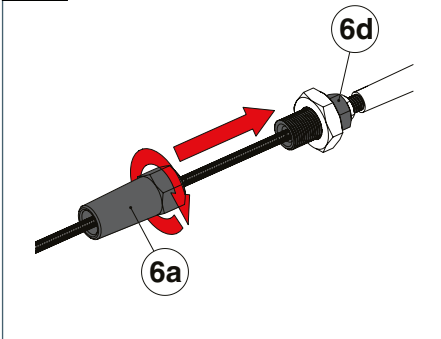

12

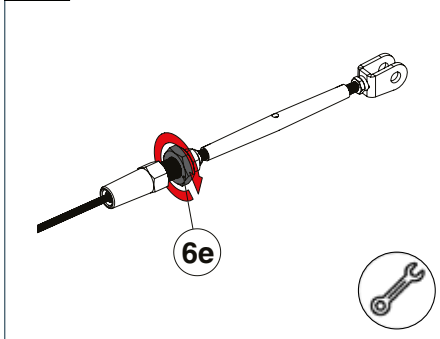

13

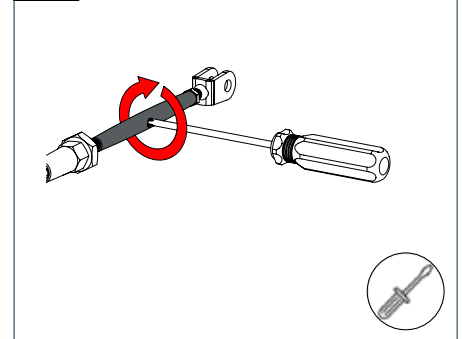

14

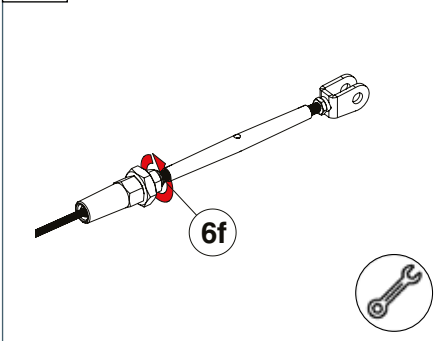

15

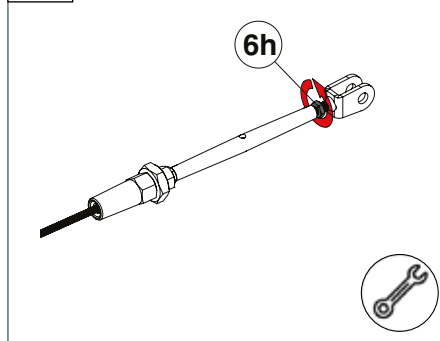

16

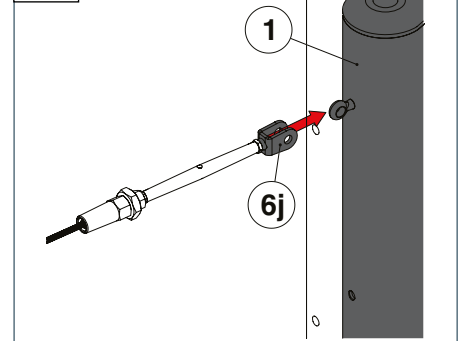

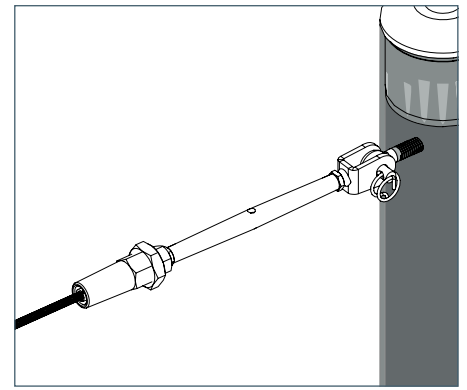
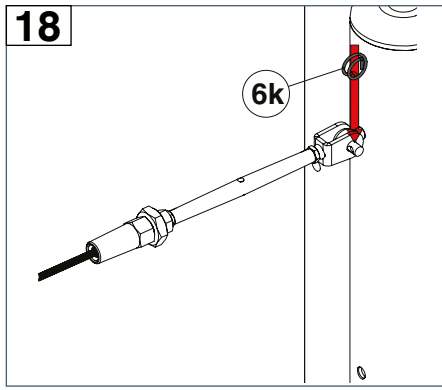
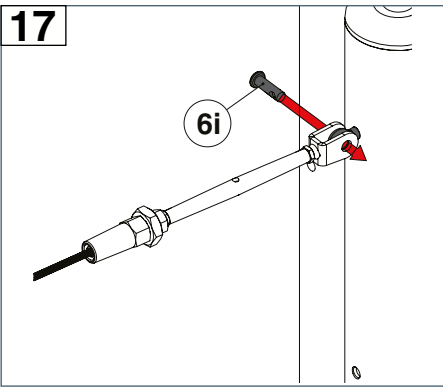

If tension is not correct after intermediate wires have been tightened. Use release tool, cut wire and redo.

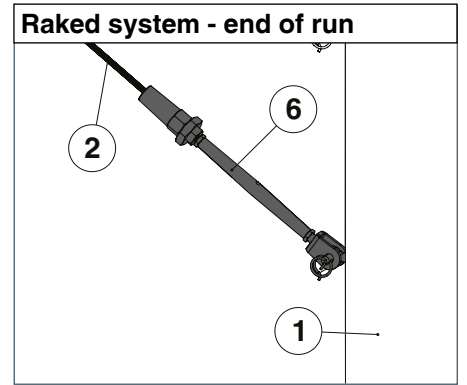
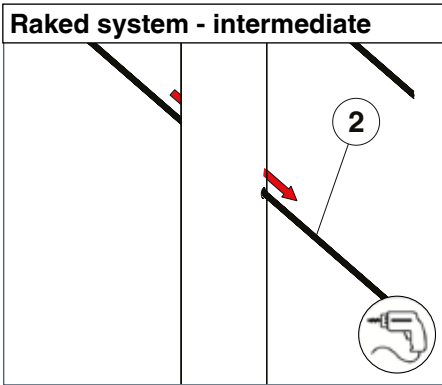
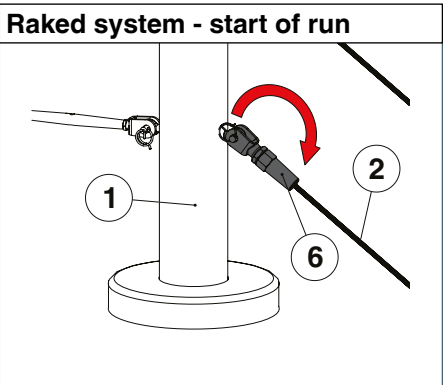

To create bespoke posts, please refer to page 28.

If tension is not correct after wires have been tightened. Use release tool, cut wire and redo.

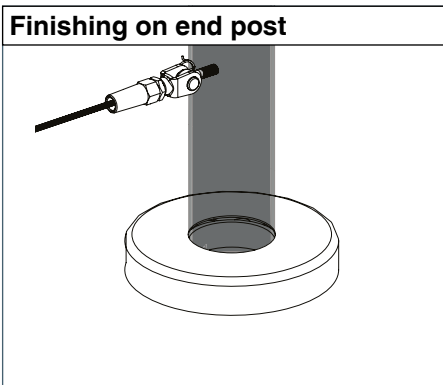
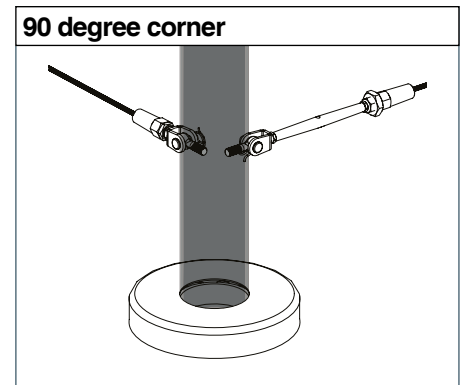
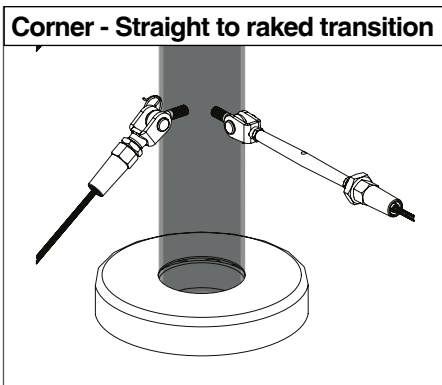
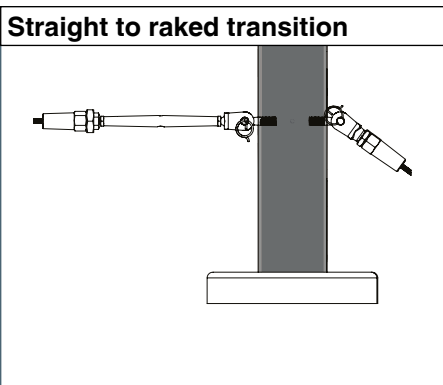

For finishing up to a wall, see page 27.

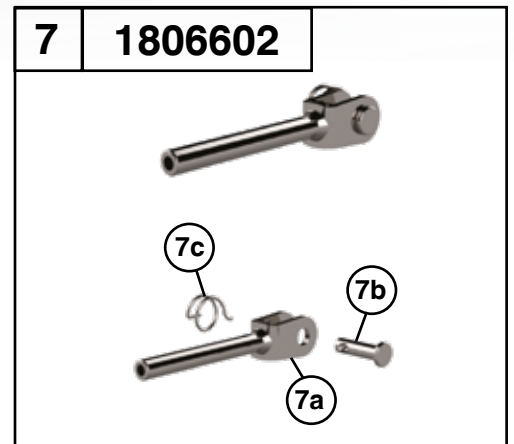
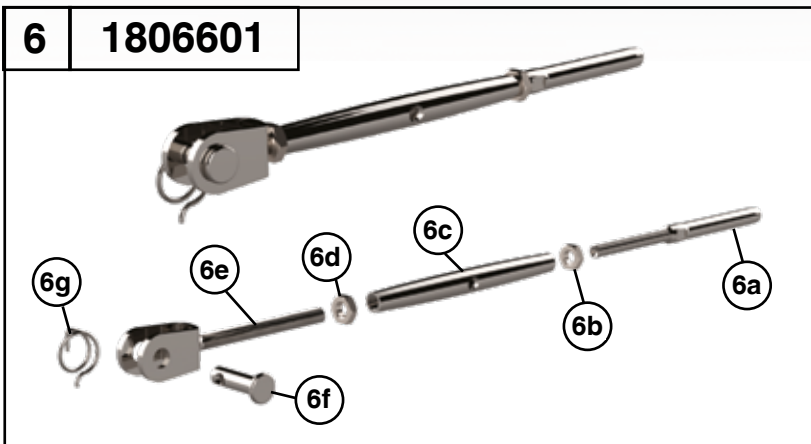
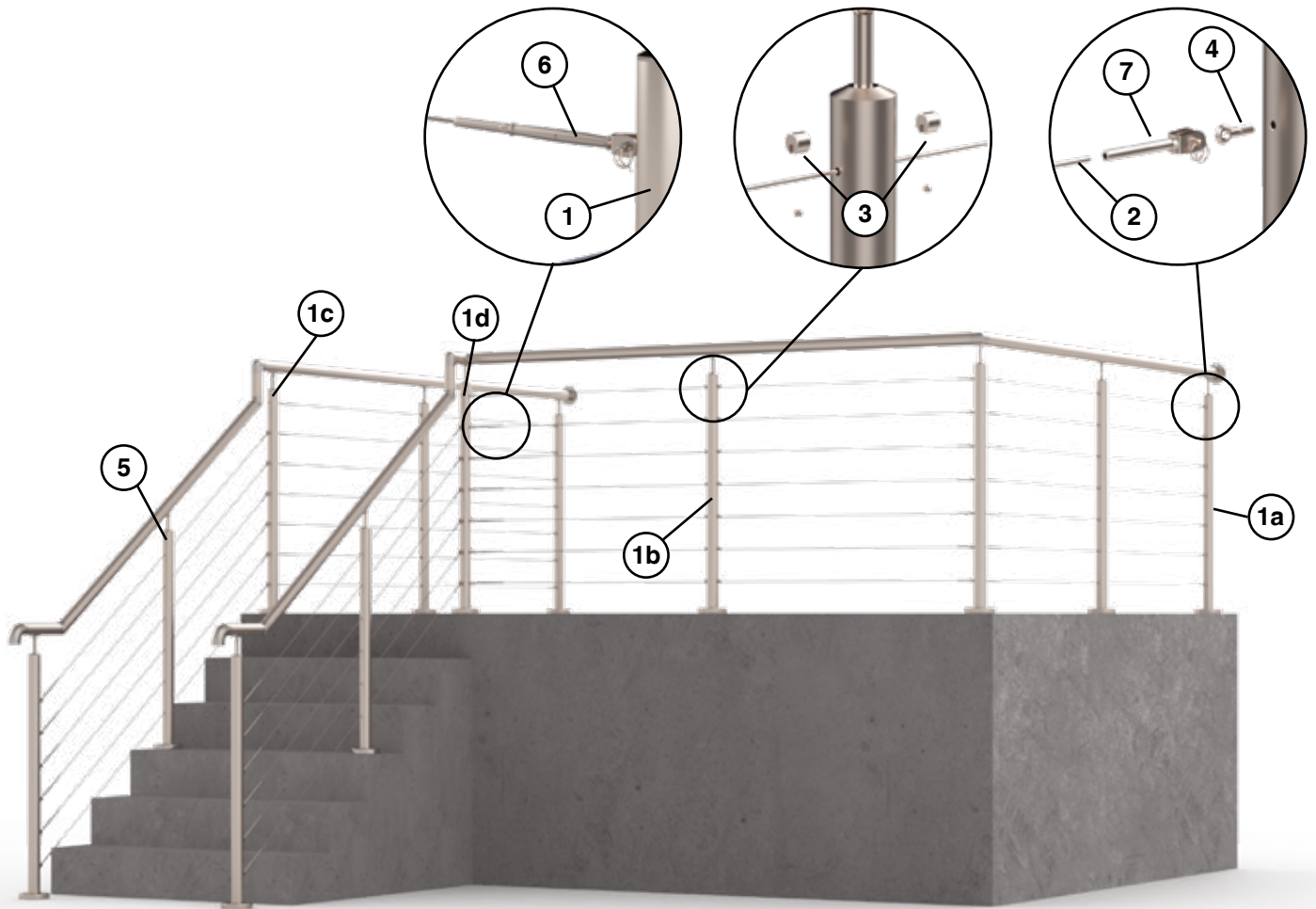









System 2 Components

ID		Description	Size	To Suit Wire Ø mm	Code
1	a	7 Hole End/Mid Posts (M6 Eyebolts)	Ø 48.3mm	3	1806741D
	b	14 Hole Mid Straining Post (M6 Eyebolts)			1806742D
	c	14 Hole Mid Post (6mm Through Holes)			1806742DT
	d	14 Hole Corner Posts (M6 Eyebolts)			1806743D
2	Wire Rope	10m	3	180660510	
		50m	3	180660550	
		100m	3	1806605100	
3		Locking Collar	N/A	3	1806604
4		Eyebolt Connector	M6	3	1806603
5		Bespoke Posts (see page 28)	Ø 48.3mm	3	-
6		Swaged Cable Tensioner	N/A	3	1806601
7		Swaged Buckle	N/A	3	1806602

All components are stainless steel Grade 316.

N.B. This system can be used with our Post Adapter ring. For more information please refer to page 28.

Description	Symbol	Information
Drill		To pre-drill and tap posts to suit components
Saw		For cutting posts when building your own posts for straights or rakes
Crimping Tool		Use either Crimping Tool (code: 1899001102) or Hydraulic Crimping Tool (code: 189900103)
Wire Cutting Tool		To trim wire use code: 080569
Instant Adhesive		Use (code: 1899007454) as an instant adhesive gel for uniform stress distribution. Supplied with plunger for accurate application
Allen Key		To fix grub screws into locking collar (code: 189900606)
Spanner		To tighten nuts in wire rope components
Screwdriver		To tighten and create tension in the wire

NB: For the swaged nozzles you can either crimp the nozzles OR fill the nozzles with glue and stick the wire into the nozzle.

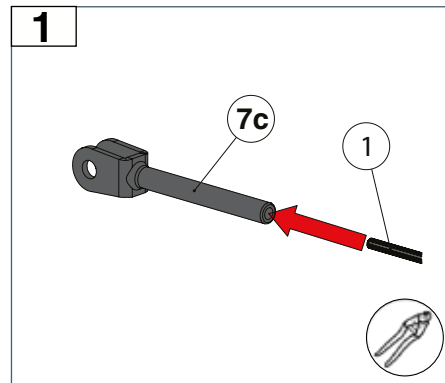
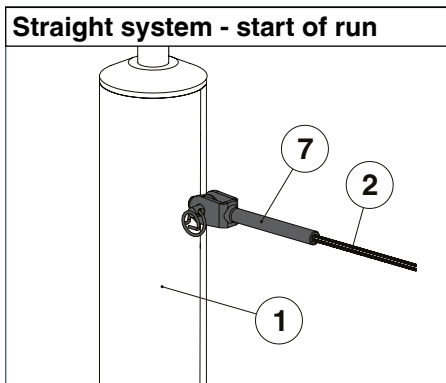

Measure on a flat surface and cut the wire.

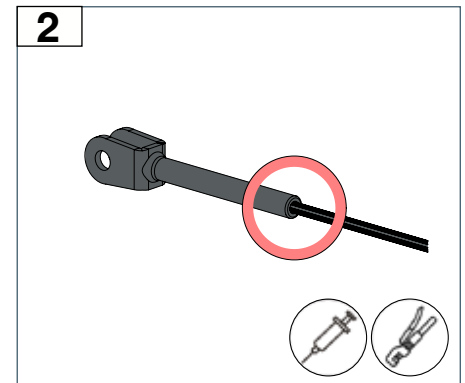

Crimp or glue 2 into 7a.

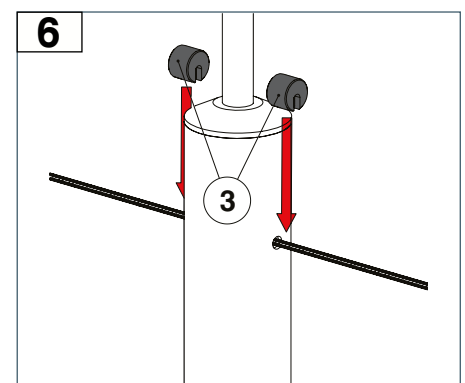
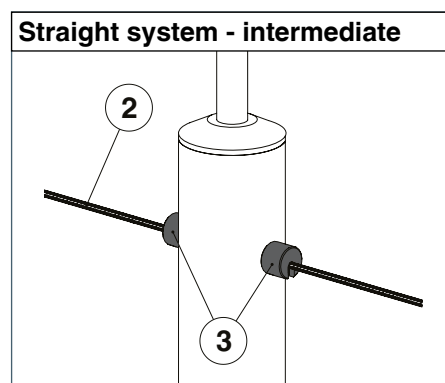
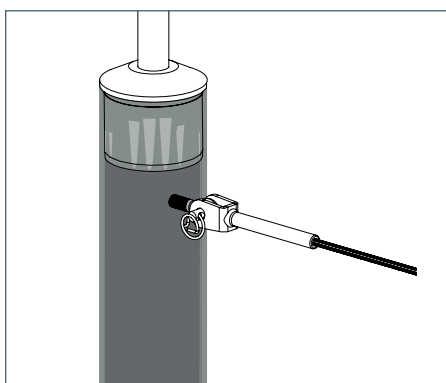
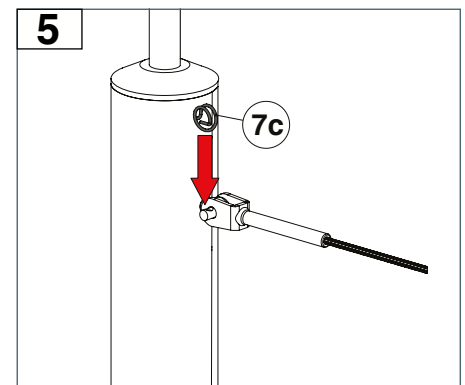
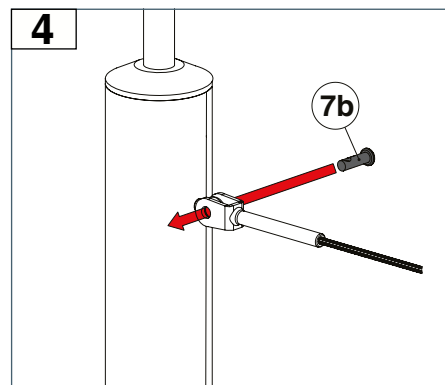
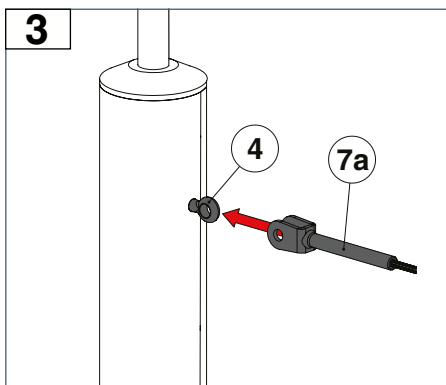

Loosely fix the locking collars between the intermediate posts and tighten at end.

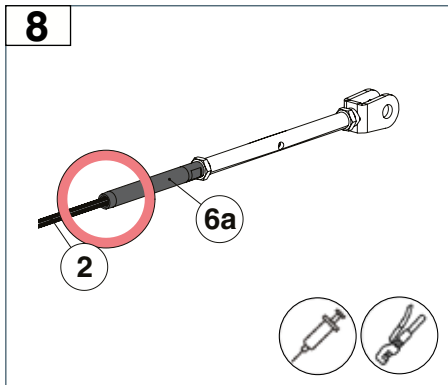
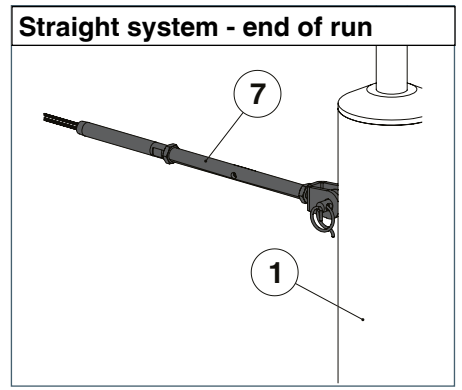
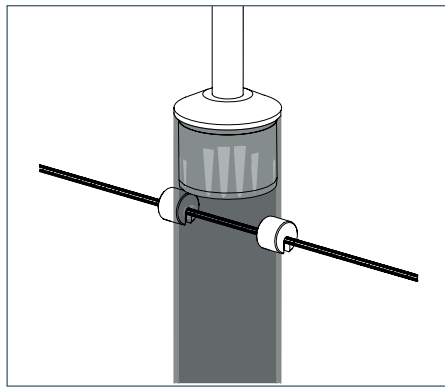
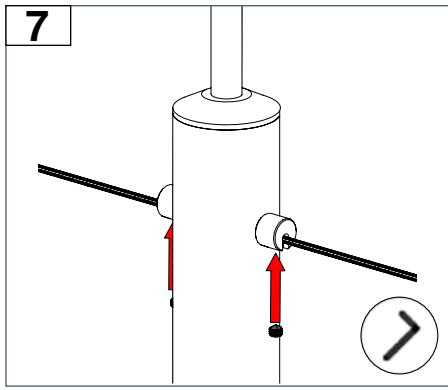

Crimp or glue 2 into 6a.

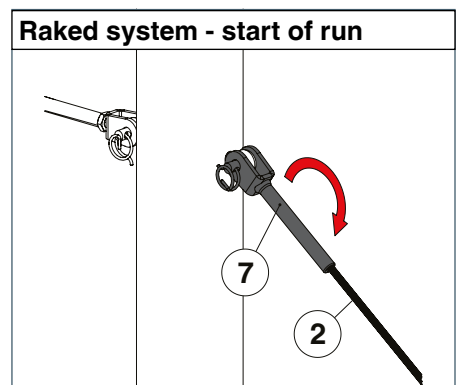
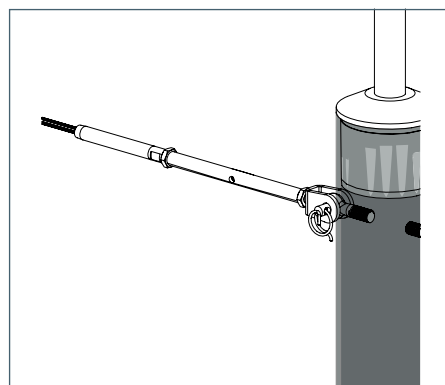
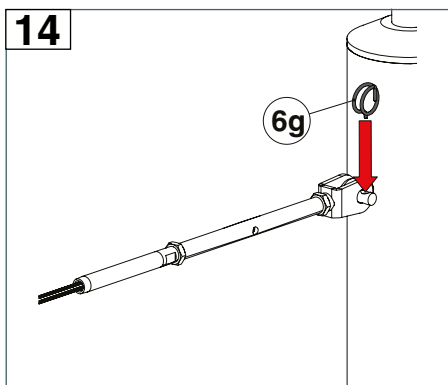
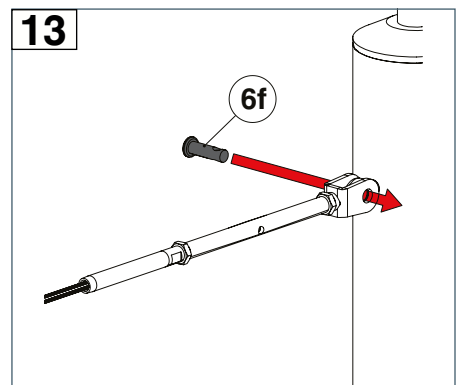
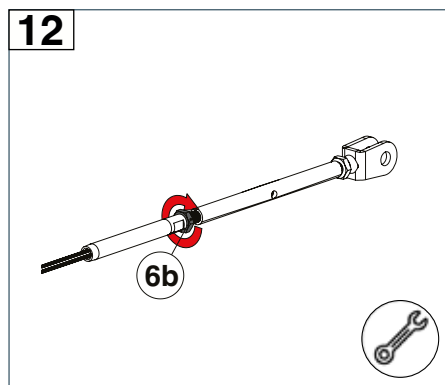
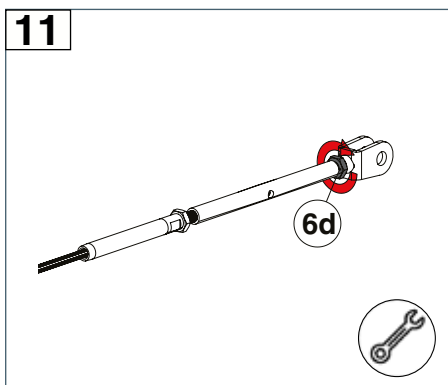
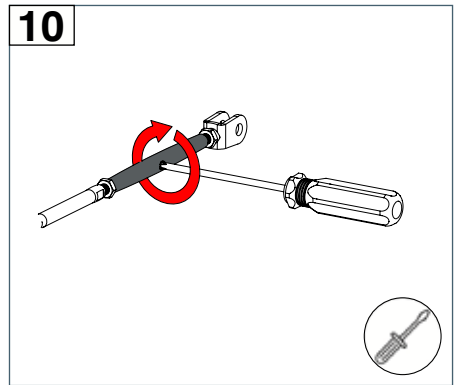
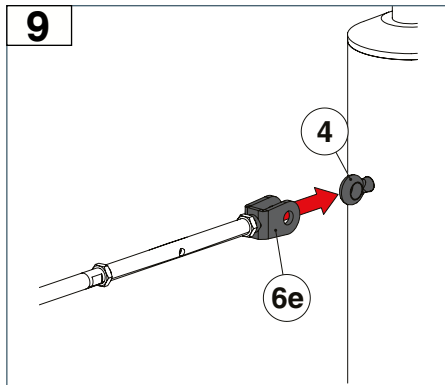

Tighten and tension locking collars on intermediate posts.

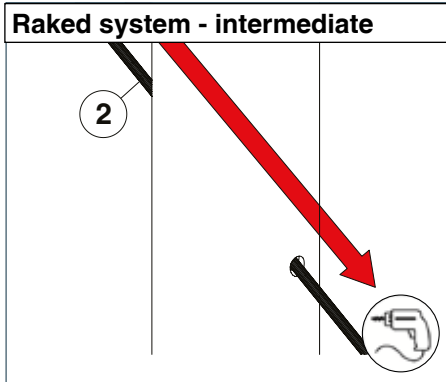

Drill Ø 6mm hole through post on an angle for wire to thread through.

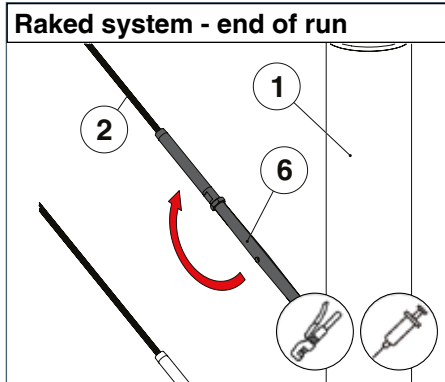

Once wires have been tightened you can crimp or glue to fix.

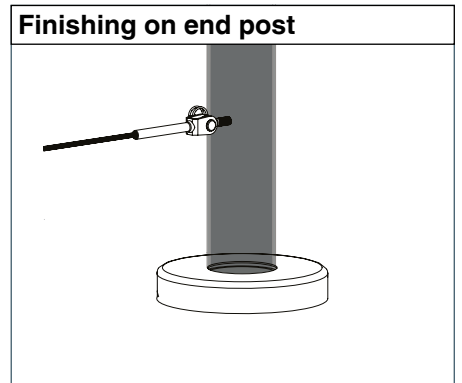
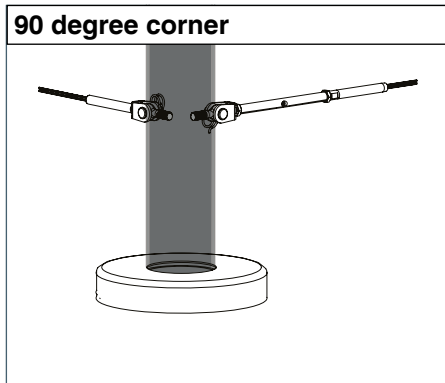
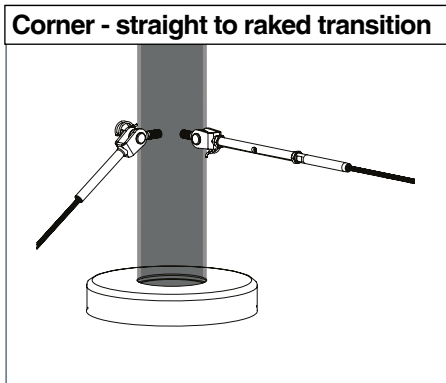
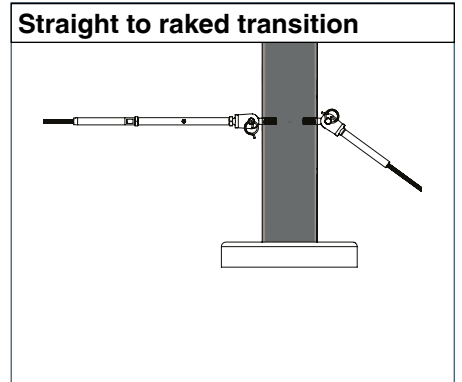



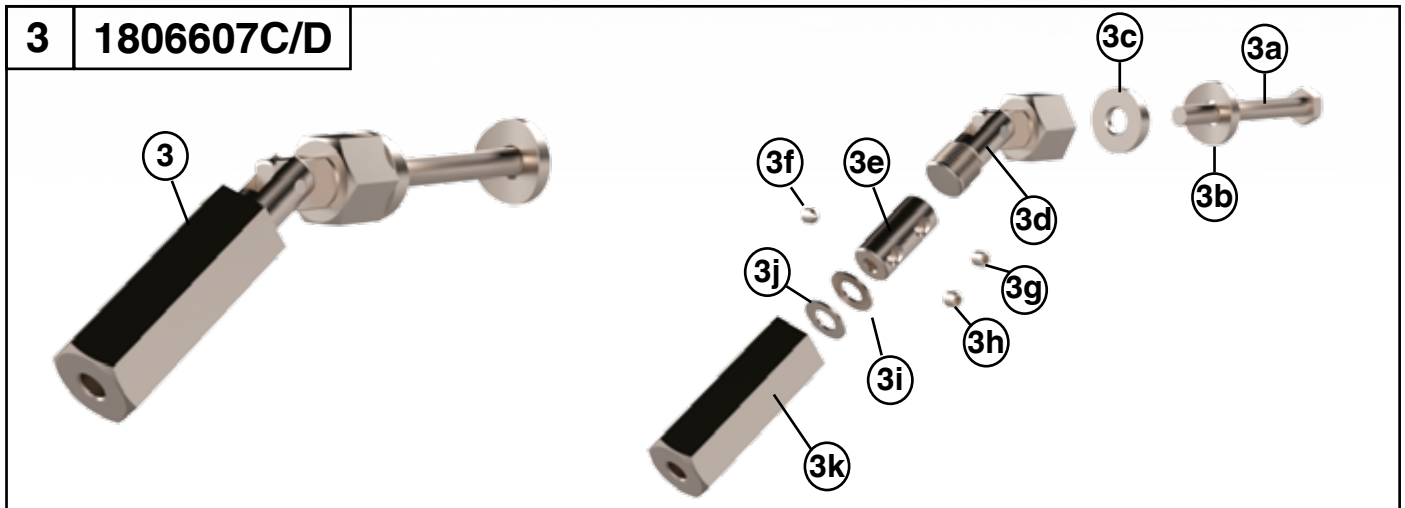
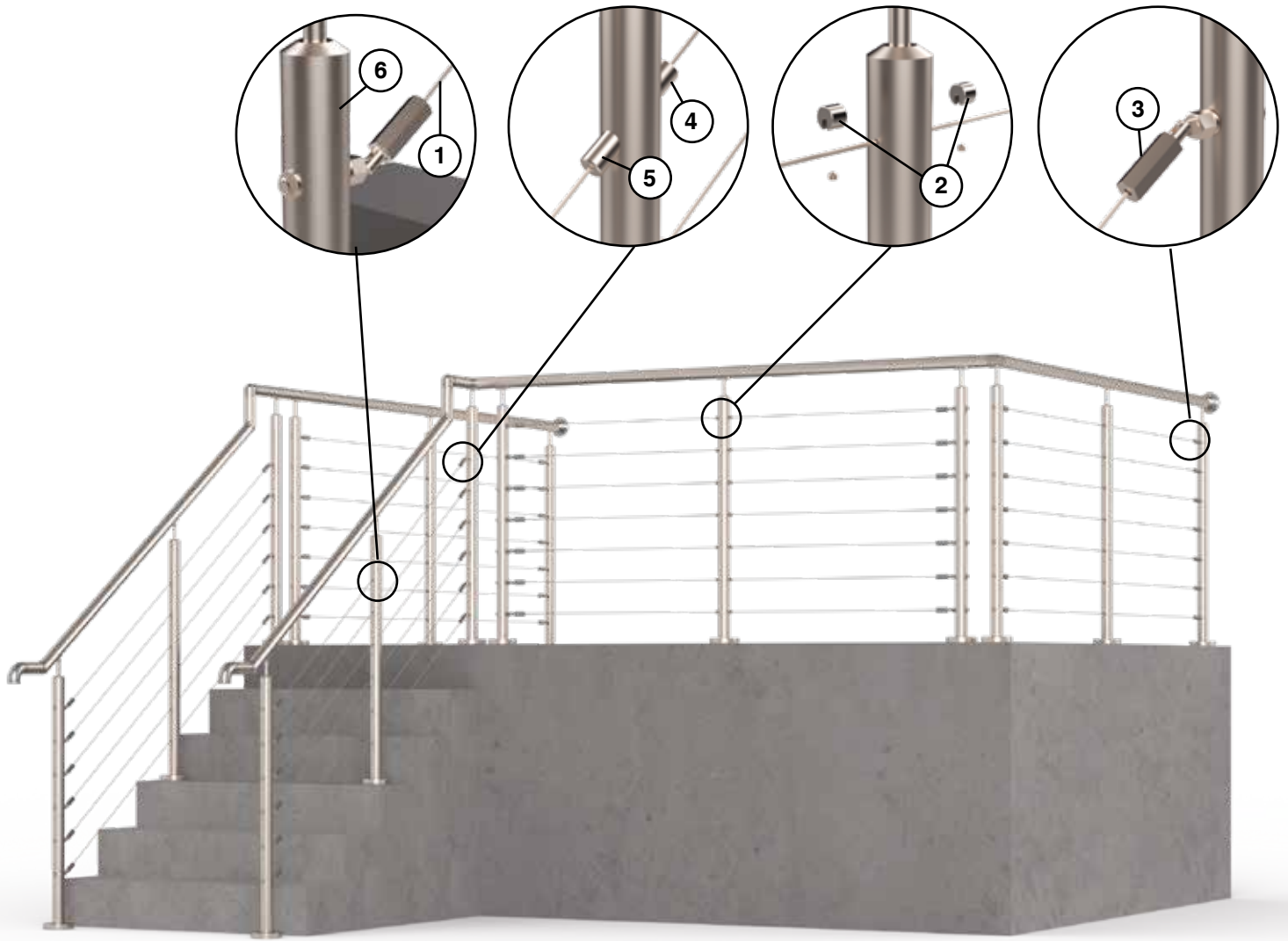





For finishing up to a wall, see page 27.



System 2 Components

ID	Description	Size	To Suit Wire Ø mm	Code
1	Wire Rope	10m	3	180660510
		50m	3	180660550
		100m	3	1806605100
2	Locking Collar	N/A	3	1806604
3	Articulated Wire Tensioner	Ø 42.4mm	3	1806607C
		Ø 48.3mm		1806607D
Optional				
4	Upward Angled Wire Rope Holder	Ø 42.4mm	3	1806622C
		Ø 48.3mm		1806622D
5	Downward Angled Wire Rope Holder	Ø 42.4mm	3	1806621C
		Ø 48.3mm		1806621D
6	Bespoke Posts (see page 28)	-	3	-

All components are stainless steel Grade 316.

Description	Symbol	Information
Drill		To pre-drill and tap posts to suit components
Saw		For cutting posts when building your own posts for straights or rakes
Crimping Tool		Use either Crimping Tool (code: 1899001102) or Hydraulic Crimping Tool (code: 189900103)
Wire Cutting Tool		To trim wire use code: 080569
Instant Adhesive		Use (code: 1899007454) as an instant adhesive gel for uniform stress distribution. Supplied with plunger for accurate application
Allen Key		To fix grub screws into locking collar (code: 189900606)
Spanner		To tighten nuts in wire rope components
Screwdriver		To tighten and create tension in the wire

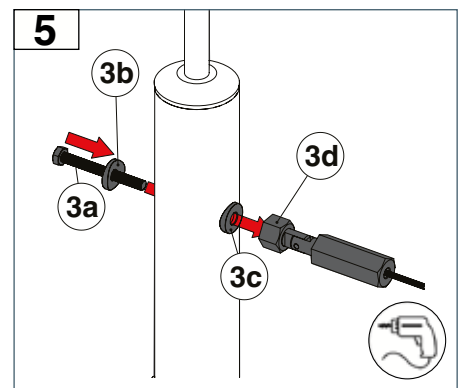
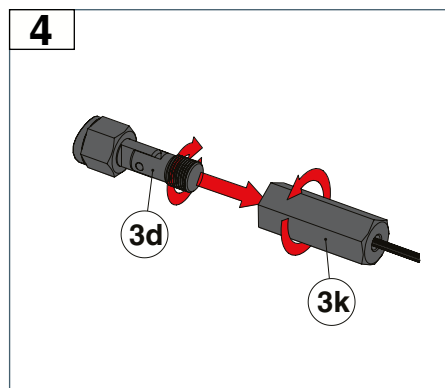
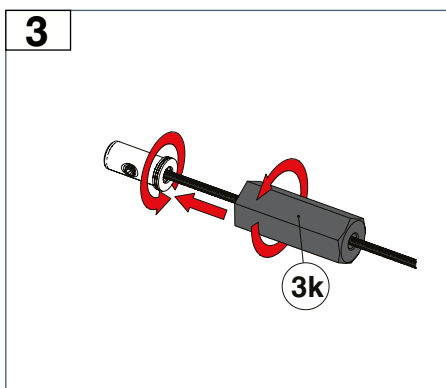
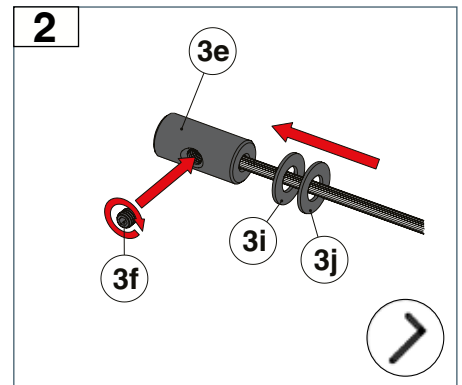
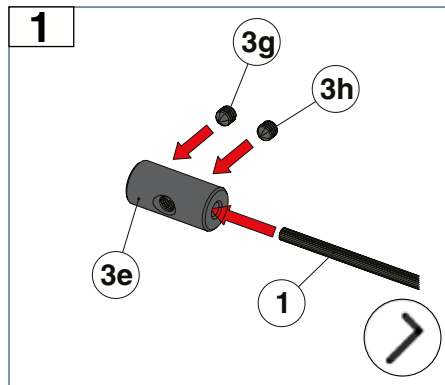
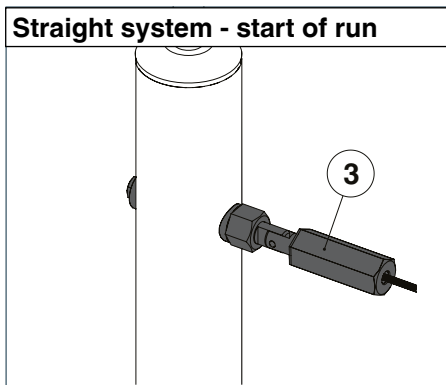

Drill and tap Ø 6mm hole into post.

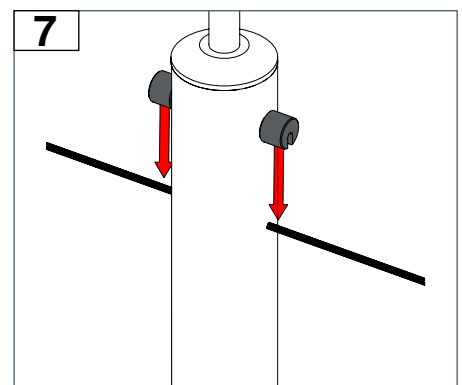
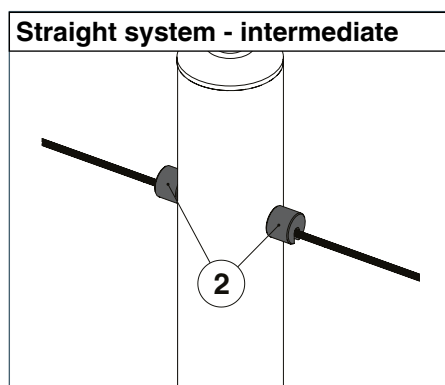
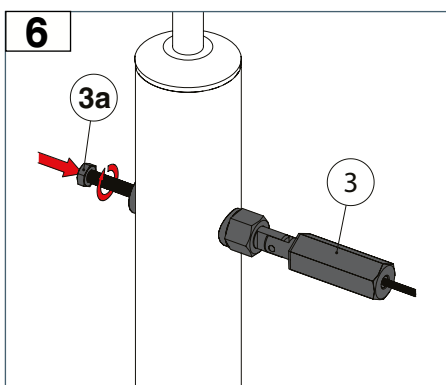

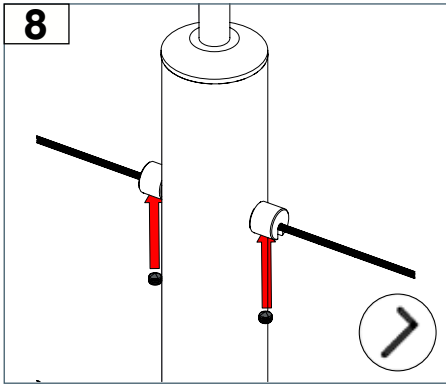

8
Loosely fix the locking collars between the intermediate posts and tighten at end

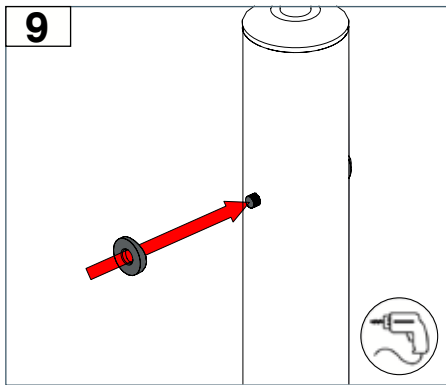
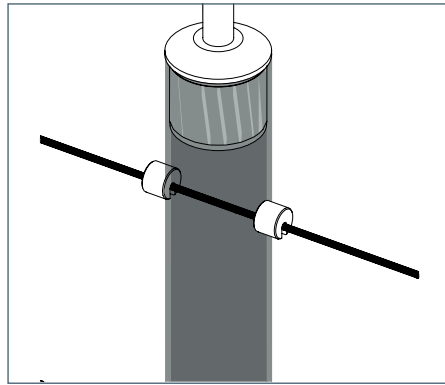

9
Drill and tap Ø 6mm hole into post.

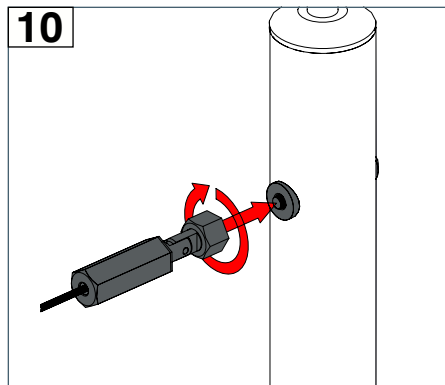

10
Fix end post component and tighten locking collar from intermediate posts to create tension. If tension is not correct, use release tool, cut wire and redo.

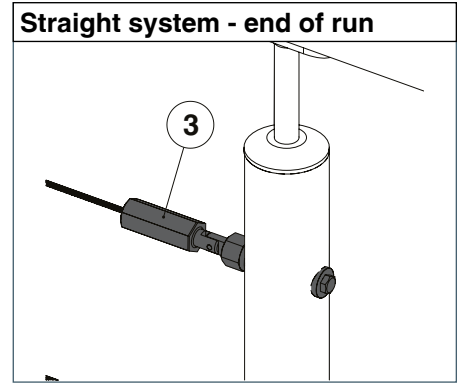

Straight system - end of run

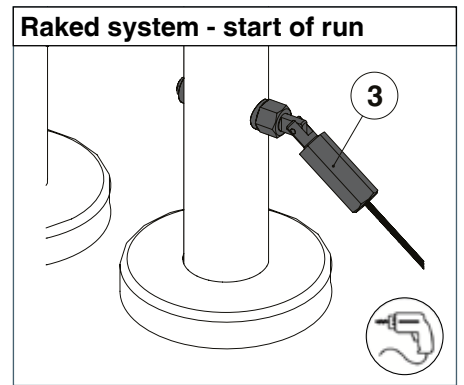

Raked system - start of run

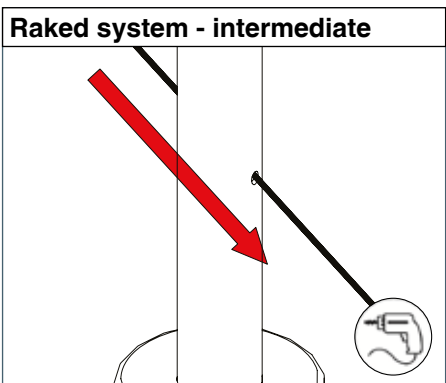

Raked system - intermediate
Feed wire loosely fix between the intermediate posts and tighten at end of run.

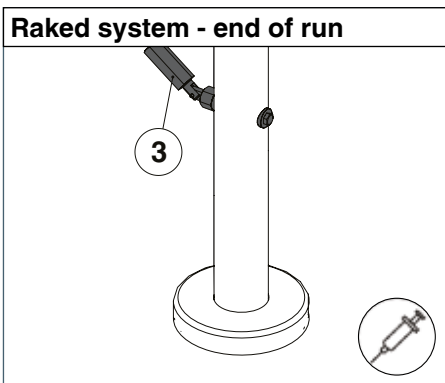

Raked system - end of run
Once wires have been tightened you can glue to fix. If tension is not correct, use release tool, cut wire and redo.

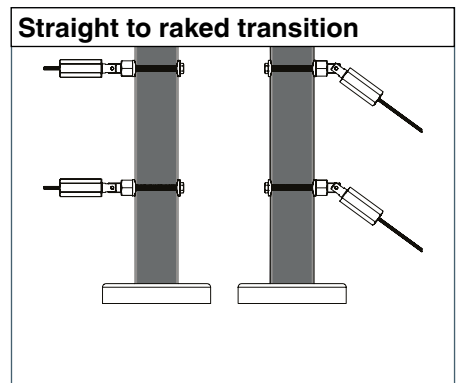

Straight to raked transition

Corner - straight to raked transition

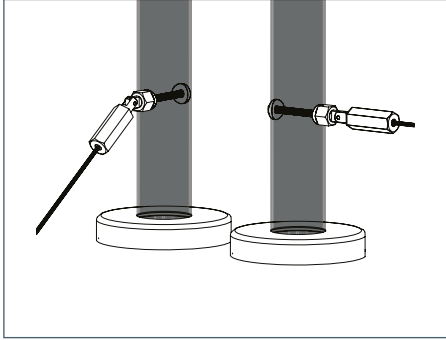

90 degree corner

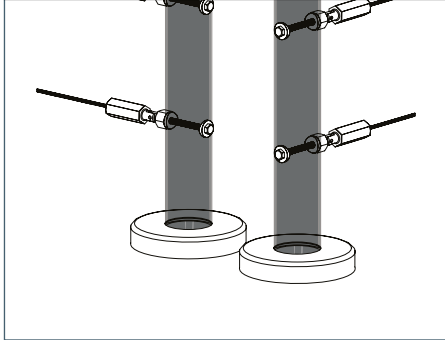

Finishing on end post

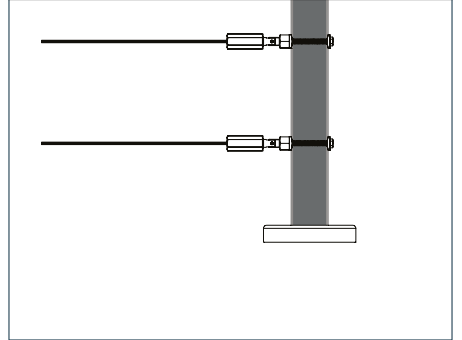



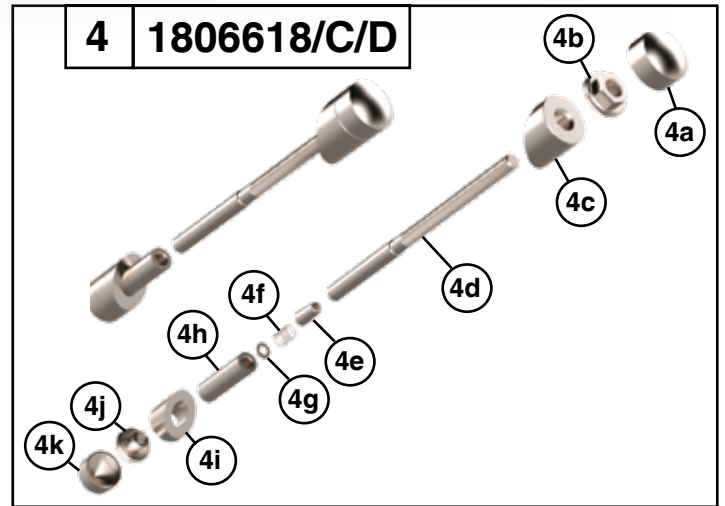
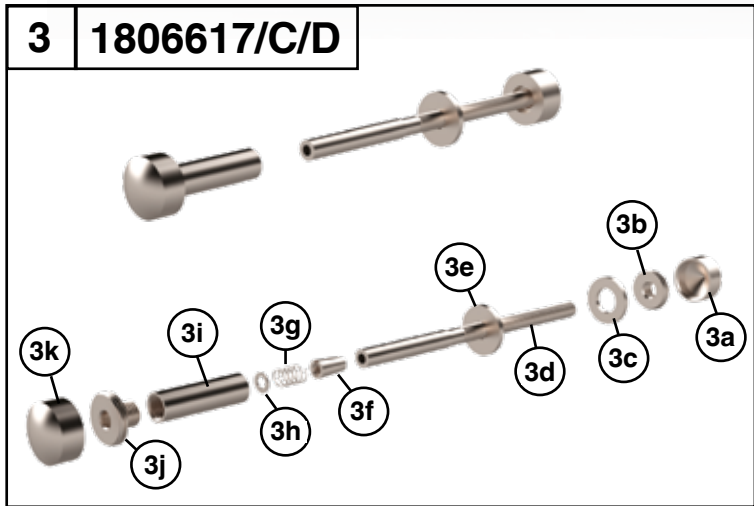
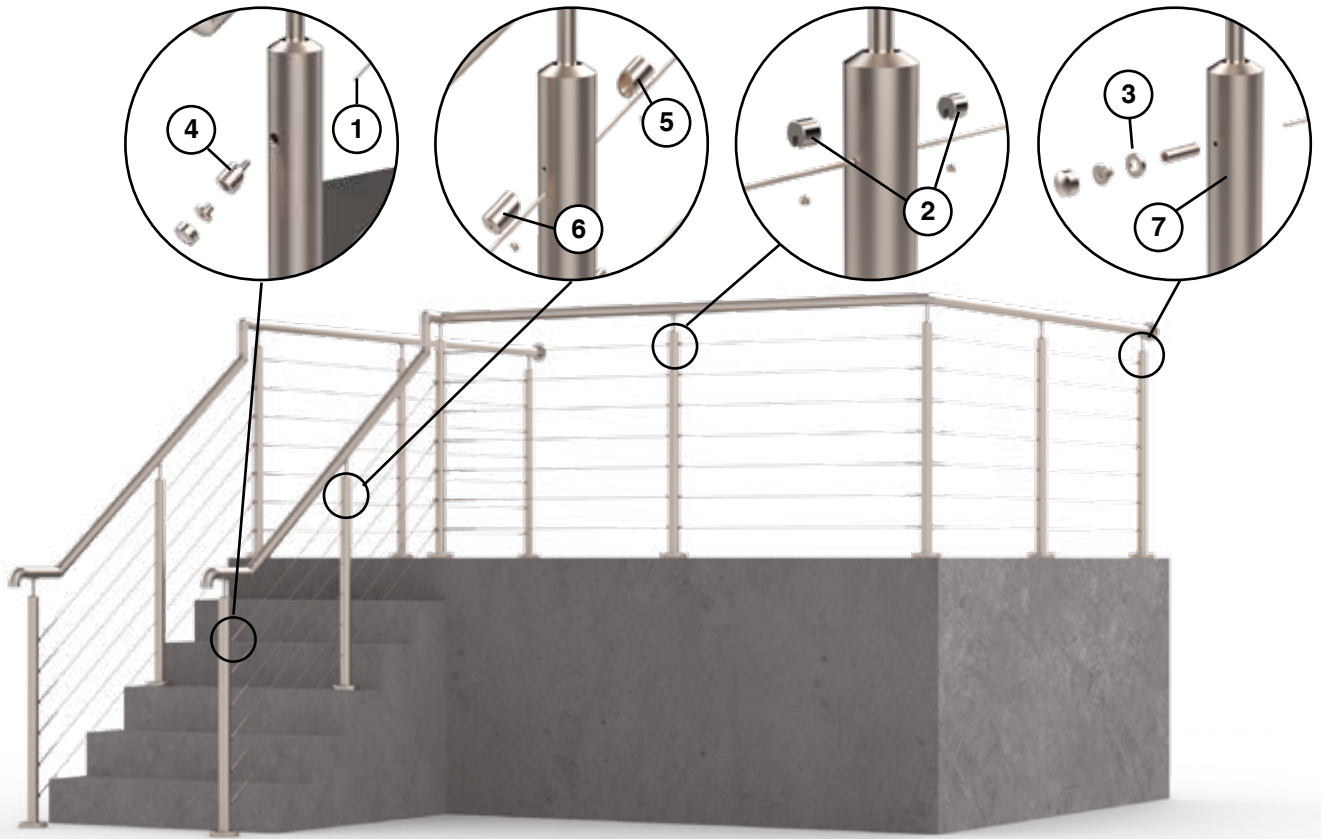



For finishing up to a wall, see page 27.



System 4 Components

ID	Description	Size	To Suit Wire Ø mm	Code
1	Wire Rope	10m	3	180660510
		50m	3	180660550
		100m	3	1806605100
2	Locking Collar	N/A	3	1806604
System 3 for Flat Runs				
3	Cable Tensioner	Flat	3	1806335C
		Ø 42.4mm		1806335D
		Ø 48.3mm		1806335C
System 3 for Stairs and Slopes				
4	Cable Tensioner	Flat	3	1806618
		Ø 42.4mm		1806618C
		Ø 48.3mm		1806618D
5	Upward Angled Wire Rope Holder	Flat	3	1806622
		Ø 42.4mm		1806622C
		Ø 48.3mm		1806622D
6	Downward Angled Wire Rope Holder	Flat	3	1806621
		Ø 42.4mm		1806621C
		Ø 48.3mm		1806621D
7	Bespoke Posts (see page 28)	-	3	-

All components are stainless steel Grade 316.

Description	Symbol	Information
Drill		To pre-drill and tap posts to suit components
Saw		For cutting posts when building your own posts for straights or rakes
Crimping Tool		Use either Crimping Tool (code: 1899001102) or Hydraulic Crimping Tool (code: 189900103)
Wire Cutting Tool		To trim wire use code: 080569
Instant Adhesive		Use (code: 1899007454) as an instant adhesive gel for uniform stress distribution. Supplied with plunger for accurate application
Allen Key		To fix grub screws into locking collar (code: 189900606)
Spanner		To tighten nuts in wire rope components

NB: For the swaged nozzles you can either crimp the nozzles OR fill the nozzles with glue and stick the wire into the nozzle.

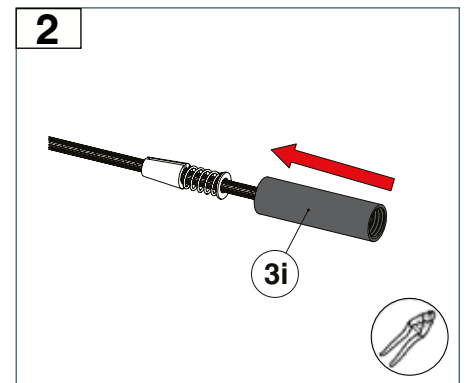
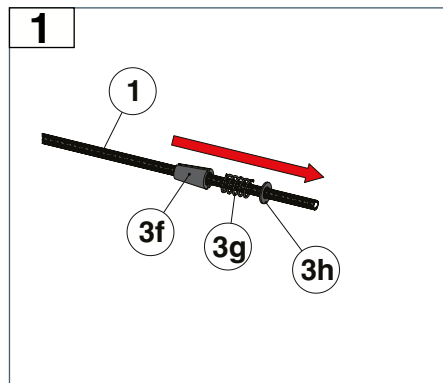
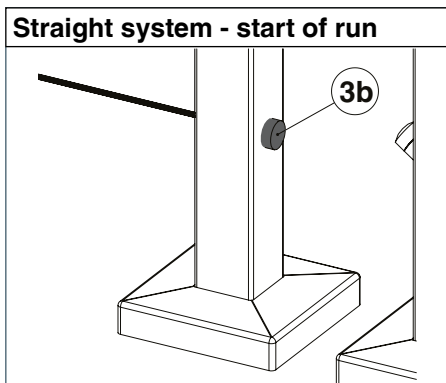

Measure on a flat surface and cut the wire.

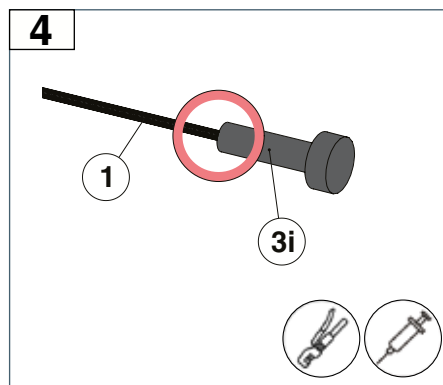
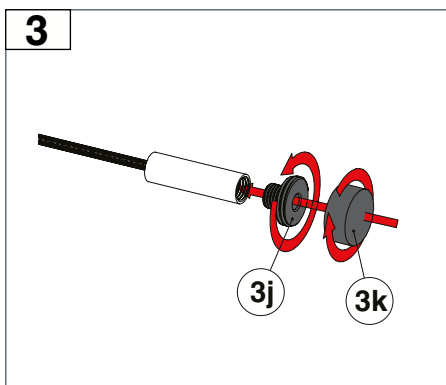

Crimp or glue 1 into 3i.

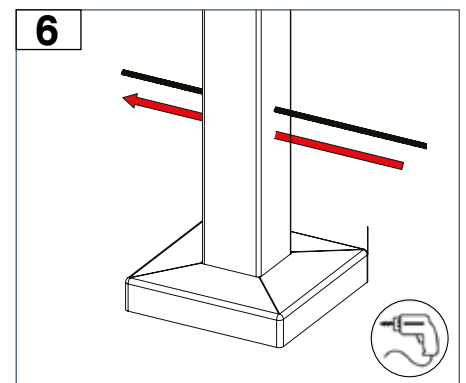
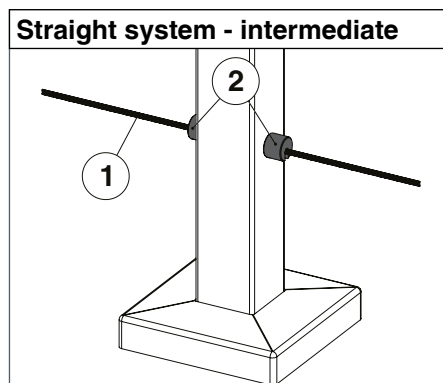
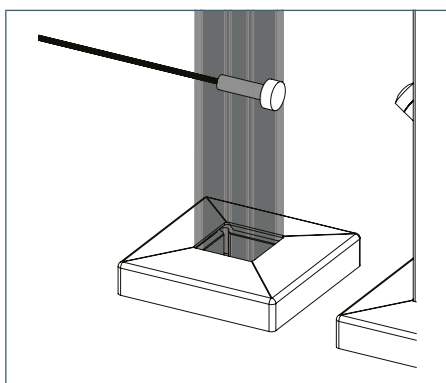
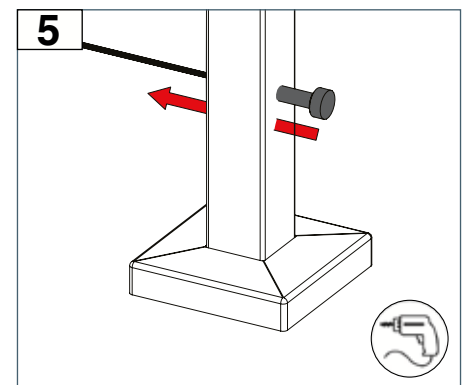

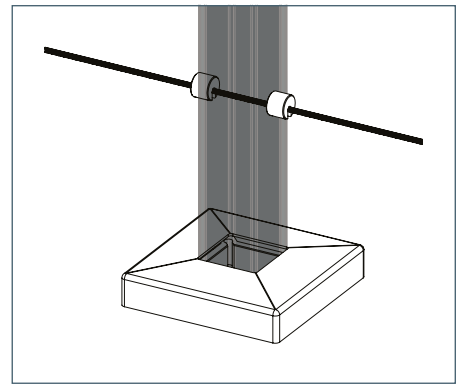
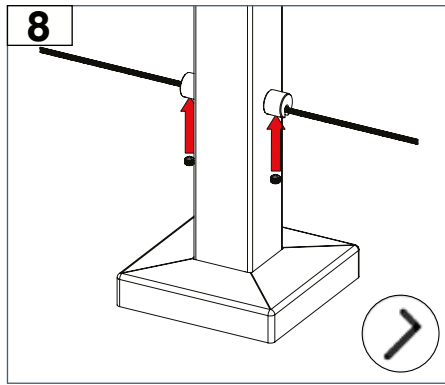
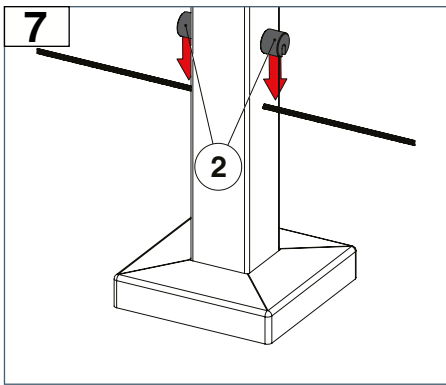

Loosely fix the locking collars between the intermediate posts and tighten at end.

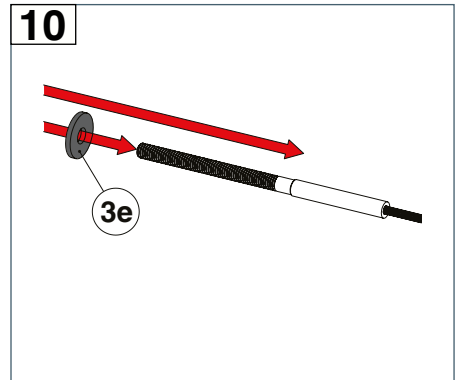
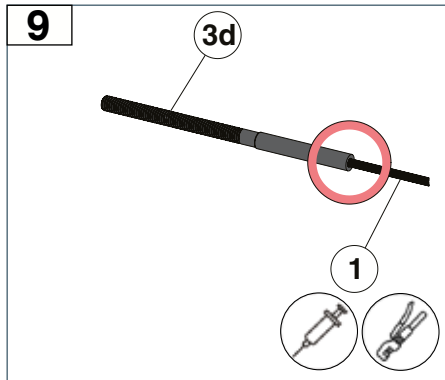
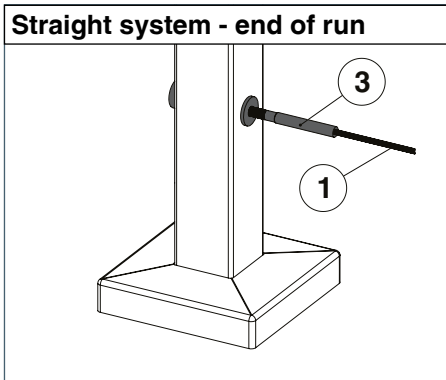

Crimp or glue 1 into 3d.

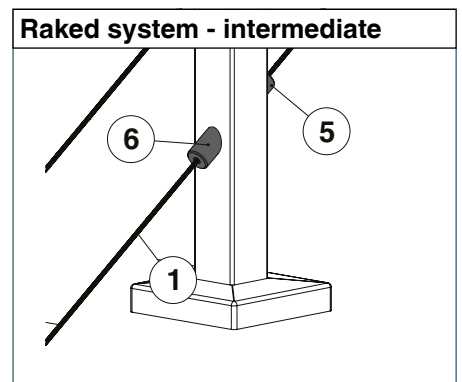
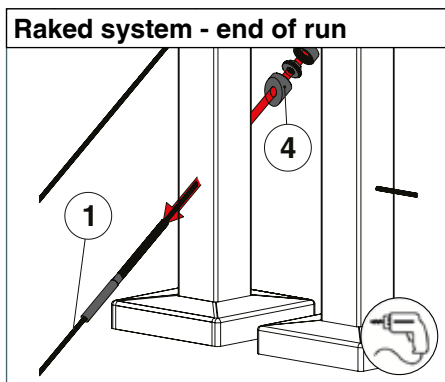
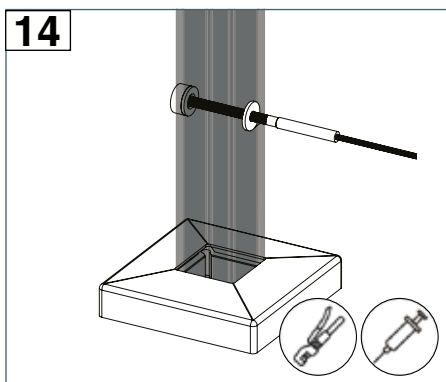
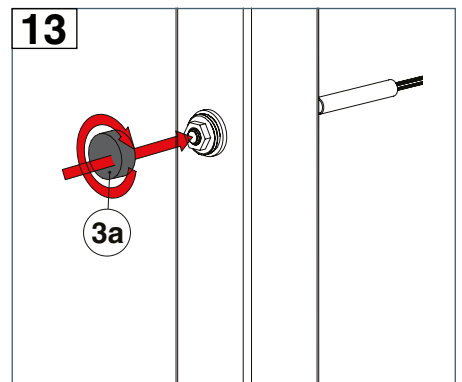
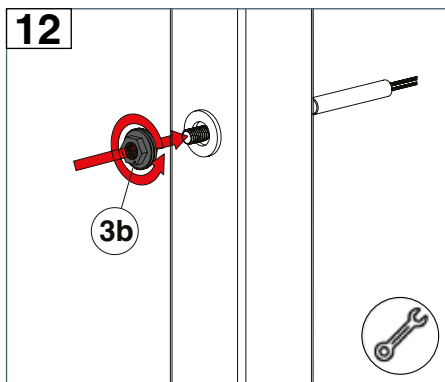
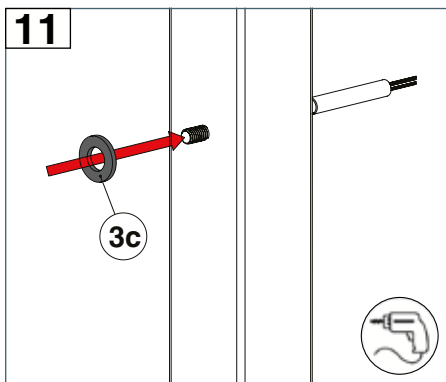

Once wires have been tightened you can crimp or glue to fix.

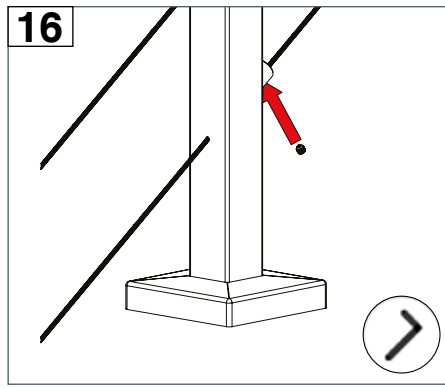
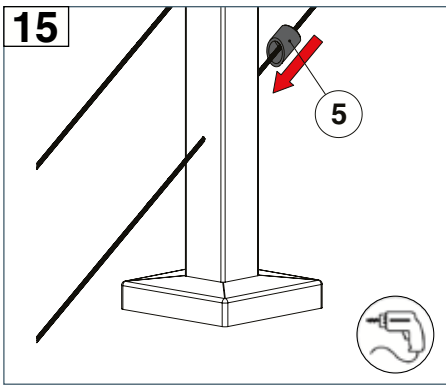

Loosely fix the locking collars between the intermediate posts and tighten at end.

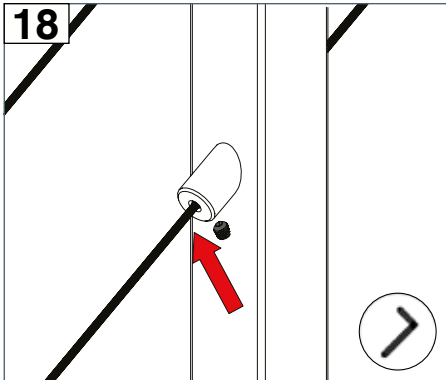
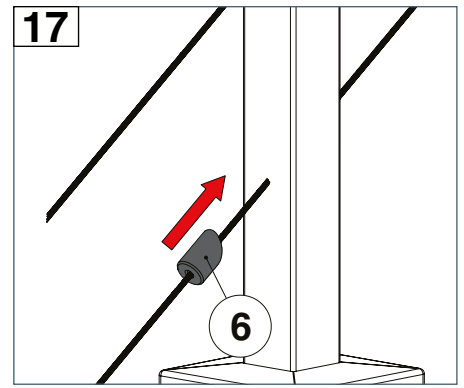

Loosely fix between the intermediate posts and tighten at end.

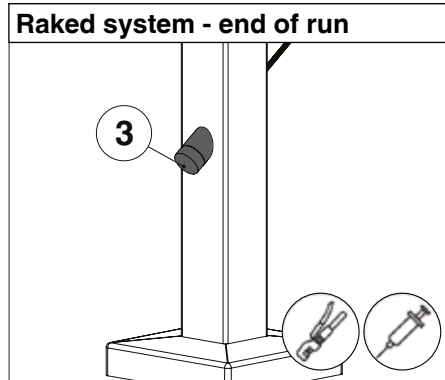

Once wires have been tightened you can crimp or glue to fix.

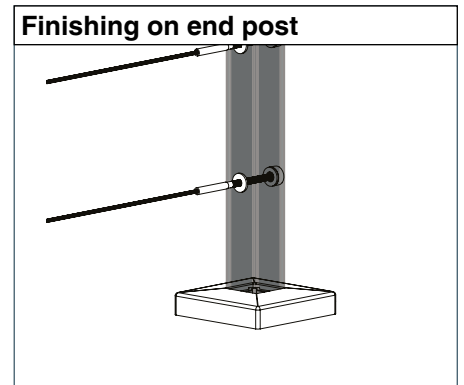
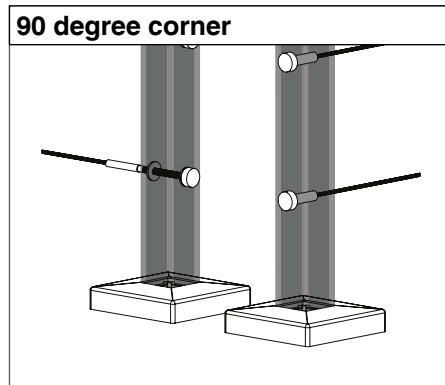
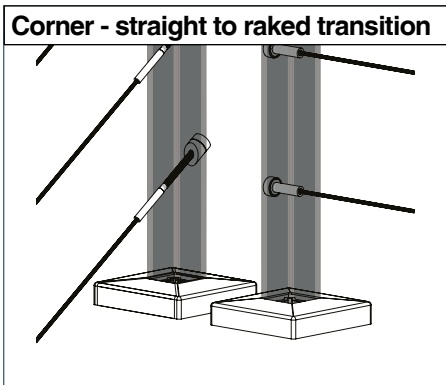
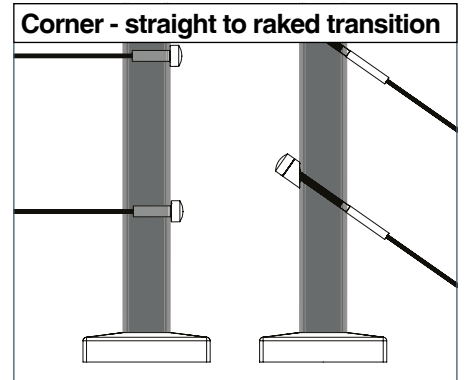



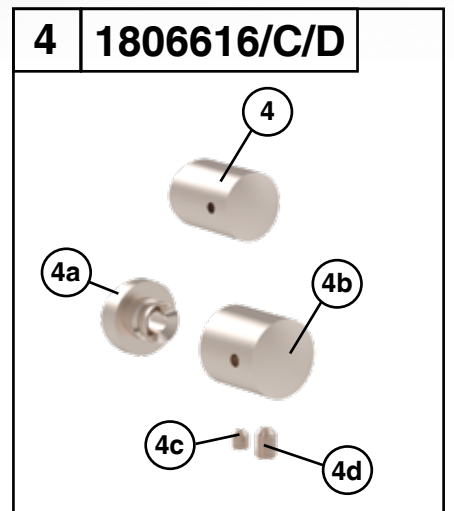
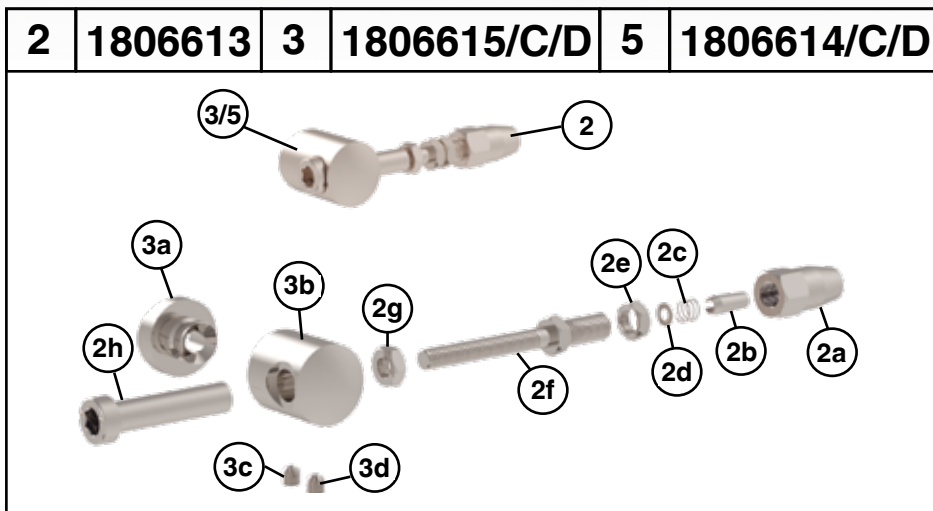
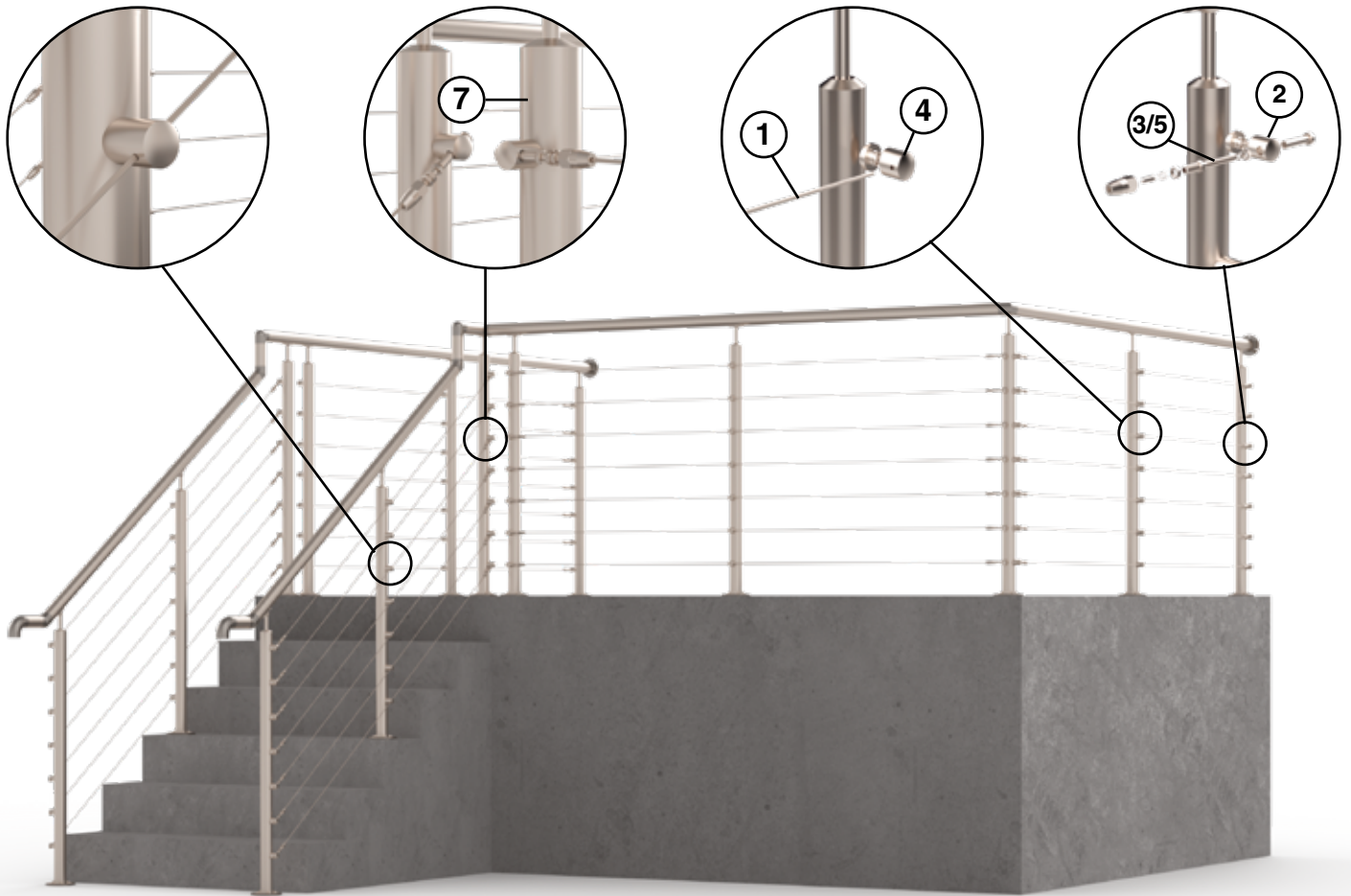



For finishing up to a wall, see page 27.



System 5 Components

ID	Description	Size	To Suit Wire Ø mm	Code
1	Wire Rope	10m	3	180660510
		50m	3	180660550
		100m	3	1806605100
2	Cable Tensioner (Through Fitting)	N/A	3	1806613
3	Left Hand Side Angled Wire Rope Holder	Flat	3	1806615
		Ø 42.4mm		1806615C
		Ø 48.3mm		1806615D
4	Middle Angled Wire Rope Holder	Flat	3	1806616
		Ø 42.4mm		1806616C
		Ø 48.3mm		1806616D
5	Right Hand Side Angled Wire Rope Holder	Flat	3	1806614
		Ø 42.4mm		1806614C
		Ø 48.3mm		1806614D
6	Socket Countersunk Head Screw	M6 x 20mm	-	189900603
7	Bespoke Posts (see page 28)	-	3	-

All components are stainless steel Grade 316.

Description	Symbol	Information
Drill		To pre-drill and tap posts to suit components
Saw		For cutting posts when building your own posts for straights or rakes
Crimping Tool		Use either Crimping Tool (code: 1899001102) or Hydraulic Crimping Tool (code: 189900103)
Wire Cutting Tool		To trim wire use code: 080569
Instant Adhesive		Use (code: 1899007454) as an instant adhesive gel for uniform stress distribution. Supplied with plunger for accurate application
Allen Key		To fix grub screws into locking collar (code: 189900606)
Spanner		To tighten nuts in wire rope components

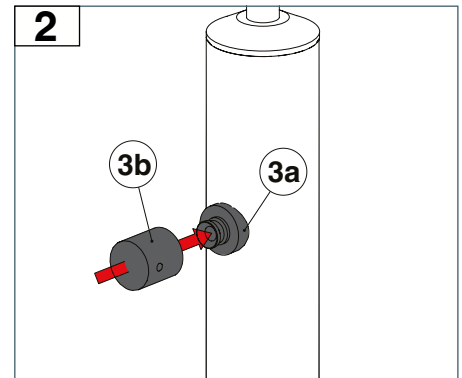
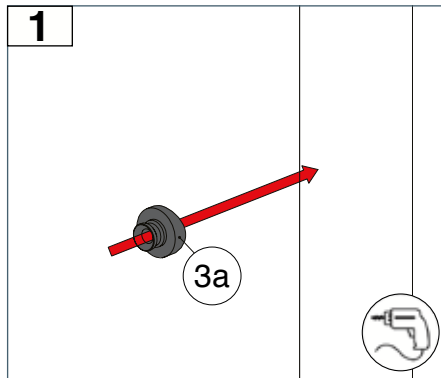
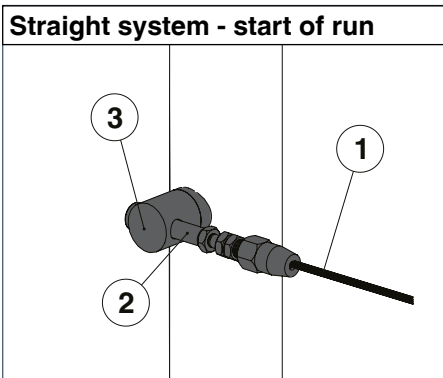

Drill and tap Ø 6mm hole into post.

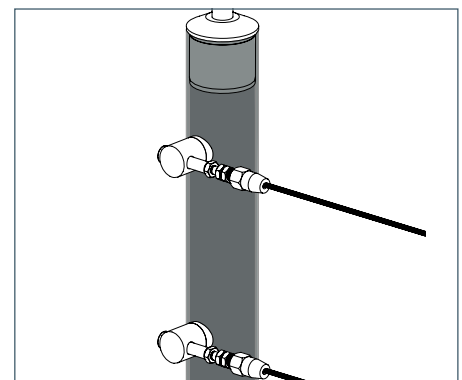
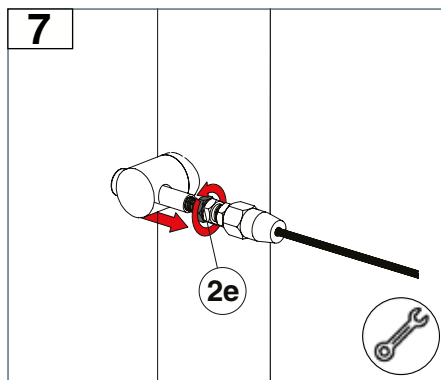
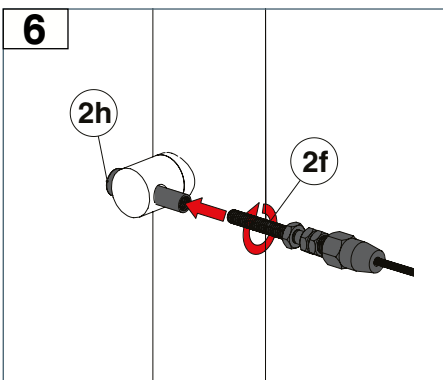
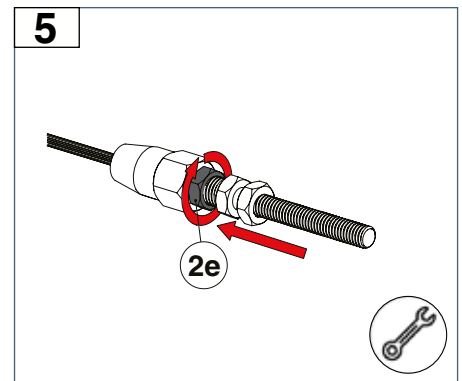
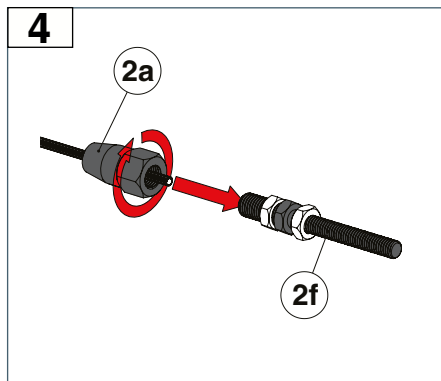
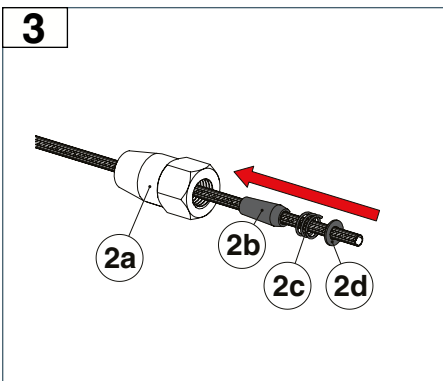

Straight system - intermediate

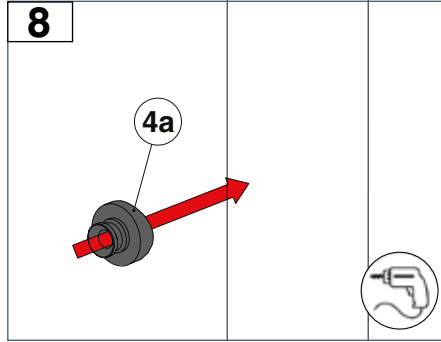
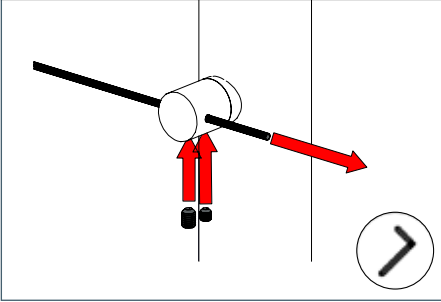

Drill and tap Ø 6mm hole into post.

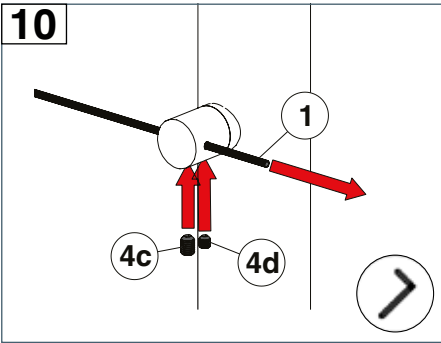
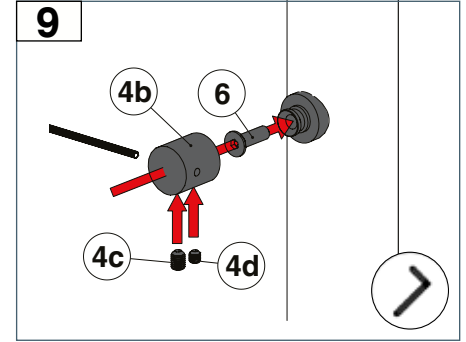

Loosely fix the grub screws between the intermediate posts and tighten at end.

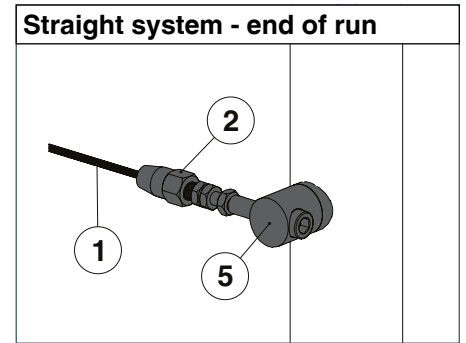
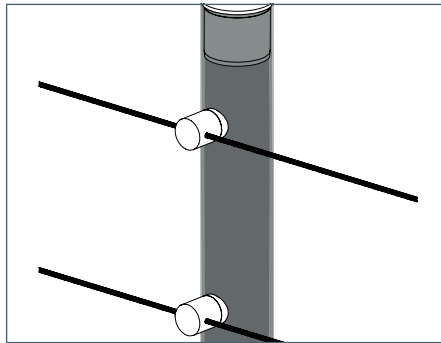

Straight system - end of run

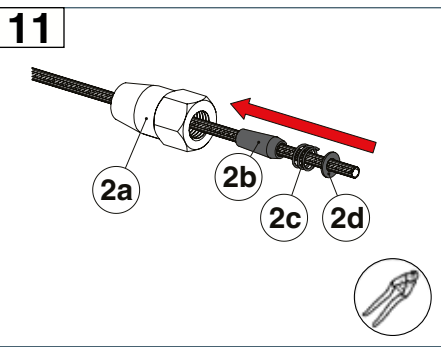

Measure with components up to post and cut the wire to rough estimate.

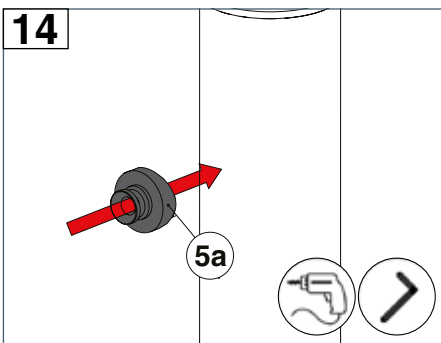
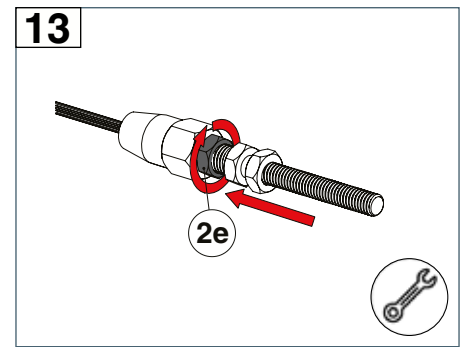
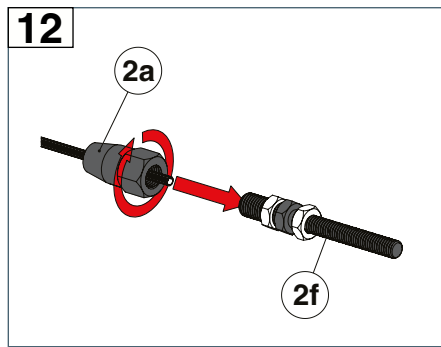

Drill and tap Ø 6mm hole into post. Fix with 6.

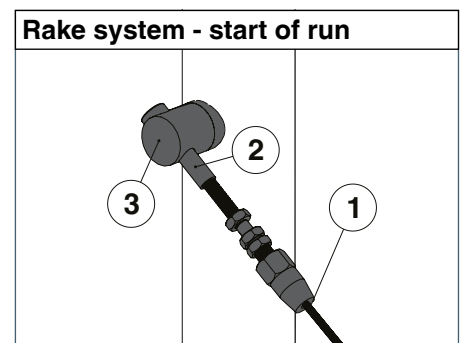
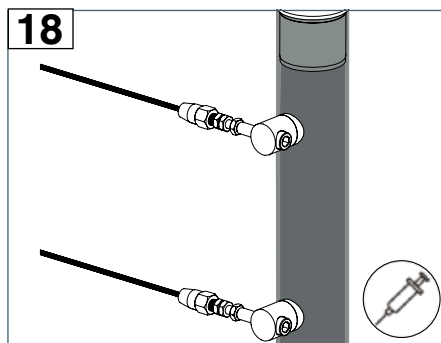
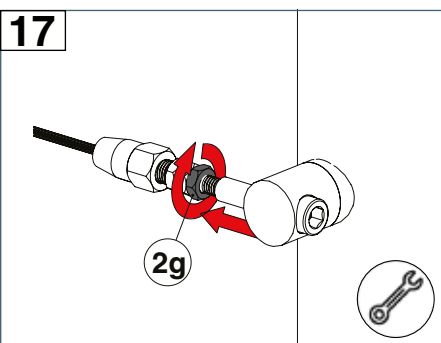
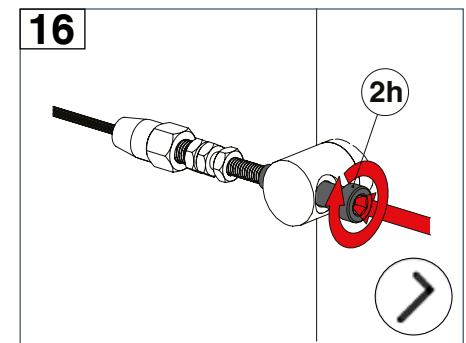
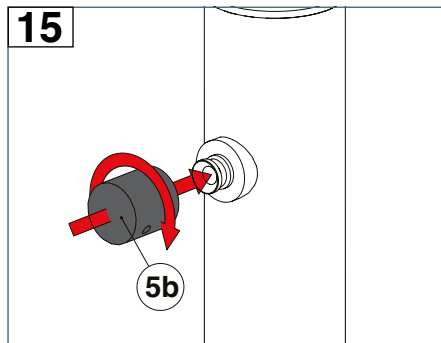

Rake system - start of run

Once wires have been tightened use glue to fix. If tension is not correct, use release tool, cut wire and redo.

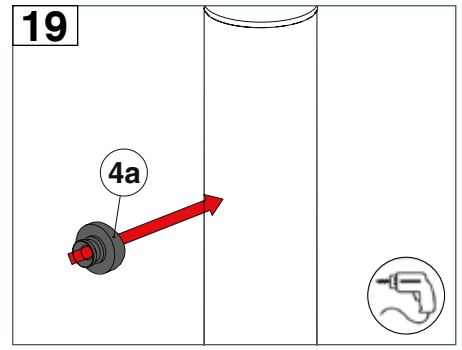
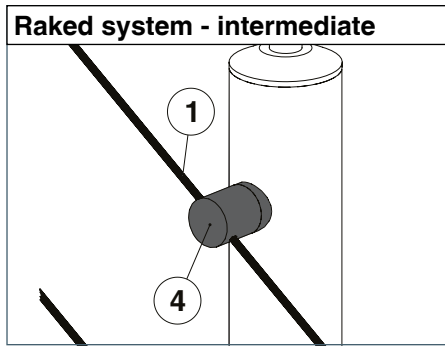
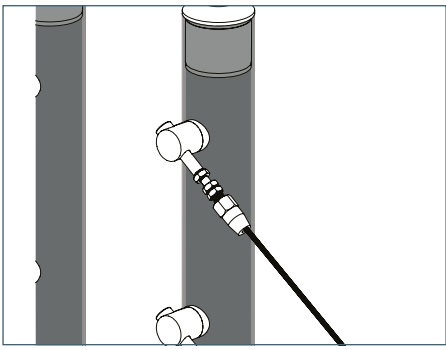

Drill and tap Ø 6mm hole into post.

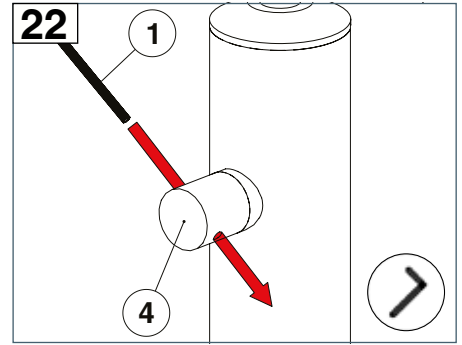
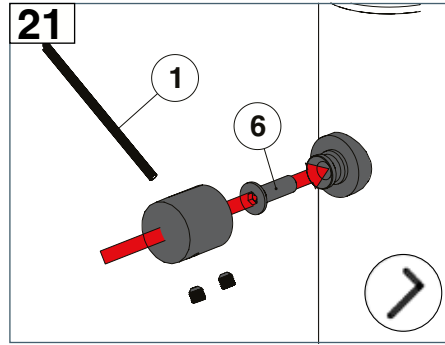
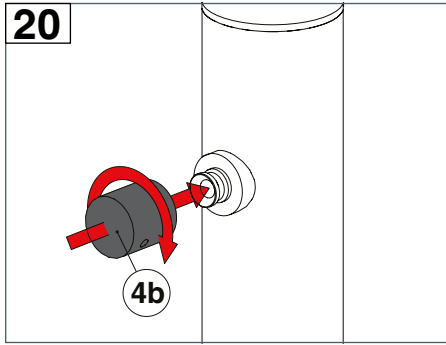

Loosely fix the grub screws between the intermediate posts and tighten at end.

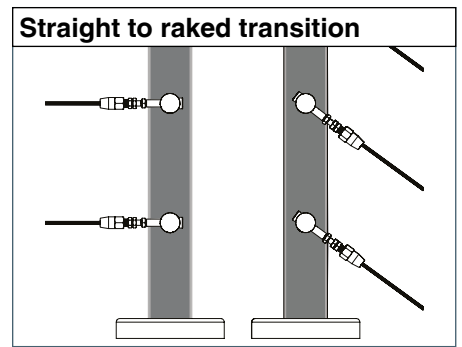
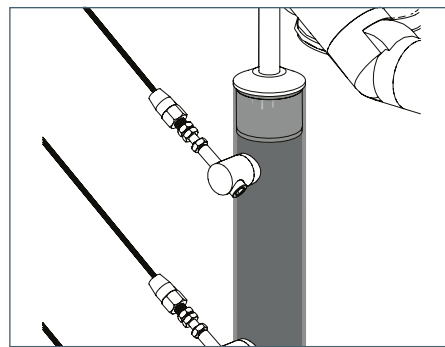
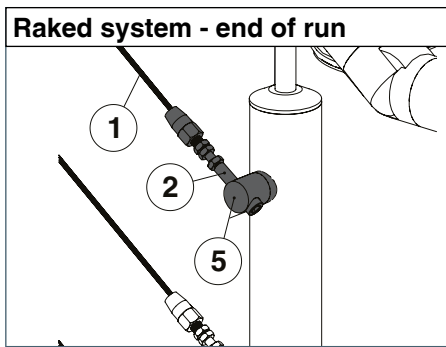

If tension is not correct after wires have been tightened. Use release tool, cut wire and redo.

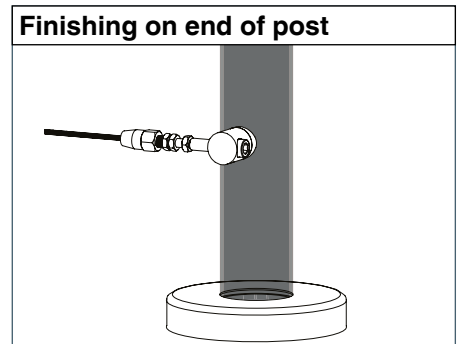
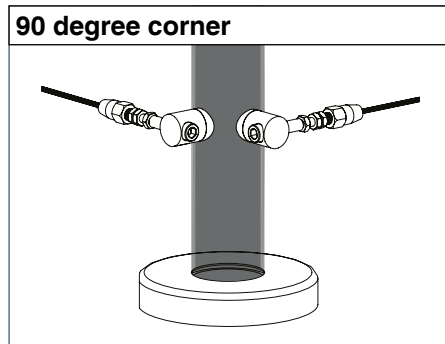
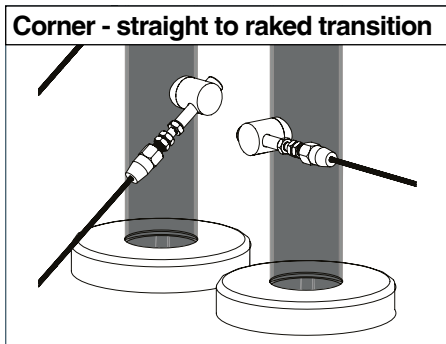



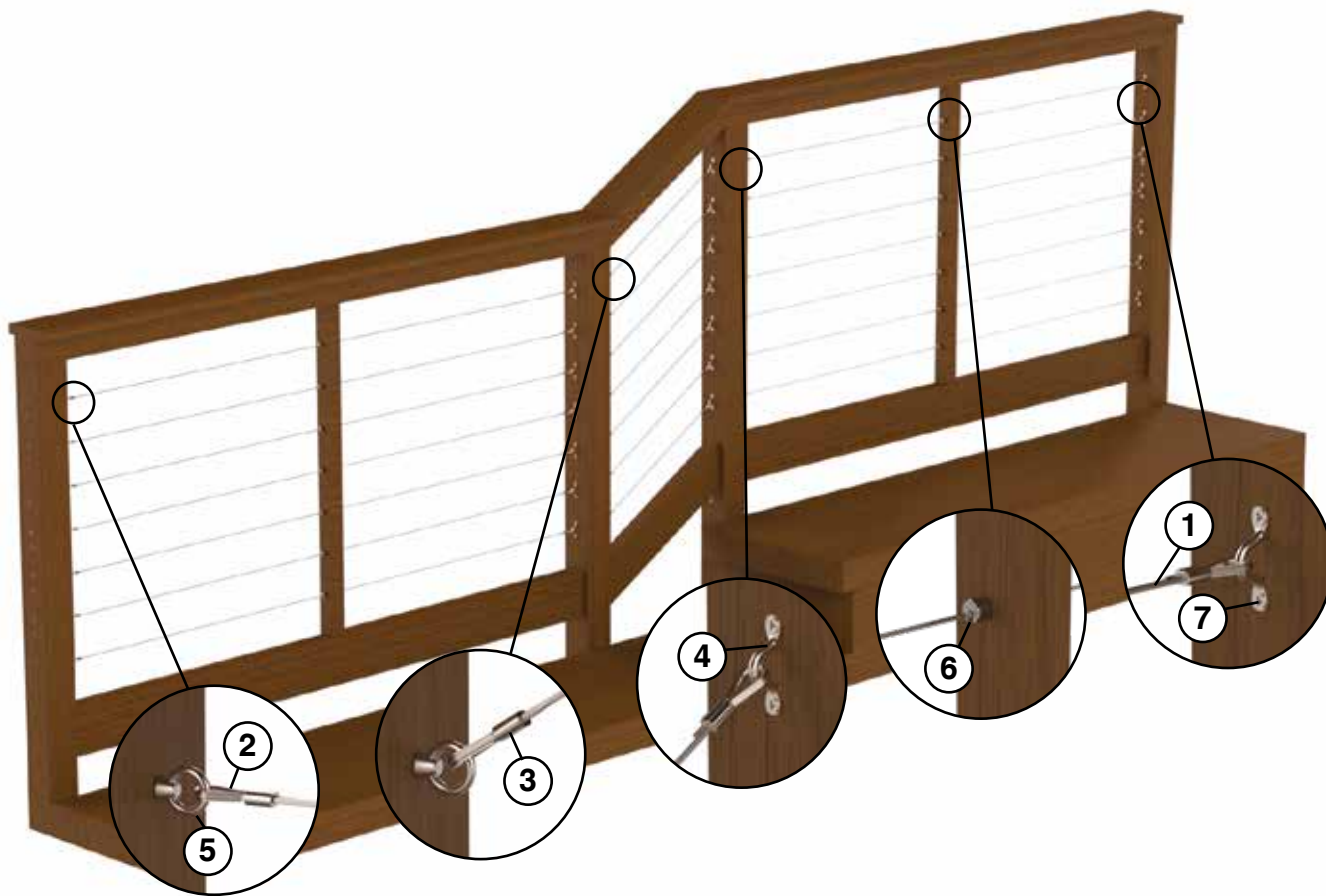



If tension is not correct after wires have been tightened. Use release tool, cut wire and redo. For finishing on a wall, see page 27.



System 6 Components

ID	Description	Size	To Suit Wire Ø mm	Code
1	Wire Rope	10m	3	180660510
		50m	3	180660550
		100m	3	1806605100
2	Thimble	N/A	3	1806609
3	Ferrule	N/A	3	1806603
4	Pad Eye	N/A	3	1806608
5	Eyebolt Woodscrew Thread	N/A	3	1806606
6	Locking Collar	N/A	3	1806604
7	Self Tapping Screw Panhead - (Qty 200)	4.2 x 16mm	3	5004PS4216

Description	Symbol	Information
Drill		To pre-drill and tap posts to suit components
Saw		For cutting posts when building your own posts for straights or rakes
Crimping Tool		Use either Crimping Tool (code: 1899001102) or Hydraulic Crimping Tool (code: 189900103)
Wire Cutting Tool		To trim wire use code: 080569
Instant Adhesive		Use (code: 1899007454) as an instant adhesive gel for uniform stress distribution. Supplied with plunger for accurate application
Allen Key		To fix grub screws into locking collar (code: 189900606)
Spanner		To tighten nuts in wire rope components

NB: For the swaged nozzles you can either crimp the nozzles OR fill the nozzles with glue and stick the wire into the nozzle.

Straight system - start of run

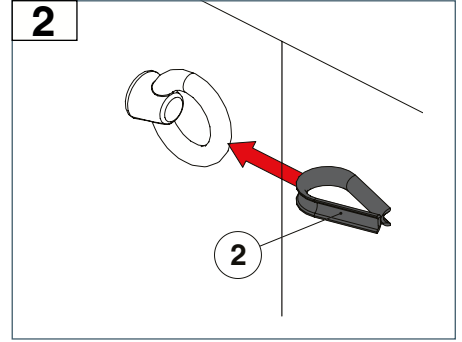
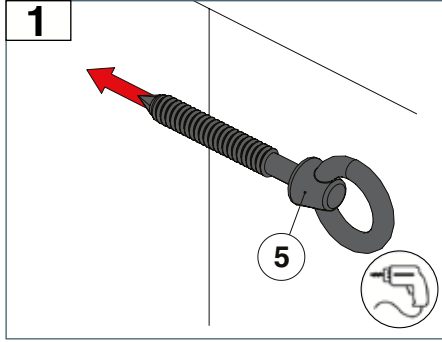
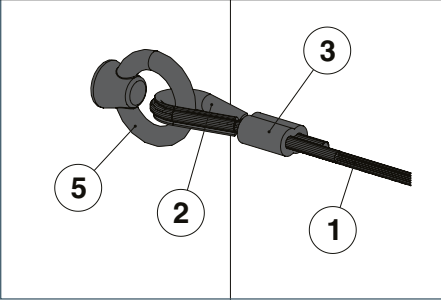

Tap \varnothing 6mm holes into posts for 5.

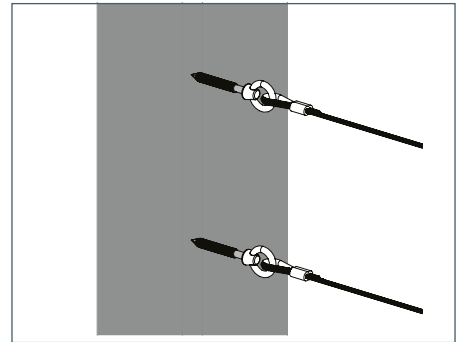
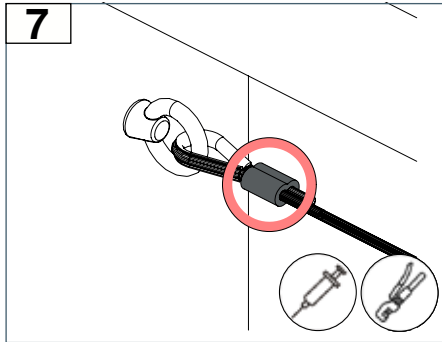
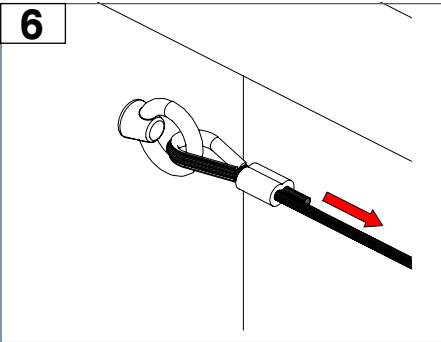
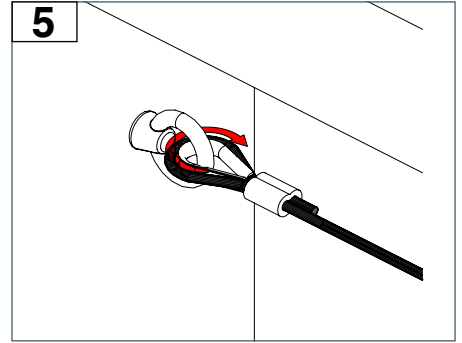
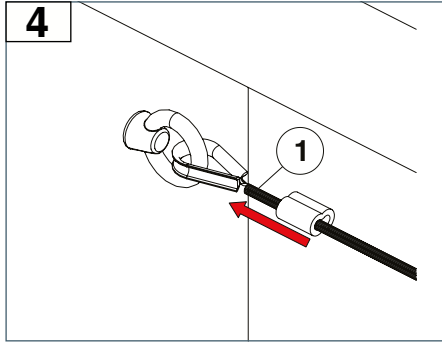
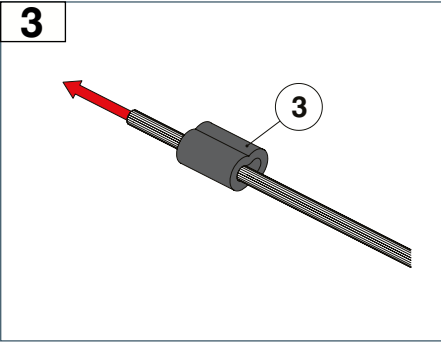

Crimp or glue into place.

Intermediate post

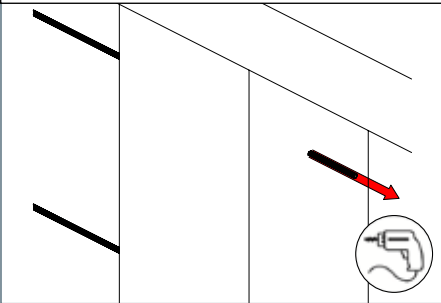

Drill \varnothing 6mm hole into post.

Straight system - end of run

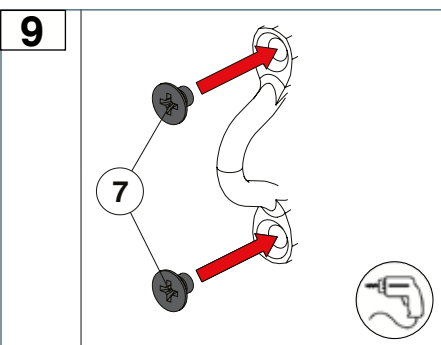
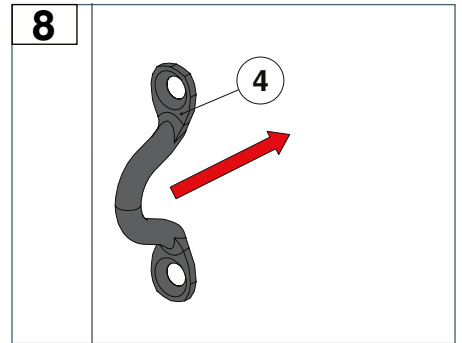
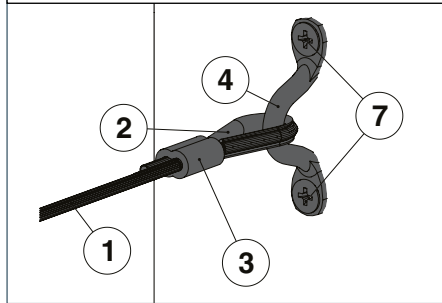

Drill \varnothing 4mm hole into post. Drill 7 in 4 to fix to post.

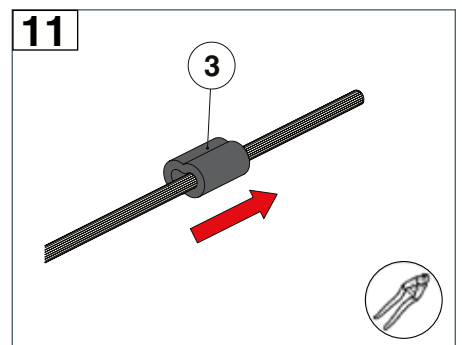
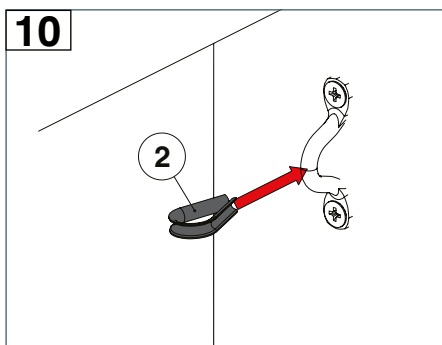

Cut the wire to correct length

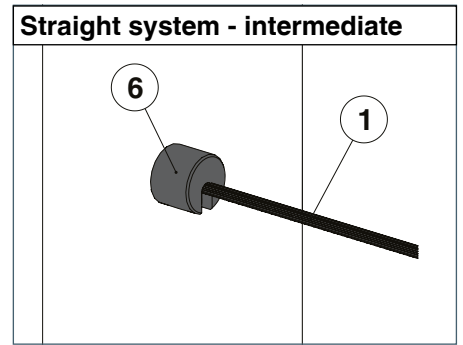
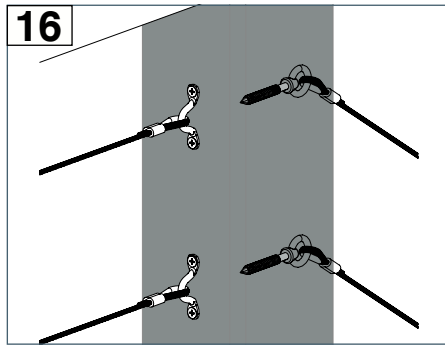
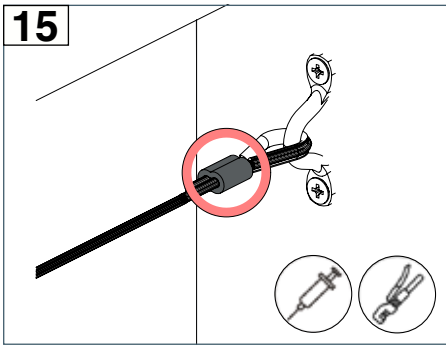
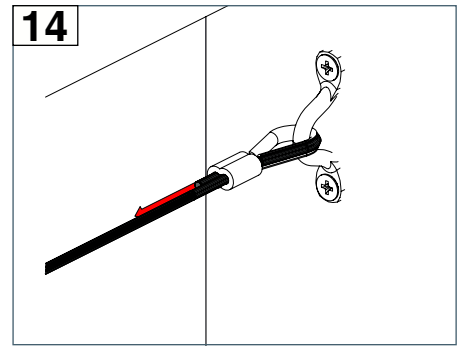
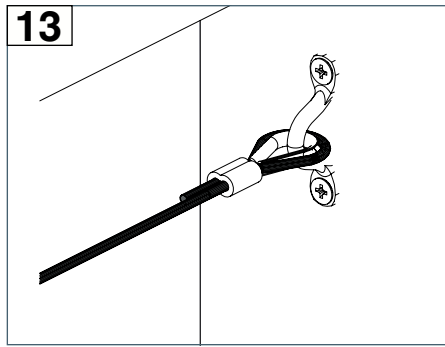
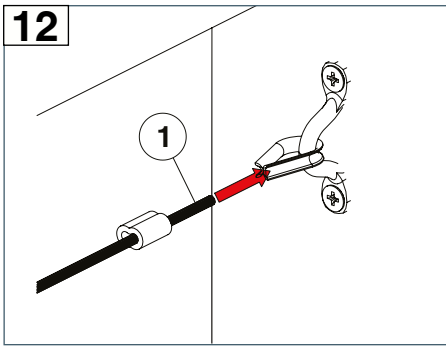

Crimp or glue into place.

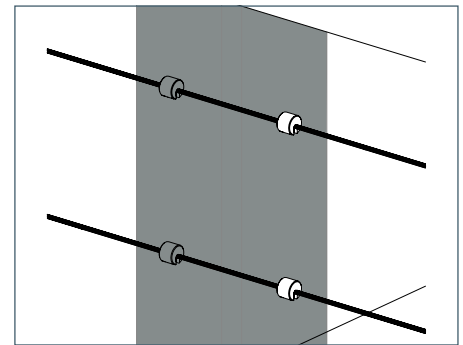
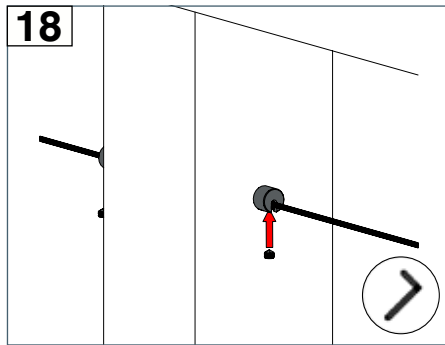
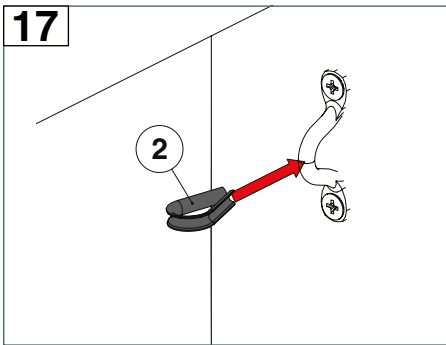

Once intermediate wires have been tightened and tensioned, tighten the grub screws on the intermediate post.

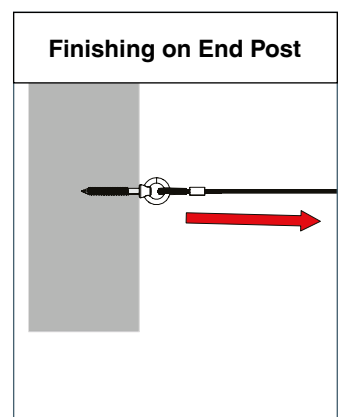
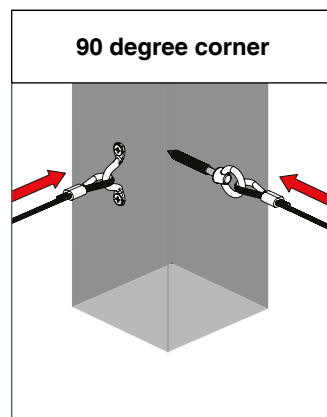
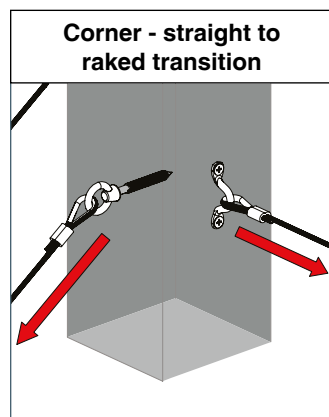
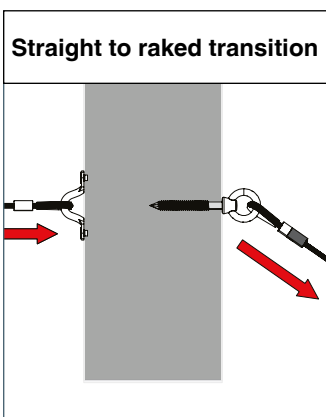
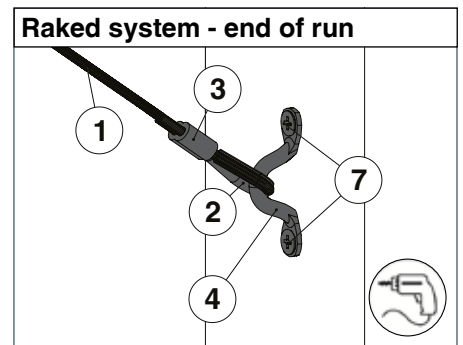
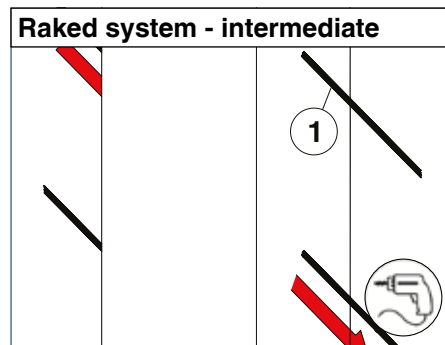
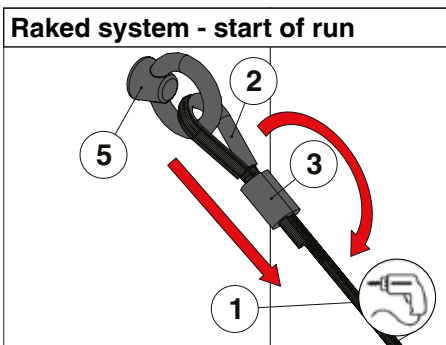

For finishing up to a wall, see page 27.

If you wish to finish at a wall and not a post, follow the instructions below to achieve this run.

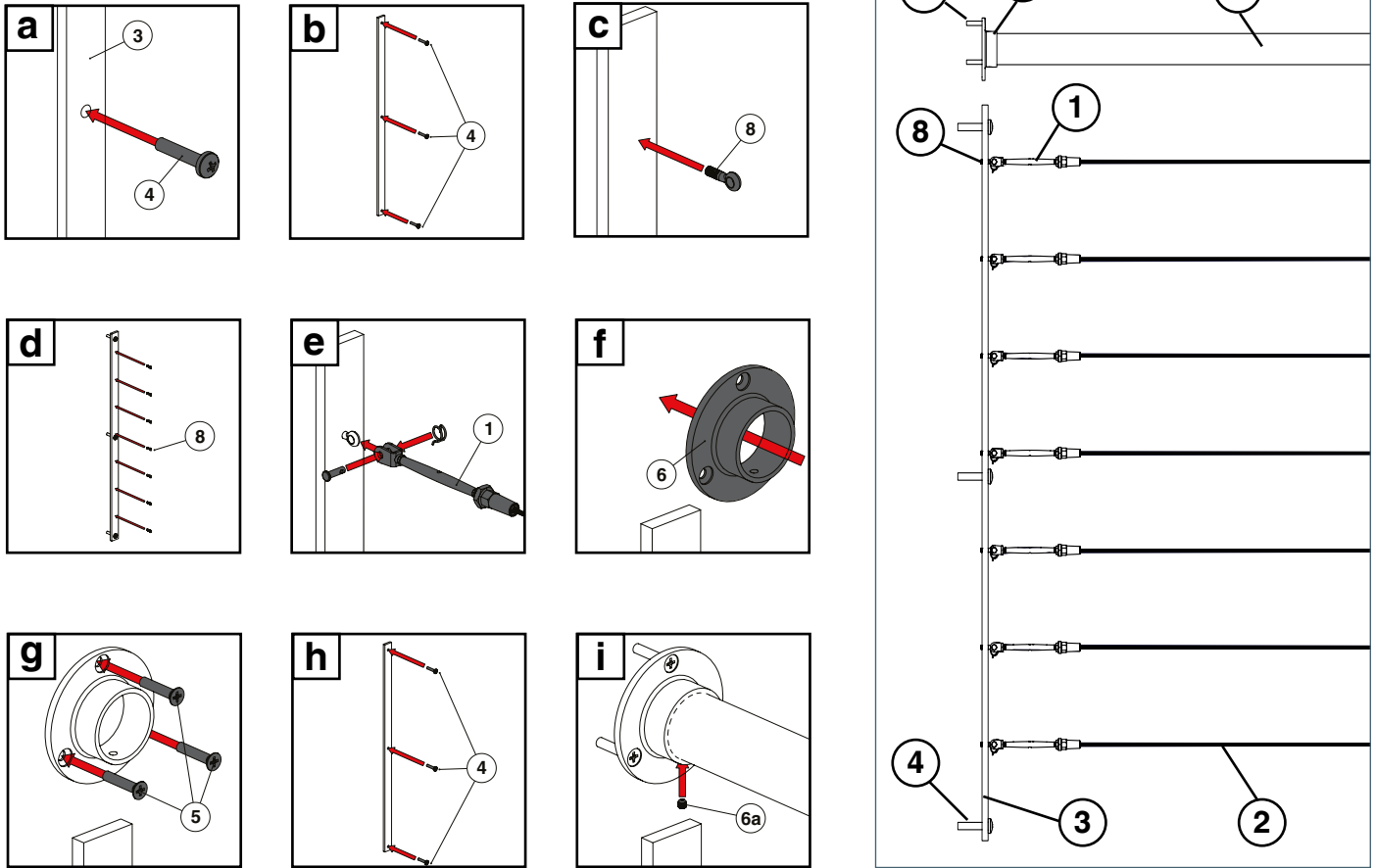

ID	Description	Product Code
1	Swaged / swageless component	1806601/1806602/1806611/1806612
2	Wire Rope	180660510/180660550/1806605100
3	40 x 10mm Flat Bar	300340103
4	M10 Anchor Bolt	189900649
5	6mm Countersunk Screws	N/A
6	External Fit Round Tube Flange	1806209C/ 1806209D
7	Stainless Steel Tube - Type 316	1806700C/1806700D
8	Eye bolt Connector	1806603

Our post fitting adaptor ring is perfect for bespoke end posts to avoid drilling. To create bespoke posts, please refer to page 28.

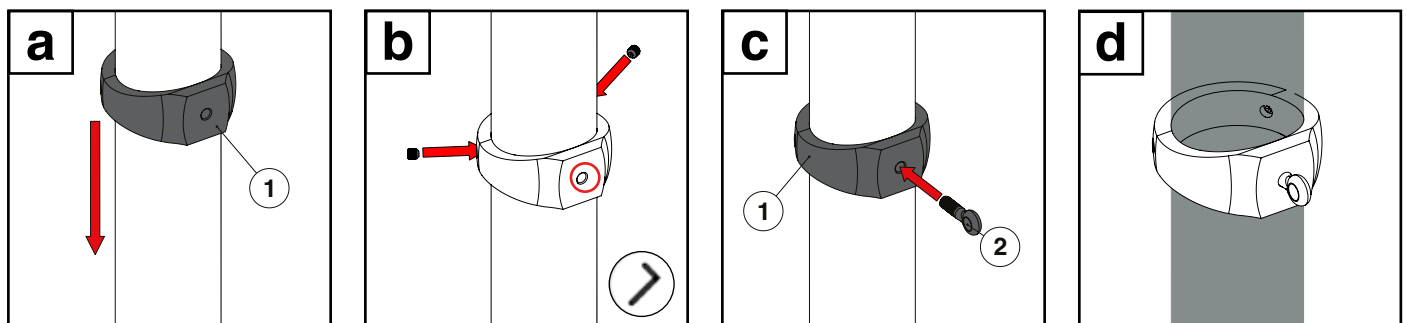

Slide post fitting adaptor ring 1 onto the post

Remove third grub screw from the front and throw away.

Screw eye bolt 2 into adaptor ring 1 in until hits the post.

ID	Description	Size	To Suit Wire Ø mm	Finish	Code
1	Eye bolt Connector	M6	3	Stainless 316	1806603
2	Post Fitting Adaptor Ring	Ø 48.3mm	3	Stainless 316	1806335D

Bespoke Posts

A number of our wire rope systems require bespoke posts or have flat components that can be used on square posts. Bespoke posts allow you the flexibility to design a post to your systems specific design needs. Below is a break down our components that can be used to create bespoke posts and how to assemble them.

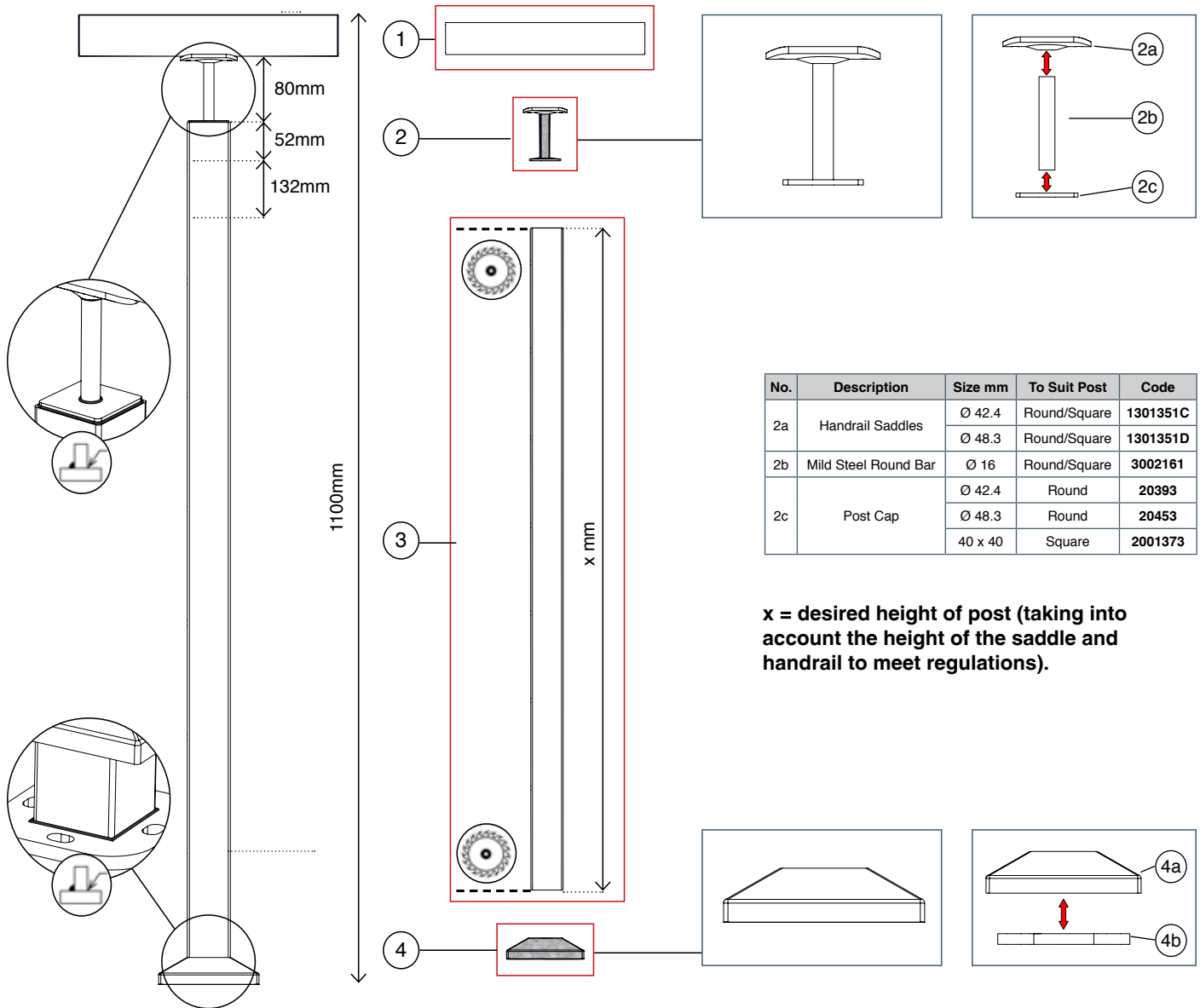

Posts	1. Handrail	+	2. Spigot	+	3. Box Section	+	4. Base	Suitable Systems
Ø 42.4mm	Stainless Steel							
	1806700C		1806310CC (Fixed) 1806312CC (Adjustable)		1806708CL		1806207C (Base Plate)	Systems 1,2, 3,4,5
	Mild Steel							
	300648332		*see Item 2 table above		300648332		1301207C (Cover Plate) 1301207C (Base Plate)	Systems 1,2, 3,4,5
Ø 48.3mm	Stainless Steel							
	1806700D		1806310DD (Fixed) 1806312DD (Adjustable)		1806708DL		1806207D (Base Plate)	Systems 1,2, 3,4,5
	Mild Steel							
	300642432		*see Item 2 table above		300642432		130120840 (Cover Plate) 130120740 (Base Plate)	Systems 1,2, 3,4,5
Square	Stainless Steel							
	1806704D / 1806700D		1806312S40C (Round) 1806312S40F (Square)		180670S40 / 1806700S40 (Square)		1301207D (Cover Plate) 1301207D (Base Plate)	Systems 1,2,4,5
	Mild Steel							
	300540403		*see Item 2 table above		300540403		130120840 (Cover Plate) 130120740 (Base Plate)	Systems 1,2,4,5

Our wire rope systems look stylish and professional. It is important for customers to carry out maintenance from time to time to uphold this appearance for years to come.

Care & Maintenance

Stainless steel is often selected for corrosion resistance and appearance. However, the term stainless is somewhat misleading as stainless steel will discolour or stain over time due to surface deposits. It may stain less, but it will still stain and should be treated correctly to avoid contamination.

The amount of cleaning required will vary according to the finish; local conditions, location and use, and therefore it is not a maintenance free product. To gain the maximum resistance against corrosion, cleaning must be carried out on a regular basis, resulting in good performance and a long life.

Basically, the only rule is that if the metal is dirty, then it should be cleaned to restore its original appearance.

For external stainless steel Grade 316, we would recommend that inspection and maintenance should be carried out every 6 – 12 months depending on location and appearance requirements.

There are a number of cleaning agents available which are safe to use when manufacturers instructions are followed, however if used incorrectly (e.g. too concentrated) they may cause discolouration or even corrosion. Stainless steel will not wear out from excessive cleaning.

During Assembly

We suggest sealing with our clear general purpose silicone (code: **189901201**). Disassemble the component, fill the cavity and jaw housing with the sealing component and assemble again. This should be repeated until the silicone emerges from the hole through which the cable is inserted, after which you should clean the terminal.

Check the terminal regularly for damage. Regularly check the seal and if broken proceed by removing all the silicone, rinse the terminal with fresh water and then treat with WD40. Proceed to resealing the terminal with the silicone.

Further Cleaning for Stainless Components

1. Basic cleaning can be done simply with warm water and a our low lint textelene Cloths (code: **29RT150**) then dried with a soft cloth to prevent streaks. Wipe in the direction of the polish lines.
2. Add a mild detergent to warm water for dirtier stains.
3. Finger prints can be removed with our stainless cleaning wipes (code: **189900901**) or bond it glass cleaner (code: **1859GC1**). Alternatively, rinse and dry with a soft cloth such as our low lint textelene cloths (code: **29RT150**).

Further Cleaning Products:

3 part tea staining treatment cleaner kit (code: **189900902**) is especially suitable for maintenance of aesthetic stainless steel objects; the Pro-Railing® protect spray provides protection and a natural shine.

Pickling gel (code: **18990094023**) helps remove rust, dirt and grime from stainless steel.

Loctite 7063 cleaner (code: **18990097063**) degreases and cleans surfaces ready for gluing, which could be helpful with our swaged components that require the instant adhesive (code: **1899007454**).

For further information, please see the British Stainless Steel Association Recommendations for Care & Maintenance

Please refer to BSSA Information Sheet No.7.20 entitled Care & Maintenance of Stainless Steel.
www.bssa.org.uk or telephone 0114 267 1265

Safety Data Sheets and Testing

[LOCTITE® 454 Instant Adhesive](#)

[LOCTITE® 5366 Clear General Purpose Silicone](#)

The Stainless Steel Handrail Component System

PRO-RAILING®