

2.3 Dimensions

ENGLISH

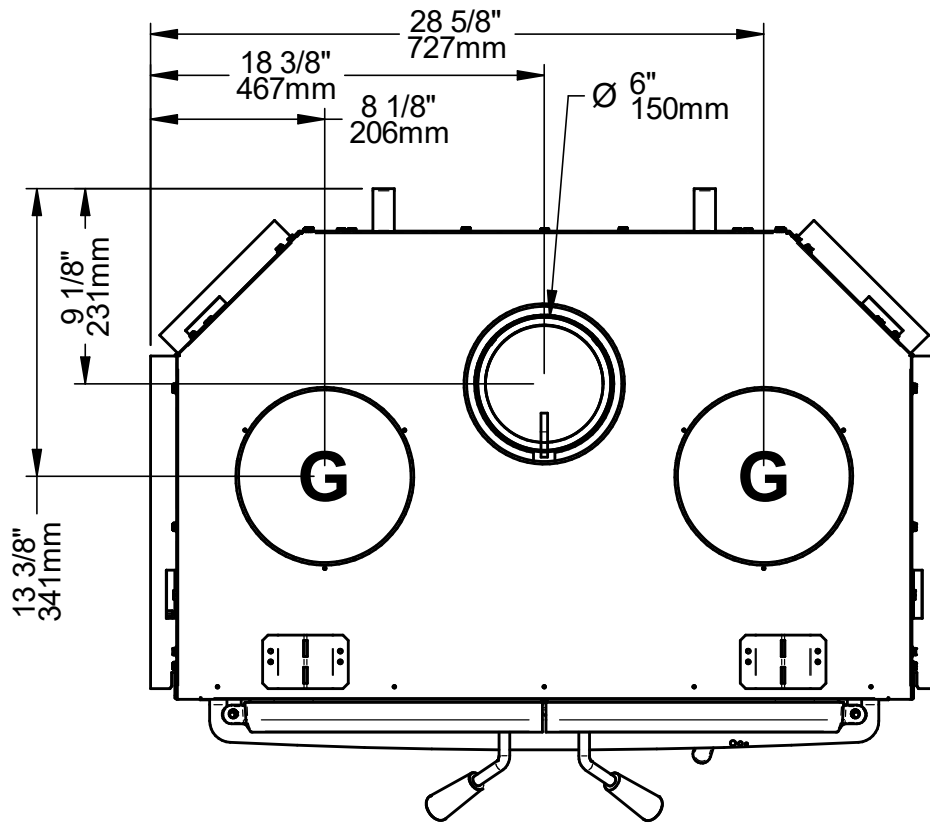

Figure 1: Top view

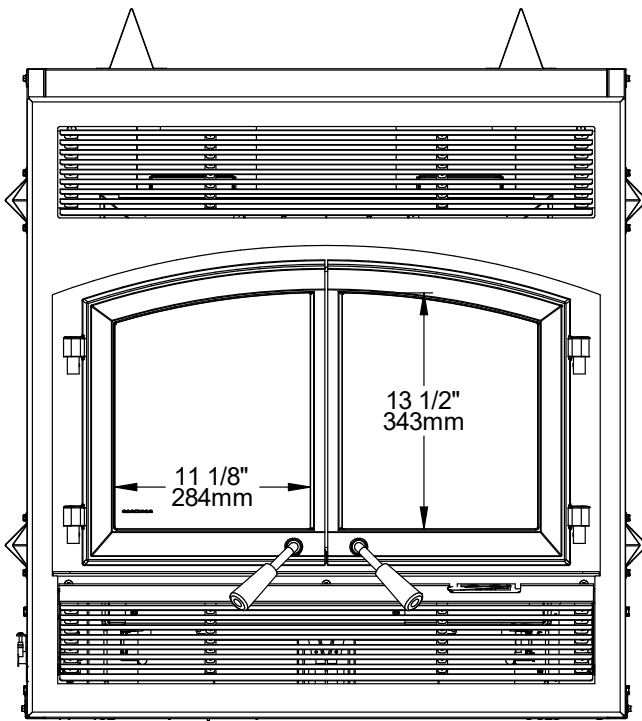

Figure 2: Front view

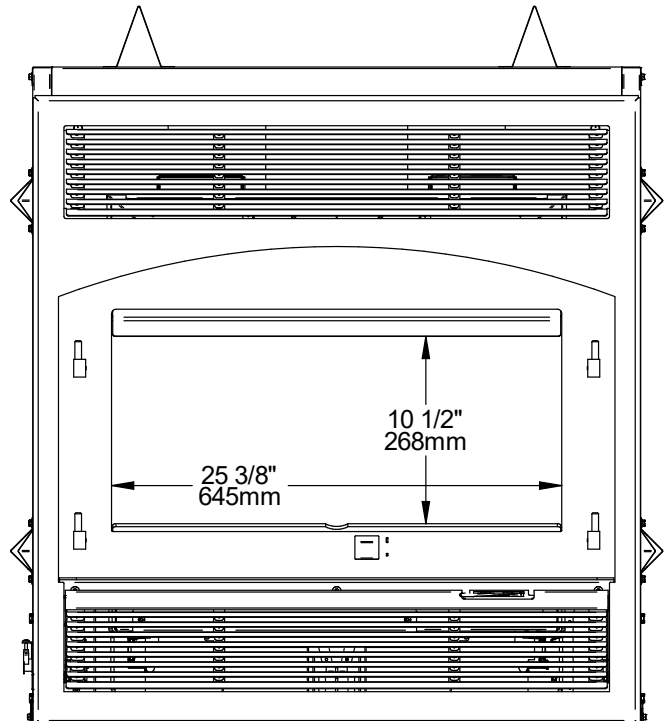

Figure 3: Front view - Door opening

G : Opening for gravity hot air distribution kit (ø 8").

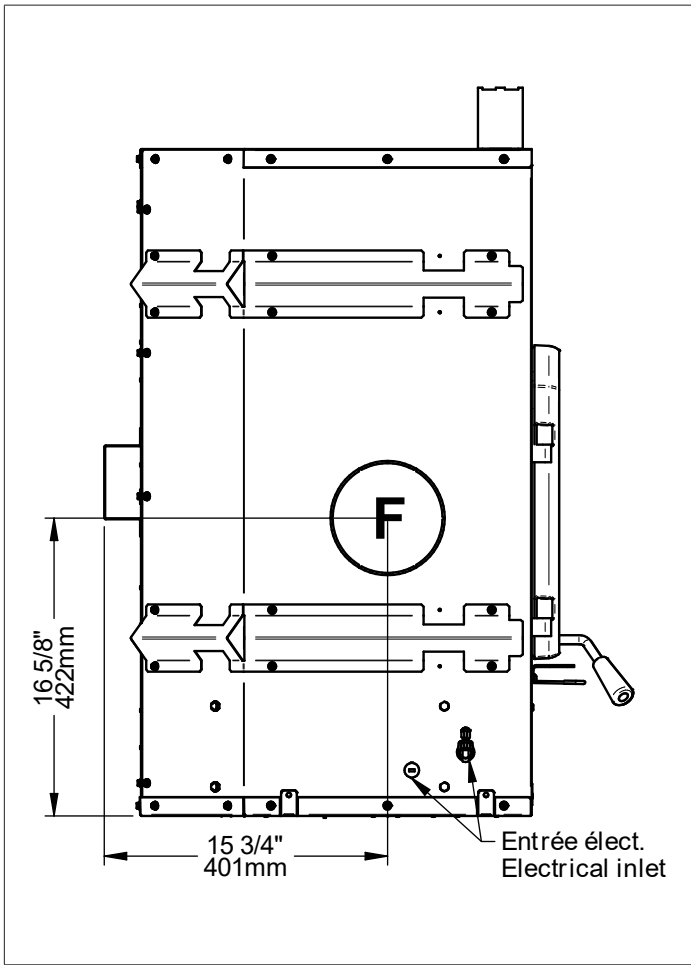

Figure 4: Left side view

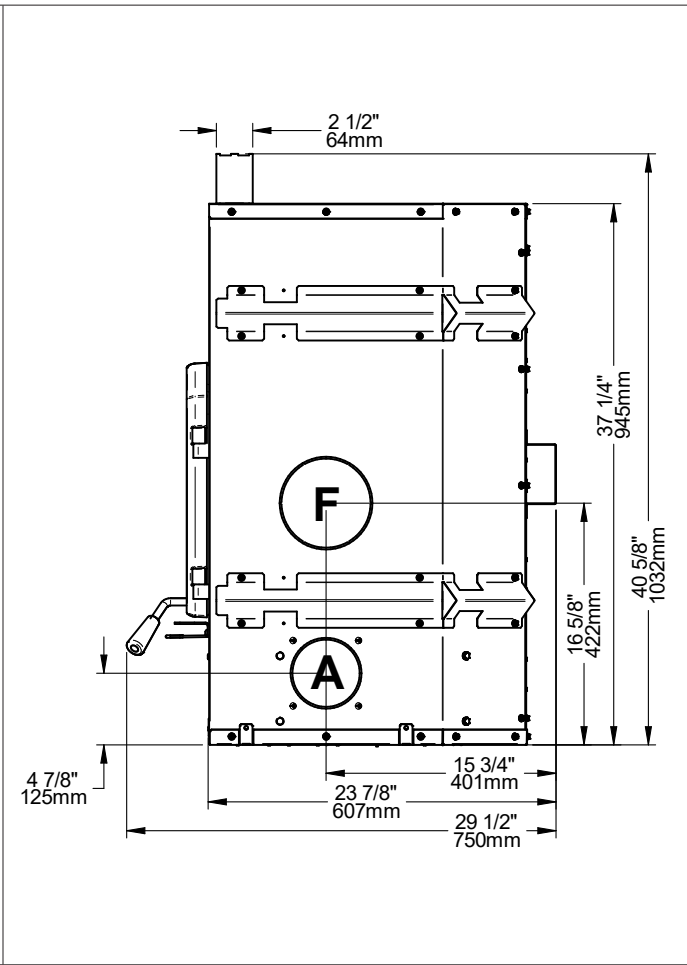

Figure 5: Right side view

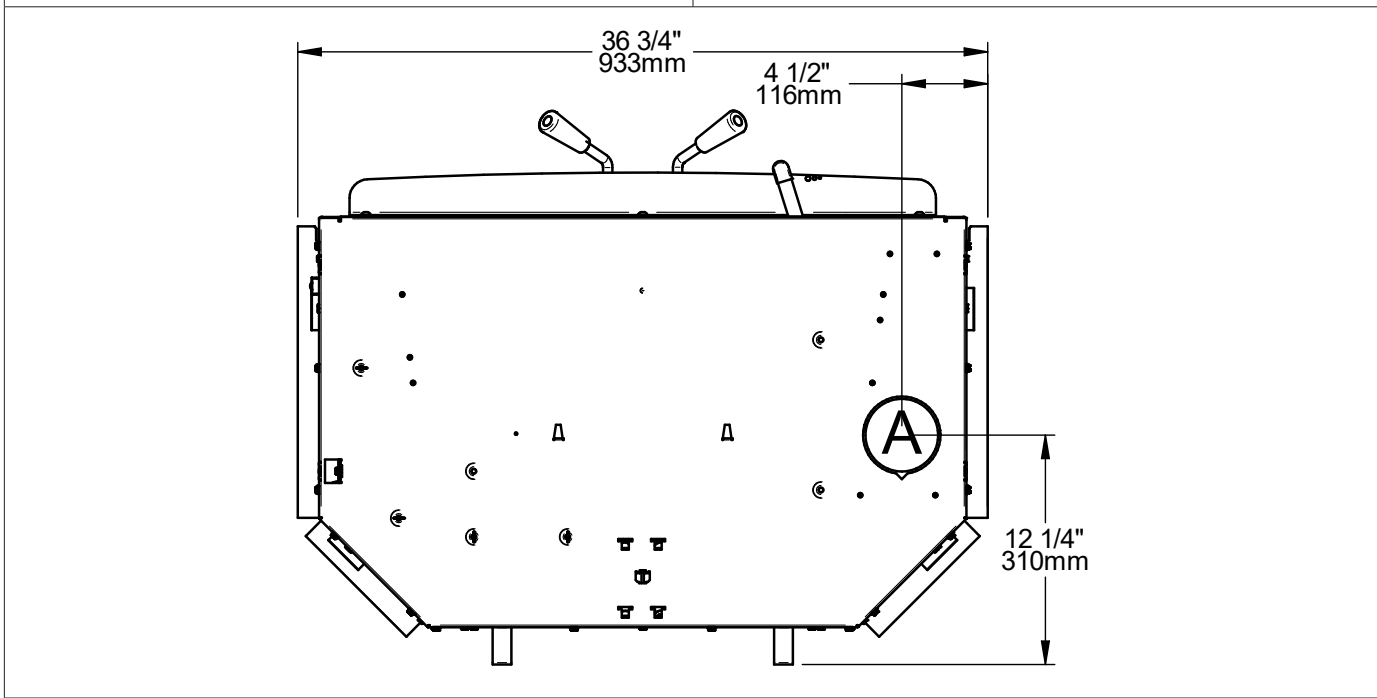

Figure 6: Bottom view

F : Opening for forced air distribution kit (ø 6").

A : Opening for fresh air intake (ø 4").

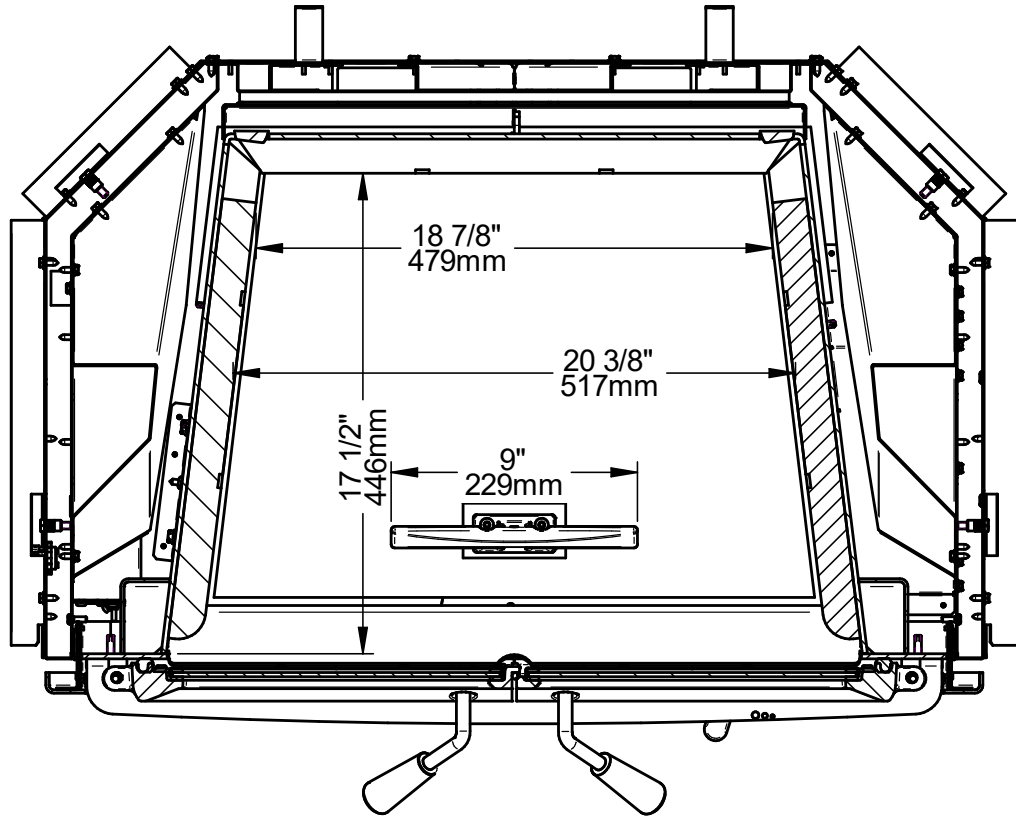

Figure 7: Combustion chamber - Top view

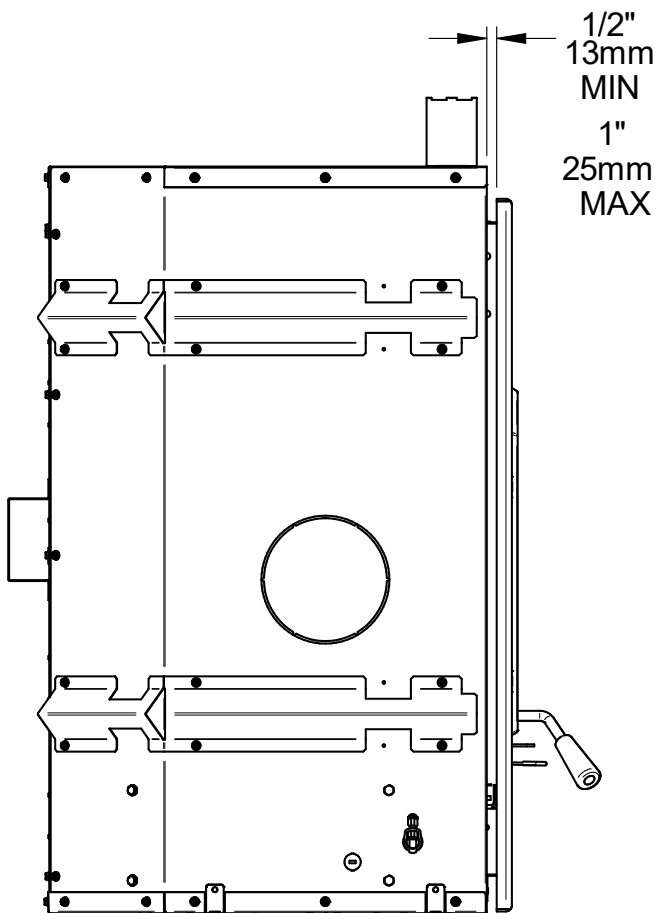

Figure 8: Left view - Faceplate projection

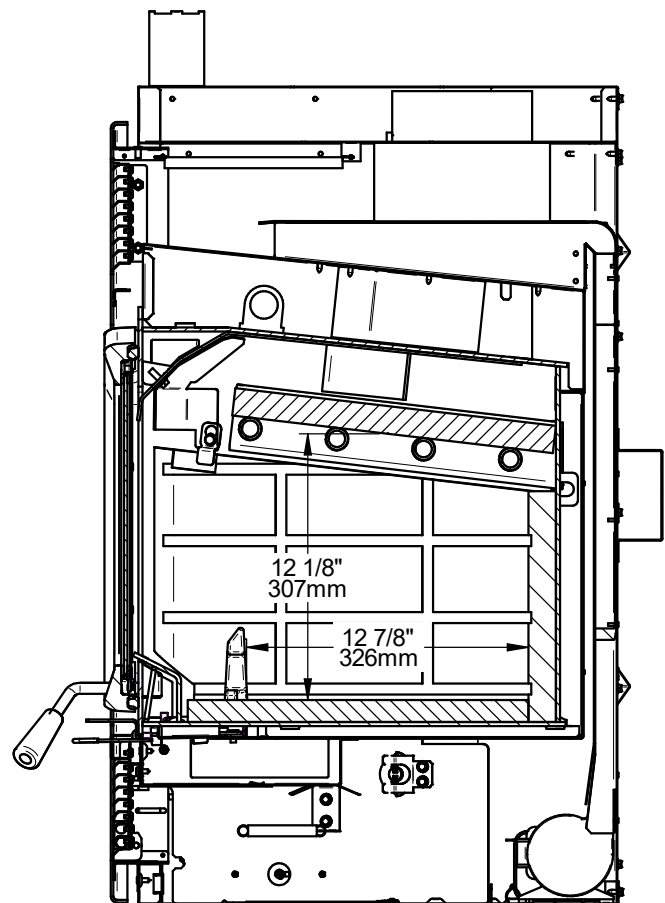

Figure 9: Combustion chamber - Side view