

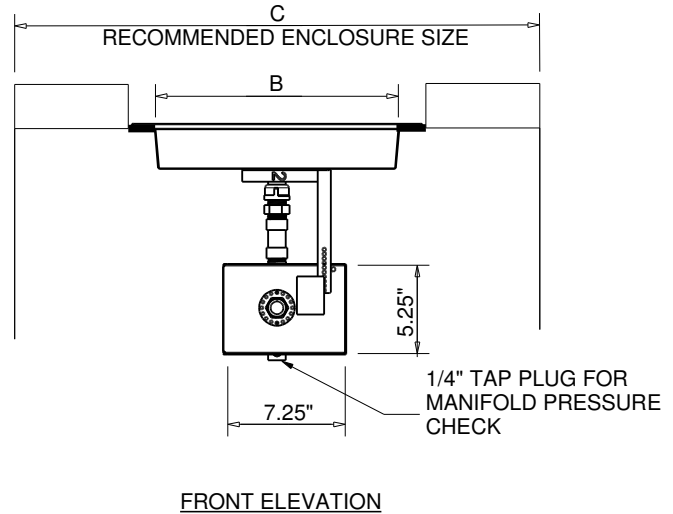

Hearth Products Controls Co
CSA CERTIFIED-OUTDOOR USE ONLY
FOR COMMERCIAL AND RESIDENTIAL USE

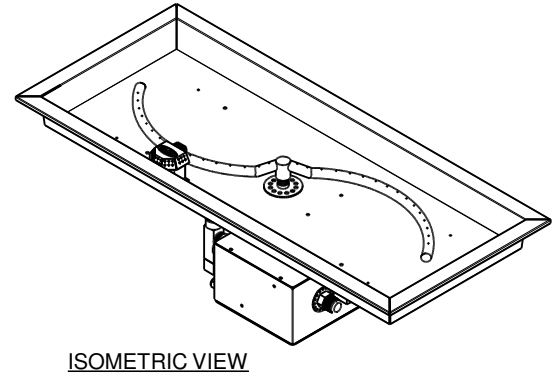
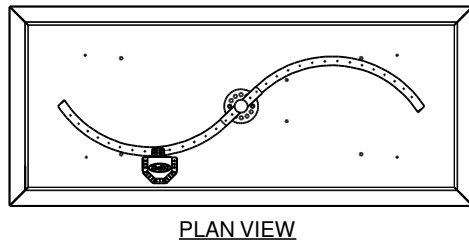
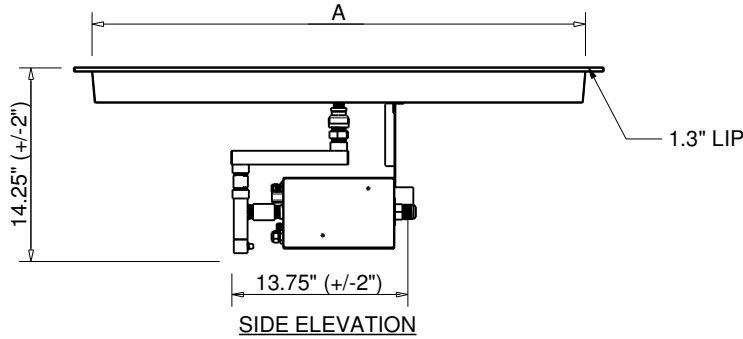

AVAILABLE IN:

- 120VAC OR 24VAC
- On/Off OR Hi/Low

MATERIAL: 304 STAINLESS STEEL

Hi/Lo MODELS HAVE A 40% REDUCTION IN BTU ON LOW SETTING

PART NUMBERS	STND BTU	DIMENSION CHART		
		A"	B"	C"
36X14SSEI-S	75K	36	14	64LX32W
42X14SSEI-S	85K	42	14	64LX32W
54X16SSEI-S	110K	54	16	76LX38W
66X16SSEI-S	135K	66	16	88LX38W
78X16SSEI-S	165K	78	16	90LX38W

Notes:

1. PROPER VENTING

- ENCLOSURES: Recommend 4 each 18 sq.in. vents on opposing sides (Minimum 2 each 18 sq.in. vents).
- BOWLS (Copper, concrete or metal) - Bowl to be raised above mounting surface minimum of 3/4" gap; Bowl to have a minimum of 6" diameter hole in bottom

2. GAS SUPPLY - FOR USE WITH FIXED PIPING SYSTEMS ONLY - NOT FOR USE WITH SMALL TANKS.

- Natural Gas: Operating Supply Pressure: Minimum: 6.0" W.C.; Maximum: 7.0" W.C.
- LP Gas: Operating Supply Pressure: Minimum: 10.0" W.C.; Maximum: 11.0" W.C.

IMPORTANT: Ensure any flex line that may be used from the permanent main fuel supply to the product is rated to the stated max btu of the product and certified to ANSI Z21.75*CSA 6.27.

5. MODIFICATION OF PRODUCT WILL VOID ANY CERTIFICATION AND WARRANTY.
6. FOLLOW ALL MANUFACTURER INSTALLATION INSTRUCTIONS AND LOCAL CODES.
7. ALL DIMENSIONS ARE CONSIDERED TRUE AND REFLECT MANUFACTURER'S SPECIFICATIONS AS OF THE REVISION DATE.
8. DO NOT SCALE DRAWING.
9. THESE DRAWINGS ARE FOR SIZING AND PLANNING PURPOSES. ALL INFORMATION CONTAINED HEREIN WAS CURRENT AT THE TIME OF DEVELOPMENT. THE MANUFACTURER'S RESPONSIBLE FOR THE ACCURACY OF THE DRAWING.
10. CONTRACTOR'S NOTE: FOR PRODUCT AND COMPANY INFORMATION VISIT www.CADdetails.com/info REFERENCE NUMBER 771-052.

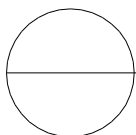

ELECTRONIC IGNITION

EI RECTANGLE - SFIRE - FLAME SENSING WITH ELECTRONIC HOT SURFACE IGNITION