

DUNE

QUATER series



HELMETS SAVE LIVES!

Always wear a properly fitted helmet that complies with CPSC or CE safety standards when you ride your scooter.



Correct Fitting:

Make sure your helmet covers your forehead.

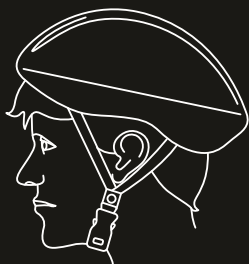

Incorrect Fitting:

Forehead is exposed and vulnerable to serious injury.

WARNING

As with all mechanical components, the DUNE is subjected to wear and high stresses. Different materials and components may react to wear or fatigue in different ways. If the design life of a component has been exceeded, it may suddenly fail possibly causing injuries to the rider. Any form of crack, scratch or change of coloring in highly stressed areas indicate that the life of the component has been reached and it should be replaced. Do not ride in an abusive manner.

CAUTION

In this manual, the CAUTION sign indicates a hazardous situation which, if not avoided, can cause minor or moderate injury.

WARNING

In this manual, the WARNING sign indicates a hazardous situation which, if not avoided, can cause death or severe injury.

INTRODUCTION

This manual designed to give you the information you need for the safe operation and maintenance of your DUNE Please read it thoroughly before riding your DUNE.

WARNING

Make sure you read this complete manual before riding your DUNE. Failure to do so, or failure to follow its guidelines could lead to severe injury or death.

The DUNE is a personal transporter. Our technology and production processes are developed with strict testing for each DUNE Electric Scooter. Operating the DUNE without following the contents of this manual may lead to damage to your DUNE, or bodily injury.

PACKAGE CONTENTS

- DUNE Electric Scooter
- Key with Remote
- Charging Cable
- Operation Manual
- Rear View Mirrors

This item is not a toy, it is not recommended for riders under the age of 18.

Your DUNE 's serial number is stamped respectively on steering column and battery column as shown below. Record the serial number for your reference.

BATTERY CARE

BATTERY MAINTENANCE

The Lead-acid battery is built into the device. Do not disassemble the device to remove the battery or attempt to separate it from the device.

- When charging the device, only use the enclosed DUNE charging cable assigned to this device.
- Do not connect or attach the device or the battery to a power supply plug or directly to a car's cigarette lighter.
- Do not place the device or batteries near a fire, or into direct sunlight. Heating the device and/or the battery can cause additional heating, breaking, or ignition of the battery inside the device.

- Do not continue charging the battery if it does not recharge within the specified charging time. Doing so may cause the battery to become hot, rupture, or ignite.

To preserve natural resources, please recycle or dispose of batteries properly. This product contains Lead-acid batteries. Local, state, or federal laws may prohibit disposal of Lead-acid batteries in ordinary trash. Consult your local waste authority for information regarding available recycling and/or disposal options.

WARNING

Failure to follow the safety precautions listed below could lead to serious bodily injury and/or death.

- Do not use your device if the battery begins to emit odor, overheats, or begins to leak.
- Do not touch any leaking materials or breathe fumes emitted.
- Do not allow children and animals to touch the battery.
- The battery contains dangerous substances, do not open the battery, or insert anything into the battery.
- Do not attempt to charge the device if the battery has discharge or emits any substances. In that case, immediately distance yourself from the battery in case of fire or explosion.

BEFORE RIDING

WARNING

Any DUNE that does not work properly can cause you to lose control and fall. Inspect the entire device thoroughly before every ride, and do not ride it until any problems have been corrected.

RIDER OPERATION

It is important that you fully understand all elements of your DUNE. If these elements are not used correctly, you will not have full control of your DUNE. Before you ride fast, or outside of a controlled environment, learn the functions of the various mechanisms on your DUNE.

PRE-RIDE DUNE CHECKLIST

Ensure that your DUNE is in proper working order each and every time you ride. If a part of the DUNE does not function correctly, please contact our Customer Support Center.

- Always wear a helmet that meets CPSC or CE safety standards. In the event of an accident, a helmet can protect you from severe injury and in some cases, even death.

WARNING

Any scooter that does not work properly can cause you to lose control and fall. Do not ride a DUNE with a part that is damaged; replace the damaged part before riding.

- The owner shall only use and operate the unit after full comprehension of all components and functions of the unit...
- Check with your doctor if you have a medical condition that could affect your ability to use the DUNE.
- Persons with a medical condition, heart condition, head, back, or neck ailments or prior surgeries to those areas of the body are not recommended to use the DUNE.
- Persons with any mental or physical conditions that may make them susceptible to injury or impair their physical or mental capabilities to recognize, understand and perform all of the safety instructions and to be able to assume the hazards inherent in unit use, should not use the DUNE.
- Ensure your tire pressure is at 30 psi(210kpa) before riding.
- Ensure the battery is fully charged before riding your DUNE.

CAUTION

Only use the enclosed charging cable and charger to charge your DUNE. Using any other unauthorized charger may damage your DUNE.

- Make sure that there is no dust, debris or inside the port.
- Locate the charge cable and plug the male end into a grounded wall outlet.
- Plug the female end in the scooter's charge port.
- The charging indicator light on your charger should change to RED, indicating that your device is now being charged.
- When the RED indicator light on your charger turns to GREEN, then your device is fully charged.
- A full charge may take up to 10 hours.
- After fully charging your scooter, unplug the charge cable from the power outlet.
- Lift the charge port flap back up and push in to secure it back into place.

SAFETY PRECAUTIONS

- If the DUNE is not to be used for an extended period of time, you may need to recharge the battery every 2 months to maintain the battery life.
- Ensure that the screws on the front and back tires are locked firmly before each ride.
- Check to ensure the tires are not worn.
- Check to ensure all connections are maintained on the DUNE.

- Ensure the brake cables are well lubricated. It is suggested you Lubricated brakes every 6 months.
- Ensure throttle moves smoothly. You should be able to turn it forward and back.
- Make sure there are no frayed cables, loose connections, missing fasteners or axle/lug nuts.

CHECKING BRAKES

A cable connects the brake lever to your brakes. The lever causes the brake pads to apply pressure to the rotos on your wheels.

Pull the lever to ensure the brake moves freely and stops the DUNE. If the lever can be pulled flat to the handlebar, the brake is too loose.

When brakes are not applied, brake pads should be 1-2mm form the rotor. if brake pads are too close to the rotor, the brakes are too tight. The brake pads should be in line with the rotor surface.

Adjust your brake lever to improve brake sensitivity. Brakes will wear down over time. If after you have adjusted brake sensitivity, you feel that the brakes are not performing well, you may need to have brake pads or rotors replaced.

The first rule in safe riding is to use common sense. A DUNE is vulnerable; it cannot protect you in a crash, against impact, or loss of control the way driving a car can. A DUNE can tip over sideways or pitch you over the front wheel. It moves faster than a typical scooter. It does not have bumpers or airbags as a car does.

This section is a guide of safe riding practices. Make sure you are using your DUNE properly.

CAUTION

Brake pads and rotors get very hot during use and could burn shin. The edges can also be very sharp and cut skin. do not touch the brake pads or rotors directly after riding your DUNE.

Different localities and countries have different laws governing riding on public roads, and you should check with local to ensure you are complying with these laws.

DUNE is not liable for tickets or violations given to riders who do not follow these regulations.

- Always wear a helmet that meets CPSC or CE safety standards. In the event of an accident, a helmet can protect you from severe injury and in some cases, even death.
- Obey all local traffic laws. Obey red and green lights, one-way streets, stop signs, pedestrian crosswalks, etc.
- Ride with the traffic, not against it.
- Ride defensively; expect the unexpected.
- Give pedestrians the right-of-way.
- Do not ride too close to pedestrians and alert them if you intend to pass them from behind.
- Slow down at all street intersections and look to left and right before crossing.
- Obey all Traffic signals.
- Always use proper hand signals for turning and stopping. Give signals before stopping or turning and always return both hands to the handlebars before stopping or turning.
- Watch for cars pulling out into traffic and for the sudden opening of car doors.
- Avoid potholes, drainage grates or other road surface hazards.
- Never hitch onto other vehicles.
- Do not “stunt” ride or race in traffic.

WARNING

Proper use of your brake is vital to ensure safe, efficient stopping. To avoid misuse and potential injury, do not apply sudden or excessive force to your brakes. Apply your brakes gradually and give yourself enough room to come to a complete stop safely.

- Do not weave in and out of traffic or swerve from side to side.

- A crash can put extraordinary stress on DUNE components, possibly causing them to fatigue prematurely. Components suffering from stress fatigue can fail suddenly, causing loss of control, or serious injury.

CAUTION: RIDING IN WET WEATHER

Brakes do not work as well under wet conditions as they do when dry. It is recommended that you do not ride your DUNE in wet weather, as there are electronic components of your DUNE that may be damaged if exposed to water.

If you are riding your scooter in low-visibility conditions, ensure your headlight is turned on, and that you are wearing bright, reflective clothing.

Think about safety when you ride. You can prevent many accidents if you think about safety. Below is a helpful checklist for DUNE riders.

SAFETY CHECKLIST

- Check your scooter before every ride, making sure brakes are operating effectively and everything is in good working condition.
- Always keep both hands firmly on the handlebars.
- Do not ride “double” with more than one adult rider on the seat.
- Avoid riding in large groups, as this can force you to ride too close to other riders, making it difficult to see other vehicles and road hazards.
- Do not ride above your skill level. Ensure you have had enough practice with all functions and features of your Rider.
- With increased speed comes increased risk. If you are moving at a higher speed, small bumps can turn into large impacts, leading to a higher risk of injury if an accident occurs.

WARNING

When you ride in low-visibility conditions such as fog, dusk, or night, you might be difficult to see, which could lead to a collision. In addition to keeping your headlight on, wear bright, reflective clothing when riding in poor lighting conditions.

- Do not ride with loose objects attached to the handlebars or other parts of the scooter.
- Do not ride while intoxicated or while taking medications which can make you drowsy.
- When approaching a descent, decrease your speed.
- Do not abuse your DUNE.

Always look ahead to avoid and anticipate any upcoming obstacles. The distance of any upcoming obstacles will vary according to your speed.

WARNING

There may be additional risk to injury if you use your scooter incorrectly. This includes, but is not limited to:

- Jumping your scooter
- Riding over debris or obstacles
- Performing stunts
- Riding in off-road terrain
- Racing other riders
- Riding in unusual manner

The aforementioned examples add stress to each part of your scooter and can lead to long term damage of the device. Damage to your scooter can lead to an accident or increase your risk of injury. To decrease your risk of injury, use your scooter correctly.

Use caution when you encounter road obstacles. If you are going fast, even a small obstacle can create a significant impact to both you and your scooter. If you are unsure about your ability to safely ride over an obstacle, it is best to either ride around it, or stop your scooter, dismount, and walk your scooter around the obstacle.

The natural tendency of riders is to move where they are looking. Avoid focusing on obstacles, even if you are trying to avoid them. Instead, focus on the part of the road where you want to go.

OPERATING CONDITIONS

FAILURE TO FOLLOW ANY OF THE FOLLOWING SAFETY PRECAUTIONS CAN AND MAY LEAD TO DAMAGE TO YOUR DEVICE, VOID YOUR MANUFACTURER WARRANTY, LEAD TO PROPERTY DAMAGE, CAUSE SERIOUS BODILY INJURY, AND CAN LEAD TO DEATH.

OPERATING YOUR DEVICE

Make sure the device is fully charged before the first initial use. Before turning on your scooter, sit on it like a normal bike to get comfortable with the device before using it with the motor.

The scooter is equipped with a built-in 1000-Watt Brushless Motor which allows you to accelerate (up to 25 km/h) and decelerate.

To turn, use the handlebar to turn in the direction you wish to turn. prepare to brace yourself if you encounter bumps or uneven surfaces, then dismount and roll your scooter to a safe operating surface.

WEIGHT AND SPEED LIMITATIONS

Speed and weight limits are set for your own safety. Please do not exceed the limits listed here in the manual.

- Maximum Weight: 100 kg
- Maximum Speed: Up to 25 km/h

WARNING

Overweight exertion on product may increase possibility of injury or product damage.

OPERATING RANGE

The scooter can travel a distance up to 50 km on a fully charged battery in ideal conditions. The following are some of the major factors that will affect the operating range of your device.

- **Terrain:** Riding distance is highest when riding on a smooth, flat surface. Riding uphill and/or on rough terrain will reduce distance significantly.
- **Weight:** A lighter user will have further range than a heavier user.
- **Ambient temperature:** Please ride and store the device under recommended temperatures, which will increase driving distance; battery life, and overall performance of your device.
- **Speed and Riding Style:** Maintaining a moderate and consistent speed while riding produces maximum distance. Traveling at high speeds for extended periods, frequent starts and stops, idling and frequent acceleration or deceleration will decrease overall distance.

WARNING

Any scooter that does not work properly can cause you to lose control and fall. Inspect the entire scooter thoroughly before every ride, and do not ride it until any problems have been corrected.

WARNING

Do not turn sharply or at high speeds to avoid danger. Do not turn or ride quickly along slopes, as it may cause injury.

CARE & MAINTENANCE

- Do not expose the device to liquid, moisture, or humidity to avoid damage to the product's internal circuitry.
- Do not use abrasive cleaning solvents to clean the device.
- Do not expose the device to extremely high or low temperatures as this will shorten the life of the electronic device, destroy the battery, and/or destroy certain plastic parts.
- Do not dispose of the device in fire as it may explode or combust.
- Do not expose the device to contact with sharp objects as this will cause scratches and damage.
- Do not let the device fall from high places, as doing so may damage the internal circuitry.
- Do not attempt to disassemble the device.
- Use only the charger provided by DUNE

WARNING

Avoid using water or other liquids for cleaning. If water or other liquids enter the scooter, it will cause permanent damage to the internal components.

DUNE DIAGRAM

FEATURES/PARTS



1. Rear-view Mirror
2. Headlight
3. Front brake
4. Turning light
5. Tire
6. Disc brake
7. dashboard
8. Throttle
9. Seat
10. Charge Port
11. Taillight
12. Anti-tip wheels

HANDLEBAR DIAGRAM



- | | |
|------------------------------|-----------------------------|
| 1. Rear Brake | 7. Turn Signal Switch |
| 2. Parking Brake | 8. Horn |
| 3. Low Beam/High Beam Switch | 9. Ignition |
| 4. Meter Display | 10. Light Switch |
| 5. Forward / Reverse Switch | 11. Horn |
| 6. Front Brake | 12. Speed Adjustment Button |
| | 13. Throttle |

SPECIFICATIONS

Model:	DUNE
Load:	100kg
Max Speed:	Up to 25km/h
Max Distance Range:	Up to 50 km
Max incline Angle:	20° degrees
Min Clearance:	5 Inches (12.7cm)
Brake Type:	Front Disk Brake and Rear Drum Brake
Shock Absorption:	Front Frame Suspension Fork, Rear Two Heavy-Duty Shock Absorbers
Hand Height:	37 Inches (93.98cm)
Tire Size:	3 Inches width (7.62cm) 90% Span ratio 10 Inches diameter (25.4cm)
Motor:	1000W
Charge Time:	Up to 8 hours
Battery Type:	Lead-acid
Battery Voltage:	60 V
Battery Capacity:	20 Ah
Power Requirement:	AC 100-240V,50-60Hz

NOTE: Max speed and max distance may vary depending on, but not limited to: user load, terrain of road, operation temperature, driving habits and environmental temperatures.

IGNITION

1. TURNING ON SCOOTER

Turn key clockwise to “C” to turn on scooter engine.

2. TURNING OFF SCOOTER

To turn scooter off, turn the key to “OFF”.

3. LOCK

Push key in and turnkey to “A” to lock scooter.

4. OPEN SEAT

Turnkey to the right to open the seat.



CONTROLS & DISPLAY

1. SPEEDOMETER

Displays current speed in mph.

2. TURN SIGNAL

Indicates left or right turning signal.

3. LIGHT INDICATOR

Indicates if headlights are on/off.

4. BATTERY LIFE INDICATOR

Displays your remaining battery life.



REMOTE

1. LOCK

Press once to activate arm.

2. UNLOCK

Press once to disarm alarm.

3. ALARM

Press once to sound alarm.

4. REMOTE START

Press twice to remotely start scooter. This will work within a 15-foot range of your scooter.



Your Rider comes with a seat compartment for extra storage and to house your battery.

To access the seat compartment simply put the key in the ignition and turn it to "OPEN".

Beneath the storage area, you will find the:

1. Main Circuit Breaker
2. Rechargeable Battery Compartment

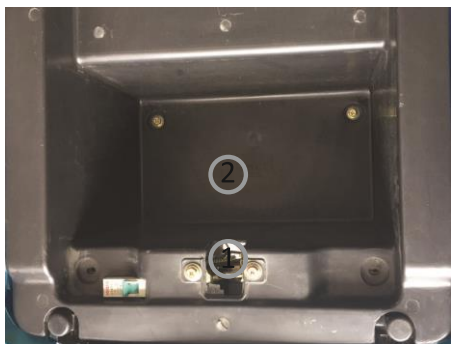

ATTACHING REAR-VIEW MIRRORS

1. Remove the rear-view mirrors from the box.
2. Attach the rear-view mirrors by screwing the mirrors (with posts) into the grommets shown in the diagram below.



- Locate the charging port underneath the front end of the seat.



- Lift the charging port flap to reveal the charging port.



RIDING YOUR RIDER

After reviewing the pre-ride checklist, follow the steps below to begin riding your Rider.

1. Ensure parking brake is off. The Parking Brake is located on the left-hand brake. The tab holds tension in the brake lines to keep the unit stationary when not in use.

Activate your parking brake by pressing this tab towards the brake handle while squeezing the left-hand brake. They will click inwards.

To deactivate your parking brake, squeeze the left-hand brake to release the Parking Brake tab.



2. Insert the key into the ignition and turn clockwise to the "ON" position to turn on your Rider.
3. The Meter Display will turn on.
4. Set your max speed by the three-position speed-switch.

"I"- max speed: 10 km/h.

"II"- max speed: 19 km/h.

"III"- max speed: 25 km/h.



5. Turn the Throttle towards yourself slowly. The DUNE will begin to move forward.



6. When the DUNE begins to move forward, put your feet in front of you on the Foot Rest. Your speed will be determined by the turn of the throttle and your speed level setting.



7. To stop your Rider, release the throttle and squeeze to apply your Front & Rear Brakes with both hands slowly until you reach a complete stop.



*Do not attempt to stop suddenly as this may lead to injury or damage to your brake discs.

WARNING

Proper use of your brake is vital to ensure safe, efficient stopping. To avoid misuse and potential injury, do not apply sudden or excessive force to your brake. Apply the brake gradually and give yourself enough room to come to a complete stop safely.

Please follow all local, state and federal laws regarding recycling, handling and disposing of Lead-acid batteries.

- Lead-acid batteries are hazardous materials. Please follow all local, state and federal laws regarding recycling, handling and disposing of Lead-acid batteries.

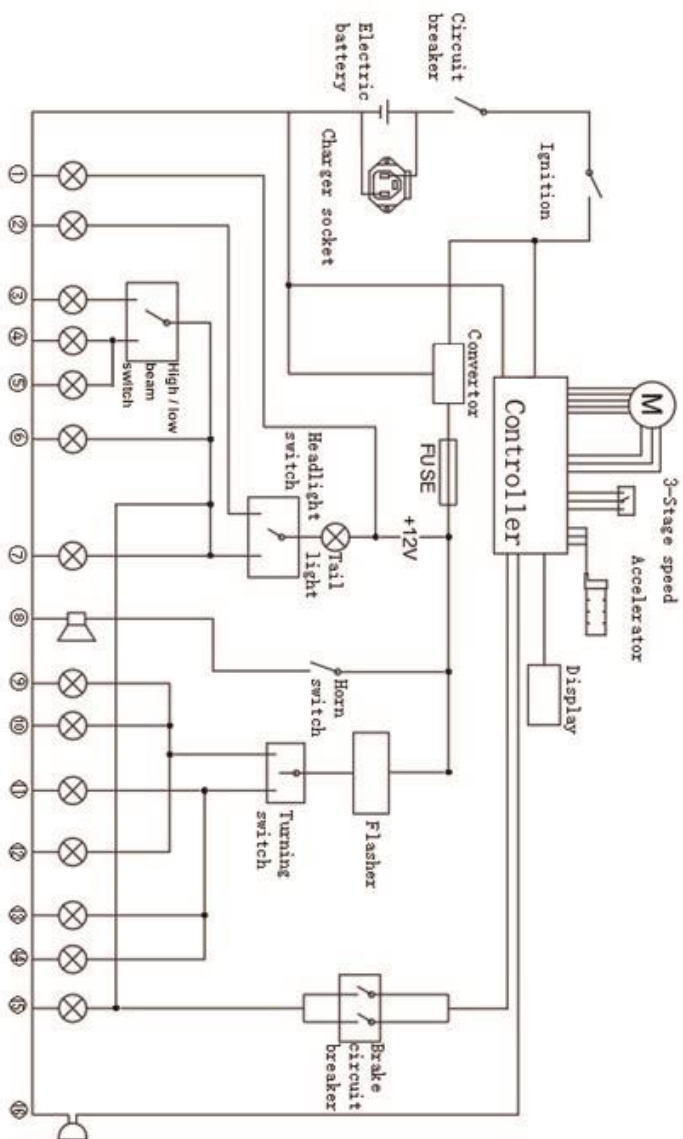

- ① Daytime running light
- ② Night traffic lights
- ③ Low beam
- ④ High beam
- ⑤ High beam indicator
- ⑥ Display light
- ⑦ Number plate light
- ⑧ Horn
- ⑨ Left turn indicator
- ⑩ Front left turning light
- ⑪ Front right turning light
- ⑫ Rear left turning light
- ⑬ Rear right turning light
- ⑭ Right turn indicator
- ⑮ Brake light
- ⑯ Reverse buzzer

WARRANTY

1 year for warranty or up to 6000 km. Part replacement to original owner. Need original purchase invoice.

Batteries and charger 6 months.

Affix Serial Number Label Here

DESIGN

DUNE is designed to be easily controlled, providing a safe, stable form of travel. The built-in rechargeable battery allows you to power up whenever you travel. The ultra bright LED headlight and brake lights provide safety as you explore your surroundings. The rider requires 8 hours of charging for a full charge.

PERFORMANCE

DUNE is a modern electric scooter equipped with a powerful motor responsive brakes, making it easier and safer. to control, allowing you to travel up to 50 km at up to 25 km/h.

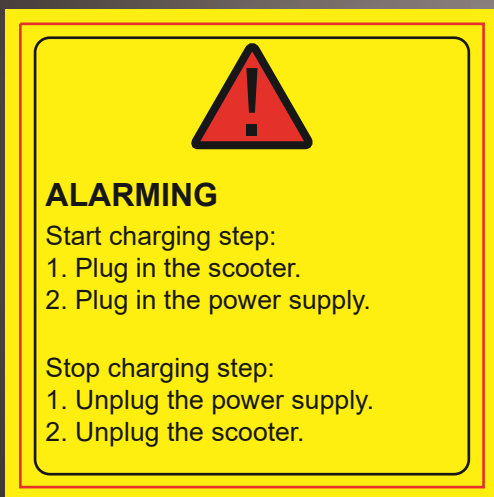

- TRAVEL UP TO 50 KM
- MAXIMUM SPEED OF UP TO 25 KM/H
- SUPPORTS UP 100 KG
- FULLY CHARGES IN UP TO 8 HOURS