

SHURflo®

WATER BOOST SYSTEMS

INLET/OUTLET FITTINGS: 3/8" [9.5 mm] Barb Fittings

PUMP SPECS

Model Number	8025-933-399	8025-933-236
Motor Design	115 VAC 60 Hz permanent magnet; thermally protected and a non-replaceable integral fuse	
Duty Cycle	Intermittent (max. run time 20 min. within one hour)	
Turn-On/Off Pressure	70 PSI [4.8 bar] / 90 PSI [6.2 bar]	40 PSI [2.8 bar] / 60 PSI [4.1 bar]
Max. inlet pressure	30 psi [2 bar]	
Check Valve	Internal (prevent reverse flow)	
Temp. Limits	34 ° - 170 ° F [1.1 ° - 49 ° C]	
Pump materials	EPDM valves, Santoprene diaphragm, Nylon hosing	
TANK SPECS	MINI	MEDIUM
Total Volume (air/liquid)	21 Oz. [0.62 lt]	2 gal [7.6 lt]
*Approx. Draw 90 psi pump	10 Oz. [0.3 lt]	123 Oz. [3.6 lt.]
Down Vol. 60 psi pump	5.6 Oz. [0.17 lt]	68 Oz. [2 lt.]
Bladder Material:	Butyl	Butyl
Housing Material	Glass Filled Nylon	Stainless Steel
		Epoxy coated steel

* Draw down volume varies with tank pre-charge, pump operating pressure and city water pressure. Specs reflect tests at 40 psi [2.7 bar] pre-charge w/20 psi [1.3 bar] city water pressure.

WATER BOOST SYSTEM LIMITED WARRANTY

SHURflo Water Boost Systems are warranted to be free of defects in material and workmanship under normal use, for a period of one (1) year from the date of manufacture, or one (1) year of use, with proof of purchase. This limited warranty will not exceed two (2) years, in any event.

The limited warranty will not apply to Water Boost Systems that were improperly installed, misapplied, or incompatible with fluids or components not manufactured by SHURflo. Water Boost System failure due to foreign debris is not covered under the terms of this limited warranty. SHURflo will not warrant any Water Boost System which is damaged or modified outside the SHURflo factory.

Returns are to be shipped postage prepaid to either service center; SHURflo Garden Grove, CA or Elkhart, IN. SHURflo shall not be liable for freight damage incurred during shipping, package returns carefully.

For complete warranty details consult S/B #1049.



★ ISO Certified Facility



SHURflo reserves the right to update specifications, prices, or make substitutions.



SHURflo ★

5900 Katella Ave.
Cypress, CA 90630
(800) 854-3218 (562) 795-5200
FAX (562) 795-7564

Shipping/UPS: 5900 Katella Ave Bldg. B 264-2169
Cypress, CA 90630

SHURflo East

52748 Park Six Court,
Elkhart, IN 46514-5427
(800) 762-8094
(574) 262-0478

© 2006 Printed in USA

SHURflo Ltd.

Unit 5 Sterling Park, Gatwick Road,
Crawley, West Sussex, RH10 2QT
United Kingdom
+44 1293 424000
FAX +44 1293 421880

INSTALLATION AND OPERATION MANUAL

WARNING: “Risk of electrical shock.” The pump is supplied with a grounding connector and grounding-type attachment plug. To reduce the risk of electrical shock, be certain that it is connected only to a properly grounded, grounding-type receptacle. To prevent electrical shock, disconnect power before initiating any work. In the case of pump failure, the motor housing and/or the pumped fluid may carry high voltage to components normally considered safe.

CAUTION: **DO NOT** adjust the pump pressure switch setting. Switch setting will not significantly alter flow rate or pressure. Improper adjustment may cause severe overload or premature failure, *not covered under warranty.*

CAUTION: **DO NOT** operate the pump at pressures, which cause the motor to exceed the amperes rating indicated on the nameplate. The pump is equipped with thermal breakers to interrupt operation due to excessive heat. Once the temperature of the motor is within proper limits it will automatically reset, and the pump *will start operation without warning. The motor is equipped with an integral non-serviceable fuse. Pumps which have an “open” fuse are not covered under the limited warranty.*

ACCUMULATOR STORAGE/FLOW-RATES

SHURflo Water Boost Systems are for applications when low, fluctuating, or no water pressure exists. The pump and accumulator maintain consistent water pressure to a source (for a given duration) as long as incoming water is sufficient. Depending upon the Water Boost System model, support of up to 4 non-carbonated valves in moderate volume accounts is achievable. The pump pressurizes the accumulator to 60 psi. or 90 psi. [4/6 bar], depending on the pump model. Consult the models flowchart for projected length of flow and/or back-up. Maxi Boost Systems may be used to supply water to a carbonator for back-up, during short periods of insufficient water pressure. The pump is NSF, UL and C-UL listed.

INSTALLATION

CAUTION: **DO NOT** pre-charge the accumulator with CO2. In the event of failure carbonated water will react with brass components in system equipment.

CAUTION: a qualified electrician, in accordance with all local electrical codes should perform all Electrical outlet (receptacle) wiring connections. Circuit protection is dependent on the individual application requirements. Failure to provide proper circuit protection may result in a motor failure, *which is not covered under warranty.*

1. The water booster system is to be installed between the water source and non-carbonated valve(s) or carbonator. Turn off city water supply before installation.
2. Use NSF listed high pressure braided 3/8" ID [9.5 mm] tubing to connect the inlet/outlet ports. Secured all tubing connections with SS, step-less Oetiker® clamps. Cable-tie all tubing securely to prevent kinks or sags that can inhibit performance or cause damage to the pump.

- Remove Accumulator air fitting cap and pre-charge with clean pressurized air, or nitrogen. Tank should be pre-charged **at the minimum required pressure of the application**. Replace air fitting cap securely. In most cases 40 psi [2.7 bar] will provide the required pressure at a typical beverage dispense system. For best pump performance, set accumulator pre-charge pressure at approximately 20 psi [1.3 bar] below max. pump pressure (as stated on the table), and/or at approximately the pump turn-on pressure. For further information consult the factory.
- Turn ON incoming water supply.
- Open the dispenser valves and purge air/water from tubing/accumulator. Close the dispenser valve(s) and let the pump fill the accumulator. The pump may not obtain shut-off pressure if excessive air is trapped within the system. Repeat this step 2-5 times as necessary, before taste testing.

NOTE 1: the accumulator tank pre-charge should be checked bimonthly or as necessary. All outlet water pressure must be depleted prior to checking or recharging.

NOTE 2: if subject to freezing temperature, the pump, tubing and accumulator tank **MUST** be drained of all water.

MEDIUM WATER BOOST SYSTEM
(MEDIUM WB SYSTEM W/ PUMP ON SIDE NOT SHOWN)

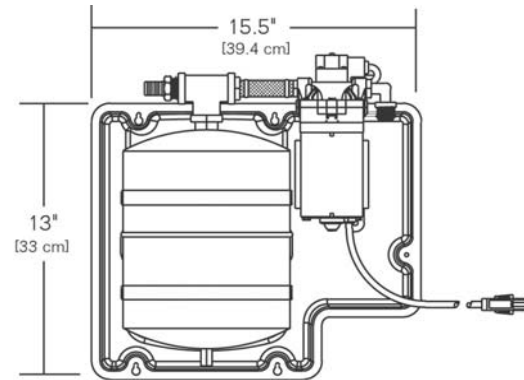

MINI WATER BOOST SYSTEM

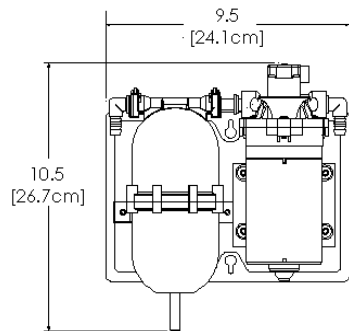

MAXI WATER BOOST SYSTEM

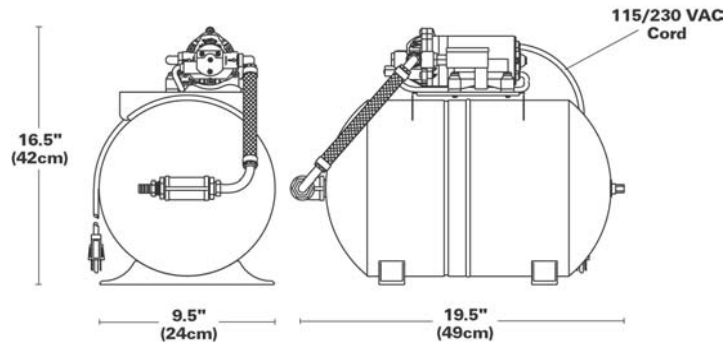

MINI WATER BOOST SYSTEM PERFORMANCE (Units tested with 40 psi pre-charge and 20 psi city water pressure)

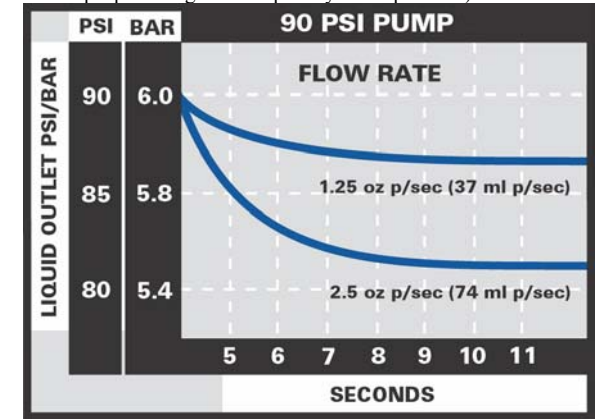
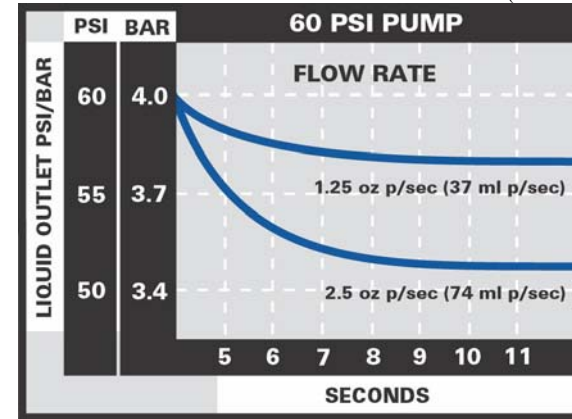

MEDIUM WATER BOOST SYSTEM PERFORMANCE (Units tested with 40 psi pre-charge and 20 psi city water pressure)

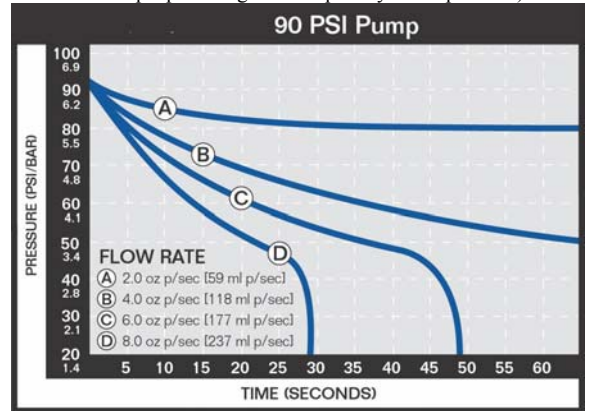
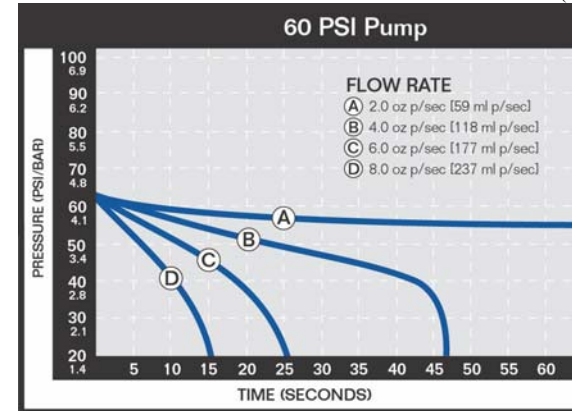

MAXI WATER BOOST SYSTEM PERFORMANCE (Units tested with 40 psi pre-charge and 20 psi city water pressure)

