

CB20-312E Water Filter

High flow, high capacity carbon filter for chloramine and chlorine reduction



APPLICATIONS

Coffee
Fountain

Ice

FEATURES AND BENEFITS

Improves the taste and consistency of beverages and ice by reducing chloramine, chlorine and other off-tastes and odors.

CC1E radial flow cartridge in which the water flows from outside of the cartridge to the center core allowing for greater granular activated carbon (GAC) capacity.

CC3E cartridges fine filter water by reducing sediment and dirt larger than 1/2 micron in size.

Reduces asbestos fibers and cysts such as *Cryptosporidium* and *Giardia*.

High pressure housing includes head with flush valve kit, mounting bracket and bowl. Integral inlet and outlet pressure gauge monitors operation.



CB20-312E System:
CB20-312E Cartridge Kit*:

EV9100-37
EV9105-34

*(1) CC1E replacement cartridge
(2) CC3E replacement cartridges

OPERATIONAL TIPS

Change cartridges on a regular 6 month preventative maintenance program.

Change cartridges when capacity is reached (85,000 gallons) or when flow becomes too slow.

Change cartridges when the difference between the two pressure gauges is greater than or equal to 20 psi.

Service flow rate must not exceed 5.0 gpm

After installing CC1E cartridge, flush at full flow for 5 minutes. Install CC3E cartridges and flush system for 10 minutes.

SPECIFICATIONS

Overall Dimensions:	29.5"H x 25"W x 15.125"D (74.93 x 63.5 x 38.41 cm)
Inlet Connection	1/2"
Outlet Connection	1/2"
Service Flow Rate:	Maximum 5 gpm (19 Lpm)
Rated Capacity:	85,000 Gallons (321,76 L)
Pressure Requirements:	20 - 100 psi (1.4 - 6.9 bar), non-shock
Maximum Temperature:	35 - 100°F (2 - 38°C)
Electrical Connection:	None required
Shipping Weight:	82 lbs. (37.19 kg)
Operating Weight:	90 lbs. (40.82 kg)

CB20-312E Water Filter

EV9100-37

INSTALLATION TIPS

Choose a mounting location suitable to support the full weight of the system when operating.

Never use a saddle valve for connection.

Use 1/2" water line.

Install on cold water lines only

Do not install where unit is exposed to direct sunlight

Allow a minimum of 4" clearance under the filter to facilitate cartridge change

Do not braze/solder fittings into head

The contaminants or other substances removed or reduced by this drinking water system are not necessarily in your water. Do not use with water that is microbiologically unsafe or of unknown quality without adequate disinfection before or after the system. Systems certified for cyst reduction may be used with disinfected water that may contain filterable cysts.

Everpure water treatment systems (excluding replaceable elements) are covered by a limited warranty against defects in material and workmanship for a period of five years after date of purchase. Everpure replaceable elements (filter cartridges and water treatment cartridges) are covered by a limited warranty against defects in material and workmanship for a period of one year after date of purchase. See printed warranty for details. Everpure will provide a copy of the warranty upon request.

Everpure reserves the right to update specifications, change prices, or make substitutions without notice.

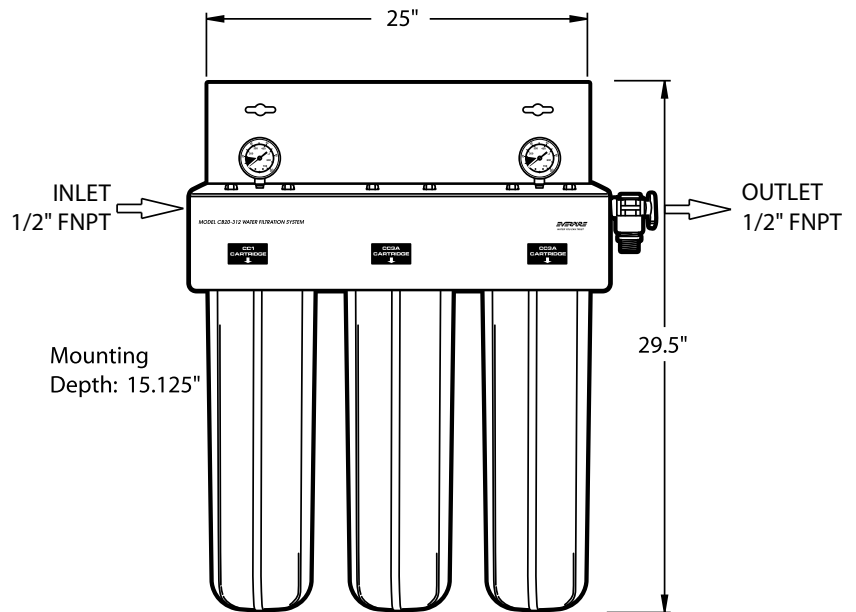

System Tested and Certified by NSF International against NSF/ANSI Standards 42 and 53 for the reduction of:

- Standard No. 42 — Aesthetic Effects
 - Chemical Reduction
 - Taste and Odor
 - Chloramines
 - Chlorine
- Mechanical Filtration
 - Particulate Class 1
- Standard No. 53 — Health Effects
 - Mechanical Filtration
 - Cyst



EV9100-37 CB20-312E JE11



Visit our website at www.everpure.com

Everpure-SHURflo India
Green Boulevard, B-9/A, 7th Floor -
Tower B Sector 62, Noida - 201301
TEL: 91.120.419.9444
FAX: 91.120.419.9400
EMAIL: indiacustomer@pentair.com

Everpure-SHURflo Japan Inc.
Hashimoto MN Bldg. 7F
3-25-1 Hashimoto, Midori-ku
Sagamihara-Shi Kanagawa 252-0143
JAPAN
TEL: 81.(0)42.775.3011
FAX: 81.(0)42.775.3015
EMAIL: info@everpure.co.jp

Everpure-SHURflo China
21F Cloud 9 Plaza, No 1118,
Shanghai, 200052
CHINA
TEL: 86.21.3211.4588
FAX: 86.21.3211.4580
EMAIL: China.Water@Pentair.com

Pentair Filtration Solutions, LLC
World Headquarters-Everpure/SHURflo
North and South America Sales
1040 Muirfield Dr.
Hanover Park, Illinois 60133
USA
TEL: 800.942.1153 (US only)
TEL: 630.307.3000
FAX: 630.307.3030
EMAIL: cseverpure@pentair.com

Everpure-SHURflo Australia
2 Redwood Drive
Notting Hill
Victoria, 3168
AUSTRALIA
TEL: 011.61.39.574.4000
FAX: 011.61.39.562.7237
EMAIL: au.everpure@pentair.com

Everpure-SHURflo Southeast Asia
18 Boon Lay Way
#04-110/111
TradeHub 21, 609966
SINGAPORE
TEL: 65.6795.2213
FAX: 65.6795.2219
EMAIL: cseverpure@pentair.com

Everpure-SHURflo Europe
Pentair Water Belgium bvba
Industriepark Wolfstee
Toekomstlaan
30 B-2200 Herentals, BELGIUM
TEL: +32.(0).14.283.500
FAX: +32.(0).14.283.505
EMAIL: sales@everpure-europe.com