

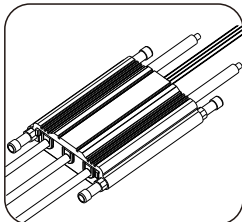

感谢您使用本产品！本产品功率强大，错误的操作可能导致人身伤害和设备损坏，强烈建议您在操作前仔细阅读本说明书并保存，严格遵守规定的操作程序。我们不承担因使用本产品或擅自对产品进行改造所引起的任何责任，包括但不限于对附带损失或间接损失的赔偿责任。我们有权在不通知的情况下变更产品的设计、外观、性能及使用要求。

01 主要特性

- 电调采用功能强大的C8051内核MCU，工作频率最高50MHz；
- 电调性价比极高，精心的电路设计，抗干扰性超强；
- 支持无刷马达最高240K rpm转速；
- 启动方式可设置，油门响应速度快，并具有非常平滑的调速线性，适用于各种模型船；
- 具备多种保护功能，更好保护设备正常使用；设置报警音判断通电后工作情况；
- 低压保护阈值可设置，满足个性化需求；
- 通电安全性能好：接通电源时无论遥控器油门在任何位置不会立即启动马达；
- 内置5A开关BEC，带舵机负载功率大、功耗小；
- 可短时间在水中工作（注：使用后如进水，请将水晾干后再使用）；
- 支持遥控器编程调参，循环菜单设置，操作简单，并兼容所有遥控器操作设置；
- 支持编程卡编程调参（需编程卡）；
- 铝合金水冷散热片配合水冷管，可有效减缓升温；



02 产品规格

型号	持续电流 (散热良好)	瞬间电流 (散热良好)	BEC	锂电池	重量 (供参考)	尺寸 (不含水冷管, 供参考)
O' HARA-50A	50A	70A	5.5V, 5A 开关模式	2-6S	90g	57x49x18mm
O' HARA-70A	70A	90A	5.5V, 5A 开关模式	2-6S	101g	57x49x18mm
O' HARA-90A	90A	110A	5.5V, 5A 开关模式	2-6S	102g	57x49x18mm
O' HARA-120A	120A	140A	5.5V, 5A 开关模式	2-6S	155g	76x56x25mm
O' HARA-150A	150A	170A	5.5V, 5A 开关模式	2-6S	169g	76x56x25mm

03 连线示意图

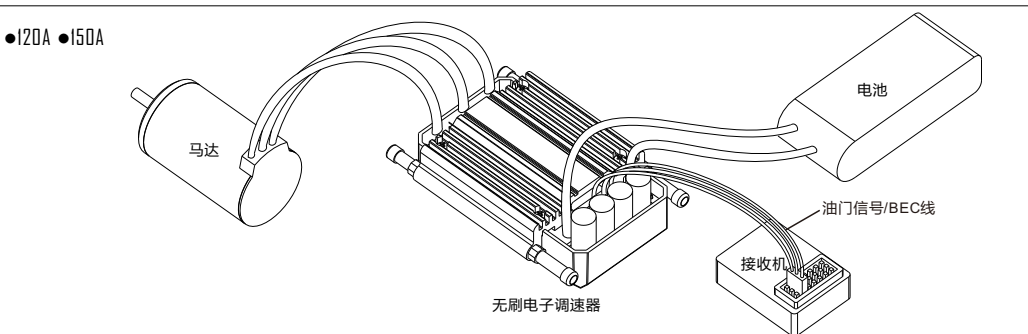
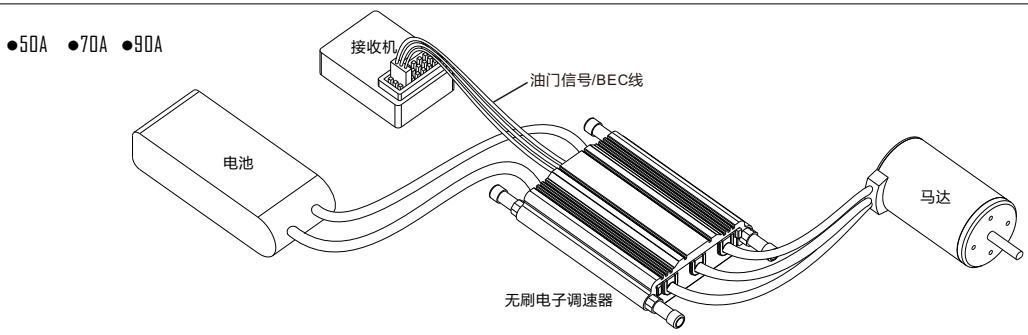

1. 油门信号/BEC线（黑白红）：插入接收机油门通道。其中白线为传输信号，红线和黑线分别为内部BEC的输出线和地线；
2. 每种规格的产品外观有差异，图片为代表型号仅供参考，以实物为准；
3. 为避免短路和漏电，请保证连接处绝缘良好。

04 保护功能

上电安全保护	上电后如果油门不在待命零点位置，马达将会发出急促的短鸣音进行报警，直到检测到待命零点油门以后方可启动电机。
低压保护	如果电压低于低压保护阈值，那么ESC将自动降低输出功率进行保护，运行几秒后马达停止转动，需将油门回中归零后方可重新启动，以上动作可以重复操作之。
启动保护	当加大油门时，三秒内未能正常启动马达，电调将会关闭动力输出，油门需再次置于零点后才能重新启动马达。（出现这种情况的原因可能有：电调和马达连接接触不良或有断开、螺旋桨被其他物体阻挡等）。
温度保护	当电调工作温度超过100度后，ESC将自动降低输出功率（等效油门范围将被限制在40%左右）进行保护，保证马达留有一定动力以确保返回。当温度下降到低于80度以后，电调将恢复到正常运行模式。
油门信号丢失保护	马达运行时，如果ESC检测到油门信号丢失将关闭输出，避免因电机继续高速转动而造成更大的损失。如果油门信号恢复，ESC可以立即恢复相应的功率输出。

报警音：设计可通过电机听见的报警音，供使用者判断通电后的异常情况；
1. 未检测到油门信号报警音：上电时，当电调未检测到油门信号时，会发出如下警示：“滴-滴-滴-”（每声之间的间隔为2秒）；

2. 油门未归零（油门未置于零点位置报警音）：上电时，当油门未置于零点位置，会发出如下警示：“滴-滴-滴-滴-”（很急促的单短音鸣叫）；

3. 电压超限报警音：上电时，当电调检测到电池电压高于额定工作电压时，会发出如下警示：“滴滴-滴滴-滴滴-”（每声之间的间隔为1.5秒）；

4. 油门行程过小报警音：当所设定油门总行程过窄时（电调设计时，要求油门总行程不得小于三格油门），会发出警示表明本次行程设定无效，需要重新设定。警示方式：“滴-滴-滴-滴-”（持续2秒后停止）；

05 操作说明

- 建议用户做额外防水以获得更加防水效果；使用后如进水，请将水晾干后再使用，避免损坏产品；
- 遥控器有差异，某些接收机会产生信号（遥控器未开启时），为避免伤害，任何时候请先开遥控器，再将ESC上电；
- 第一次使用时建议先设置油门行程。根据不同的遥控器设置最佳油门行程，电调才能够通过遥控器的整个油门行程来获取最平滑的油门线性，目的是让电调获取并记忆遥控器的油门输出信号，此操作只需要进行一次，更换遥控器时需重复此操作步骤；

1 油门行程设定

注：以下均为带中点位（零点）的枪控或者板控的示意图，推荐用于单向和双向运行模式；另外单向运行时也可选择不带中点位的板控。

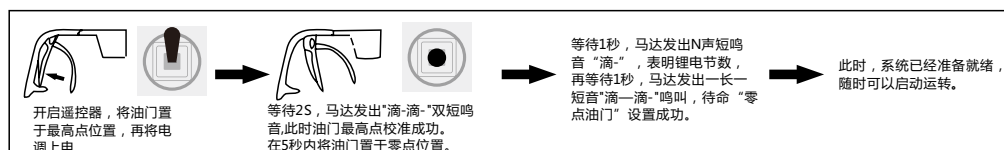

2 正常工作模式

注：以下均为带中点位（零点）的枪控或者板控的示意图，推荐用于单向和双向运行模式；另外单向运行时也可选择不带中点位的板控。

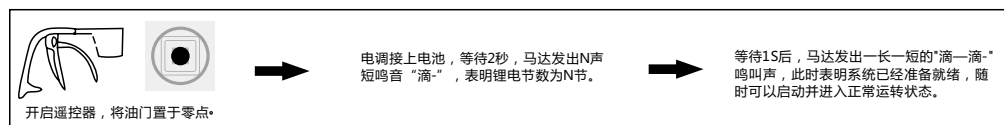

3 参数编程设定

方式1：通过编程卡进行参数编程（推荐）

- 使用方法请参考编程卡使用说明书；
 - 需单独购买编程卡，型号BCK-S006-A1A1；
- 用编程卡对电调进行设置是最理想方便的选择，只要将电调信号线插入编程卡，选择您想要更改的项目，按【OK】VALUE窗口显示“S”即可。如要恢复出厂默认的选项先按【RESET】再按【OK】即可。

方式2：通过遥控器进行参数编程设定

ESC可以通过遥控器进行参数编程设定。

开启遥控器，将油门置于最高点

电调接上电池，等待2S，马达发出“滴-滴-”双短鸣音，继续等待5S，马达鸣叫“12321”特殊提示音，表明已经进入编程模式。

设定项目
进入编程模式后，会听到以下鸣音按顺序循环鸣叫，

		12321
1 运行模式	1短音	滴-
2 电机运转方向	2短音	滴-滴-
3 低压保护阈值	3短音	滴-滴-滴-
4 启动加速度	4短音	滴-滴-滴-滴-
5 电机进角	1长音	滴--
6 恢复出厂设置	1长音1短音	滴-滴-
7 退出	1长音2短音	滴-滴-滴-

注：一个长音“滴--”相当于5声短音“滴”；一长一短“滴-滴-”表示第6项。

当马达鸣叫“退出”选项鸣音后的3秒内将油门置于零点位置，马达发出“765765”鸣音，则退出设定。

项目参数值

在马达发出某组鸣音后，3秒内将油门置于零点，则进入该设定项目，进入项目参数值设定时，马达会循环鸣叫参数值的指示音（见下表）

在鸣叫某个提示音后将油门置于最高点位置，则选择该提示音所对应的设定值，接着马达鸣叫特殊提示音“1212”，表示该参数值已被保存。如果还要设定其它选项，则继续等待，退回上一步骤，再选择其它设定项目。

项目	鸣叫音							
	1短音	2短音	3短音	4短音	1长音	1长1短	1长2短	1长3短
1.运行模式	单向	双向						
2.电机运转方向	正常	反向						
3.低压保护阈值	无保护	2.6V	2.8V	3.0V	3.2V	3.4V		
4.启动加速度	1级	2级	3级	4级	5级			
5.电机进角	0°	3.75°	7.5°	11.25°	15°	18.75°	22.5°	26.25°

阴影部分为出厂默认值

此时如果不想再设定其它选项，则在3秒内将油门置于零点位置，接着马达鸣叫特殊提示音“765765”，即可快速退出；或者断电以退出编程设定模式。

编程参数值说明

- 1. 运行模式：**
 [1] 单向：只能前进，不能倒退，油门反向时无效。
 [2] 双向：有倒退功能，当油门从正向推到反向区域时，在电机停止运转后船模会立即倒退（反向最大油门的转速大约是正向的25%）。
- 2. 电机转向：**
 [1] 正常：电机当前的转向
 [2] 反转：改变电机当前的转向
 此功能旨在方便用户无需更换电机线即可实现马达变更转向。
- 3. 低压保护阈值：**
 [1] 无保护；[2] 2.6V；[3] 2.8V；[4] 3.0V；[5] 3.2V；[6] 3.4V；
 该功能选项主要针对锂电池组设计，当电池电压达到设定的保护阈值时，电调将进行保护；对于Ni-xx电池组建议选择无保护选项。
- 4. 启动加速度：**
 [1] 1级；[2] 2级；[3] 3级；[4] 4级；[5] 5级；
 提供带有5级线性油门响应的快速加速启动，级数越大加速越快。
- 5. 进角设置：**
 [1] 0°；[2] 3.75°；[3] 7.5°；[4] 11.25°；[5] 15°；[6] 18.75°；[7] 22.5°；[8] 26.25°；
 大多数情况下，15°进角适用于所有类型的马达，但为了提高效率，我们建议对2级马达使用低进角设置（一般的内转子），6级和6级以上（一般的外转子）马达使用高进角。对于要求较高转速的马达，可以设定高进角。某些马达需要特殊的进角设置，如无无法确定我们建议您采用马达制造商推荐的进角设置或使用15°进角设置。
 注：马达的进角设置修改后，请先在岸上进行调试成功后再入水试船。
- 6. 恢复出厂设置：**
 当电机鸣叫“恢复出厂设置”的声音后，3秒内将油门置于零点位置，此选项没有下一级子菜单，马达鸣叫特殊提示音“765765”后即恢复出厂设置。
- 7. 退出：**
 当电机鸣叫“退出”的声音后，3秒内将油门置于零点位置，接着马达鸣叫特殊提示音“765765”，即可退出编程。

06 故障快速处理

故障现象	可能原因	解决办法
上电后，马达不工作，并未发出任何音乐声，伺服系统也未接通。	电池组与ESC之间接触不良，电源没有接通。	重新清理插头或更换插头，检查并确认接线极性正确。
	焊接不牢固，容易造成接触不良。	再次焊接连接线。
	电池电压不足。	检查电池组，用符合规格满电的电池组替换。
上电后，ESC有自动检测电池节数声音，但马达不能启动。	ESC进水、损坏或者有其他质量问题。	清理ESC上水并晾干后再尝试；更换ESC。
	ESC没有设置油门行程。	重新进行油门行程设置。
ESC工作，但马达不工作，未发出音乐声。	ESC与马达之间接触不良，或焊接不牢。	检查连接器终端或替换连接器或再次焊接马达接线。
	马达不良。	更换马达。
ESC上电后，马达不工作，发出报警音。“滴滴-滴滴-滴滴-”（每声之间的间隔为1.5秒）	电池电压超限。	检查电池组电压是否在ESC工作范围内。
上电后，马达不工作但发出报警音。（滴-滴-滴-滴-，每声之间的间隔为2秒）	接收机油门信号无输出。	1. 检查并确认信号线与接收机油门通道是否连接正确； 2. 检查发射器和接收机，确认有信号输出。
上电后，马达不工作，发出持续报警音。（滴-滴-滴-滴-滴-，很急促的单短音鸣叫）	油门摇杆未放置最小位置上。	将油门摇杆移至“零点”位置或者重新设置油门行程。
上电后，马达不工作，ESC发出两声长响之后，有两声短促的滴滴响。	油门通道正反被错置，导致ESC进入编程模式。	参考遥控器的说明书，调整油门通道正反设置。
马达反向运行。	马达与ESC连接线顺序错误。	1. 将ESC与马达之间三条连接线中的任意两条调换。 2. 直接用编程卡或遥控器编程来改变马达转向设置，改变方向。
	电池电压低于设定的低压保护电压阈值。	1. 请及时驶回，并检查电池电压，并对电池充电； 2. 在遥控器的可控范围内注意遥控器电池电压，若电压降低较多，需及时驶回。
运行过程中，马达中途停转。	油门信号丢失。	1. 检查遥控器是否操作得当。 2. 检查遥控器与接收机配合是否正确。 3. 检查信号线是否有松动或脱落。 4. 使用环境中极强烈的电磁干扰，尝试重新上电启动以恢复正常工作，若该问题反复出现，说明外部干扰过于强烈，请更换场地。
	接线接触不良。	检查电池组插头，电池输出线和马达连接线是否连接可靠。



Thank you for using our product. Any improper operation may cause personal injury or damage the product and relevant equipments. This high power system for RC model can be dangerous, we strongly recommend reading the user manual carefully and completely. We will not assume any responsibility for any losses caused by unauthorized modifications to our product. We have the right to change the design, appearance, performance and usage requirements of the product without notice.

01 Main features

- High performance MCU ,which with 8-bit C8051 core and working frequency up to 50Mhz.
- High cost performance of ESC, elaborate circuit design and strong anti-interference.
- Support brushless motor up to 240k erpm;
- The starting mode can be set, throttle response fast, and the speed regulation linearity is very stable. which is suitable for various RC boat.
- Multiple protection make the equipments safety. Beeping alarm can indicate working condition.
- Low voltage protection threshold can be set to meet personalized needs.
- Good safety performance when power on, when power on, the motor will not be started immediately regardless of the throttle position of the remote controller.
- Built in 5A switch BEC, It can carry the steering gear with high load power.
- ESC can work in water for a short time (Note: if there is water after use, please dry the water before use)
- Cycle programming menu for easy operation. Compatible with all kinds of remote controls' programming.
- Support programming via programming card (extra Programming Card needed).
- Water cooled aluminum heat sink can effectively slow down the temperature rise.

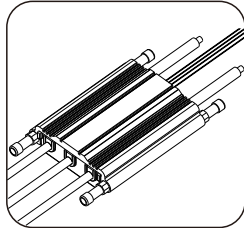

02 Specifications

Model	Con. Current (Good heat dissipation)	Burst Current (Good heat dissipation)	BEC	LiPo	Weight (For reference)	Size (For reference)
O' HARA-50A	50A	70A	5.5V, 5A Switch BEC	2-6S	90g	57x49x18mm
O' HARA-70A	70A	90A	5.5V, 5A Switch BEC	2-6S	101g	57x49x18mm
O' HARA-90A	90A	110A	5.5V, 5A Switch BEC	2-6S	102g	57x49x18mm
O' HARA-120A	120A	140A	5.5V, 5A Switch BEC	2-6S	155g	76x56x25mm
O' HARA-150A	150A	170A	5.5V, 5A Switch BEC	2-6S	169g	76x56x25mm

03 Wiring Diagram

•50A •70A •90A

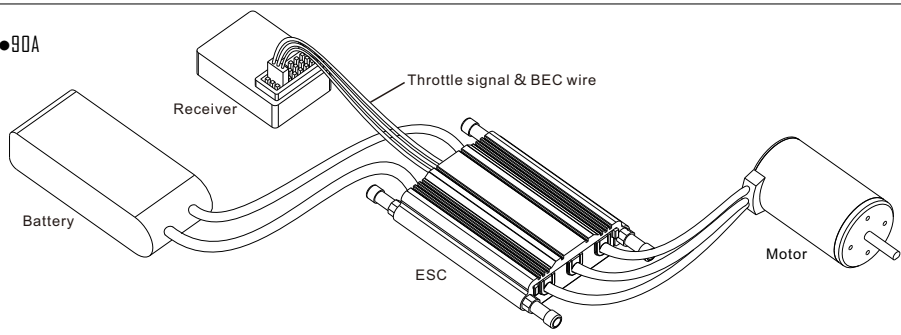

•120A •150A

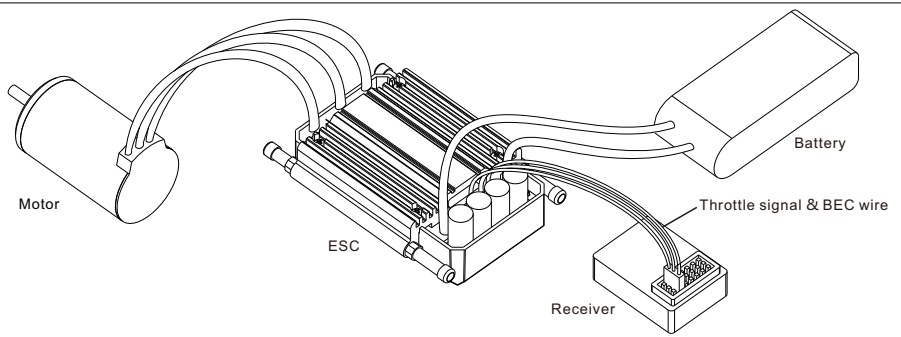

1. Throttle signal & BEC wire : Plug it into the throttle channel on the receiver, the white wire is for transmitting throttle signal, the red and black wires are the BEC output wire and ground wire.
2. There are differences in the appearance of the products, the pictures are the representative models for reference only.
3. Please ensure all solder joints are insulated with heat shrink where necessary.

04 Protections

Power on safety protection	If the throttle is not in the neutral position after power on, the motor will emit alarm. The motor can not be started until the neutral position throttle is detected.
Low voltage protection	If the voltage is lower than the set low-voltage protection threshold, ESC will automatically reduce the output power for protection. After running for several seconds, the motor will stops, it can restart when the throttle returned to neutral position. The above operation can be repeated.
Start-up protection	ESC will cut off output if it fails to start the motor within 3 seconds by accelerating throttle. you need to move the throttle back to the neutral position and restart the motor. (The possible causes : Bad connection or disconnection between ESC & motor , propellers are blocked, etc)
Over heat protection	When ESC temperature is higher than 100 °C, it will reduce output power (throttle will be limited below 40%) for protection, make the motor has enough power for return , when the temperature drops to 80°C , ESC will return to normal working.
Throttle signal loss protection	ESC detects the loss of throttle signal during motor running, it will cut off output immediately to avoid an even greater loss caused by the continuous high speed rotation of motor. ESC will return the corresponding output after the signal is restored.

Alarm tone: (To judge the abnormal cases via alarm tone)

1. Alarm of throttle signal is not detected:

ESC detects no signal when power on, motor will emit the alarm tone "B-, B-, B-"(emits every 2 seconds).

2. Alarm of throttle not in the neutral position:

Throttle not in the neutral position, motor will emit "B-B-B-B-" (urgent short tone).

3. Alarm of voltage out of range:

The ESC detects that the battery voltage is higher than rated voltage when power on, , motor will emit"B-B-, B-B-, B-B-"(emits every 1.5 seconds).

4. Alarm of narrower throttle range:

when throttle range is set too narrow, motor emits "B-B-B-" (urgent short tone, stop after 2 seconds). You must set throttle range again.

05 Operation instruction



- It is suggested that users should do extra waterproof to get better waterproof effect. If there is water on ESC after use, please dry the water before use ,in order to avoid damaging the product).
- There is different with remote controls , some receivers generate signals when the remote control is not turned on. To avoid injury, please turn on the remote control first and then power on the ESC at any time.
- It is recommended to calibrate throttle range for the first time, to get the most stable throttle linearity for different remote controls , and let the ESC acquire and memorize the throttle output signal of the remote control. This operation only needs to be carried out once, and needs to be repeated when replacing the remote control.

1 Throttle Range calibration

Note: the following are the diagrams of pistol or stick remote control with neutral position (zero point), which are recommended for Unidirectional and Bidirectional running modes; in addition, stick remote control without neutral position can be selected for unidirectional operation.

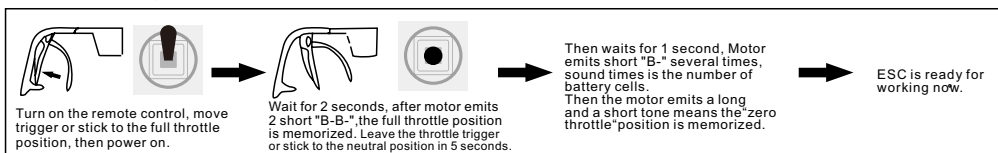

2 Normal start-up

Note: the following are the diagrams of pistol or stick remote control with neutral position (zero point), which are recommended for Unidirectional and Bidirectional running modes; in addition, stick remote control without neutral position can be selected for unidirectional operation.

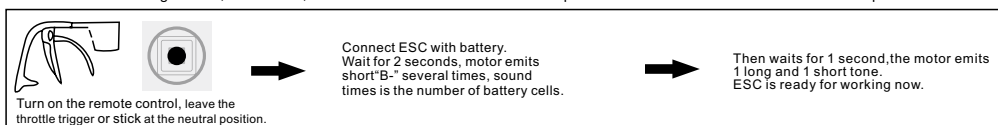

3 Programming

Option 1 : Via Programming Card (recommended)

- Please refer to the user manual of Apisqueen Programming Card;
- Programming Card needs to be purchased separately. Model: BCK-S006-A1A1.

It's the easiest way to use programming card. Operation is as following: plug the signal wire into the programming card , select the parameter that you want (see in the chart below), press [OK] , after VALUE screen displaying "S" , this parameter sets successfully . If want to reset the option to factory setting, please press [RESET] , then press [OK] .

(Please see the instruction of programming card for more detail)

Option 2 : Via Remote Control

ESC parameters can be programmed by remote control.

Turn on the remote control, move trigger or stick to the full throttle position, then power on.

Wait for 2 seconds, motor emits 2 short "B-B-". Then still keep and wait for 5 seconds, motor emits special tone " 12321", it has entered programming mode.

Select Items
After entering programming mode, you will hear groups tone which emits in a loop as following sequence .

			12321
1	Running Mode	1short	Beep-
2	Motor running direction	2short	Beep-Beep-
3	Low Voltage Threshold	3short	Beep-Beep-Beep-
4	Start Acceleration	4short	Beep-Beep-Beep-Beep-
5	Motor Timing	1long	Beep--
6	Restore factory default	1long&1short	Beep--Beep-
7	Exit	1long&2short	Beep--Beep-Beep-

Note: Usually, 1 long tone "Beep--" equals to 5 short tone "beep-", for example: 1 long tone "Beep--" and 1 short tone "beep-" equals to 6.

When motor emits "Exit" tone, move throttle to neutral position (zero point) in 3 seconds, then motor emits special tone " 765765", it will exit the programming mode.

Item parameter

After motor emits a Item tone ,move the trigger or stick to the neutral position, then will enters this item, and motor will emits the parameter tone in a loop Please see the table below)

Move the trigger or stick to the full throttle position after a certain tone that the parameter you want, the parameter is selected, then motor emits special tone " 1212", this parameter will be stored. Just keep and wait if you still want select other item, it will go back to the Level 1 menu to select item, the operate method is the same.

If don't want select other parameter, move the trigger or stick to the neutral position in 3 seconds, then motor emits special tone " 765765", it will exit the programming mode. Or power off, it will exit the programming mode.

Item	Prompt tone							
	1	2	3	4	5	6	7	8
1. Running Mode	1short	2short	3short	4short	1long	1long&1short	1long&2short	1long&3short
2. Motor Running Direction	Unidirectional	Bidirectional						
3. Low Voltage Threshold	No	2.6V	2.8V	3.0V	3.2V	3.4V		
4. Start Acceleration	Level 1	Level 2	Level 3	Level 4	Level 5			
5. Motor Timing	0°	3.75°	7.5°	11.25°	15°	18.75°	22.5°	26.25°

Shadow parts are factory default value.

Parameter description

1. Running Mode:

[1]Unidirectional: It can only move forward, no effect when move the trigger or stick from forward to reverse.

[2]Bidirectional: When move the trigger or stick from forward to reverse, the motor will immediately reverse after it stops running. (The speed of the reverse maximum throttle is about 25% of the forward speed)

2. Motor Running Direction:

[1]Normal : Default motor rotation direction ;

[2]Reversed : Change the direction of rotation of the motor.

3. Low Voltage Threshold:

[1]No [2]2.6V [3]2.8V [4]3.0V [5]3.2V [6]3.4V

In order to keep the battery at a safe minimum voltage (for LiPo batteries). The ESC monitors the battery voltage all the time, when the voltage goes below the threshold, ESC will be protected immediately. Please set to "Disabled" if you're using NiMH batteries.

4. Start Acceleration:

[1]Level 1 [2]Level 2 [3]Level 3 [4]Level 4 [5]Level 5

It can be adjustable from 1 to 5, set a high value to have a quick start-up response, but requires high discharge capacity of the battery.

5. Motor Timing:

[1]0° [2]3.75° [3]7.5° [4]11.25° [5]15° [6]18.75° [7]22.5° [8]26.25°

As usual, 15° applies to all the outer rotor motors, but for improving efficiency , recommend that set low timing for 2 poles motor (most inner rotor motors), set high timing for 6 poles and high poles motors (most outer rotor motors). If need high speed motor, you can set high timing. Some motors should set special timing, if not sure, you'd better to set timing as motor manufacturer recommended, or set 15°.

Note: After changing timing, please test on the ground before running.

6. Restore factory default:

When the beeping indicates the "Restore default settings", move the throttle trigger or stick to neutral position in 3 seconds. There is no sub-menu under this mode, then motor emits special tone " 765765" which means default settings are restored.

7. Exit:

When the beeping indicates the "Exit" mode, move the trigger or stick to the neutral position in 3 seconds, then motor emits special tone " 765765", it will exit the programming mode.

06 Trouble Shooting

Troubles	Possible causes	Solutions
After power on, the motor doesn't work and doesn't emit any sound.	Bad connection between ESC and battery.	Clean the connectors or replace them, check and confirm that the polarity is correct..
	Bad soldering cause bad contact.	Solder the wires again.
	Low voltage of the battery.	Check battery voltage, use full-charged battery.
	Water got in, damage or other quality problems with ESC.	Clean up and dry the water of ESC , try again ; Replace ESC .
After power on, ESC emits the sound of battery cells, but motor doesn't work.	ESC doesn't calibrate throttle range.	Calibrate throttle range again.
After power on, ESC works ,but the motor doesn't work and doesn't emit any sound.	Bad connection between ESC and motor, or bad soldering.	Check the connectors or replace the connectors or solder the motor wire again.
	Bad motor.	Change motor.
After power on , the motor doesn't run and emits warning tone"B-B-, B-B-, B-B-"(emits every 1.5 seconds)	Battery voltage out of range	Check the battery voltage is within the range of ESC.
After powering up, motor doesn't work and emits warning tone"B-, B-, B-"(emits every 2 seconds).	No throttle signal from receiver.	1. Check if right connection between signal wire and receiver throttle channel. 2. Check remote control and receiver, make sure there are signal outputs.
After power on, the motor doesn't work and emits continuous warning tone"B-B-B-B-B-"(urgent short tone).	Throttle trigger or stick doesn't in the neutral position (zero position).	Move the throttle trigger or stick to the neutral position, or Calibrate throttle range again.
After power on, the motor doesn't work. Motor emits 2 long "B-" and 2 short "B-".	The positive and negative of throttle channel is wrong. So ESC enters programming mode.	Refer to the user instruction of transmitter, adjust the setting of throttle channel.
Motor rotates in the opposite direction.	The wrong sequence of connection wires between motor and ESC.	1. Exchange random 2 of the 3 connection wires between ESC and motor. 2. Change motor rotation direction via Programming Card or Remote Control.
	Battery voltage is lower than low-voltage protection threshold.	1. Drive back in time, check the battery voltage and charge the battery; 2. Pay attention to the voltage of the remote control within the controllable range, it needs to drive back in time if the voltage is low .
Motor stops during running	Loss throttle signal	1. Check if the remote control operate correctly. 2. Check if remote control match with the receiver. 3. Check if the signal wire is loose or falling off. 4. Strong electromagnetic interference around the environment, try to turn off and power up again, to see if it recovers normal work, if the problem come up again and again, please change to another field.
	Bad connection between wires	Check the connectors of battery pack, battery wires and motor wires connections are good.