

TECHNICAL SPECIFICATIONS

VOLTS		120
AMPS		12.5
WATTS		1465
HEATER	HIGH	1465 watts
	LOW	750 watts
NO HEATER		19 watts
LAMPS	TYPE	LED
	WATTS	
	TOTAL WATTS	41 watts
ROTOR MOTOR		2 at 5 watts
HEIGHT,WIDTH,DEPTH		33" x 43 1/4" x 13 3/4"
GLASS VIEWING OPENING		22" X 39 5/8"
GLASS SIZE		22" X 39 5/8"
SHIPPING SIZE		35 1/4" x 47 1/2" x 15 5/8"
SHIPPING WEIGHT		125.7 lbs
	UNIT	109.6 lbs
	GLASS FRONT	Included
PLUG LOCATION		Left Side
CORD LENGTH		76"
APPROX. HEATING AREA		400 sq ft

Amantii

SERIES	MODEL		REV
TRU VIEW	40-TRV-XL-XT		1
SCALE 1"=1'-0"	DATE: 9/19/2019	SHEET 1 OF 1	

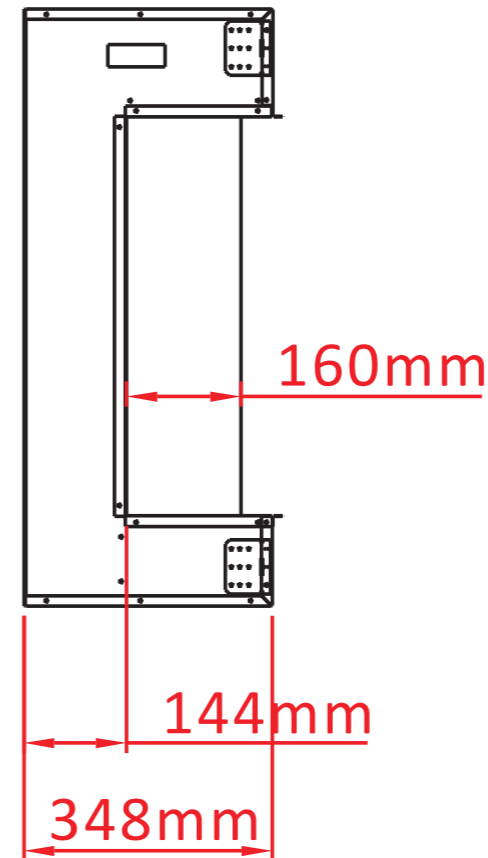
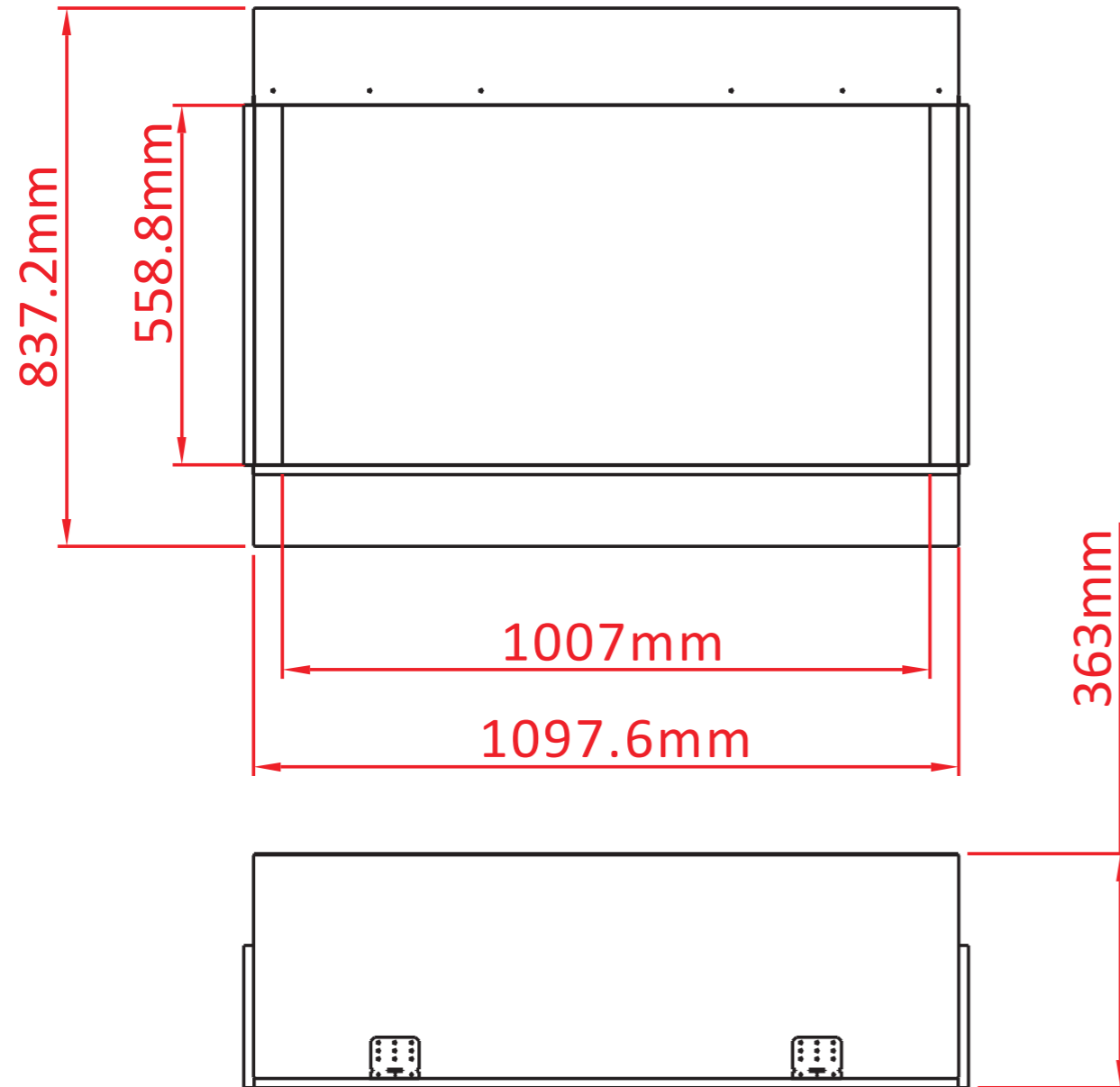

TECHNICAL SPECIFICATIONS

VOLTS		120
AMPS		12.5
WATTS		1465
HEATER	HIGH	1465 watts
	LOW	750 watts
NO HEATER		19 watts
LAMPS	TYPE	LED
	WATTS	
	TOTAL WATTS	41 watts
ROTOR MOTOR		2 at 5 watts
HEIGHT,WIDTH,DEPTH		83.7 x 109.8 x 34.8 cm
GLASS VIEWING OPENING		55.9 X 100.7 cm
GLASS SIZE		55.9 X 100.7 cm
SHIPPING SIZE		89.6 x 120.8 x 39.8 cm
SHIPPING WEIGHT		57 Kgs
	UNIT	49.7 Kgs
	GLASS FRONT	Included
PLUG LOCATION		Left Side
CORD LENGTH		193 cm
APPROX. HEATING AREA		37 sqm

Amantii

SERIES	MODEL		REV
TRU VIEW	40-TRV-XL-XT		1
SCALE 1:12	DATE: 9/19/2019	SHEET 1 OF 1	

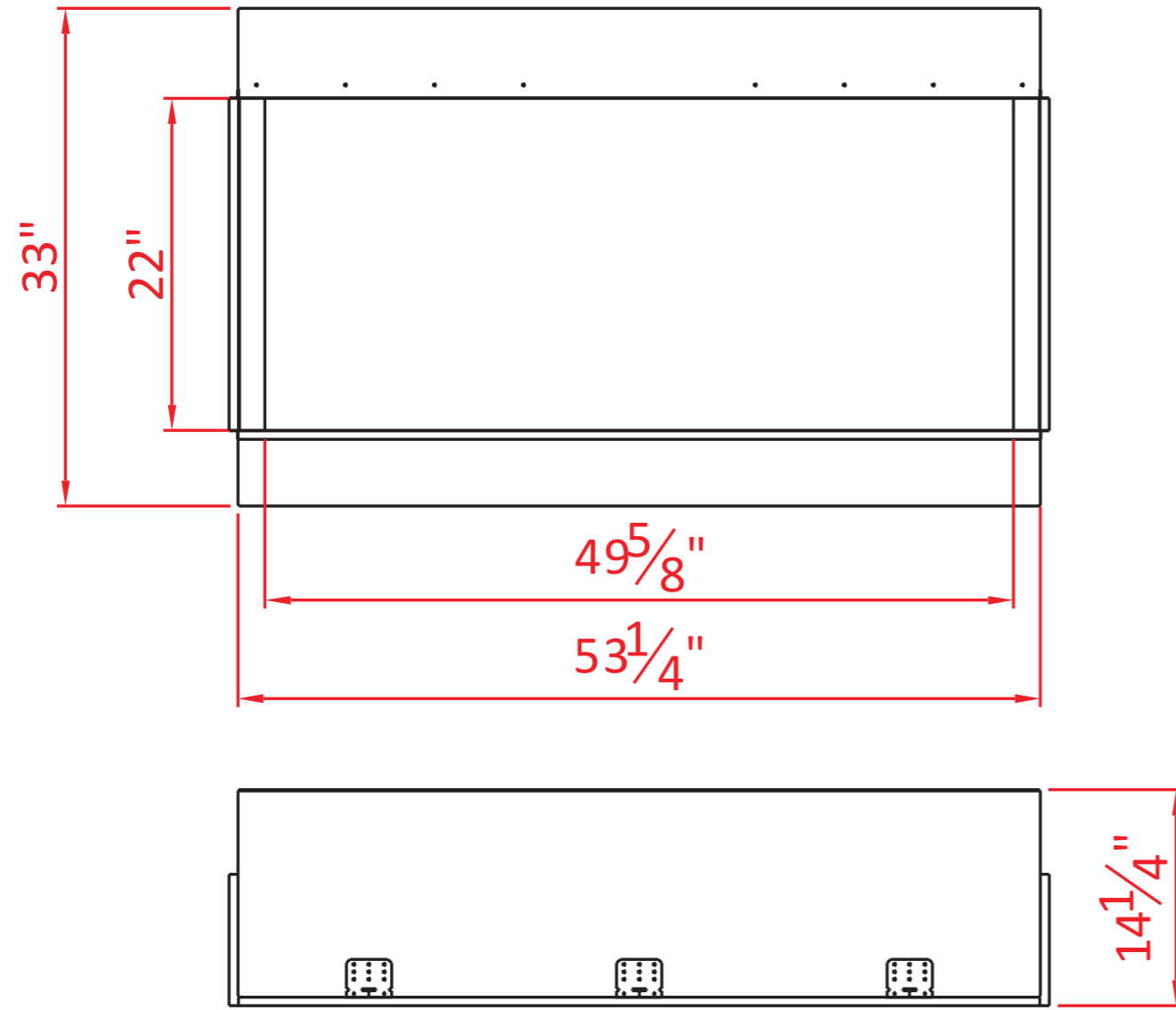

TECHNICAL SPECIFICATIONS

VOLTS	120	
AMPS	12.5	
WATTS	1465	
HEATER	HIGH	1465 watts
	LOW	750 watts
NO HEATER	19 watts	
LAMPS	TYPE	LED
	WATTS	
	TOTAL WATTS	48 watts
ROTOR MOTOR	2 at 5 watts	
HEIGHT,WIDTH,DEPTH	33" x 53 1/4" x 13 3/4"	
GLASS VIEWING OPENING	22" X 49 5/8"	
GLASS SIZE	22" X 49 5/8"	
SHIPPING SIZE	35 1/4" x 57 1/2" x 15 5/8"	
SHIPPING WEIGHT	UNIT	147.7 lbs
	GLASS FRONT	129.6 lbs
PLUG LOCATION	Left Side	
CORD LENGTH	76"	
APPROX. HEATING AREA	400 sq ft	



SERIES	MODEL		REV
TRU VIEW	50-TRV-XL-XT		1
SCALE 1"=1'-0"	DATE: 9/19/2019	SHEET 1 OF 1	

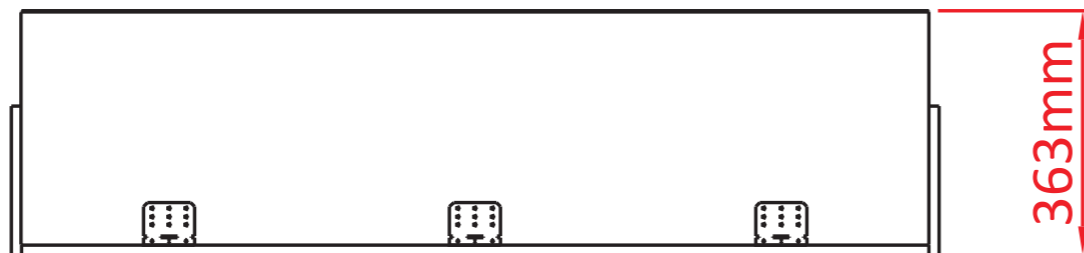
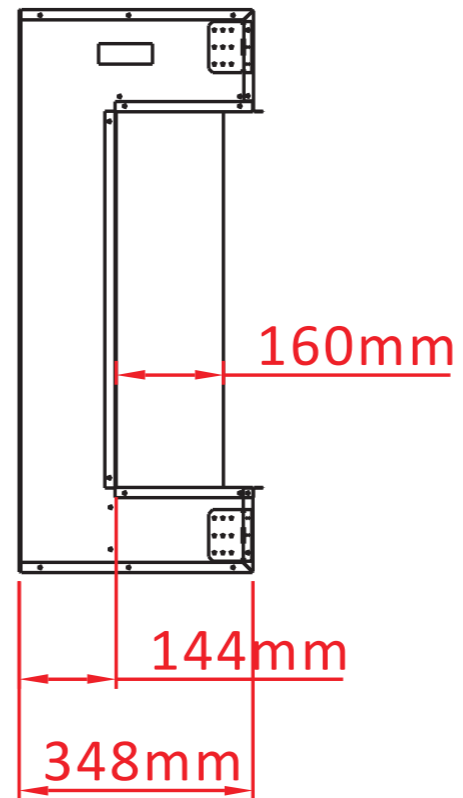
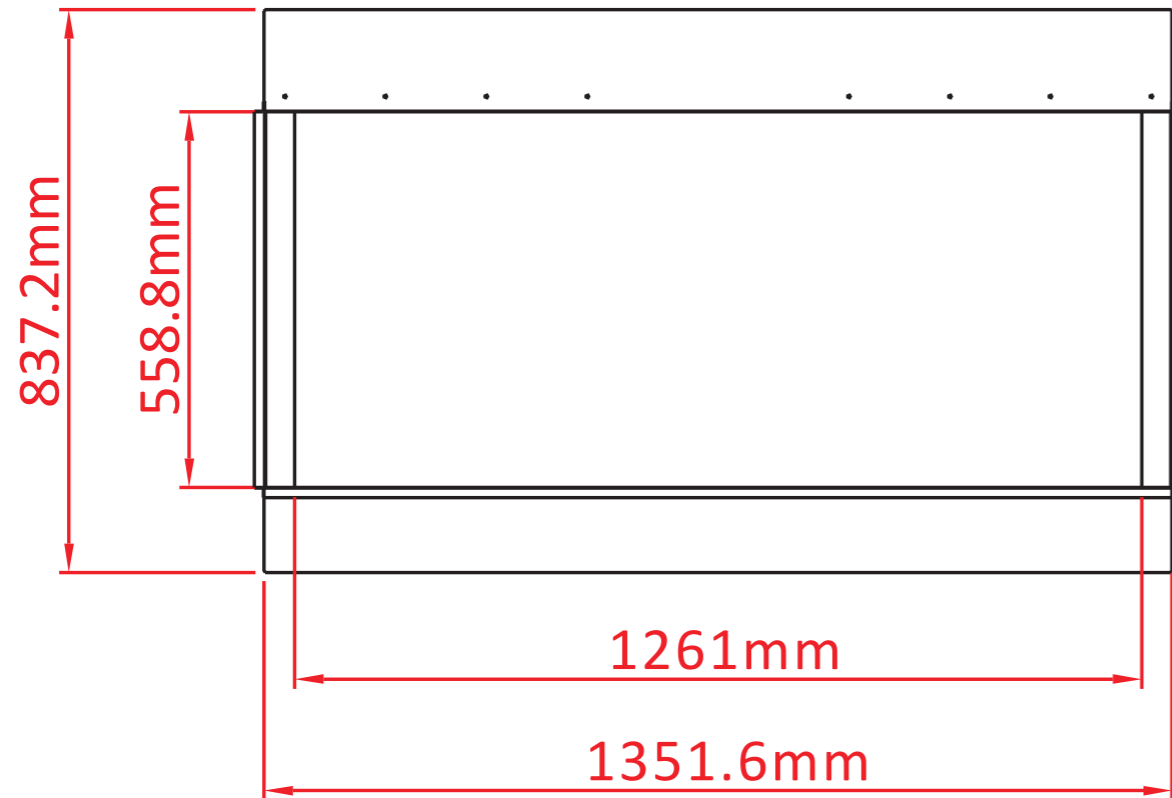

TECHNICAL SPECIFICATIONS

VOLTS		120
AMPS		12.5
WATTS		1465
HEATER	HIGH	1465 watts
	LOW	750 watts
NO HEATER		19 watts
LAMPS	TYPE	LED
	WATTS	
	TOTAL WATTS	48 watts
ROTOR MOTOR		2 at 5 watts
HEIGHT,WIDTH,DEPTH		83.7 x 135.2 x 34.8 cm
GLASS VIEWING OPENING		55.9 X 126.1 cm
GLASS SIZE		55.9 X 126.1 cm
SHIPPING SIZE		89.6 x 146.2 x 39.8 cm
SHIPPING WEIGHT		67 Kgs
	UNIT	58.8 Kgs
	GLASS FRONT	Included
PLUG LOCATION		Left Side
CORD LENGTH		193 cm
APPROX. HEATING AREA		37 sqm

Amantii

SERIES TRU VIEW	MODEL 50-TRV-XL-XT		REV 1
SCALE 1:12	DATE: 9/19/2019		SHEET 1 OF 1

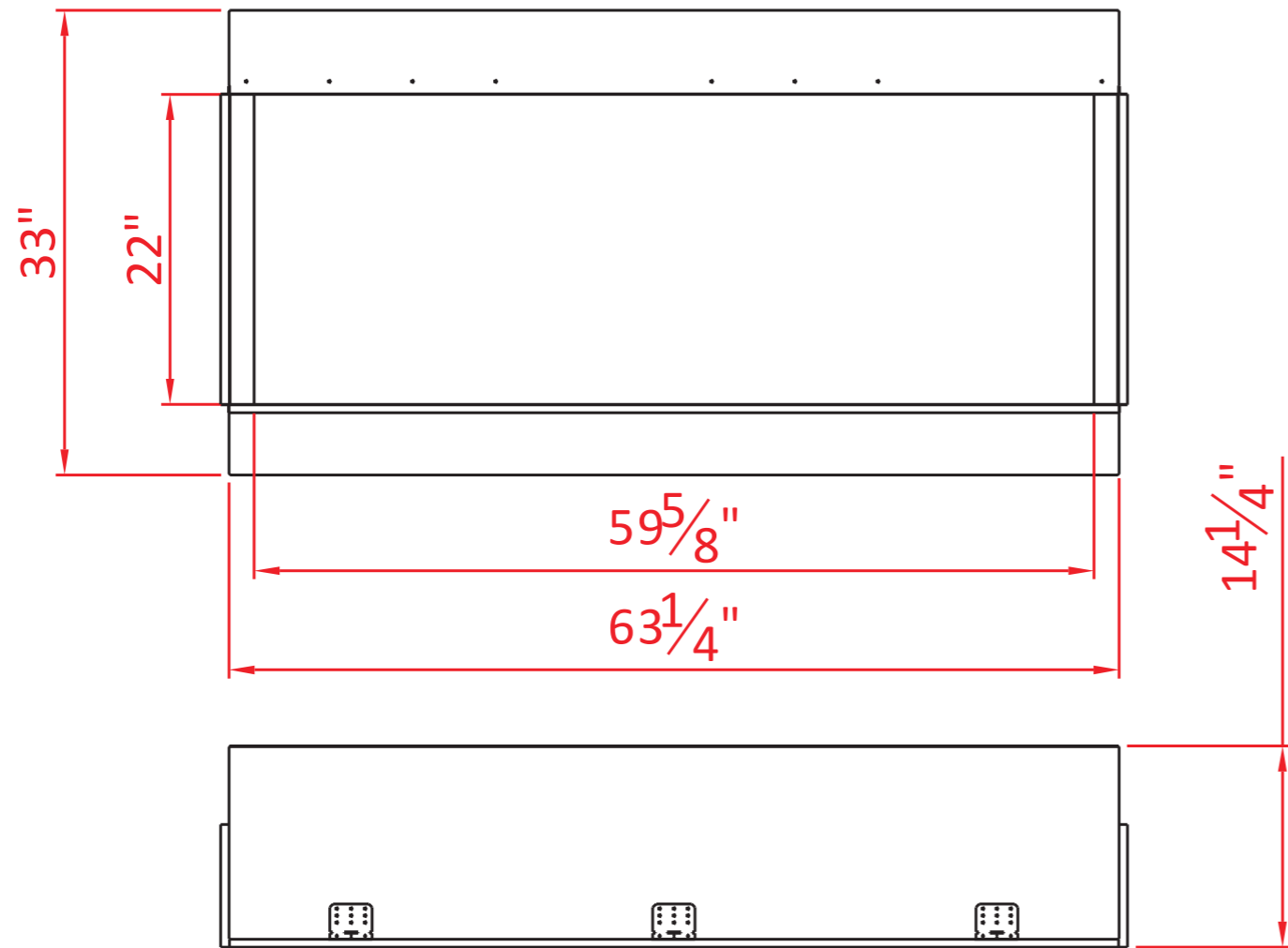

TECHNICAL SPECIFICATIONS		
VOLTS		120
AMPS		12.5
WATTS		1465
HEATER	HIGH	1465 watts
	LOW	750 watts
NO HEATER		19 watts
LAMPS	TYPE	LED
	WATTS	
	TOTAL WATTS	54 watts
ROTOR MOTOR		2 at 5 watts
HEIGHT,WIDTH,DEPTH		33" x 63 1/4" x 13 3/4"
GLASS VIEWING OPENING		22" X 59 5/8"
GLASS SIZE		22" X 59 5/8"
SHIPPING SIZE		35 1/4" x 67 1/2" x 15 5/8"
SHIPPING WEIGHT		169.8 lbs
	UNIT	150.4 lbs
	GLASS FRONT	Included
PLUG LOCATION		Left Side
CORD LENGTH		76"
APPROX. HEATING AREA		400 sq ft



SERIES	MODEL		REV
TRU VIEW	60-TRV-XL-XT		1
SCALE 1"=1'-0"	DATE: 9/19/2019	SHEET 1 OF 1	

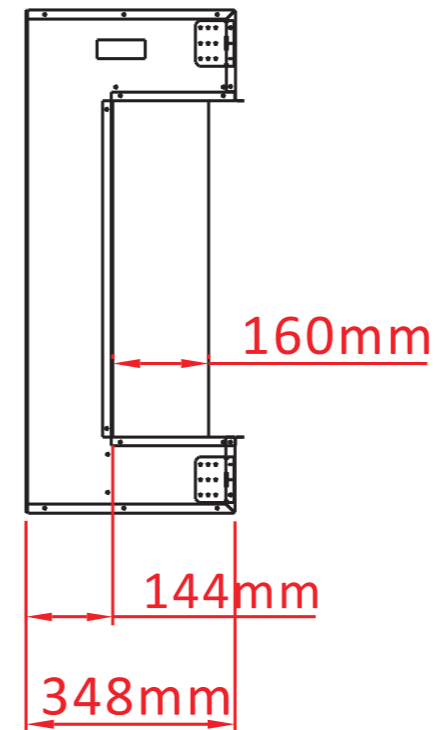
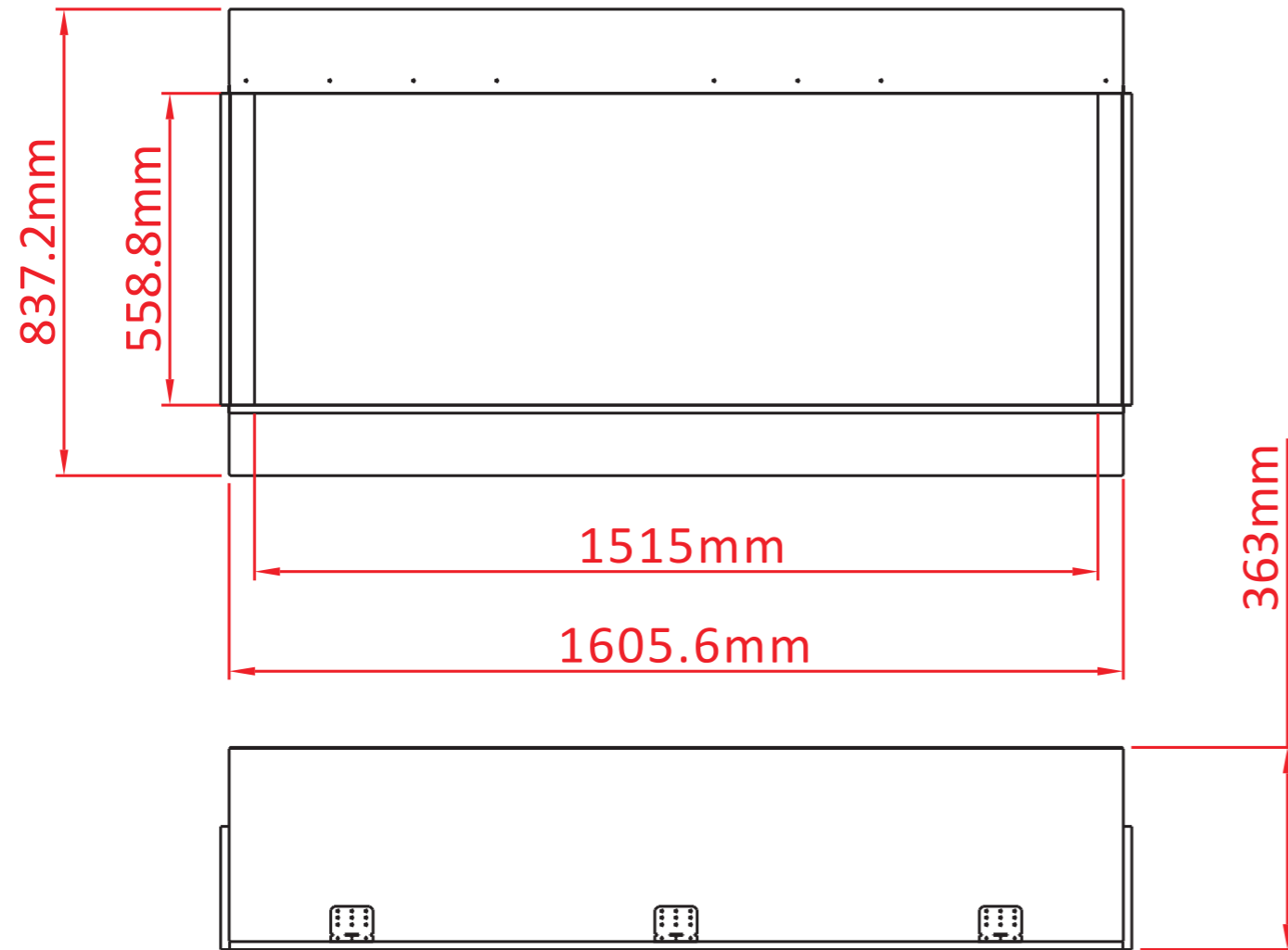

TECHNICAL SPECIFICATIONS

VOLTS		120
AMPS		12.5
WATTS		1465
HEATER	HIGH	1465 watts
	LOW	750 watts
NO HEATER		19 watts
LAMPS	TYPE	LED
	WATTS	
	TOTAL WATTS	54 watts
ROTOR MOTOR		2at 5 watts
HEIGHT,WIDTH,DEPTH		83.7 x 160.6 x 34.8 cm
GLASS VIEWING OPENING		55.9 X 151.5 cm
GLASS SIZE		55.9 X 151.5 cm
SHIPPING SIZE		89.6 x 171.6 x 39.8 cm
SHIPPING WEIGHT		77 Kgs
	UNIT	68.2 Kgs
	GLASS FRONT	Included
PLUG LOCATION		Left Side
CORD LENGTH		193 cm
APPROX. HEATING AREA		37 sqm



SERIES	MODEL		REV
TRU VIEW	60-TRV-XL-XT		1
SCALE 1:12	DATE: 9/19/2019	SHEET 1 OF 1	

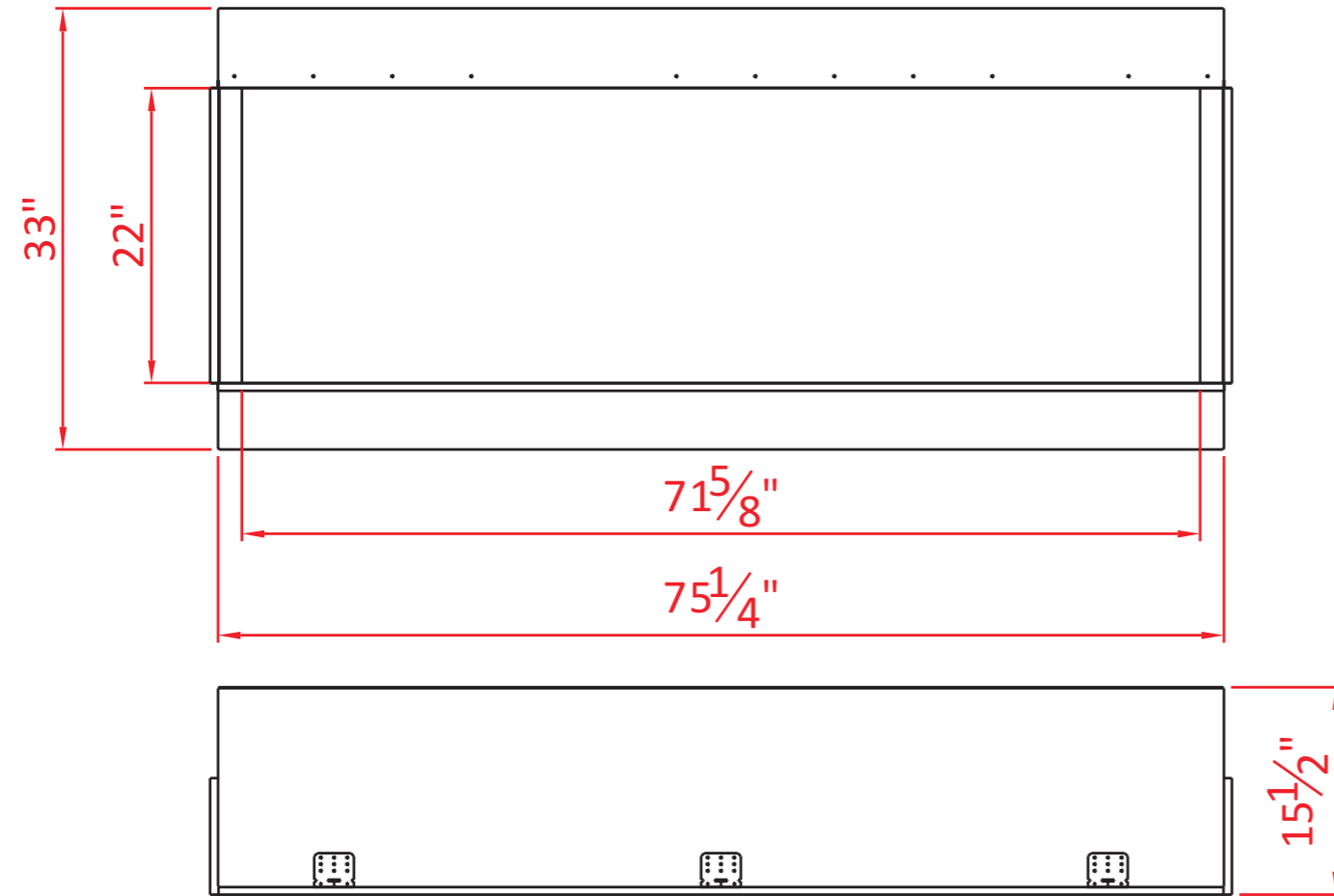

TECHNICAL SPECIFICATIONS

VOLTS		120
AMPS		12.5
WATTS		1465
HEATER	HIGH	1465 watts
	LOW	750 watts
NO HEATER		19 watts
LAMPS	TYPE	LED
	WATTS	
	TOTAL WATTS	60 watts
ROTOR MOTOR		2 at 5 watts
HEIGHT,WIDTH,DEPTH		33" x 75 1/4" x 13 3/4"
GLASS VIEWING OPENING		22" X 71 5/8"
GLASS SIZE		22" X 71 5/8"
SHIPPING SIZE		35 1/4" x 79 5/8" x 15 5/8"
SHIPPING WEIGHT		200.6 lbs
	UNIT	174.4 lbs
	GLASS FRONT	Included
PLUG LOCATION		Left Side
CORD LENGTH		76"
APPROX. HEATING AREA		400 sq ft

Amantii

SERIES	MODEL		REV
TRU VIEW	72-TRV-XL-XT		1
SCALE 1"=1'-0"	DATE: 9/19/2019	SHEET 1 OF 1	

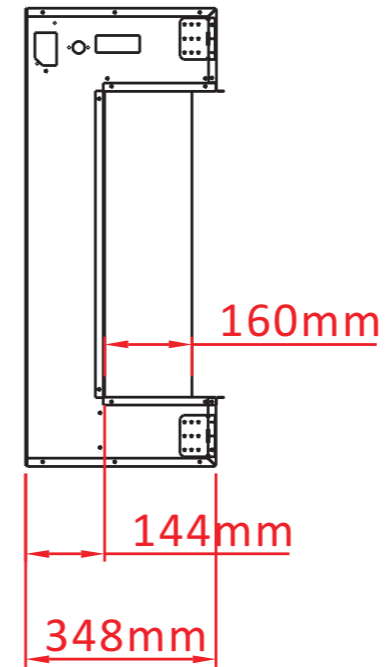
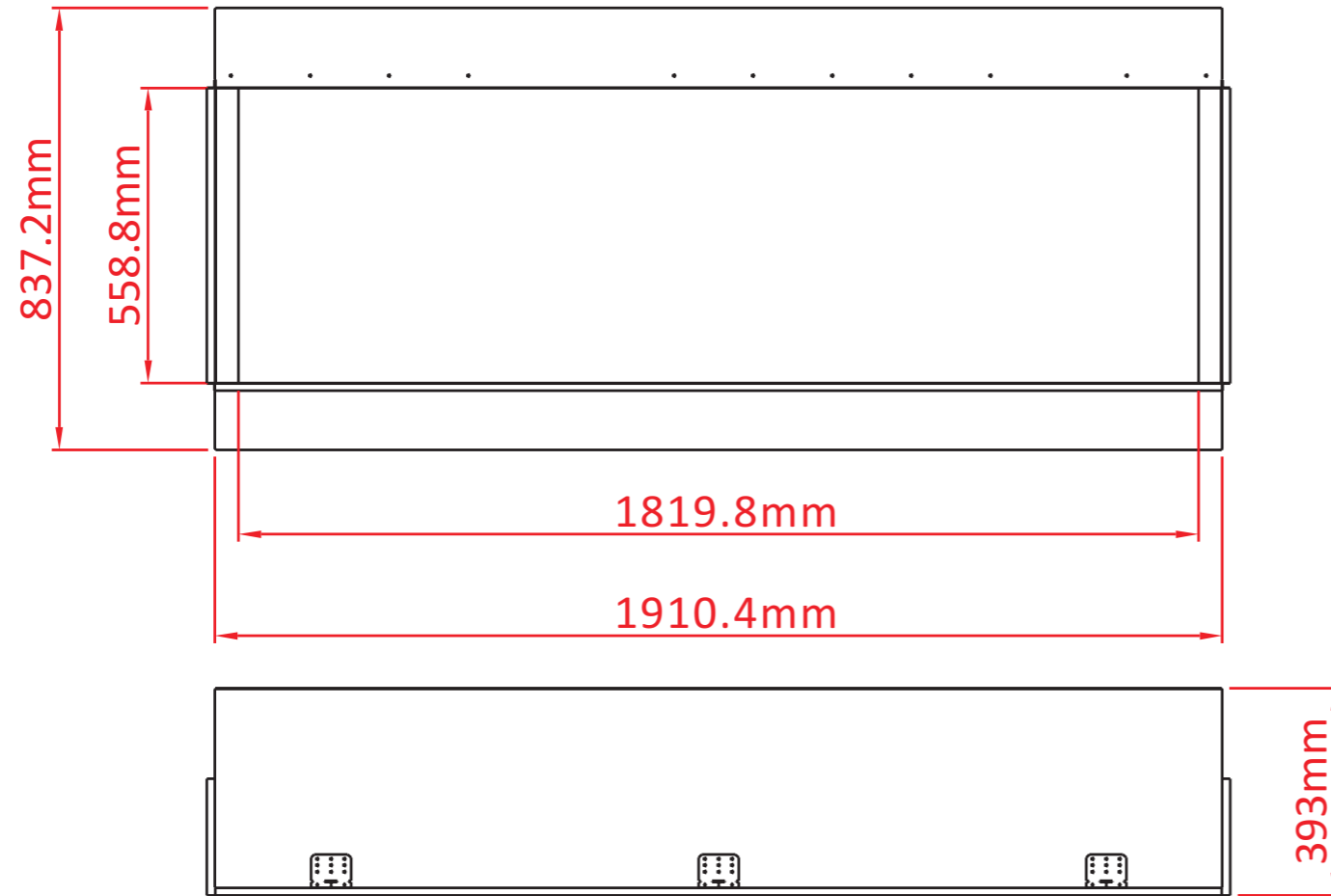

TECHNICAL SPECIFICATIONS

VOLTS		120
AMPS		12.5
WATTS		1465
HEATER	HIGH	1465 watts
	LOW	750 watts
NO HEATER		19 watts
LAMPS	TYPE	LED
	WATTS	
	TOTAL WATTS	60 watts
ROTOR MOTOR		2 at 5 watts
HEIGHT,WIDTH,DEPTH		83.7 x 191 x 34.8 cm
GLASS VIEWING OPENING		55.9 X 182 cm
GLASS SIZE		55.9 X 182 cm
SHIPPING SIZE		89.6 x 202.1 x 39.8 cm
SHIPPING WEIGHT		91 Kgs
	UNIT	79.1 Kgs
	GLASS FRONT	Included
PLUG LOCATION		Left Side
CORD LENGTH		193 cm
APPROX. HEATING AREA		37 sqm

Amantii

SERIES	MODEL		REV
TRU VIEW	72-TRV-XL-XT		1
SCALE 1:12	DATE: 9/19/2019	SHEET 1 OF 1	

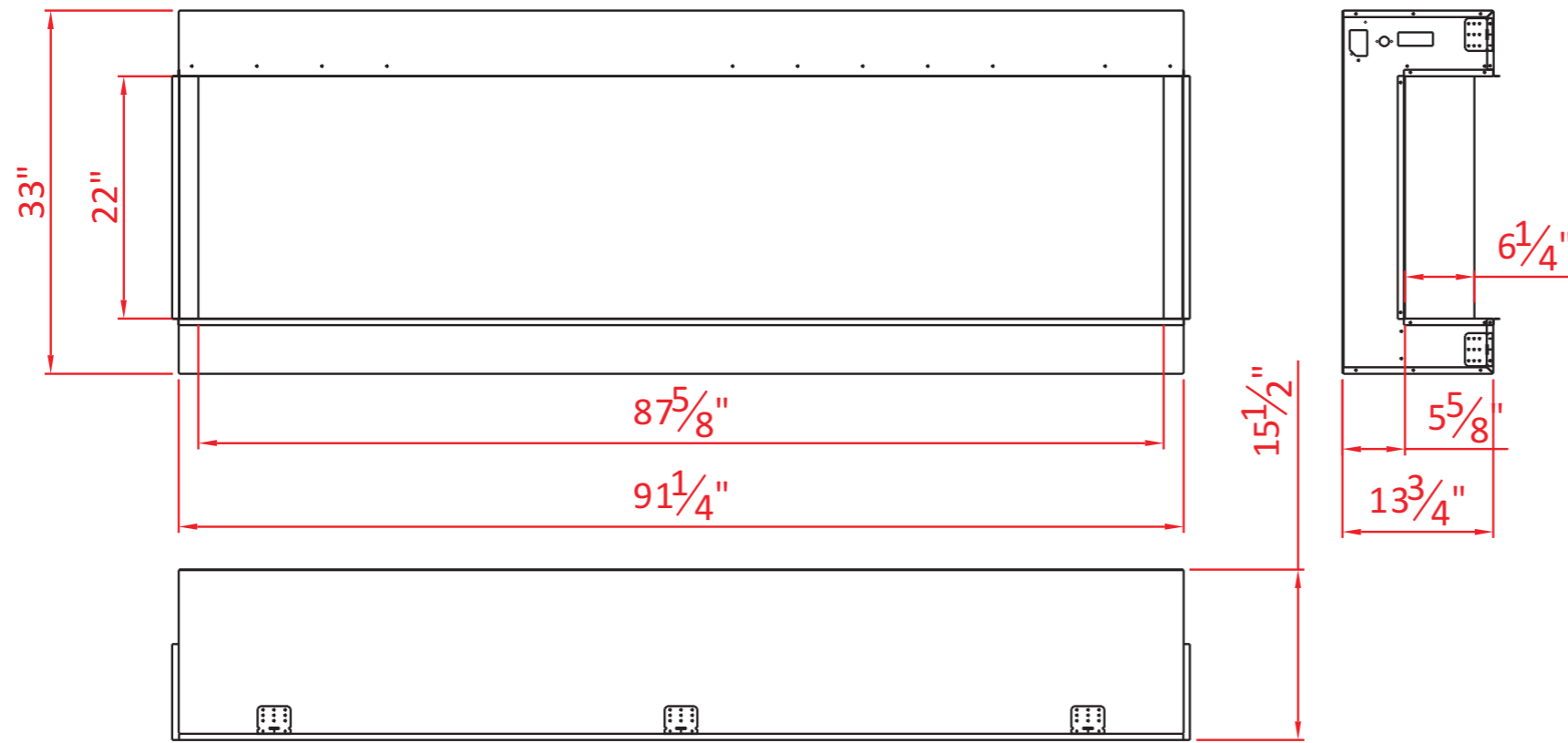

TECHNICAL SPECIFICATIONS

VOLTS		120
AMPS		12.5
WATTS		1465
HEATER	HIGH	1465 watts
	LOW	750 watts
NO HEATER		19 watts
LAMPS	TYPE	LED
	WATTS	
	TOTAL WATTS	67 watts
ROTOR MOTOR		2 at 5 watts
HEIGHT,WIDTH,DEPTH		33" x 91 1/4" x 13 3/4"
GLASS VIEWING OPENING		22" X 87 5/8"
GLASS SIZE		22" X 87 5/8"
SHIPPING SIZE		35 1/4" x 95 1/2" x 15 5/8"
SHIPPING WEIGHT		231.5 lbs
	UNIT	198.4 lbs
	GLASS FRONT	Included
PLUG LOCATION		Left Side
CORD LENGTH		76"
APPROX. HEATING AREA		400 sq ft

Amantii

SERIES	MODEL		REV
TRU VIEW	88-TRV-XL-XT		1
SCALE 1"=1'-0"	DATE: 9/19/2019	SHEET 1 OF 1	

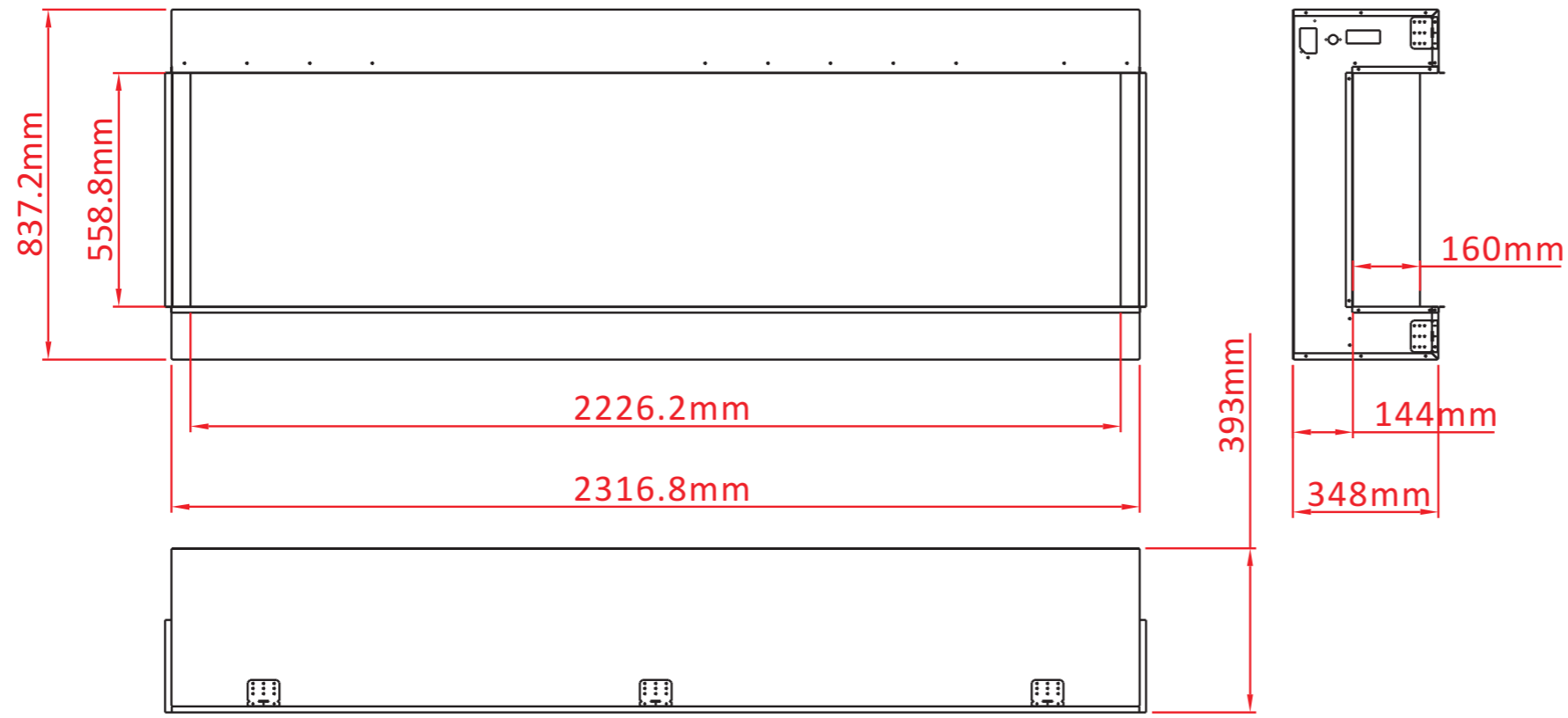

TECHNICAL SPECIFICATIONS

VOLTS		120
AMPS		12.5
WATTS		1465
HEATER	HIGH	1465 watts
	LOW	750 watts
NO HEATER		19 watts
LAMPS	TYPE	LED
	WATTS	
	TOTAL WATTS	67 watts
ROTOR MOTOR		2 at 5 watts
HEIGHT,WIDTH,DEPTH		83.7 x 231.7 x 34.8 cm
GLASS VIEWING OPENING		55.9 X 222.6 cm
GLASS SIZE		55.9 X 222.6 cm
SHIPPING SIZE		89.6 x 242.7 x 39.8 cm
SHIPPING WEIGHT		105 Kgs
	UNIT	90 Kgs
	GLASS FRONT	Included
PLUG LOCATION		Left Side
CORD LENGTH		193 cm
APPROX. HEATING AREA		37 sqm

Amantii

SERIES	MODEL		REV
TRU VIEW	88-TRV-XL-XT		1
SCALE 1:12	DATE: 9/19/2019	SHEET 1 OF 1	