

Slider L70



L70 is the coplanar system for cabinets with doors weighing up to 70 kg each. Thanks to the exclusive patented design of the Slider range, the precision-built carriages and tracks and to the revolutionary linear magnetic damper, **L70** delivers the smoothness and lightness of touch typical of Salice even with particularly heavy doors.

Available in two- or three-door variants, it can be specified with a customisable front cover. Its features of reliability, modularity and capacity make **L70** ideal for wardrobes in the bedrooms and for all large cabinets in general.





Technical information

Coplanar two and three-door system with linear magnetic damper.
Capacity 70 kg per door.

Individual door properties:

- max. weight per door 70 kg
(evenly distributed)
- width: - min. 800 mm
- max. 2000 mm
- height: - max. 3000 mm
- thickness: - min. 18 mm
- max. with handle 45 mm
- material: a) wood or derived material
b) glass with metal frame

Door adjustment:

- vertical adjustment ± 5 mm
- horizontal adjustment ± 3.5 mm
- front adjustment: - upper ± 4 mm
- lower $\pm 1,5$ mm

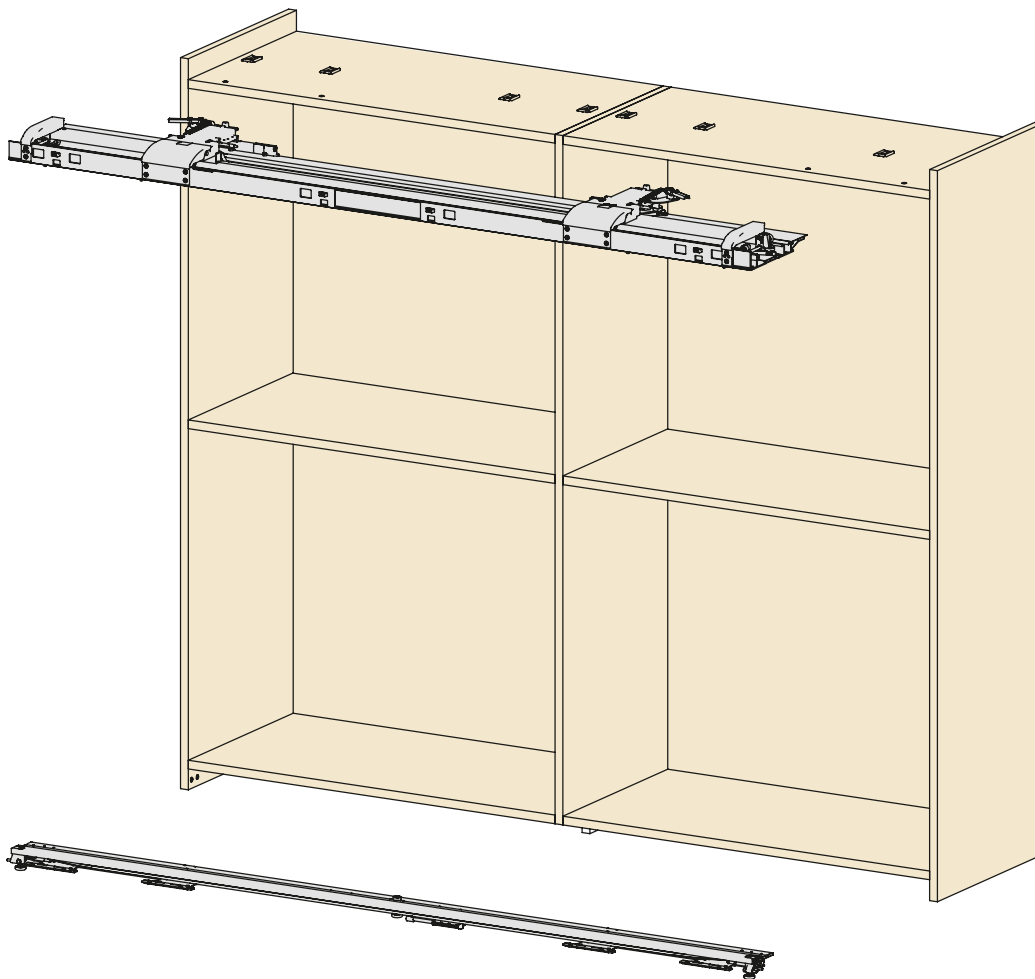

Key feature

- Soft closing with magnetic technology.
- Aluminium and PVC guide tracks for smooth, silent movement.
- Pre-assembled mechanism for fast, safe assembly.
- Cushioned opening and closing.
- Extremely tough and long-lasting, subjected to 100,000 cycles of the stress test.
- Available also in 3-door configuration.

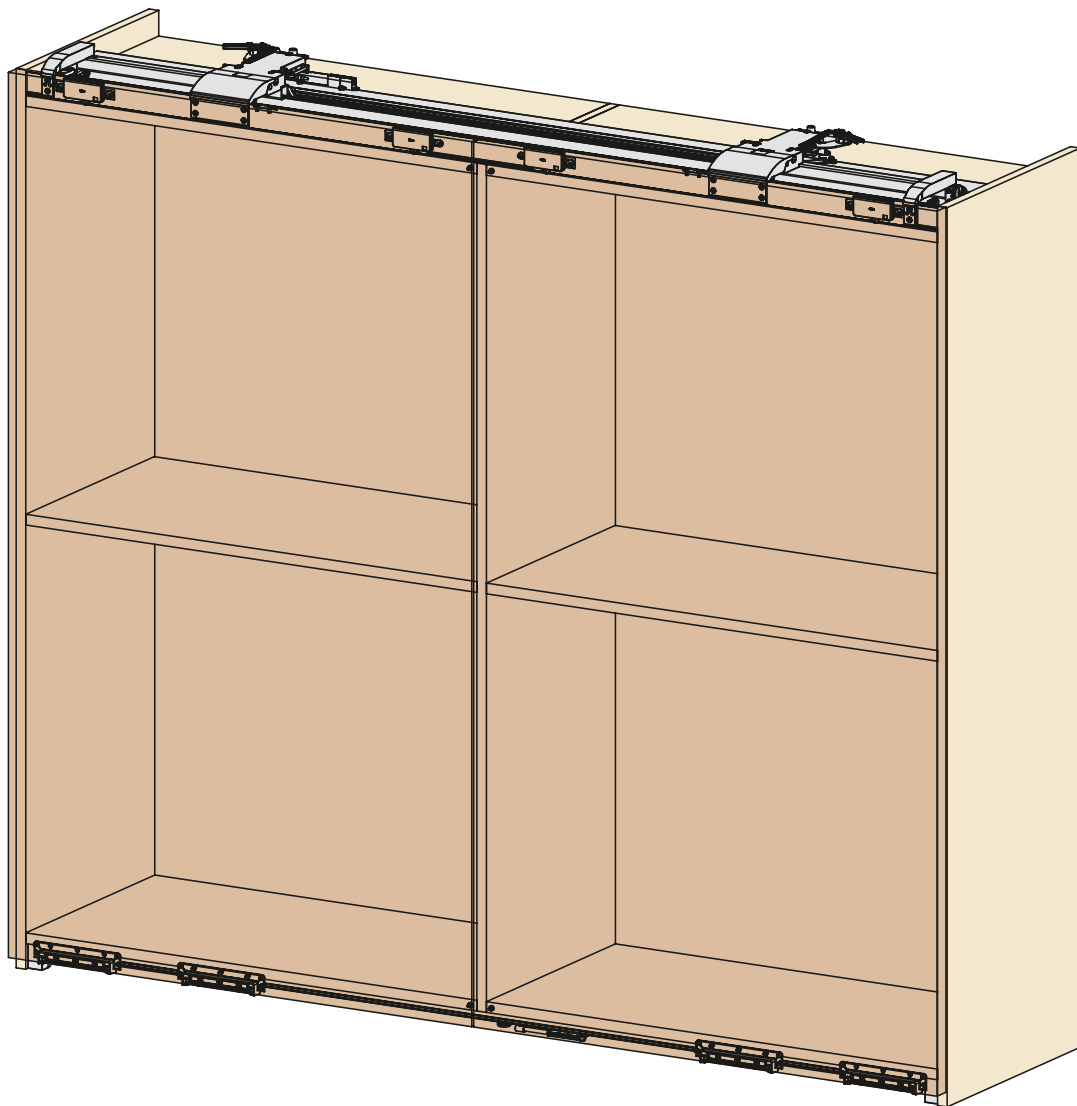

Possible solutions

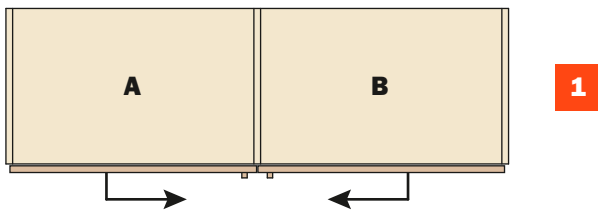

A Total opening
B Total opening

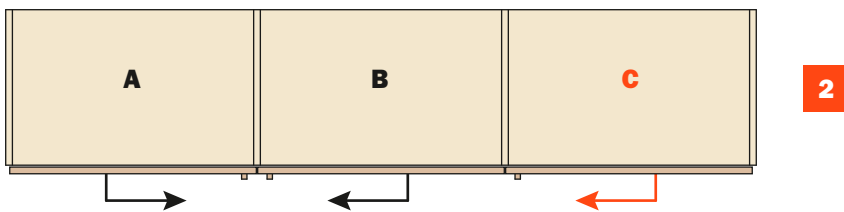

A Total opening
B Total opening
C Partial opening

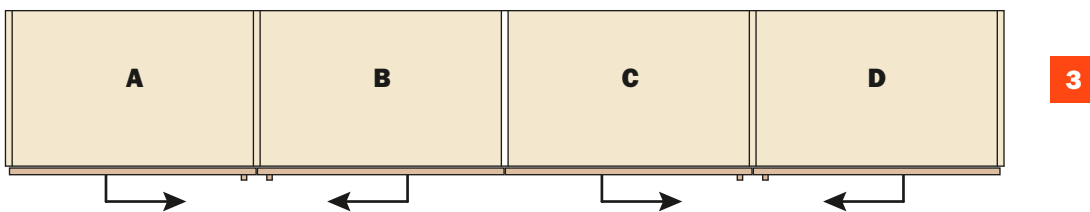

A Total opening
B Total opening
C Total opening
D Total opening

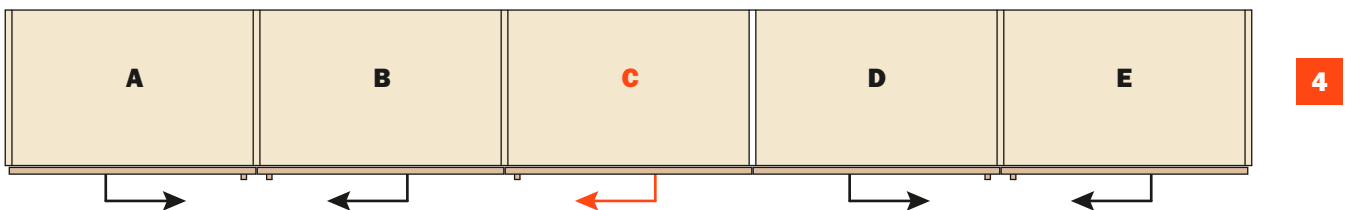

A Total opening
B Total opening
C Partial opening
D Total opening
E Total opening

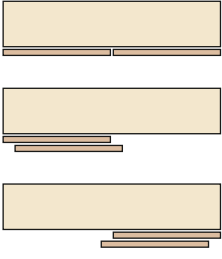
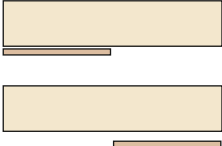
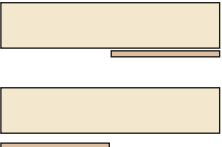
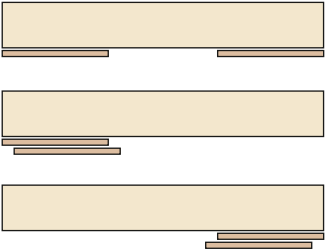
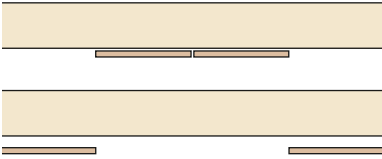
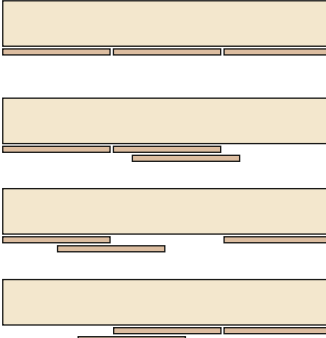
<p>Standard</p>		<p>Slider L70 Slider L100</p>	
<p>One</p>		<p>Slider L70</p>	
<p>One</p>		<p>Slider L70</p>	
<p>Step</p>		<p>Slider L70 Slider L100</p>	
<p>Reverso</p>		<p>Slider L70</p>	
<p>Three doors</p>		<p>Slider L70</p>	