



Air
SALICE

Air - The truly concealed hinge



Air is an innovative and revolutionary hinge which, despite its compactness and small size, delivers full functionality to furniture manufacturers.

The hinge is fully adjustable in three directions and also incorporates an integrated soft close mechanism for decelerated closing or the Push self-opening system for handle-less doors.

Air is inserted into the top and bottom of the cabinet and the door and is practically invisible.

Its small size means that the applications for Air are numerous: kitchens, bathrooms, living- and bedroom furniture or display cabinets.

A masterpiece of compactness in design, imperceptible and unseen just like air: Air is the new fusion of technology and aesthetics.





Technical features

Air hinges, with integrated soft close mechanism or Push self-opening system, are small and compact. They are fitted to the top and bottom panel of the cabinet.

For min. 18 mm thick wooden doors and for aluminium-framed doors.
 Max. door weight 20 Kg.
 Max. dimensions of the door : height 2100 mm, width 600 mm.
 16.5 mm deep metal cup.
 L = 2.5 mm
 105° opening.
 Possible drilling distance on the door (K): from 4 to 6 mm for wooden doors.
 Fixed K = 4 mm for aluminium-framed doors.

Space needed to open the door

The above values are calculated on the assumption that the doors have square edges. They are reduced if the doors have radiussed edges.

	T=	18	20	22	24	26	28	30	32
K=4	A=	0	0.2	0.4	0.8	1.3	3.9	6.5	9.0
K=5	A=	0	0.2	0.4	0.8	1.3	2.9	5.5	8.0
K=6	A=	0	0.2	0.4	0.8	1.2	1.9	4.5	7.0

	T=	28	30	32
K=4	A=	1.8	3.2	4.8
K=5	A=	1.7	2.8	4.3
K=6	A=	1.6	2.8	4.0

105° door opening

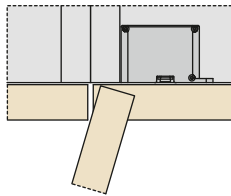

Door opening with stop device at 92°

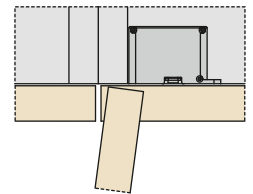

Projection of the door

Projection of the door from the cabinet side at the max. opening. The figures are based on K value = 4 and door overlay = 17 mm.

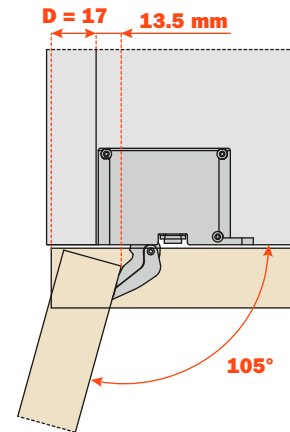

Drilling scheme for the hinge

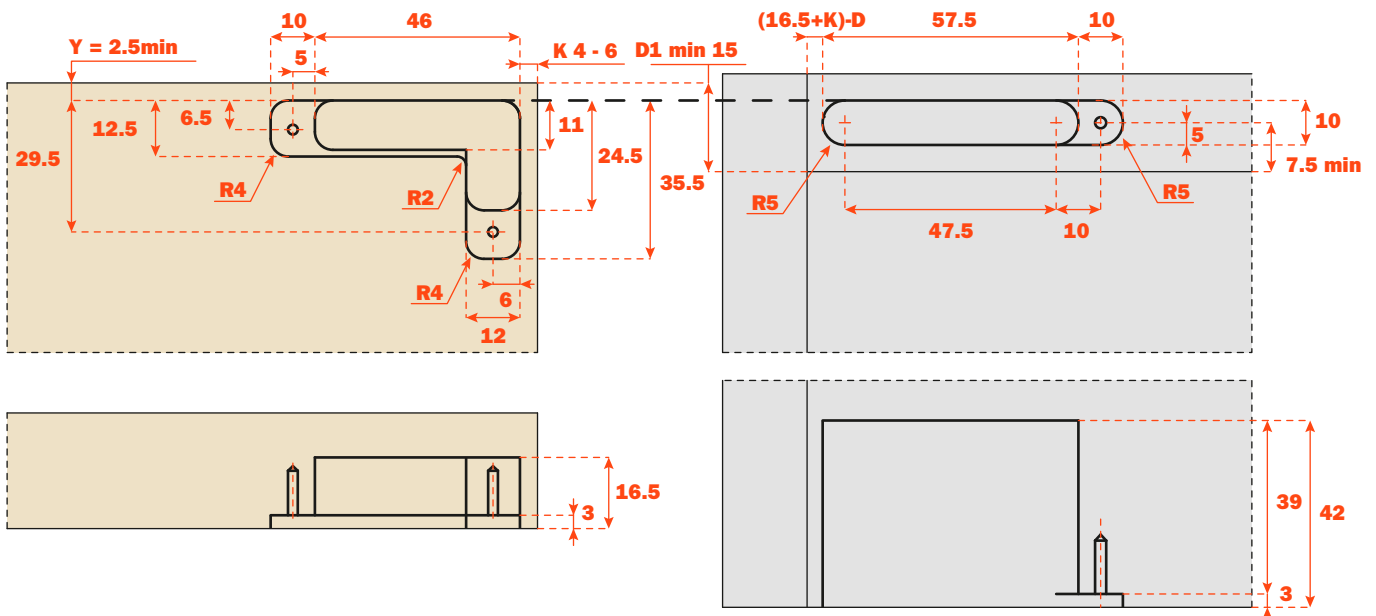

Workings on the wooden door for holders

Air can be equipped with holders for the hinge cup and arm. The holders are inserted respectively into the door and the cabinet and make the insertion of the hinge easier as well as hiding any surface imperfections caused by the machining of the cabinet.

The holder for the arm, which is inserted into the panel, provides additional support for Air when it is used in thinner materials. We recommend the use of a low-expansion, single-component polyurethane adhesive, suitable for bonding wood to metal.

Moreover, to supplement the adhesive bond, it is possible to insert two 3.5x20 screws (not supplied) through the bottom of the holder.

The holders are available in two colours, for hinges with nickel-plated and titanium finish.

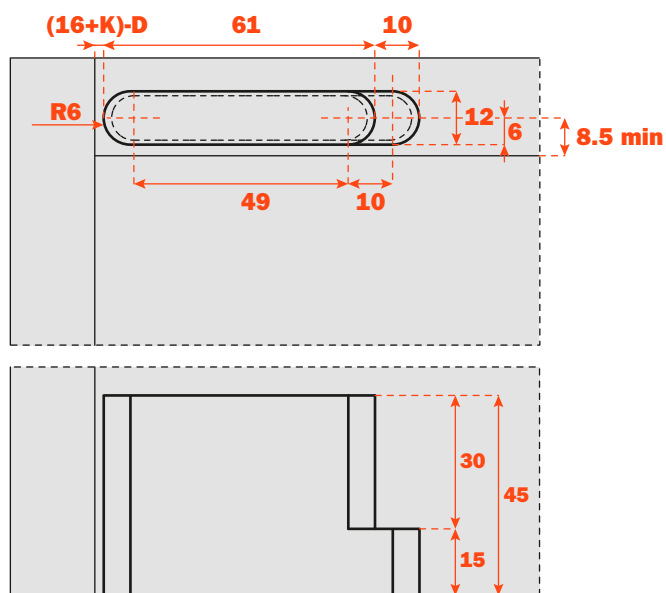
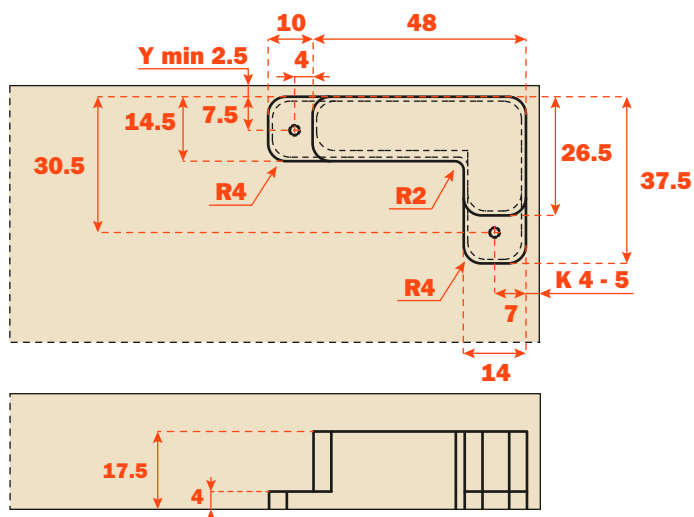

Formulas to determine the distance for the insertion of the holders for arm.

$$A = B + C$$

$$B = A - C$$

$$C = A - B$$

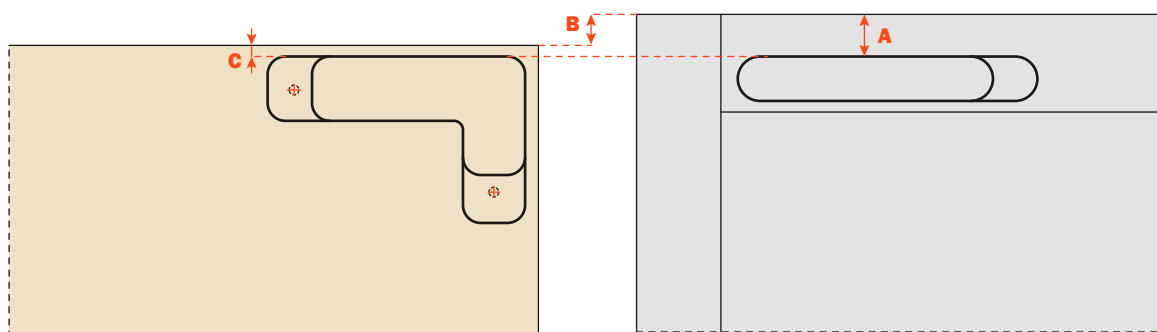



Workings on the aluminium frame DEL6LP300_.

Dimensions of the frame 26x26 mm.

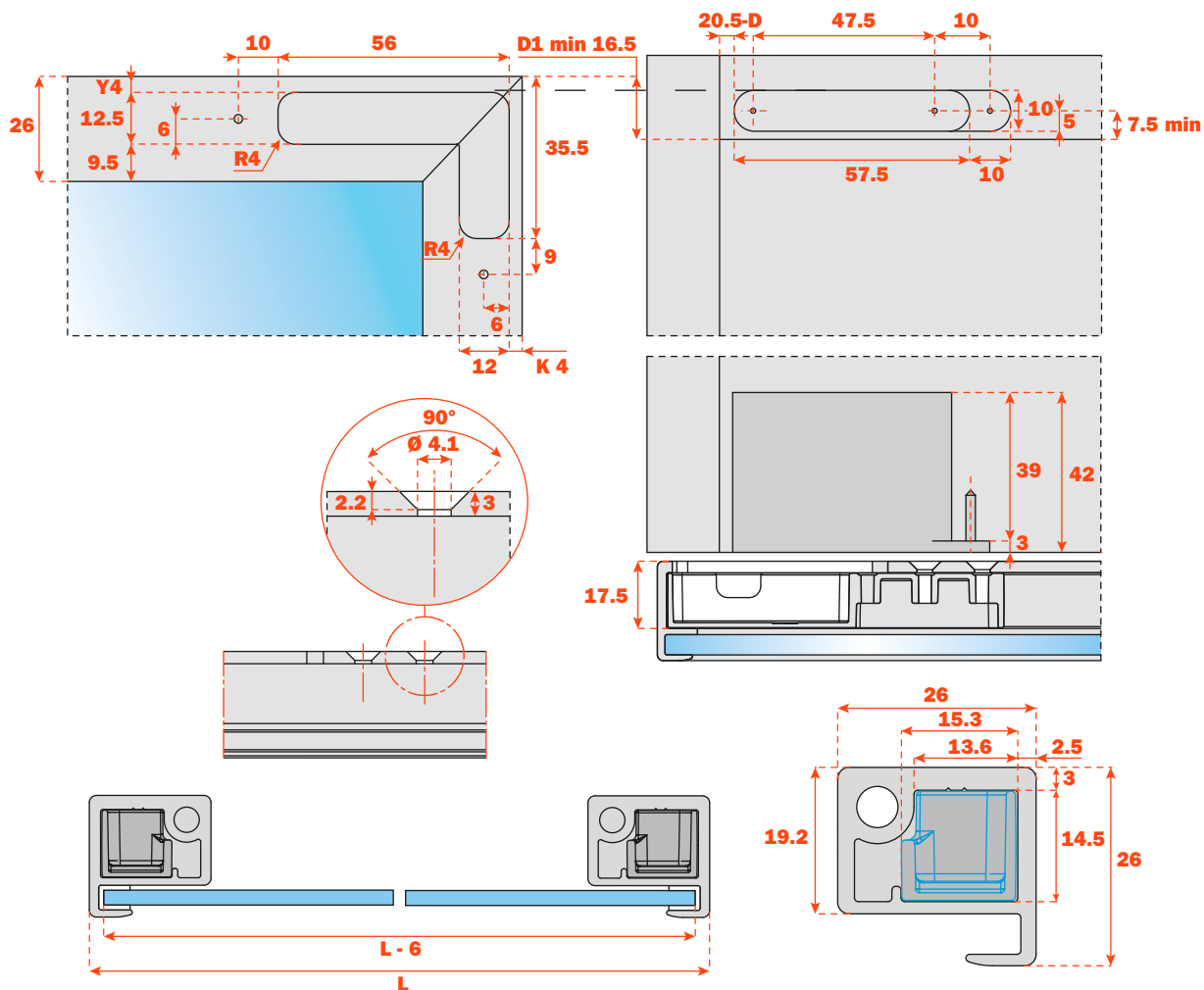

Formulas to determine the distance for the insertion of the holders for arm.

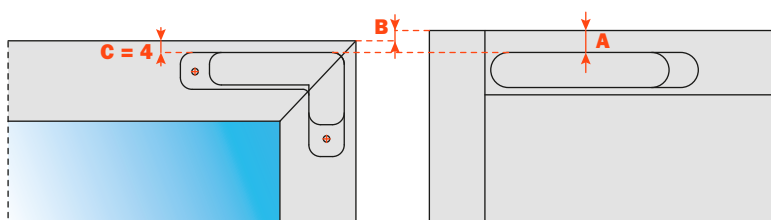

$$A = B + 4$$

$$B = A - 4$$



Workings on the aluminium frame DEL9LP300_.

Dimensions of the frame 26x19 mm.

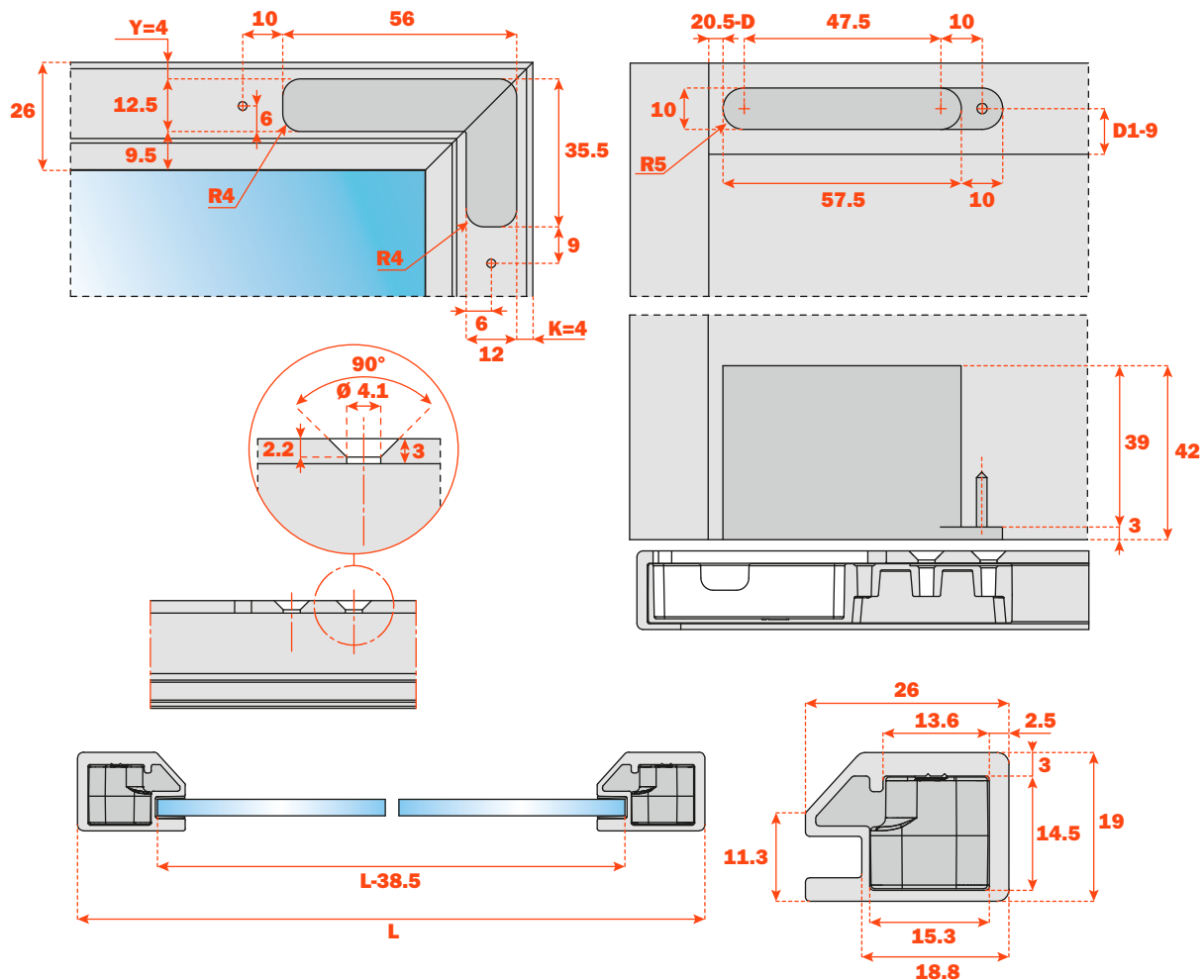

Formulas to determine the distance for the insertion of the holders for arm.

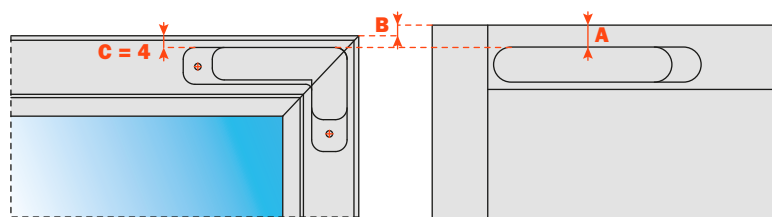

$$A = B + 4$$

$$B = A - 4$$

INDUSTRIAL PACKING



Closing/Opening action	Nickel-plated finish	Titanium finish	Industrial packing
Soft close	CEL6DE9XXI	CEL6DE6XXI	Boxes 100 pcs. Pallets 2.400 pcs. · Fixing screws included
Push	CELPD99XXI	CELPD66XXI	

Closing/Opening action	Nickel-plated finish	Titanium finish	Industrial packing
Soft close	CEL6SE9XXI	CEL6SE6XXI	Boxes 100 pcs. Pallets 2.400 pcs. · Fixing screws included
Push	CELPS99XXI	CELPS66XXI	

DOOR-SET PACKING



Closing/Opening action	Nickel-plated finish	Titanium finish	Door-set packing
Soft close	CEL6XE9XXV	CEL6XE6XXV	Box 12 bags Large boxes 72 bags Pallets 864 bags · 1 bag contains 1door-set of hinges and fixing screws
Push	CELPX99XXV	CELPX66XXV	



Corner connectors for the frame assembly of the doors and the fixing of the hinge.

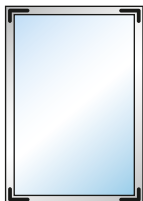

Part number	Packing
DEL6BSFV02	Boxes of 25 bags 1 bag contains: 4 corner connectors and assembly screws

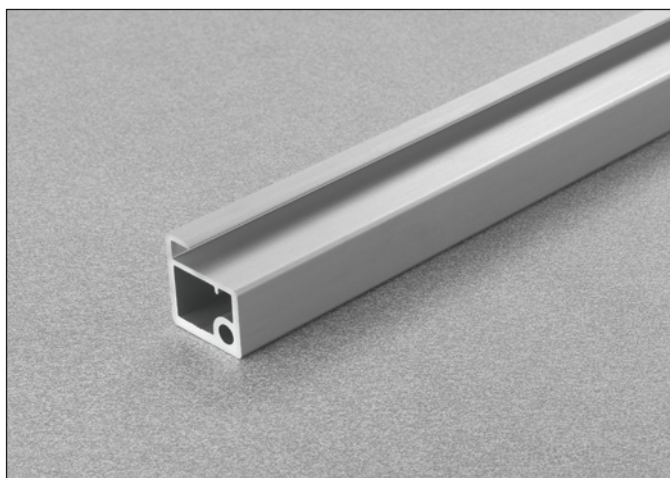

Aluminium door profile, width 26 mm, for glass insertion (4 mm).

Part number	Packing	Length
DEL6LP300P	12 lengths in anodised aluminium	3 metres
DEL6LP300T	12 lengths in Titanium finish	3 metres

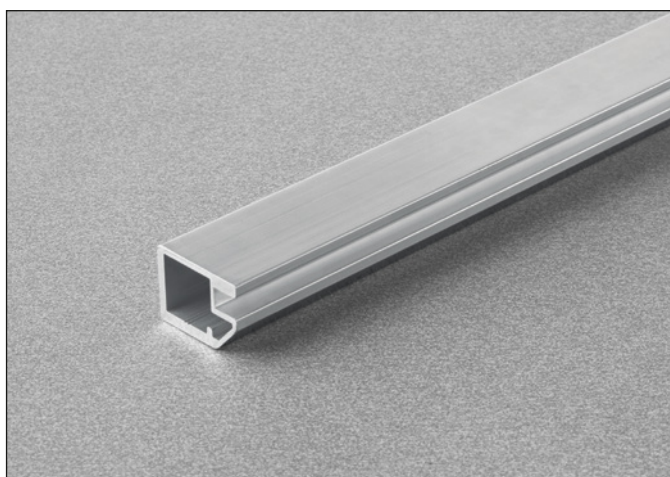

Aluminium door profile, width 19 mm, for glass insertion (4 mm).

Part number	Packing	Length
DEL9LP300P	14 lengths in anodised aluminium	3 metres
DEL9LP300T	14 lengths in Titanium finish	3 metres

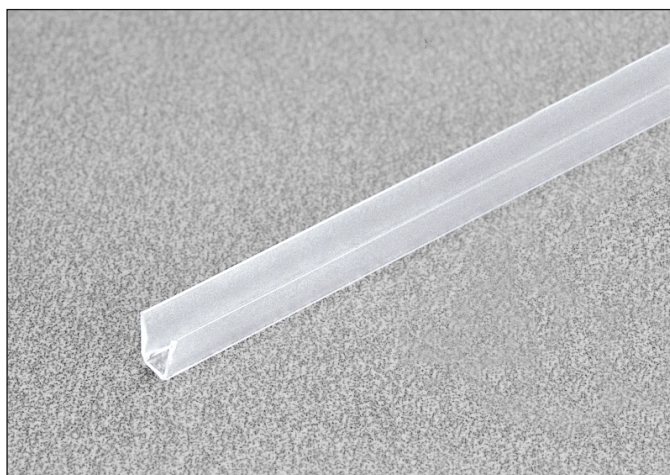

Gasket for glass.

Part number	Packing	Length
D206AG3000	120 gaskets	3 metres

Air - Aluminium frame assembly

The profiles which make up the door must be cut and the ends mitred at 45°, and milled for the insertion of the corner connectors.

Insert the corner connectors into the profile and fix them with the screws provided.

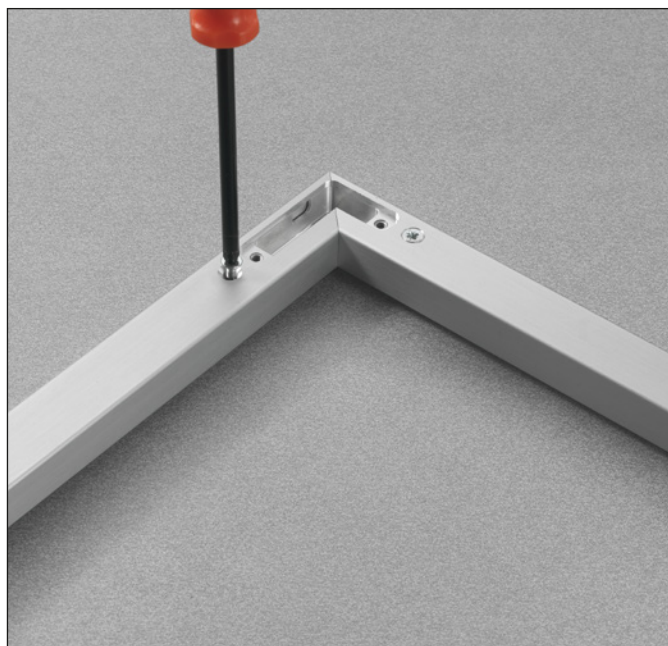
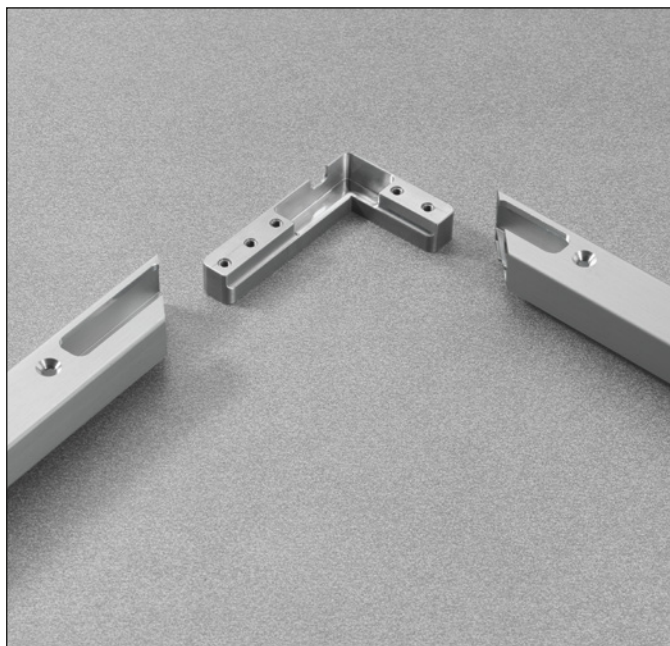

Insert the hinges into the recesses.

Fix with the screws provided.

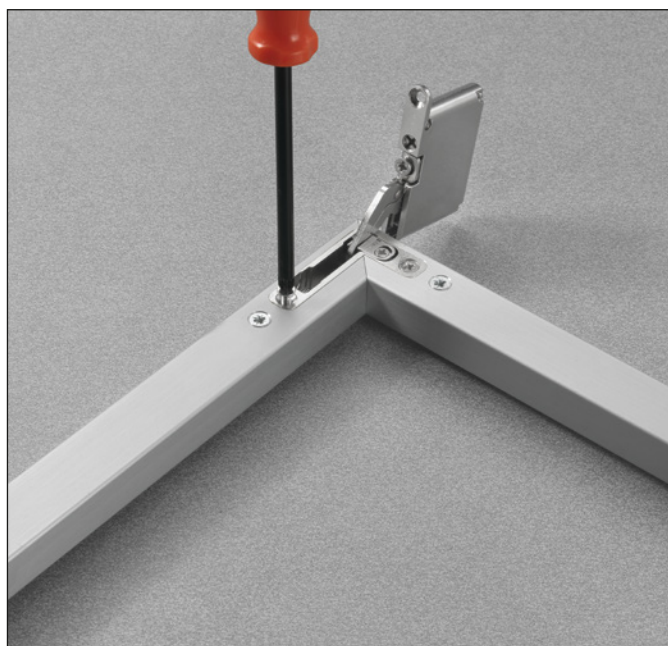
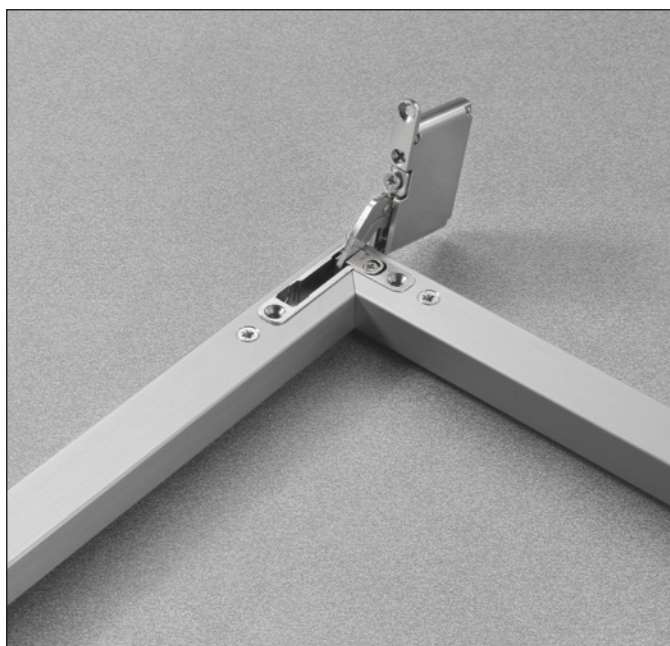



Restrictor to reduce opening angle to 92 deg.

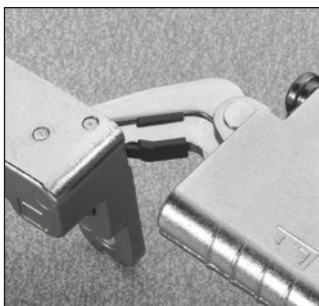

Part number	Packing
SEL637X3	Boxes of 500 pieces



Holders for cup, to be inserted into the door .
They allow an easier insertion of the hinge as well as hiding any surface imperfections caused by the machining of the door.

Part number	Packing
SELX86X6XD	Boxes of 100 pieces
SELX86X6XS	Boxes of 100 pieces



Holders for arm, to be inserted and attached into the top or bottom panel of the cabinet to provide additional support for Air when it is used in thinner materials as well as hiding any surface imperfections caused by the machining of the cabinet.

Part number	Packing
SELX77X9	Boxes of 36 bags · 1 bag contains: 2 holders 2 fixing screws for hinges
SELX77X6	Boxes of 36 bags · 1 bag contains: 2 holders 2 fixing screws for hinges

Sideways adjustment from +2 to -2

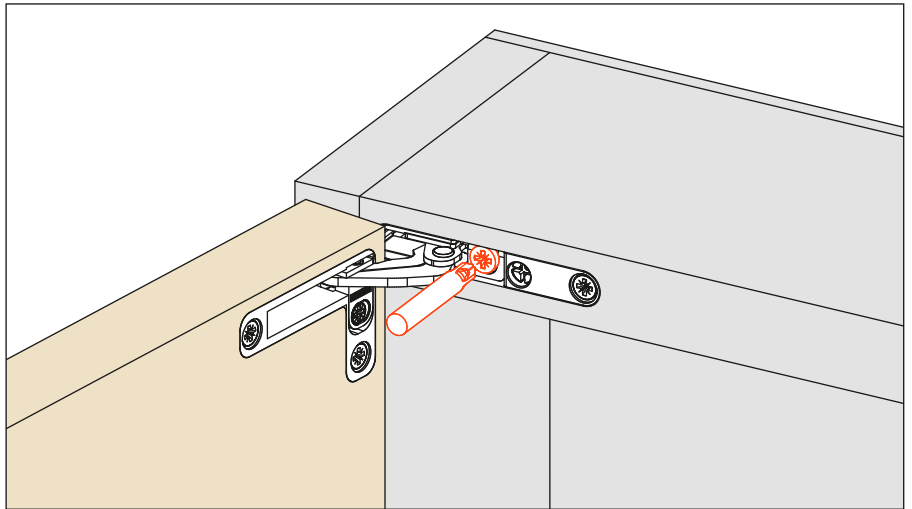
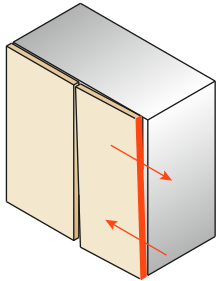

Depth adjustment from +2 to -0.5

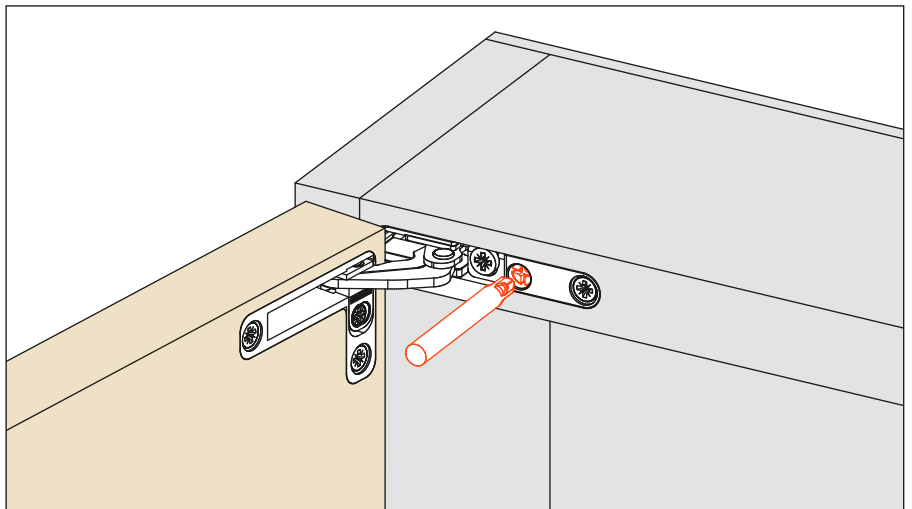
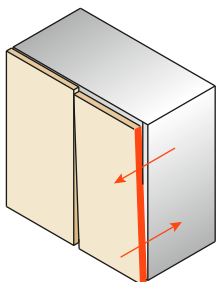

Height adjustment from +1.5 to -1.5

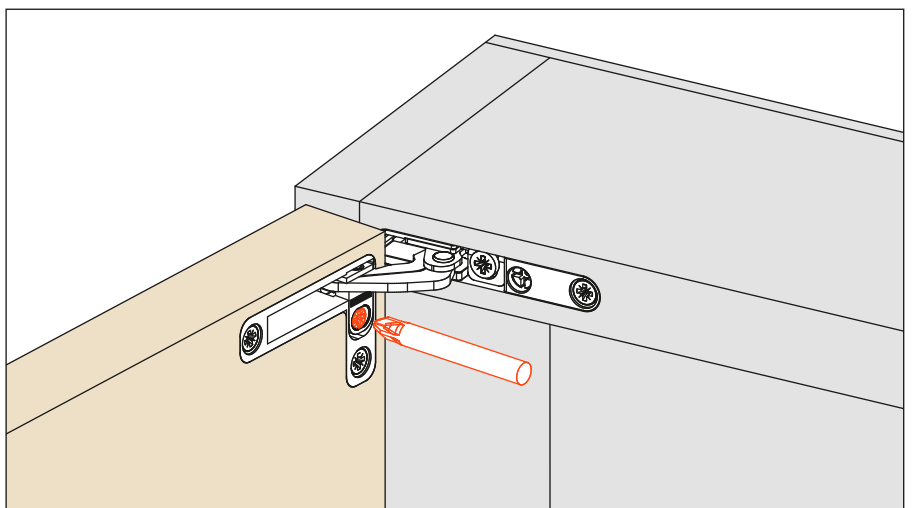
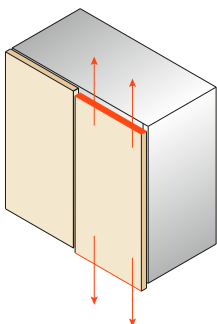

Magnetic Push



Magnetic Push - Recessed magnetic release device and retaining catches

DPMSNB - beige



DPMSNG - grey



Release device.
ø 10 mm, 40 mm length.

Packing

Boxes 250 pcs.
Cartons 1.500 pcs.

DPASNB - beige



DPASNG - grey



Optional supplementary release device to increase the magnetic holding strength. It must always be used together with the DPM. The suggested position of the DPM is the point of pressure on the door. The DPA can be positioned at any point along the opening edge of the door.
ø 10 mm, 40 mm length.

Packing

Boxes 250 pcs.
Cartons 1.500 pcs.

DP39XXG



Adjustable magnetic retaining catch.
ø16.6 mm

Packing

Boxes 250 pcs.

DP28SN9



Retaining catch to be inserted.
ø 11.5 mm.

Packing

Boxes 250 pcs.

DP38XX91



Retaining catch with adhesive.
20x14 mm.

Packing

Boxes 250 pcs.

Application of the release device to be recessed

Drill a hole \varnothing 10 mm and min. 40 mm depth in the top, the side or the base panel of the cabinet.

Insert the release device into the hole.

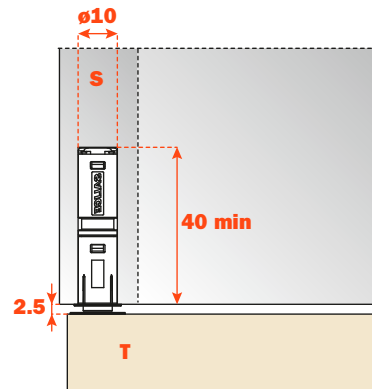

Inserted adjustable retaining catch.

The retaining catch DP39 is itself magnetic and together with the magnetism of the release device DPM considerably increase (30%) the holding strength of the door against the cabinet side, thus avoiding accidental openings.

For the installation it is necessary to drill a hole $\varnothing 15$ mm and 11 mm depth in the door.

Depth adjustment from -0.5 mm to +2.5 mm.

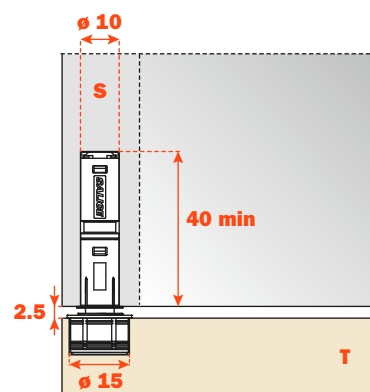

Pin- fix retaining catch

Apply the retaining catch to the magnetic release device.

Close the door.

The point of the retaining catch will show where to insert it.

Reopen the door and drive in the pin to fix in position.

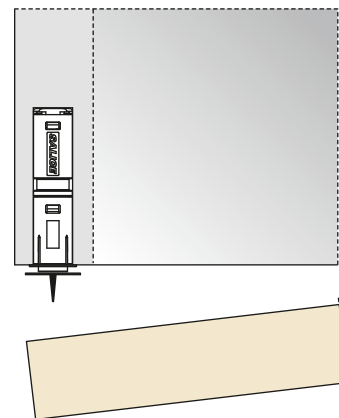

Retaining catch with adhesive strip

Apply the retaining catch to the magnetic release device. Remove the protective strip from the adhesive. Close the door. In this way the retaining catch is positioned on the door. Reopen the door and apply a firm pressure to the retaining catch to ensure a correct installation.

ATTENTION:

For a correct application and to ensure optimal endurance, we suggest these guidelines are followed:

- 1 - clean and degrease the door surface where the retaining catch is to be installed;
- 2 - remove the protective strip from the adhesive;
- 3 - place the retaining catch in position, in a place that is at room temperature $\geq 10^\circ$ and apply a firm pressure for 10-15 seconds.

After few seconds from the installation the retaining catch is suitable for the use.

After 24h the max. hold is attained.

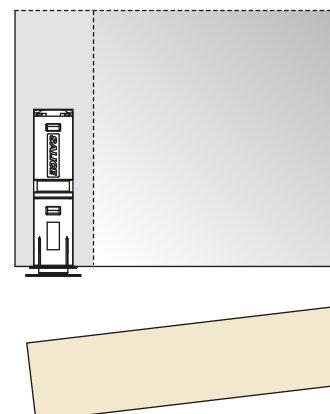

ARTURO SALICE S.p.A.

VIA PROVINCIALE NOVEDRATESE, 10
22060 NOVEDRATE (COMO) ITALIA
TEL. 031 790424 - FAX 031 791508
info.salice@salice.com - www.salice.com

DEUTSCHE SALICE GMBH

RUDOLF DIESEL STR. 10
POSTFACH 1154
74382 NECKARWESTHEIM
TEL. 07233 9807-0
FAX. 07233 9807-16
info.salice@deutschesalice.de
www.salice.com

DEUTSCHE SALICE GMBH

VERKAUFSBÜRO NORD
RINGSTRASSE 36/A30 CENTER
32584 LÖHNE
TEL. 05731 15608-0
FAX. 05731 15608-10
vknord@deutschesalice.de
www.salice.com

SALICE UK LTD.

KINGFISHER WAY
HINCHINGBROOKE BUSINESS PARK
HUNTINGDON CAMBS PE 29 6FN
TEL. 01480 413831
FAX. 01480 451489
info.salice@saliceuk.co.uk
www.salice.com

SALICE FRANCE S.A.R.L.

ROUTE DE GOA ZAC LES 3 MOULINS
06600 ANTIBES
TEL. 0493 330069
FAX. 0493 330141
info.salice@salicefrance.com
www.salice.com

SALICE ESPAÑA, S.L.U.

CALLE COPÉRNICO, 11
POLÍGONO INDUSTRIAL COLL DE LA MANYA
08403 GRANOLLERS (BARCELONA)
TEL. 938 45 88 61
FAX 938 49 11 97
info.salice@saliceespana.es
www.salice.com

SALICE PORTUGAL UNIP. Lda

VIA ROTA DOS MÓVEIS | n°399
4585-325 GANDRA-PRD (DIST. PORTO)
PORTUGAL
TEL. 0351 910077406
saliceportugal@salice.com
www.salice.com

SALICE CHINA (SHANGHAI) CO. LTD.

1st FLOOR, B1 BLDG 928 MINGZHU ROAD
XUJING, QINGPU DISTRICT
SHANGHAI 201702 - CHINA
Tel. 021 3988 9880
Fax 021 3988 9882
info.salice@salicechina.com
www.salicechina.com

SALICE CANADA INC.

3500 RIDGEWAY DRIVE,
UNIT#1
MISSISSAUGA, ONTARIO, L5L 0B4
TEL. 905 8208787
FAX. 905 8207226
info.salice@salicecanada.com
www.salicecanada.com

SALICE AMERICA INC.

2123 CROWN CENTRE DRIVE
CHARLOTTE NC. 28227
TEL. 704 8417810
FAX. 704 8417808
info.salice@saliceamerica.com
www.saliceamerica.com

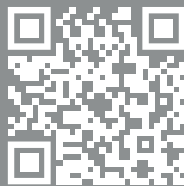

Digital contents:

- **Technical pamphlet in Pdf format**
- **Presentation in Pdf format**
- **Video**