

## SAFETY PRECAUTIONS

- IMPORTANT: READ ALL INSTRUCTIONS BEFORE THE INSTALLATION.
- WARNING: RISK OF FIRE OR ELECTRIC SHOCK. THE INSTALLATION SHOULD BE PERFORMED ONLY BY A QUALIFIED ELECTRICIAN IN ACCORDANCE WITH THE NATIONAL ELECTRICAL CODE AND RELEVANT LOCAL CODES. THIS PRODUCT MUST BE INSTALLED IN FULL ACCORDANCE WITH APPLICABLE ELECTRICAL AND BUILDING CODES.
- TO PREVENT ELECTRICAL SHOCK, MAKE SURE TO TURN OFF MAINPOWER SWITCH PRIOR TO THE INSTALLATION.
- ENSURE THAT THE AMBIENT TEMPERATURES ARE WITHIN THE LUMINAIRE'S RATED LIMITS.
- CHECK THE NAMEPLATE'S MARKING FOR MORE INFORMATION.

## INSTALLATION

### ALWAYS TURN OFF THE POWER SUPPLY FROM MAIN CIRCUIT BREAKER FIRST!

1. CAREFULLY REMOVE THE PRISMATIC LENS FROM THE LUMINAIRE.
2. USE THE LUMINAIRE AS A TEMPLATE BY PLACING IT ON THE JUNCTION BOX AND PENCILING IN THE FOUR HOLE POSITIONS. PUT THE LUMINAIRE ASIDE AND DRILL THE FOUR HOLES. INSERT AN ANCHORING BOLT (NOT INCLUDED) INTO EACH HOLE (SEE FIG. 2).
3. SECURE THE LUMINAIRE INTO PLACE WITH THE HELP OF MOUNTING SCREWS (NOT INCLUDED) ENSURING TO PASS THE JUNCTION BOX CABLES ON THE INSIDE OF THE LUMINAIRE.
4. CONNECT LUMINAIRE WIRES TO JUNCTION BOX WIRES (WIRE CONNECTORS NOT INCLUDED) AS FOLLOWS: GROUND WIRE TO FIXTURE'S GROUND WIRE, LIVE WIRE TO FIXTURE'S POWER WIRE, THEN NEUTRAL WIRE TO FIXTURE'S NEUTRAL WIRE.
5. PLACE COVER ON THE INSTALLED LUMINAIRE. CAREFULLY PUSH THE CONNECTING WIRES INTO THE LUMINAIRE.
6. INSTALL THE LAMP OR LAMPS IN THE LUMINAIRE.
7. INSTALL THE PRISMATIC LENS ON THE LUMINAIRE.
8. TURN ON THE LUMINAIRE.

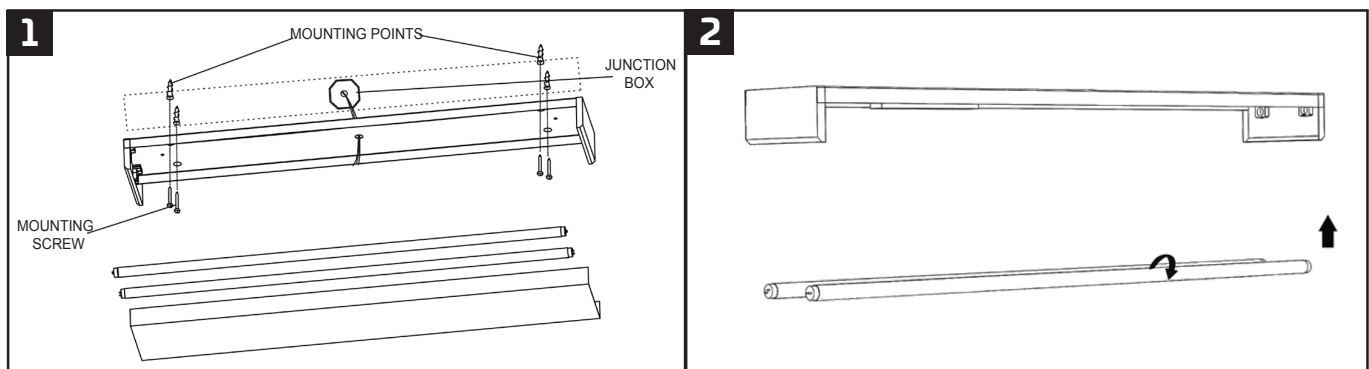

## Suspending

### 1. V-hook and chain(not be included)

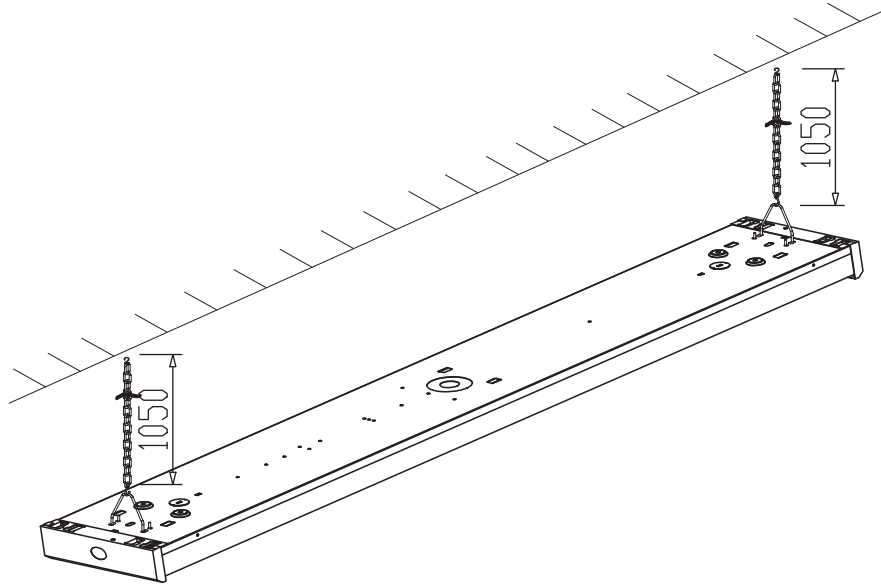

### 2. Aircraft cable(not be included)

