

LED Lighting Fixture

SAVE THESE INSTRUCTIONS



BEFORE YOU BEGIN

Read and follow all safety instructions

WARNING

RISK OF FIRE, EXPLOSION AND ELECTRIC SHOCK

- This product should be installed, inspected, and maintained by a qualified electrician only, in accordance with the NEC (National Electric Code) and all local codes.
- Turn off electrical power before inspection, installation or removal.
- Use only UL (or other NRTL) approved wire for input/output connections.
- Minimum size 18 AWG or 14 AWG for continuous runs.
- Make sure LEDs and drivers are cool to touch when performing maintenance.
- Make sure the supply voltage is the same as the rated voltage of the luminaire.
- Do not install in a hazardous atmosphere, except where the ambient temperature does not exceed the rated operating temperature of the fixture.
- Keep tightly closed when in operation



Prepare Electrical Wiring



Electrical Requirements

- The LED driver must be supplied with the voltage specified on the product label and connected to an individual, properly grounded branch circuit protected by a 20 Ampere circuit breaker. Use min. 75°C supply.



Grounding Instructions

- The grounding and bonding of the overall system shall be done in accordance with NEC Article 600 and local codes

LED Wallpack

Installation Guide

Before starting:

- Ensure that the supply power is shut off.
- Unpack the fixture and ensure that there are no damaged or missing parts.
- NOTE: Fixture must be sealed where it contacts the mounting surface with a silicone sealant.

Tools Required:

Phillips Screwdriver
Hex Key Set
Wire Strippers
Wire Cutters

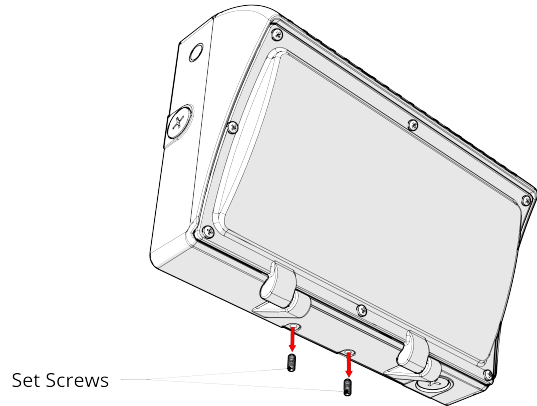

Step 1: Loosen the two (2) set screws found on the bottom of the fixture housing.

Step 2: Remove the quick mount bracket from the fixture and attach it to the junction box with the appropriate hardware (not included)

Step 3: Make the wiring connections according to the wiring diagrams on Page 4. Push excess wire into the junction box.

Step 4: Lift the fixture and tilt slightly toward the quick mount bracket. Hook the fixture housing onto the quick mount bracket as shown. Take care not to pinch any wires.

Step 5: Tighten the two (2) set screws to secure the fixture housing to the quick mount bracket.

Step 6: Restore power and check that the fixture is functioning properly.

Electrical Wiring Diagram

