

LED Lighting Fixture

SAVE THESE INSTRUCTIONS



BEFORE YOU BEGIN

Read and follow all safety instructions

WARNING

RISK OF FIRE, EXPLOSION AND ELECTRIC SHOCK

- This product should be installed, inspected, and maintained by a qualified electrician only, in accordance with the NEC (National Electric Code) and all local codes.
- Turn off electrical power before inspection, installation or removal.
- Use only UL (or other NRTL) approved wire for input/output connections. Minimum size 18 AWG or 14 AWG for continuous runs.
- Make sure LEDs and drivers are cool to touch when performing maintenance. Make sure the supply voltage is the same as the rated voltage of the luminaire.
- Do not install in a hazardous atmosphere, except where the ambient temperature does not exceed the rated operating temperature of the fixture.
- Keep tightly closed when in operation



Prepare Electrical Wiring



Electrical Requirements

- The LED driver must be supplied with the voltage specified on the product label and connected to an individual, properly grounded branch circuit protected by a 20 Ampere circuit breaker. Use min. 75°C supply.



Grounding Instructions

- The grounding and bonding of the overall system shall be done in accordance with NEC Article 600 and local codes

LED SPORTS LIGHT

Installation Guide

Before starting:

- Ensure that the supply power is shut off.
- Unpack the fixture and ensure that there are no damaged or missing parts

Tools Required:

- #2 Phillips Screw Driver
- Wire Strippers
- Wire Cutters
- Adjustable Wrench
- Socket Wrench with assorted sockets

Standard Installation

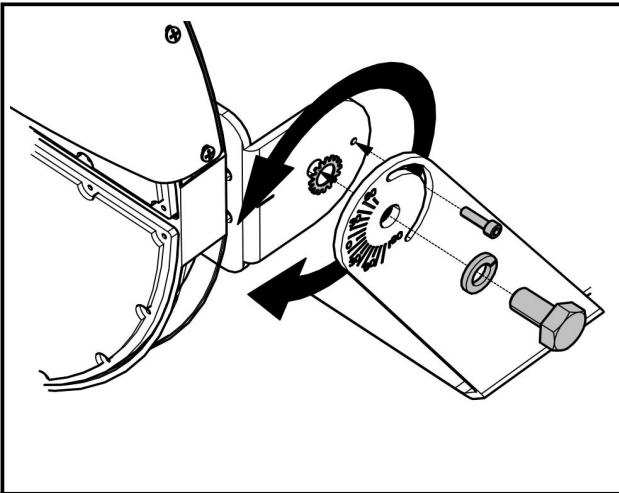

Step 1: Assemble the LED module to the arm brackets. Use the included bolt, lock washer, and tooth lock washer for mounting. Secure the tilt guide screw once assembled.

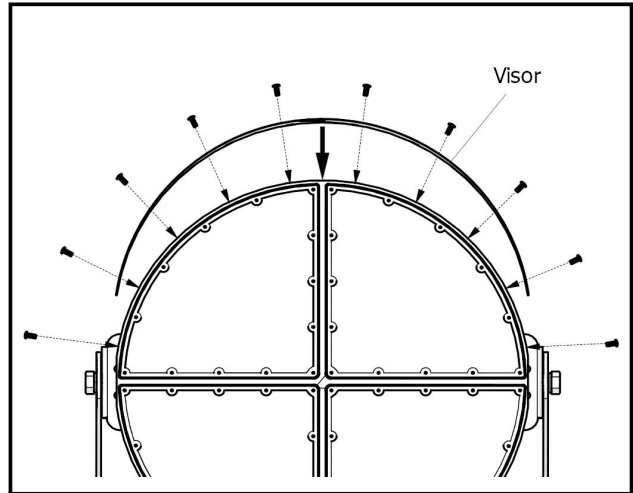

Step 2: Place the visor on top of the fixture and attach the visor with the provided screws.

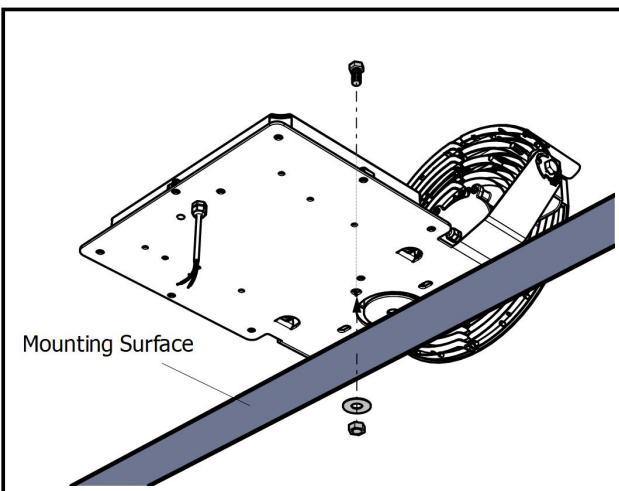

Step 3: Mount the fixture to the intended surface. Use the provided bolt, flat washer and nut to secure the fixture. Tighten to a minimum of 15 in-lb.

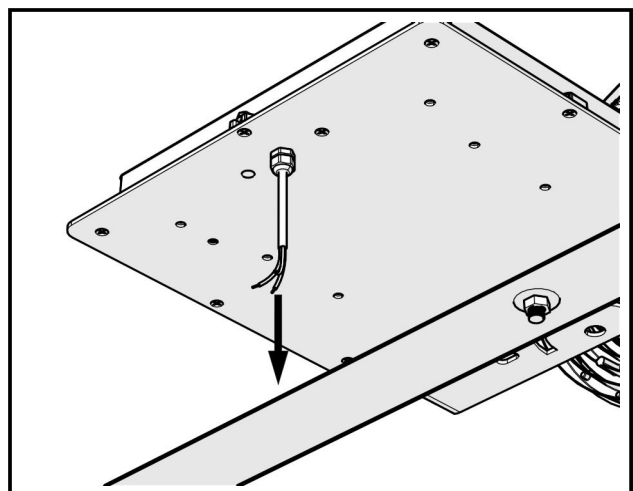

Step 4: Run the power cable to the junction box and wire according to the diagram on Page 3.

LED SPORTS LIGHT

Installation Guide

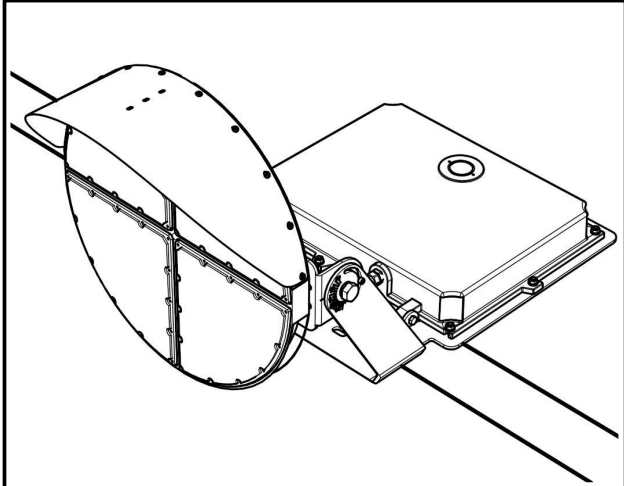

Step 5: Restore power and check that the fixture is working properly.

Electrical Wiring Diagram

