



# LED TrAILLiTE™

PART #: 77711

**WARNING: THE FAILURE TO FOLLOW THESE INSTRUCTIONS WHEN INSTALLING THE LED TRAILLITE MAY CAUSE ELECTRIC PROBLEMS IN YOUR VEHICLE WHICH COULD CAUSE VEHICLE DAMAGE, ELECTRICAL SYSTEM DAMAGE, FIRE, ELECTRICAL SHOCK, PERSONAL INJURY OR DEATH.**

**WARNING: DO NOT LOOK DIRECTLY INTO THE LED TRAILLITE. DO NOT DRIVE OR POSITION YOUR VEHICLE NEAR ONCOMING TRAFFIC WHEN THE LED TRAILLITE IS POWERED ON – DOING SO MAY RESULT IN VISION IMPAIRMENT AND OR VEHICULAR COLLISION. THE INTENDED USE OF THE LED TRAILLITE IS TO PROVIDE EXTERIOR AUXILIARY LIGHTING FOR OFF ROAD USE ONLY. THIS PRODUCT IS NOT DOT APPROVED.**

YOU MUST CONSULT YOUR VEHICLE OWNER'S MANUAL TO DETERMINE THE LOCATION OF AIRBAG SENSORS BEFORE INSTALLATION. THE MANUFACTURER OR THE RETAILER IS NOT RESPONSIBLE FOR INFLATION OF AIRBAGS OR DAMAGE TO AIRBAG SENSORS DUE TO THE INSTALLATION OF THIS PRODUCT.

### INSTALLATION GUIDELINE

**WARNING: SAFETY GLASSES MUST BE USED WHEN INSTALLING THIS PRODUCT.**

LED TrAILLiTE is an exterior auxiliary light designed to provide auxiliary lighting while driving off road. LED TrAILLiTE has a distinct amperage draw below in the installation instructions. If you are not confident in your ability to install the LED TrAILLiTE please consult a licensed mechanic.

LED TrAILLiTE has specific voltage and amperage ratings for power input and amperage draw. ENSURE THESE RATINGS ARE FOLLOWED. The LED TrAILLiTE must be installed in a properly functioning vehicle electrical system. Do not install this product in a malfunctioning vehicle electrical system.

Select a mounting location that will not obstruct the operation of any instruments.

Clean mounting surfaces before installing units using water or a 50/50 mix of water and rubbing alcohol.

Before permanently mounting to vehicle, test fit to ensure wiring is long enough to be safely installed and does not obstruct any operating functions of the vehicle. These lights should not be installed where their operation hinders the visibility of the driver or other drivers

**WARNING: DURING OPERATION LIGHTING UNITS CAN GET HOT - DO NOT TOUCH WHILE OPERATIONAL OR WITHIN 30 MINUTES OF POWERING DOWN.**

Before disconnecting battery terminals, please check your owner's manual for proper procedure.

## GET STARTED

### WARNING



BE SURE TO USE SAFETY GLASSES AT ALL TIMES WHEN INSTALLING THIS PRODUCT.

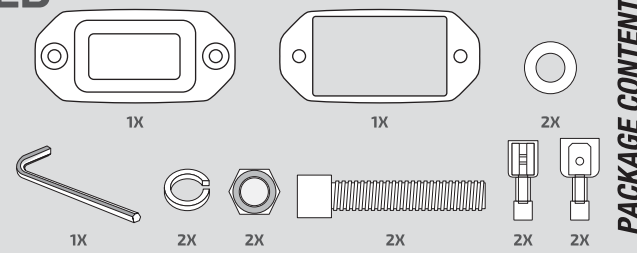

PACKAGE CONTENTS

## 1. SUGGESTED PLACEMENT

TYPICAL / SUGGESTED MOUNTING LOCATIONS:

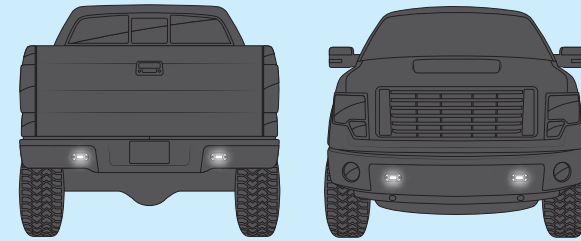

## 2. MOUNTING

USING THE INCLUDED GASKET AS A TEMPLATE MARK THE AREA YOU WISH TO FLUSH MOUNT THE LIGHT.

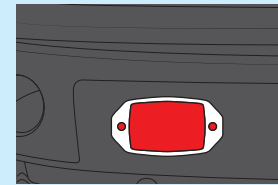

USING GASKET AS TEMPLATE

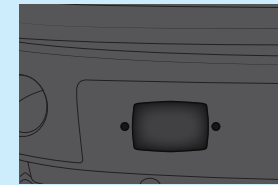

MODIFICATION

BEFORE ANY DRILLING OR MODIFICATION HAS TAKEN PLACE TEST FIT TO ENSURE THE UNIT OR WIRING WILL NOT INTERFERE WITH ANY VEHICLE FUNCTIONS

## 3. ASSEMBLY

ONCE THE MOUNTING HOLES HAVE BEEN MADE:

A) RUN THE WIRE THROUGH THE HOLE AND MOUNT THE UNIT FLUSH TO THE SURFACE

B) THREAD THE BOLTS THROUGH THE MOUNTING HOLES AND SECURE THE UNIT TO THE SURFACE USING THE WASHER, LOCK WASHER AND NUT

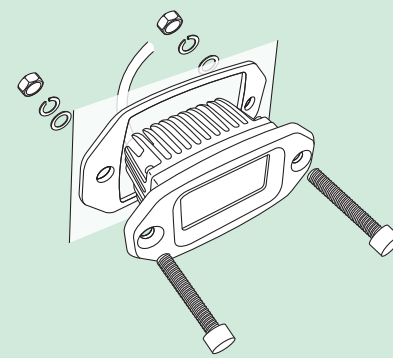

## 3. WIRING

(SEE FIGURE 1 FOR OPTIONAL RELAY WIRING DIAGRAM)

POWER REQUIREMENTS	5A @ 12V DC	2.5A @ 24V DC
ENSURE POWER SOURCE IS CAPABLE – SEE POWER RATINGS AND RESTRICTIONS. COMPATIBLE WITH SWITCHES THAT WILL SUPPORT POWER REQUIREMENTS OF 5A @ 12V DC / 2.5A @ 24V DC		

A) ATTACH POSITIVE WIRE SECURELY TO A 12-24V FUSED POWER SOURCE. EXTENSION OF THE WIRING MAY BE NECESSARY DEPENDING ON LOCATION OF THE UNIT RELATIVE TO THE POWER SOURCE. THE UNIT CAN BE WIRED INTO A SWITCH THAT WILL SUPPORT THE 5A DRAW AT 12V DC / 2.5A DRAW AT 24V DC.

B) ATTACH BLACK GROUND WIRE TO A SAFE, CLEAN GROUND LOCATION. EXAMPLE OF CLEAN GROUND LOCATION: CHASSIS BOLT OR FRAME BOLT.

ENSURE ALL WIRING IS SECURE AND SAFELY ROUTED AWAY FROM ANY HEAT SOURCES AND MOVING PARTS

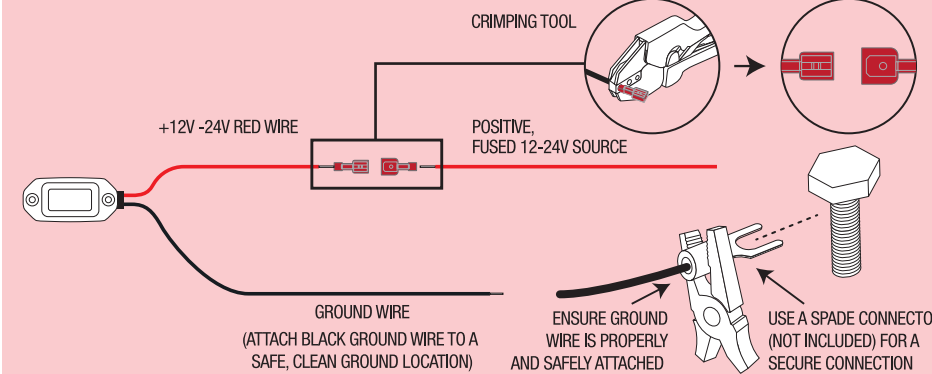

Problems? We can solve them!  
1-800-387-3217 - feedback@alpena.ca

## FIGURE 1. FULL WIRING DIAGRAM

### InstallKit Dual

Used for Demonstration, not included.  
Item #77631

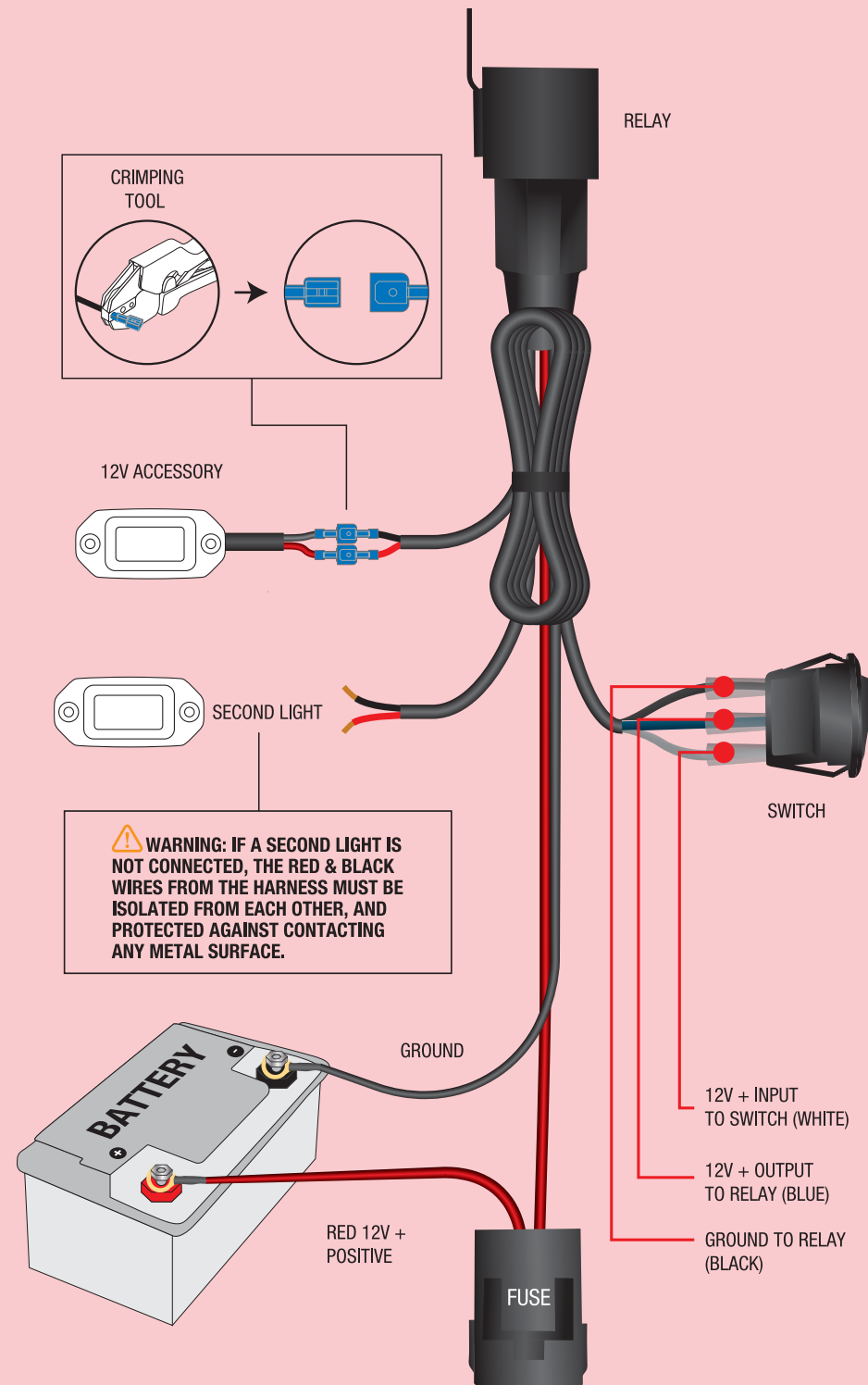

**WARNING: IF A SECOND LIGHT IS NOT CONNECTED, THE RED & BLACK WIRES FROM THE HARNESS MUST BE ISOLATED FROM EACH OTHER, AND PROTECTED AGAINST CONTACTING ANY METAL SURFACE.**

### ALPENA® LIMITED WARRANTY

This Limited Warranty covers defects in materials or workmanship of this product for one (1) year from the date of purchase. Normal wear and tear over time are not product defects. Product problems caused by not following the product instructions, abuse, misuse, alteration, accident and/or use beyond the product's intended purpose are not covered. This warranty is valid for the original owner and is not transferable. Proof of purchase is required.

Any implied warranties and conditions, such as merchantability and fitness for a particular purpose are hereby excluded, or if not excludable under law, are limited to one (1) year period. Some jurisdictions do not allow limitations on how long an implied warranty lasts, so this limitation may not apply to you

NO INCIDENTAL, CONSEQUENTIAL OR SPECIAL DAMAGES ARE RECOVERABLE. SOME JURISDICTIONS DO NOT ALLOW THE EXCLUSION OF INCIDENTAL, CONSEQUENTIAL OR SPECIAL DAMAGES, SO THE ABOVE LIMITATION OR EXCLUSION MAY NOT APPLY TO YOU. THIS WARRANTY GIVES YOU SPECIFIC LEGAL RIGHTS AND YOU MAY HAVE OTHER RIGHTS WHICH VARY DEPENDING ON THE JURISDICTION.

We will replace any product we determine to be defective provided you follow our product return directions. Please note that replacement product may not be exact due to style changes to our products. We will cover the mailing expense to send you a replacement product. However, mailing costs to return to us the original product which is claimed to be defective must be paid by you. If a replacement product is not available at the time you submit your warranty request, we will issue a credit.

For warranty service, please see below.

Problems? We can solve them!  
1-800-387-3217  
feedback@alpena.ca  
www.alpena.ca

