



LED Rover HD™

PART #: 77678

WARNING: THE FAILURE TO FOLLOW THESE INSTRUCTIONS WHEN INSTALLING THE LEDROVER HD MAY CAUSE ELECTRIC PROBLEMS IN YOUR VEHICLE WHICH COULD CAUSE VEHICLE DAMAGE, ELECTRICAL SYSTEM DAMAGE, FIRE, ELECTRICAL SHOCK, PERSONAL INJURY OR DEATH.

WARNING: DO NOT LOOK DIRECTLY INTO THE LEDROVER HD. DO NOT DRIVE OR POSITION YOUR VEHICLE NEAR ONCOMING TRAFFIC WHEN THE LEDROVER HD IS POWERED ON – DOING SO MAY RESULT IN VISION IMPAIRMENT AND OR VEHICULAR COLLISION. THE INTENDED USE OF THE LEDROVER HD IS TO PROVIDE EXTERIOR AUXILIARY LIGHTING FOR OFF ROAD USE ONLY. THIS PRODUCT IS NOT DOT APPROVED.

YOU MUST CONSULT YOUR VEHICLE OWNER'S MANUAL TO DETERMINE THE LOCATION OF AIRBAG SENSORS BEFORE INSTALLATION. THE MANUFACTURER OR THE RETAILER IS NOT RESPONSIBLE FOR INFLATION OF AIRBAGS OR DAMAGE TO AIRBAG SENSORS DUE TO THE INSTALLATION OF THIS PRODUCT.

INSTALLATION GUIDELINE

WARNING: SAFETY GLASSES MUST BE USED WHEN INSTALLING THIS PRODUCT.

LEDRover HD is an exterior auxiliary light designed to provide auxiliary lighting while driving off road. LEDRover HD has a distinct amperage draw below in the installation instructions. If you are not confident in your ability to install the LEDRover HD please consult a licensed mechanic.

LEDRover HD has specific voltage and amperage ratings for power input and amperage draw. ENSURE THESE RATINGS ARE FOLLOWED. The LEDRover HD must be installed in a properly functioning vehicle electrical system. Do not install this product in a malfunctioning vehicle electrical system.

Select a mounting location that will not obstruct the operation of instruments.

Clean mounting surfaces before installing units using water or a 50/50 mix of water and rubbing alcohol.

Before permanently mounting to vehicle, test fit to ensure wiring is long enough to be safely installed and does not obstruct any operating functions of the vehicle. These lights should not be installed where their operation hinders the visibility of the driver or other drivers

WARNING: DURING OPERATION LIGHTING UNITS CAN GET HOT - DO NOT TOUCH WHILE OPERATIONAL OR WITHIN 30 MINUTES OF POWERING DOWN.

Before disconnecting battery terminals, please check your owner's manual for proper procedure.

GET STARTED

WARNING



BE SURE TO USE SAFETY GLASSES AT ALL TIMES WHEN INSTALLING THIS PRODUCT.

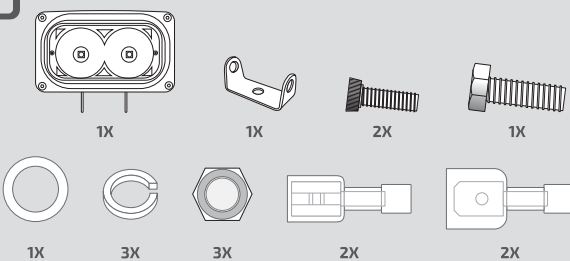

PACKAGE CONTENTS

1. ASSEMBLY

ASSEMBLE BRACKET.

- A) INSERT LARGE BOLT INTO THE BOTTOM OF THE BRACKET.
- B) SLIDE THE OPEN ENDS OVER THE BODY OF THE LIGHT TO MATCH THE BRACKET
- C) SECURE THE MOUNTING BRACKET WITH THE LOCK WASHER AND SHORT SCREW AS SHOWN ON BOTH SIDES
- D) LOOSELY TIGHTEN SIDE MOUNTING HARDWARE UNTIL LIGHT IS MOUNTED.

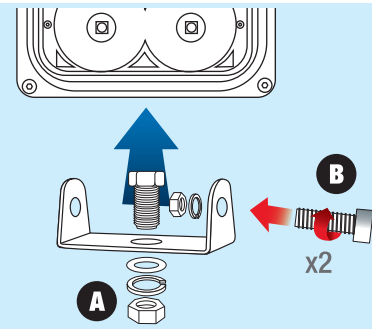

2. MOUNTING

MOUNT THE UNIT TO THE DESIRED MOUNTING LOCATION. IT IS RECOMMENDED TO CLEAN THE SURFACE OF ALL CONTAMINANTS PRIOR TO DRILLING ANY HOLES OR MOUNTING.

- A) IF THE DESIRED SURFACE HAS AN ADEQUATE MOUNTING HOLE, PLACE THE UNIT FLUSH WITH THE SURFACE, THREADING THE MOUNTING BOLT IN THE BRACKET THROUGH THE HOLE AND THEN TIGHTEN WITH INCLUDED WASHERS AND NUT
- B) DRILL A 3/8" HOLE IN THE SELECTED MOUNTING LOCATION IF THERE IS NO EXISTING HOLE. PLACE THE UNIT FLUSH WITH THE SURFACE, THREADING THE MOUNTING BOLT IN THE BRACKET THROUGH THE HOLE AND THEN TIGHTEN WITH INCLUDED WASHERS AND NUT

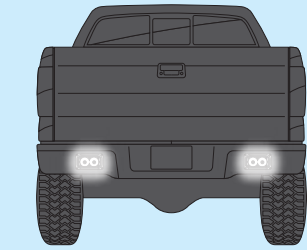

3. WIRING

(SEE FIGURE 1 FOR OPTIONAL RELAY WIRING DIAGRAM)

MAX POWER DRAW	2A @ 12V DC	1A @ 24V DC
----------------	-------------	-------------

ATTACH POSITIVE WIRE SECURELY TO A 12V DC POWER SOURCE. EXTENSION OF WIRING MAY BE NECESSARY. CAN BE WIRED INTO A RELAY HARNESS (SEE FIGURE 1) OR A SWITCH THAT WILL SUPPORT THE 2 AMP DRAW AT 12V DC.

ATTACH BLACK GROUND WIRE TO A SAFE, CLEAN GROUND LOCATION SUCH AS A CHASSIS GROUND POINT

ENSURE ALL WIRING IS SECURE AND SAFELY ROUTED AWAY FROM ANY HEAT SOURCES AND MOVING PARTS

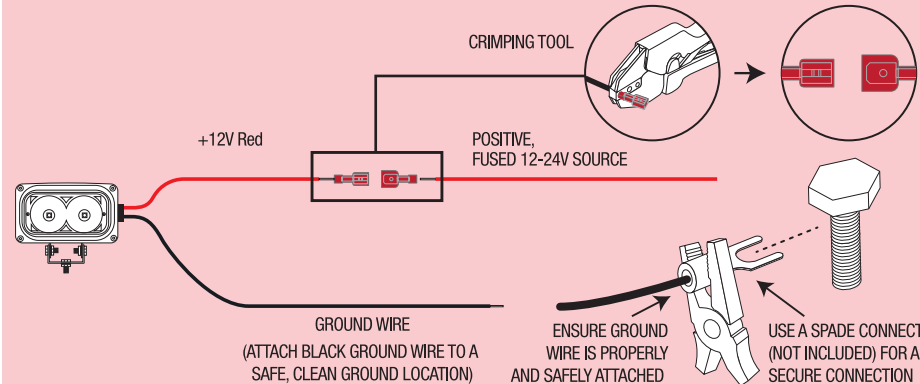

4. AIMING & OPERATION

- A) ADJUST THE ANGLE OF THE LIGHT BY PIVOTING THE LIGHT ON IT'S MOUNT (SIDE MOUNT BOLTS MAY NEED TO BE LOOSENED)
- B) WHEN DESIRED LIGHT ANGLE IS ACHIEVED, TIGHTEN BOTH SIDE BOLTS AS WELL AS THE SURFACE MOUNTING BOLT

NOTE: TIGHTEN ALL MOUNTING HARDWARE BEFORE DRIVING THE VEHICLE AND CHECK TIGHTNESS AFTER 50 MILES OR 3 DAYS OF DRIVING

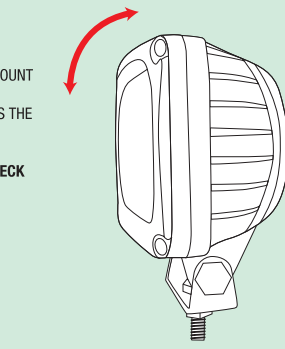
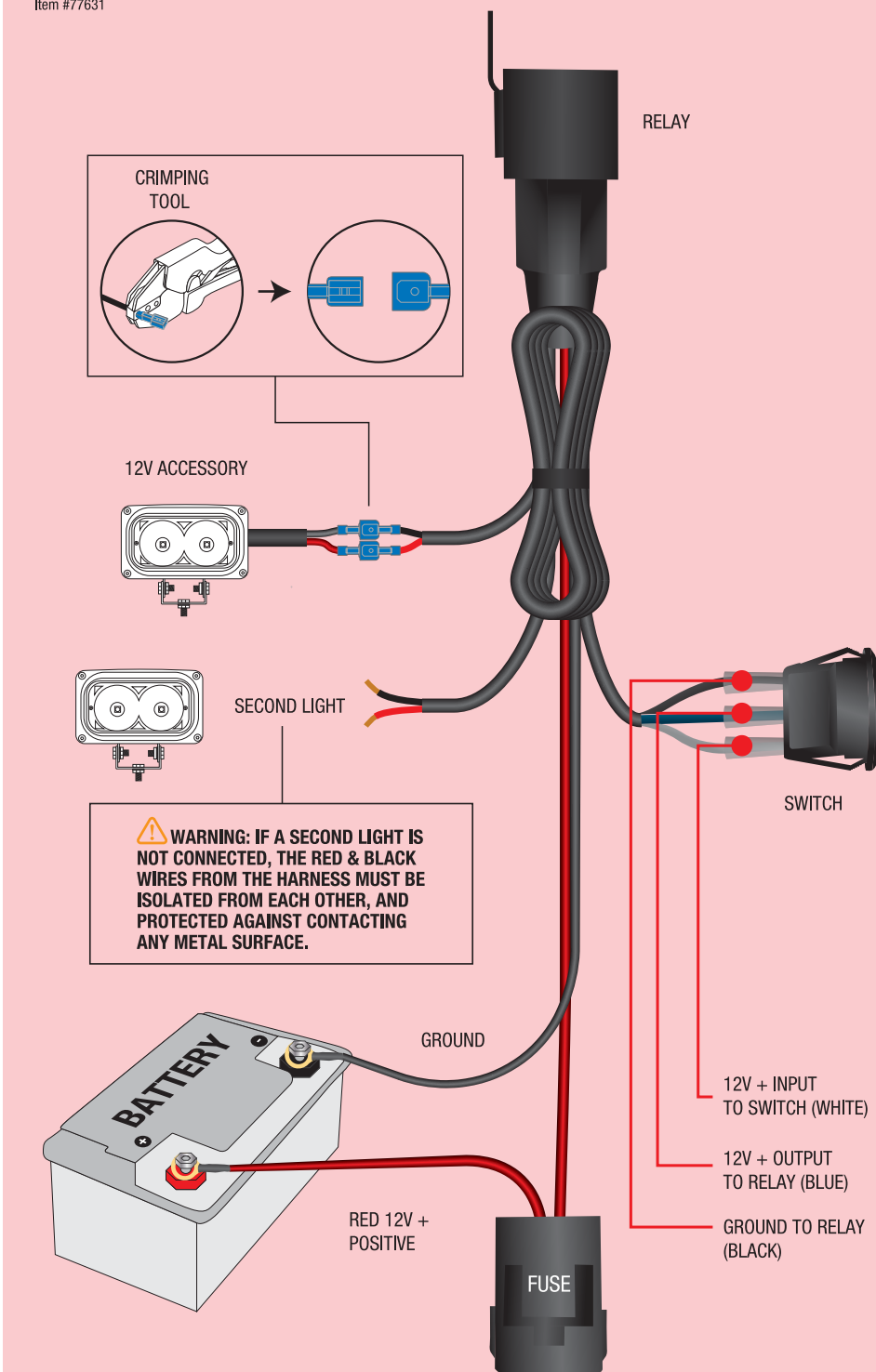

FIGURE 1. FULL WIRING DIAGRAM

INSTALLKIT DUAL

Used for Demonstration, not included. Item #77631



ALPENA® LIMITED WARRANTY

This Limited Warranty covers defects in materials or workmanship of this product for one (1) year from the date of purchase. Normal wear and tear over time are not product defects. Product problems caused by not following the product instructions, abuse, misuse, alteration, accident and/or use beyond the product's intended purpose are not covered. This warranty is valid for the original owner and is not transferable. Proof of purchase is required.

Any implied warranties and conditions, such as merchantability and fitness for a particular purpose are hereby excluded, or if not excludable under law, are limited to one (1) year period. Some jurisdictions do not allow limitations on how long an implied warranty lasts, so this limitation may not apply to you

NO INCIDENTAL, CONSEQUENTIAL OR SPECIAL DAMAGES ARE RECOVERABLE. SOME JURISDICTIONS DO NOT ALLOW THE EXCLUSION OF INCIDENTAL, CONSEQUENTIAL OR SPECIAL DAMAGES, SO THE ABOVE LIMITATION OR EXCLUSION MAY NOT APPLY TO YOU. THIS WARRANTY GIVES YOU SPECIFIC LEGAL RIGHTS AND YOU MAY HAVE OTHER RIGHTS WHICH VARY DEPENDING ON THE JURISDICTION.

We will replace any product we determine to be defective provided you follow our product return directions. Please note that replacement product may not be exact due to style changes to our products. We will cover the mailing expense to send you a replacement product. However, mailing costs to return to us the original product which is claimed to be defective must be paid by you. If a replacement product is not available at the time you submit your warranty request, we will issue a credit.

For warranty service, please see below.

Problems? We can solve them!
1-800-387-3217
feedback@alpena.ca
www.alpena.ca



Problems? We can solve them!
1-800-387-3217 - feedback@alpena.ca