



# FREE STANDING CONTACTLESS BOTTLE FILLER WITH QUASAR UVC-LED

Stainless Steel Free Standing Electronic Bottle Filler

## Features:

- QUASAR UVC-LED Water Treatment at the dispense point inactivates up to 99.99% of microorganisms
- UVC-LED cycles on periodically to keep the dispense point sanitized between dispenses
- If QUASAR UVC-LED stops working, then water dispensing is stopped until the QUASAR is repaired.
- Brushed stainless steel cabinet
- 43.5 inch point of dispense height from ground
- High flow output of 1.1 gallons per minute (4 liters) for faster fill up
- Molded plastic components are infused with FRESHIELD antimicrobial to help fight against degradation caused by the growth of bacteria
- Contactless electronic sensor allows for activation with 20 second auto shut-off
- Built in drain – no drip tray to empty
- Programmable shut-off timer to prevent unintended continuous dispense
- Certified to NSF/ANSI Standard 61 and 372
- UL listed
- 5-year limited warranty

## Optional Refrigeration System:

- Refrigerated model delivers 10 gallons of chilled drinking water per hour
- Non-refrigerated model delivers ambient drinking water

## Optional Filter:

- VersaFilter III and Remedi filters for lead, cyst, chlorine, taste and odor reduction
- Mounted inside cabinet with easy access from front panel



# PRODUCT DIMENSIONS

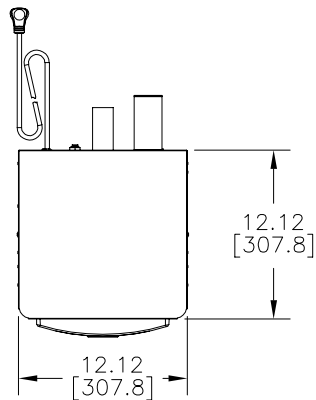

PLAN VIEW

ALL DIMENSIONS ARE IN INCHES.

DIMENSIONS IN BRACKETS [ ] ARE IN MILLIMETERS.

ALLOW 4" [102] FOR VENTILATION AT THE REAR OF THE WATER COOLER AND THE SIDES IF SET IN AN ALCOVE OR NEAR A CORNER.

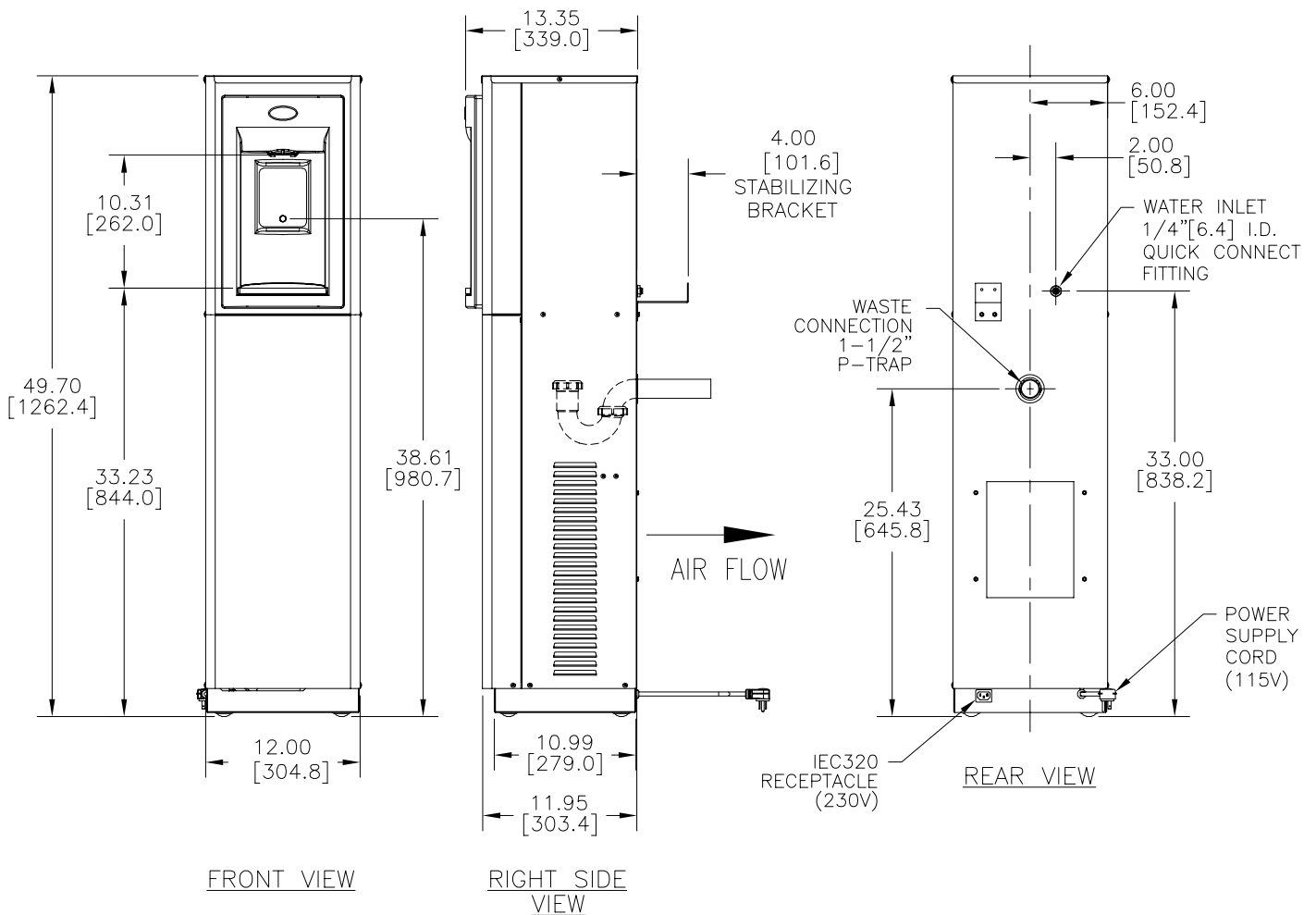

FRONT VIEW

RIGHT SIDE VIEW

REAR VIEW

OASIS INTERNATIONAL

[www.oasiscoolers.com](http://www.oasiscoolers.com)

222 East Campus View Blvd.  
Columbus, OH 43235

1-800-646-2747