

linärie

PAU

63L Built-in Oven
LYBO63MF

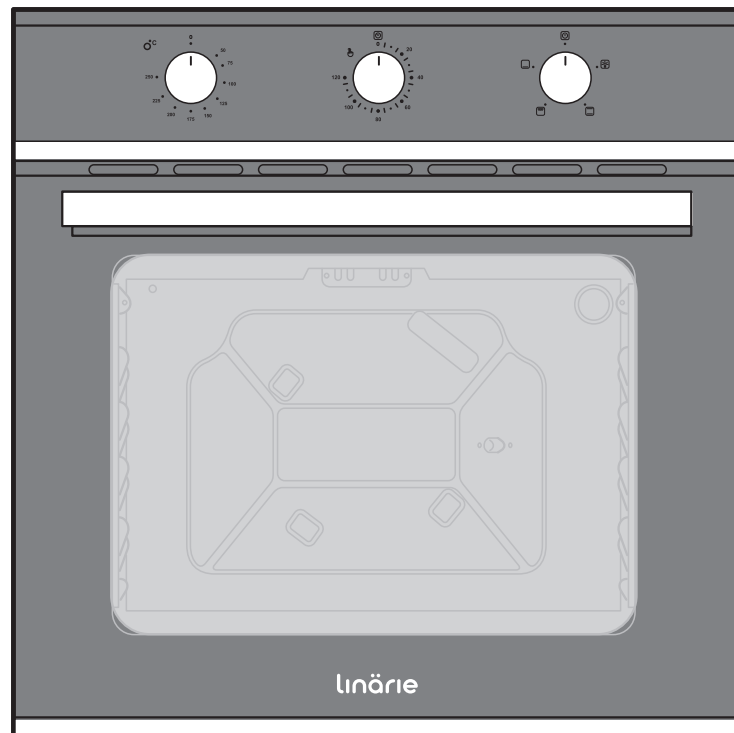

EN Operation, Installation
& Instruction Manual

www.linärie.com.au

Register
your
product
online

CONGRATULATIONS

Congratulations and thank you for choosing Linärie to introduce a new comfort of cooking in your home. We are sure you will find your new appliance a pleasure to use and a great asset to your kitchen.

This appliance complies with all relevant safety requirements in Australia. Inappropriate use can, however, lead to personal injury and damage to property.

In order to operate the unit correctly and safely, please read this instruction manual carefully before installation and usage. This user manual which provides you with all required instructions related to safety, installation, use and maintenance of the appliance.

For future reference, please store this booklet in a safe place and ensure that all users are familiar with the contents. Pass them on to any future owner of the appliance.

Record Model & Serial Number

Model

Serial Number

Register your product www.linarie.com.au

IMPORTANT

Adherence to the directions for use in this manual is extremely important for health and safety. Failure to strictly adhere to the requirements in this manual may result in personal injury, property damage and affect your ability to make a claim under Linärie's manufacturer's warranty provided with your product. Products must be used, installed and operated in accordance with this manual. You may not be able to claim on Linärie's manufacturer's warranty in the event that your product fault is due to failure to adhere this manual.

Correct Conditions of Use

- The appliance is intended for use in the home and similar environments only. It is not intended for commercial use.
- **Danger of fire:** do not store items on the cooking surface.
- A steam cleaner is not to be used.
- The appliance is not intended to be operated by means of an external timer or separate remote control system.
- Ensure that the appliance is switched off before replacing the lamp to avoid the possibility of electric shock. Regarding the instructions for installation and electric connection of the appliance, thanks to refer to the below paragraph of the manual.

 Linärie do not assume any liability for damage arising from non-adherence to these documents and from improper assembly. The electricity connection must be made by a qualified specialist. Installation must comply with the valid standards, regulations and laws. All safety and warning information and the operating and installation instructions must be complied with.

TABLE OF CONTENTS

1. General Information	3
1.1 Appliance information	3
2. General Safety Instructions	3
2.1 General safety information	3
2.2 Safety instruction - Installation	3
2.3 Correction use and Operation	3
3. Technical data sheet	4
3.1 SPECIFICATION	4
3.2 PARTS and PART LIST	4
4. Installation	5
5. Before using the oven for the first time	6
5.1 Slide-in racks Placement Warning	6
5.2 Heating up the oven	6
5.3 Energy saving tips	6
5.4 Cleaning accessories	6
6. Control panel	7
7. Program functions	7
7.1 CLOCK Setting	8
7.2 ALARM Setting	8
7.3 COOKING TIME Setting	8
7.4 COOKING END TIME Setting	8
7.5 AUTOMATIC PROGRAMMER Setting	8
7.6 Setting the child-proof lock (key lock)	8
8. Cooking knack	9
9. How to operate the oven	9
10. Baking and Grilling tips	10
Baking tips	
Grilling tips	
11. Cleaning and maintenance	11
12. Troubleshooting	13
13. Environmental tips	14
13.1 Disposal consideration	
13.2 Disposing of your old appliance	
14. Warranty and after sales	
14.1 Warranty	
14.2 After sales	
14.3 Replacement of spareparts	

Additional information on products, accessories, warranty, replacement parts and services can be found at www.linarie.com.au

1. GENERAL INFORMATION

1.1 Appliance Information

- A damaged appliance can be dangerous. If you find the appliance is damaged or marked, you must report it within 7 days if you wish to claim for damage/marks under the manufacturer's warranty. This does not affect your statutory rights. Do not use a damaged appliance.
- The manufacturer's warranty will be invalidated if the appliance is not repaired by a Linärie approved service technician.
- Faulty components must only be replaced by genuine Linärie spare parts. The manufacturer can only guarantee the safety of the appliance when Linärie replacement parts are used.
- If the power cord is damaged, it must only be replaced by a Linärie authorized service technician or suitably qualified electrician in order to avoid a hazard.
- Linärie cannot be held liable for noncompliance with these instructions, resulting from incorrect or improper use or operation.

2. GENERAL SAFETY INSTRUCTIONS

 The appliance complies with the stipulated safety requirements in Australia. The user is responsible for appliance cleaning and maintenance as well as its safe use. Improper use can lead to personal injury and damage to property.

2.1 General Safety Instructions

Children and People with Special Needs

WARNING

This appliance is not intended for use by persons (including children) with reduced physical, sensory or mental capabilities, or lack of experience and knowledge, unless they have been given supervision or instruction concerning use of the appliance by a person responsible for their safety.

- The appliance is NOT suitable for use by children without supervision.
- Young children should be supervised near the appliance to ensure they do not play with this appliance.
- Children may be able to wrap themselves in packing material or pull it over their heads with the risk of suffocation. Keep children away from any packing material.

Cleaning & Maintenance

The device must be cleaned regularly. Dirt can lead to damage or the buildup of odors. (See "Cleaning and maintenance" section).

- Always clean the appliance exactly as indicated in the operating instructions.
- Always ensure the appliance is switched off before cleaning or replacing parts.
- Clean the appliance immediately after any food spillage and the filter regularly to keep the appliance working efficiently.
- There is a risk of fire if cleaning is not carried out as described in these operating instructions.
- Make sure no water penetrates inside the device when cleaning. Do not use a steam cleaning appliance to clean this appliance. The steam could reach electrical components and cause a short circuit.
- In areas which may be subject to infestation by cockroaches or other vermin, pay particular attention to keeping the machine and its surroundings in a clean condition at all times. Any damage which may be caused by cockroaches or other vermin will not be covered by the machine warranty.

Unauthorized Modifications

Unauthorised modifications can cause the appliance to pose risks. Do not conduct any modifications to the appliance.

2.2 Safety Instructions - Installation

WARNING

The appliance must only be installed and assembled by trained specialists who are familiar with and comply with the standard national regulations and supplementary regulations of ventilation systems.

- In order to avoid any potential hazard, the installation instructions must be followed.
- Observe all regional regulations for the installation of ventilation systems.
- During installation, maintenance and repair work, the appliance must be disconnected from the mains electricity supply. It is only completely isolated from the electricity supply when:
 - the mains circuit breaker is switched off, or
 - it is switched off at the wall socket and the plug is withdrawn from the socket.
- Do not pull the mains connection cable but the mains plug to disconnect your appliance from the mains electricity supply.
- Do not connect the appliance to the mains electricity supply by a multi-socket unit or an extension lead.
- Extension leads are a fire hazard and do not guarantee the required safety of the appliance.
- Tampering with electrical connections or components and mechanical parts is highly dangerous to the user and can cause operational faults. Only open the housing as described in the instructions given in "Installation" and in the "Cleaning & Maintenance" sections of this booklet. Under no circumstances should any other parts of the housing be opened.
- **THIS APPLIANCE MUST BE PROPERLY EARTHED.** It is most important that this basic safety requirement is present and tested regularly and, where there is any doubt, the household wiring system should be inspected by a qualified electrician. Linärie cannot be held liable for noncompliance with these instructions, resulting from incorrect or improper use or operation.

2.3 Correction use and Operation

- For safety reasons, this appliance may only be used after it has been built in.
- Reliable and safe operation of this appliance can only be assured if it has been connected to the mains electricity supply.
- Before using the appliance, ensure that all packaging materials are removed from the appliance and make sure that the connection data on the data plate [voltage (V) and frequency (Hz)] indicated on the appliance corresponds to the voltage and frequency of the power supply in your household. Consult a qualified electrician if in doubt.
- DO NOT store or spray flammable materials in the appliance or near this appliance while it is in operation (e.g. aerosols).
- Cracks, fissures or fractures in the glass ceramic panels can damage the underlying electronics. Switch off and disconnect the appliance immediately.
- This appliance can become damaged when exposed to excessive heat.
 - When using this appliance, ensure that any burners in use are always covered by a pan. Switch the cooking zone off when a pan is removed, even for a short time.
 - Select a pan which is suitable for the size of the burner.
 - Regulate the flame so that it does not burn up the sides of the pan.
 - Avoid overheating the pan (e.g. when cooking with a wok).
- Always switch the appliance on when a cooking zone is in use, otherwise condensation may collect in the this appliance, which could cause corrosion.
- When cooking with oil or fat, chip pans and deep fat fryers etc., do not leave the pans unattended. Never leave an open grill unattended when grilling. Overheated oil and fat can ignite and could set the rangehood on fire.

3. TECHNICAL DATA SHEET

This appliance is only suitable for cooking food. Do not use it for other purposes, i.e. for storage purposes. Otherwise, it might lead to damage to the appliance or personal injury.

The standby power is about 0.5W when the power supply of the product is "off".

3.1 SPECIFICATION

Parameter	Value
Model	LYBO63MF
Power Supply Voltage	220-240V ~ 50Hz/ 60Hz
Dimensions (width, depth x height)	59.5 x 50.0 x 59.5
Capacity (L)	63L
Max. current	230V/ 16A

Parameter	Value
Top heating element	1000W
Grill heating element	1200W
Bottom heating element	1000W
Maximum power	2200W
Cooling fan	12W
Lamp	25W

3.2 PARTS and PART LIST

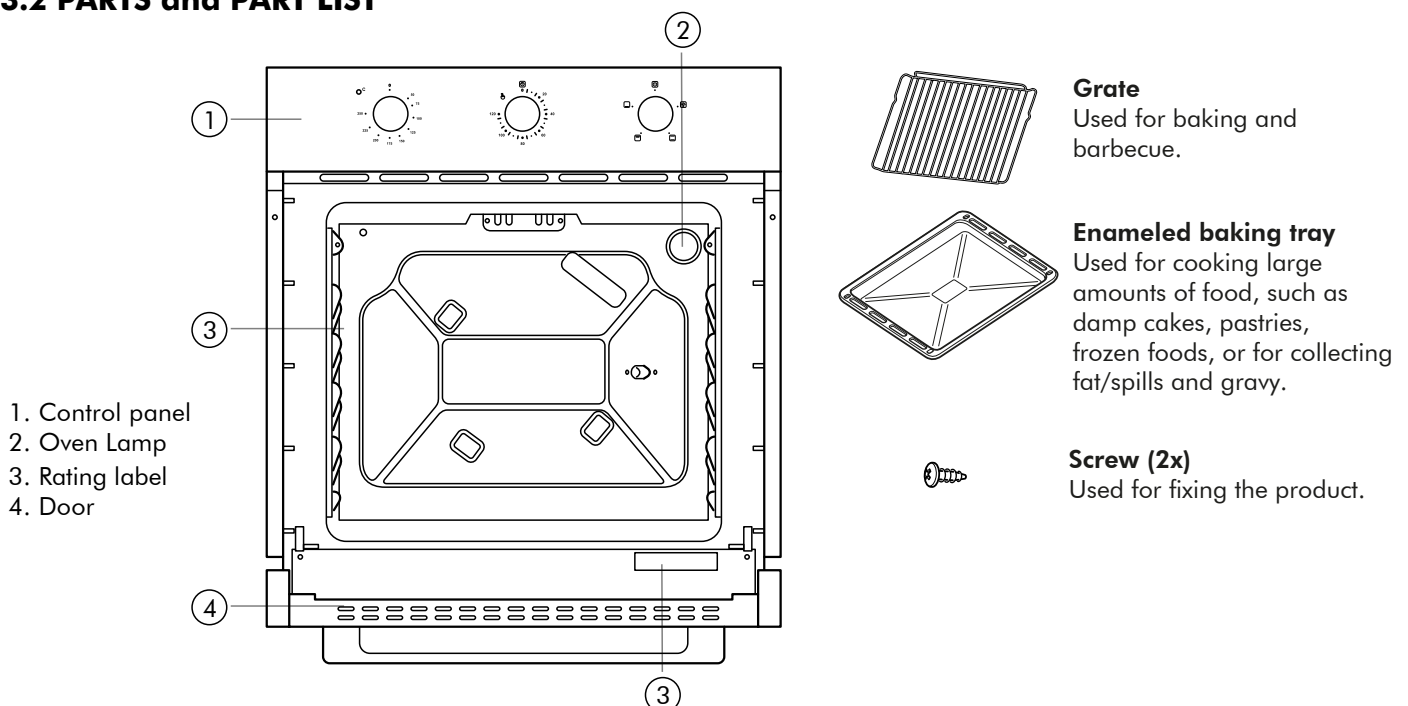

4. INSTALLATION

INSTALLATION NOTES

- The kitchen cover must be suitable to ensure that the oven works properly.
- The panel of kitchen equipment adjacent to the oven must be made of heat-resistant materials. Kitchen equipment made of plywood shall ensure that the glue can withstand a temperature of at least 120 degrees Celsius. When plastic or glue cannot withstand this temperature, the equipment will melt and deform.
- Once the oven is placed in the kitchen equipment, the electrical components must be completely insulated. This is a statutory safety requirement.
- All furnace covers must be firmly fixed in place and cannot be removed without using special tools.
- Remove the back of the kitchen equipment to ensure the full circulation of air around the oven.
- The oven rack must have at least 45 mm rear clearance.
- Because oven handle and sheet metal parts are easy to cut, installers need to wear gloves for installation.

ELECTRICAL CONNECTIONS

⚠ WARNING

- The wiring of oven must be equipped with all-pole disconnection device according to the wiring rules.
- After installing the appliance, it is necessary to have other methods to disconnect the power supply. The power supply is disconnected by a contactable plug or by a fixed wiring switch that meets the wiring requirements.

Important information

The appliance is designed to be permanently installed with a three-pin power cord and may only be connected by a licensed expert in accordance with the connection diagram. Only a qualified electrician who takes the relevant regulations into account may replace the power cord. Do not use multiple plugs, power strips or extensions. Overloading causes a risk of fire. If the connection is no longer accessible following installation, an all-pin isolating switch with a contact gap of at least 3mm must be provided.

FIXING THE OVEN

Two persons are required to assist in the installation of the oven. The oven base must be installed as shown below.

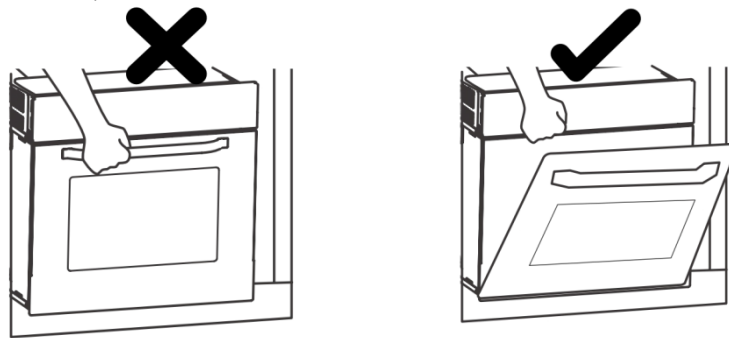

DIMENSIONS

Pay attention to the general dimensions required for installation.

- The oven can be installed in any cabinet with heat resistance.

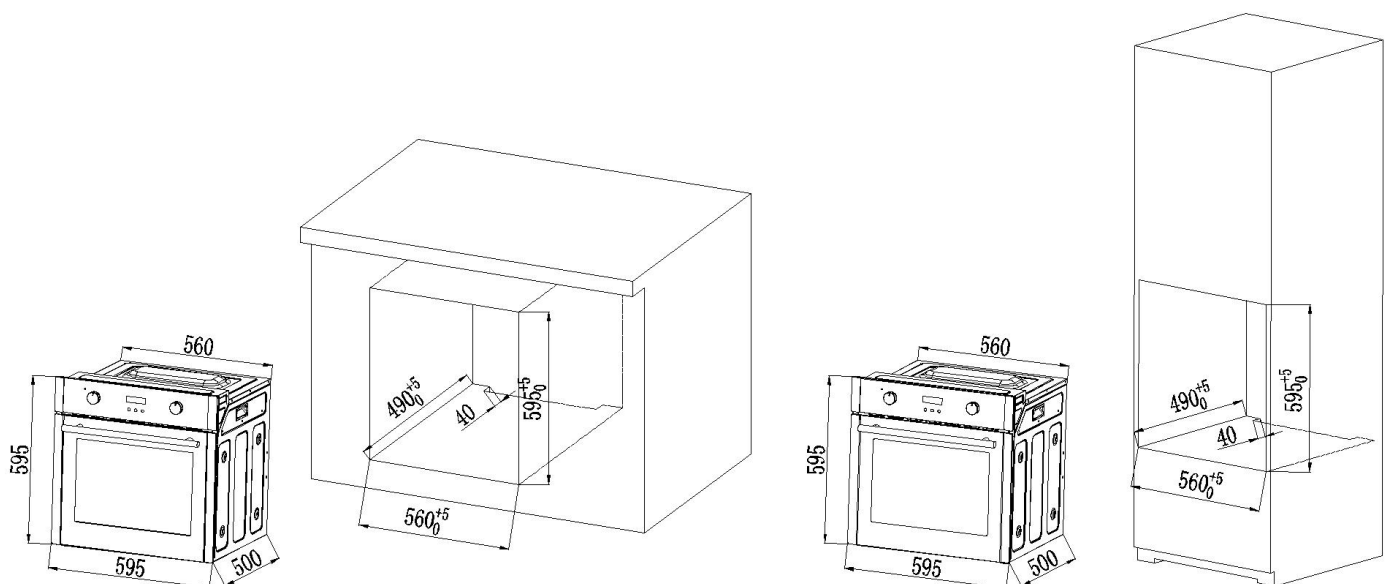

cont. installation

- 1 Slide the oven through the cabinet aperture, align and secure.

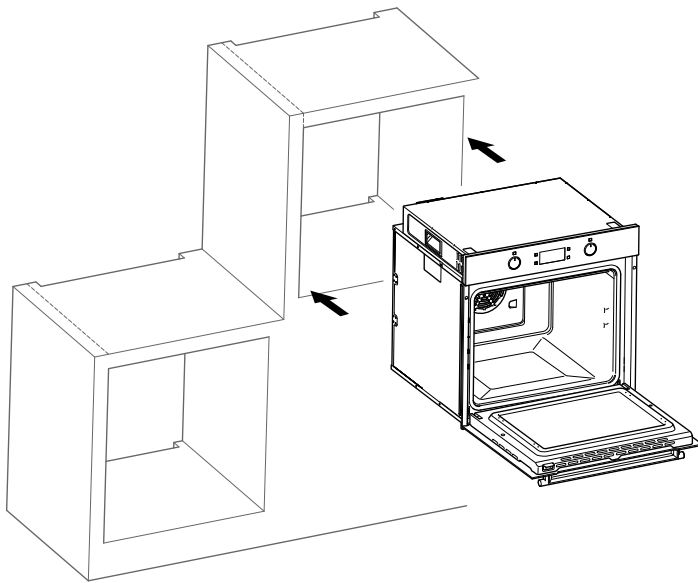

Oven image is for reference only.

- 2 Fix your oven with the 2 screws and washers as indicated in the image.

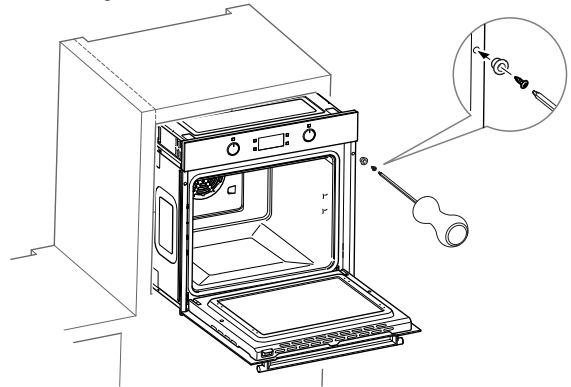

- 3 Final checking

1. Connect the appliance to the main electrical supply correctly and switch on the main supply.

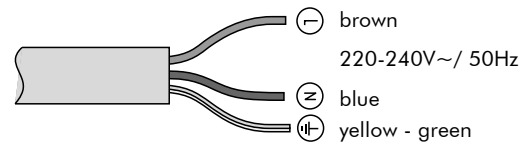

2. Check the appliance and its functions.

5. BEFORE USING THE OVEN FOR THE FIRST TIME

5.1 Slide-in racks Placement Warning

In order to ensure the safe use of the grate or tray, it is necessary to insert it in the right direction and place the slide-in racks correctly.

In addition, you can also refer to the level number displayed in the front of the oven when you open it. (There are five levels altogether.)

This ensures that food does not slip out of the back during careful removal from the grate or tray.

Before closing the oven door, make sure that the grate (baking tray) is in place and that the grate (baking tray) does not touch the glass inside the oven door.

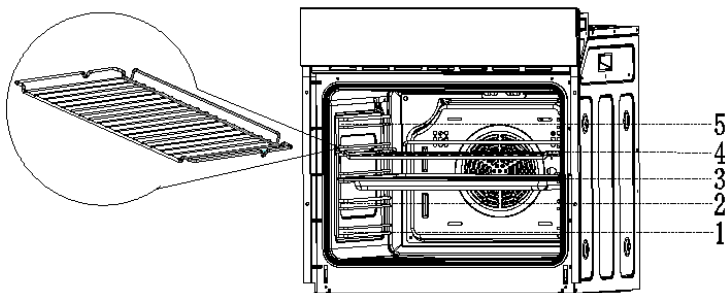

5.4 Cleaning the accessories

Before you use the accessories for the first time, clean it thoroughly with hot soapy water and a soft dish cloth.

5.2 Heating up the oven

To remove the new cooker smell, heat up the oven when it is empty and closed. An hour of top/ bottom heating at 240°C is ideal for this purpose. Ensure that no packaging remnants have been left in the cooking compartment.

- Use the function selector to set the top/ bottom heating.
- Set the temperature selector to 240°C. After an hour, switch off the oven. To do so, turn off the function selector to off position.



5.3 Energy saving tips

The following information will help you to use your appliance in an ecological way, and to save energy.



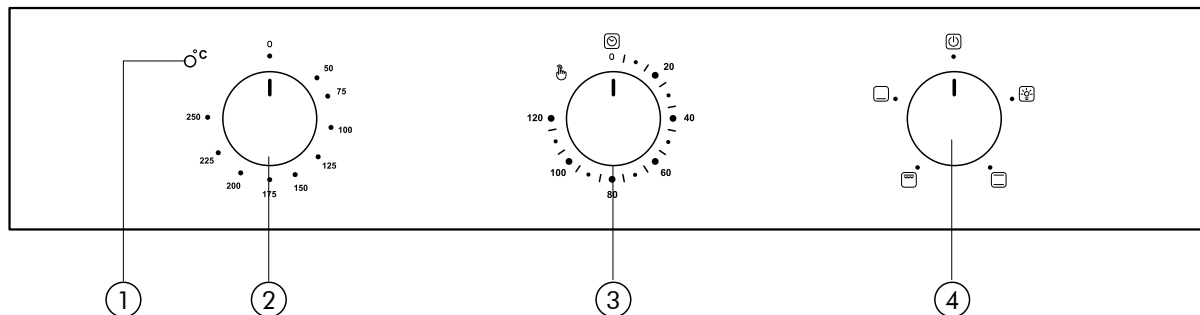

- Use dark coloured or enamel coated cookware in the oven since the heat transmission will be better.
- While cooking your dishes, perform a preheating operation if it is advised in the user manual or cooking instructions.
- Do not open the door of the oven frequently during cooking.
- Try to cook more than one dish in the oven at the same time, whenever possible. You can cook by placing two vessels on to the wire grill.
- Cook more than one dish one after another. The oven will already be hot.
- You can save energy by switching off your oven a few minutes before the cooking time. Do not open the oven door.
- Defrost frozen dishes before cooking them.

6. CONTROL PANEL











1. Indicator light
(indicates the heating process, i.e. the operation of one or more heating elements)
2. Temperature setting knob
 - Rotate the knob to select the desired temperature.
3. Timer setting knob
 - Rotate the knob to select the desired cooking time. When the set time is reached, the oven stops working. The bell rings and the lamp turns off automatically. The  in the timer setting knob is the stay on function, rotate counterclockwise to the , the oven stays working.
4. Function setting knob
 - Rotate the knob to select the desired function.

7. PROGRAM FUNCTIONS

Icons	Function Description
	Lamp Users can observe the cooking progress without opening the door, but they need to start the setting function and then the lamp will turn on.
	Top and bottom heat The top and bottom work together, and can be used for routine cooking operations.
	Double grilling The upper inner ring heating element and the outer ring heating element can work at the same time. The temperature can be set in the range of 50°C to 250°C.
	Bottom heat The concealed element at the bottom of the oven provides more concentrated heat without browning. This is suitable for slow cooking dishes, such as crisp casseroles, stews, pastries and pizza.

8. COOKING KNACK

Food	Weight (kg)	Level	Function Setting	Temperature in °C	First Face(minutes)	Second Face(minutes)	Accessory
Biscuit	0.5	3		200	10-15	-	baking tray
Sandwich	0.2	3		180	15-20	-	grate
Swiss Roll	0.2	3		180	10-18	-	baking tray
Small cake	0.3-0.4	3		185	20-25	-	baking tray
Sponge cake	0.5	3		175	30-35	-	grate
Pizza	0.35	3		200	10	-	baking tray
Apple pie	1.2	3		185	50-60	-	grate
Toast	9pcs	5		240	1-2	-	grate
Hamburger	1	5		240	10-20	5-10	baking tray

9. HOW TO OPERATE THE OVEN

General information on baking, roasting and grilling and risk of scalding by hot steam!
Take care when opening the oven door as steam may get out.

Normal Suggestions

- We suggest to preheat the oven before the food is put into the oven.
- Normally, it is impossible to shorten the cooking time by increasing the temperature (food may be well cooked outside, but not yet inside).
- If cooking is done on a multi-layer grill, we suggest using a Conventional + fan function so that uniform cooking can be achieved at all heights.
- In order to achieve the best cooking effect, we suggest that the suitable ware should be placed in the center of the grill or tray.
- In order to prevent the formation of excessive condensation beads on the inner glass, after cooking, hot food should not be placed in the oven for a long time.

Suggestions on cake and biscuits cooking

- Dark metal molds can absorb heat better when baking cakes.
- Temperature and cooking time depend on the quality and consistency of the mixture.
- To check the cake is ripe or not, at the end of cooking time, insert the metal pole to the top of the cake and then withdraw. If the batter does not stick to the metal pole, the cake is ripe.
- If the cake collapses when it comes out of the oven, the next you can extend the time appropriately, if necessary, can also be reduced by about 10°C for baking.

Suggestions on meat cooking

- The cooking time of food, especially meat, varies with the thickness and quality of the meat and the taste of the user.
- We suggest using meat thermometers when cooking meat. (The thermometer is not supplied with the oven.)
- If necessary, food can be wrapped in aluminum foil for cooking to make the food more tender.

10. BAKING and GRILLING TIPS

Baking tips

- How to establish whether sponge cake is baked through. Approximately 10 minutes before the end of the baking time specified in the recipe, stick a cocktail stick into the cake at the highest point. If the cocktail stick comes out clean, the cake is ready.
- The cake collapses. Use less fluid next time or set the oven temperature 10 degrees lower. Observe the specified mixing times in the recipe.
- The cake has risen in the middle but is lower around the edge. Do not grease the sides of the spring form cake tin. After baking, loosen the cake carefully with a knife.
- The cake goes too dark on top. Place it lower in the oven, select a lower temperature and bake the cake for a little longer.
- The cake is too dry. When it is done, make small holes in the cake using a cocktail stick. Then drizzle fruit juice or an alcoholic beverage over it. Next time, select a temperature 10 degree higher and reduce the baking time.
- The bread or cake (e.g. cheesecake) looks good, but is soggy on the inside (sticky, streaked with water). Use slightly less fluid next time and bake for slightly longer at a lower temperature. For cakes with a moist topping, bake the base first. Sprinkle it with almonds or bread crumbs and then place the topping on top. Please follow the recipe and baking times.
- The cake is unevenly browned. Select a slightly lower temperature to ensure that the cake is baked more evenly. Bake delicate pastries on one level using Top/bottom heating. Protruding greaseproof paper can affect the air circulation. For this reason, always cut greaseproof paper to fit the baking tray.
- The bottom of a fruit cake is too light. Place the cake one level lower the next time.
- The fruit juice overflows. Next time, use the deeper universal pan, if you have one.
- Small baked items made out of yeast dough stick to one another when baking. There should be a gap of approx. 2 cm around each item. This gives enough space for the baked items to expand well and turn brown on all sides.
- You were baking on several levels. The items on the top baking tray are darker than that on the bottom baking tray. Always use 3D hot air to bake on more than one level. Baking trays that are placed in the oven at the same time will not necessarily be ready at the same time.
- Condensation forms when you bake moist cakes. Baking may result in the formation of water vapor, which escapes above the door. The steam may settle and form water droplets on the control panel or on the fronts of adjacent units. This is a natural process.

Grilling tips

- When grilling, preheat the oven for approx. 4 minutes, before placing the food into the cooking compartment. Always grill with the oven door closed.
- As far as possible, the pieces of food you are grilling should be of equal thickness. This will allow them to brown evenly and remain succulent and juicy.
- Turn the food you are grilling after 2/3 of the time.
- Do not add salt to steaks until they have been grilled.
- Add in a little liquid if the meat is lean. Cover the base of the ovenware with approx. 1/2 cm of liquid.
- Add liquid generously for pot roasts. Cover the base of the ovenware with approx. 1-2 cm of liquid.
- Place the food to be grilled directly on the wire rack. If you are grilling a single piece, the best results are achieved by placing it in the centre of the wire rack. The universal pan should also be inserted at level 1. The meat juices are collected in the pan and the oven is kept cleaner.
- When grilling, do not insert the baking tray or universal pan at level 4 or 5. The high heat distorts it and the cooking compartment can be damaged when removing it.
- The grill element switches on and off continually. This is normal. The grill setting determines how frequently this will happen.
- When the roast is ready, turn off the oven and allow it to rest for an additional 10 minutes. This allows better distribution of the meat juices.
- For roast pork with a rind, score the rind in a crossways pattern, then lay the roast in the dish with the rind at the bottom.
- Place whole poultry on the lower wire rack breast-side down. Turn after 2/3 of the specified time.
- For duck or goose, pierce the skin on the underside of the wings. This allows the fat to run out.
- Turn the pieces of fish after 2/3 of the time, whole fish does not have to be turned. Place the whole fish in the oven in its swimming position with its dorsal fin facing upwards. Placing half a potato or a small ovenproof container in the stomach cavity of the fish will make it more stable.
- How to tell when the roast is ready. Use a meat thermometer (available from specialist shops) or carry out a "spoon test". Press down on the roast with a spoon. If it feels firm, it is ready. If the spoon can be pressed in, it needs to be cooked for a little longer.
- The roast is too dark and the crackling is partly burnt. Check the shelf height and temperature.
- The roast looks good but the juices are burnt. Next time, use a smaller roasting dish or add more liquid.
- The roast looks good but the juices are too clear and watery. Next time, use a larger roasting dish and use less liquid.
- Steam rises from the roast when basted. This is normal and due to the laws of physics. The majority of the steam escapes through the steam outlet. It may settle and form condensation on the cooler switch panel or on the fronts of adjacent units.

11. CLEANING & MAINTENANCE

i GENERAL INFORMATION

- Allow the appliance to cool down completely before cleaning and maintenance.
- The surfaces and controls are susceptible to scratches and abrasion. Please observe the following cleaning instructions.

- The oven should be thoroughly cleaned before it is operated for the first time and after each use. This will avoid residual food stuffs becoming baked on the oven cavity. After residues have been baked on several times, they are far more difficult to remove.
- Never clean the oven surfaces by steam cleaning.
- The oven cavity should only be cleaned with warm soapy water, using either a sponge or soft cloth. No abrasive cleaners should be used.
- Any stains that may appear on the bottom of the oven will have originated from food splashes or spilt food, these splashes occur during the cooking process. These could possibly be a result of the food being cooked at an excessively high temperature or being placed in cookware that is too small.

! WARNING

Do not use stainless steel cleaning agents on the controls. Use neutral cleaning agents and avoid using harsh cleaning chemicals, strong household cleaners or products containing abrasive cleaners as this will affect the appearance of the appliance and may remove the printed symbols on the control panel.

- You should select a cooking temperature and function that is appropriate for the food that you are cooking. You should also ensure that the food is placed in an adequately sized dish and that you use the drip tray where appropriate.
- Outer parts of the oven should only be cleaned with warm soapy water, using either a sponge or soft cloth. No abrasive cleaners should be used.
- If you use any form of oven cleaner on your appliance, then you must check with the manufacturer of the cleaner that it is suitable for use on your appliance.
- Any damage that is caused to the appliance by a cleaning product will not be fixed free of charge, even if the appliance is within the guarantee period.

Cleaning the oven

No oven cleaner or any other special cleaning agent is required for cleaning the oven. It is recommended to wipe the oven with a damp cloth while it is still warm.

Cleaning side walls and oven door

1. Take down left and right side-shelves, method is pushing the bottom of shelves and pull to sides at the same time, push up side shelves and rotate up to level, and pull out the rack.
2. Cleaning left and right sides, order of install is opposite to the order of take down.

Removing the door from the oven

- To simplify cleaning the interior of the oven, the door can be removed.
- The process of removing the door is shown below:
 - ① Open the door to the maximum angle and pull the lock back at the hinge of the door (Figure 1). There are two locks on both sides of the oven door.
 - ② Close the oven door, at about 15 degree, then lift the door, and slowly pull out from the oven. (Figure 2)
 - ③ After cleaning, perform the above-mentioned operations in the opposite steps to restore the door to its original condition.

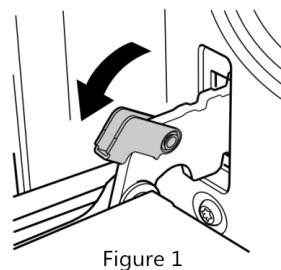

Figure 1

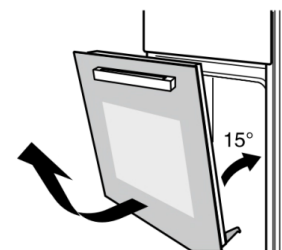

Figure 2

Note: After using a specific detergent, run the oven for 15-20 minutes with maximum heating settings to remove residues in the oven. In this process, touchable parts may be hotter than usual. Keep children away from the oven.

cont. cleaning & maintenance

Replacement of the oven light bulb.

CAUTION!

If the glass has some scratches, it may lead to crack. Don't use the glass container corrosive cleaning product or detergent to clean the glass.

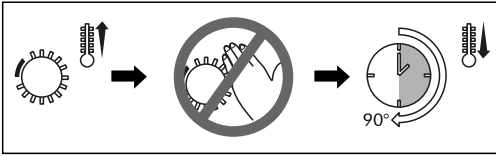

Not covered by the appliance guarantee.

Sensor Probe Replacement

The probe used in the oven is a mechanical physical probe. Do not replace it without authorization. In case of abnormal temperature sensing of the sensor probe, please contact the designated repair shop immediately for replacement.

WARNING

Disconnect the appliance from the electrical supply. Open the oven and remove the shelves.

Note:

The glass cover may be tight, may need a stronger grip to release it. Please release as shown.

The oven has a light with the following characteristics: 25W and 300°C.

1. During use of the appliance, it becomes hot. Care should be taken and avoid touching the heating elements inside the oven.
2. Ensure that the appliance is switch off before replacing the lamp to avoid the possibility of electric shock.
3. Remove the glass cover that protects the light bulb by turning it counter clockwise.
4. Unscrew the old light bulb and dispose it safely and ecologically.

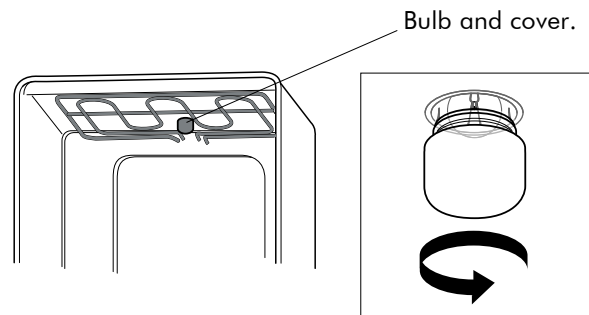

12. TROUBLESHOOTING

Observe all safety and warning information during operation. (see the General Safety Instructions" section)

Problem	Possible Cause	Possible Solution
The oven is not working	Interrupted electrical current	Check other electrical appliances if it is working.
	Breaker malfunction	Check your breaker if it is working fine.
	Forgot to activate the timer function	Reset the timer function
The lamp is not turning on	Defective lamp	Replace with a new lamp.
	No electrical current	Check if the oven have electrical power.
Oven suddenly stop working	Power interrupted	Check for other appliances if it is working.
	Normal close thermostat protection	Check if the cooling fan is working. If yes, replace with new thermostat.
Oven is not heating during operation	Can not adjust the temperature controller.	Check and setup the temperature.
	Timer may have been set up.	Check and adjust the timer.
	No power	Check the power box.
	Heating element is damaged.	Replace the heating element.
There is water coming out from the glass when operating.	Door seal is worn out.	Replace the door seal.
	Weak or damage hinges.	Replace the hinges.

If you have completed all of the above checks and is still experiencing difficulty, please contact your local Linarie Service Center (see the "Warranty and Spare Parts" sections).

WARNING

Any electrical repairs to this appliance must conform to your local, state and federal laws. Please contact the service center if in any doubt before undertaking any of the above. Always disconnect the unit from the power source when opening the unit.

13. ENVIRONMENTAL TIPS

Observe all safety and warning information during operation (see the "General Safety Instructions" section).

13.1 Disposal considerations

The transport and protective packaging has been selected from materials which are environmentally friendly for disposal, and can normally be recycled.

Recycling the packaging reduces the use of raw materials in the manufacturing process and also reduces the amount of waste in landfill sites. Ensure that any plastic wrappings, bags etc. are disposed of safely and kept out of the reach of babies and young children. Danger of suffocation.



13.2 Disposing of your old appliance

Electrical devices marked with this label may not be disposed of in domestic waste at the end of their service life.

Electrical and electronic appliances often contain valuable materials. They also contain specific materials, compounds and components, which were essential for their correct function and safety. These could be hazardous to human health and to the environment if disposed of with your domestic waste or if handled incorrectly. Please do not, therefore, dispose of your old appliance with your household waste.

Please dispose of those materials by contacting your local authorities and ask for the correct method of disposal. Please ensure that your old appliance poses no risk to children while being stored prior to disposal.

By disposing of this product in accordance with the regulations, you protect the environment and the health of those around you from negative consequences.

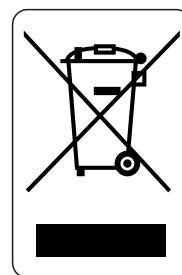

14. WARRANTY & AFTER SALES SERVICE

Observe all safety and warning information during operation (see the "General Safety Instructions" section).

In the event of a fault which you cannot remedy yourself, please contact Linärie.

14.1 Warranty

The manufacturer's warranty for this appliance is 2 years.

14.2 After sales service

The contact details for Linärie are given at the beginning and of these instructions.

When contacting Linärie, please quote the model and serial number of your appliance. These can be found on the data plate, after removing the grease filter.

Record model & serial number

Model:.....

Serial Number:.....

Register your product www.linarie.com.au

14.3 Replacement of spare parts

Incorrect components can lead to personal injury or damage to the appliance. Use only genuine original Linärie spare parts.



Modifications, additions or alterations to the appliance can lead to safety risks. If spare parts or accessories from other manufacturers are used, the warranty will be invalidated, and Linärie cannot accept liability.

Please check www.linarie.com.au for more information.

LIKE TO KNOW MORE?

For further information on all Linärie appliances,
or to obtain detailed dimension and installation
information, phone or email our Customer Care
team or visit our website:

Australia
hello@linarie.com.au
www.linarie.com.au

Follow Us
[@Linärie.Appliances](#)
  

Operating and installation instructions:

Original

√ Translation

Mart Online Services Pty Ltd.
ACN 657 824 050

Linärie Contact
hello@linarie.com.au
www.linarie.com.au

The distribution and duplication of this document, as well as the use and disclosure of its contents are prohibited unless expressly authorised.

These operating and installation instructions have been drawn up with the greatest of care. But it cannot be ruled out that subsequent technical modifications have not yet been incorporated or the relevant content has not yet been adapted. Please accept our apologies in this eventuality. An updated version can be requested from our team. Subject to printing errors and mistakes.

© Linärie

All rights reserved.