

Langon • LYBO70DMF

70L Electric Built-in Oven

Signature Features

Family Size

• 70L capacity with family size spacious interior

7 Cooking Modes

• Allowing you to conveniently bake, roast, grill, defrost, and more.

Even Heat Distribution

• Maximizes air circulation which effectively reduces cooking time by seamlessly distributing heat throughout the entire oven for the best cooking results

Ergonomically Designed

• Angled oven doors and soft shut hinges to secure heat inside while preventing slamming by delicately closing its doors

Full Visibility

• Sophisticated extra-wide glass pane to help you monitor your dishes while keeping its exterior temperature cool to the touch



70L Family Size	 7 Cooking Modes	 Roast & Bake	 Grill	 Convection	 Defrosting	 Rear Fan	Up To 250°C Temperature	 Even Heat Distribution	 LED Light	 Removable Shelf
 Ergonomic Design	 Tempered Door	 Full Visibility	 Compact Design	 Easy Installation	 Intuitive Control	 Child Lock	 Warranty	 Easy Cleaning	 Space Saving	 Quiet Operation



Langon • LYBO70DMF

70L Electric Built-in Oven

Technical Features

Materials / Color:	Black glass & stainless steel
Installation:	Built-in
Voltage / Frequency:	220-240V, 50Hz
Max Current:	230V/16A
Power Source:	Electrical
Max/Total Power:	2200W
Power Cable:	Wire; Must be earthed
Energy Efficiency Rate:	A

Oven Features

Capacity:	70 Liters
Bar Handle:	Aluminum
Temperature Range:	50-250°C
Cooking Modes:	7 Modes Defrosting, Bottom Heat, Lower Heat + Upper Heat (Convection), Double Grilling, Radiant Grilling + Fan, Conventional + Fan, Convection
Timer:	Up to 10h
Integrated Cleaning System:	No
Temperature Control:	Electronic and Mechanical Control
Cooling Rear Fan:	Yes
Forced cooling & Smoke Ventilation:	Yes
Light Type:	Halogen
Indicators / Display:	No
Number of shelf positions:	5
Interior Design:	Enamel

Parameters

Top Heating Element:	1000W
Grill Heating Element:	1200W
Bottom Heating Element:	1000W
Convection Heating Element:	1800W
Oven Lamp:	25W
Cooling Fan:	12W
Convection Motor:	35W

7 Cooking Modes

Electric Built-in Oven | Langon • LYBO70DMF



Control Display

linärie

Electric Built-in Oven | Langon • LYBO70DMF

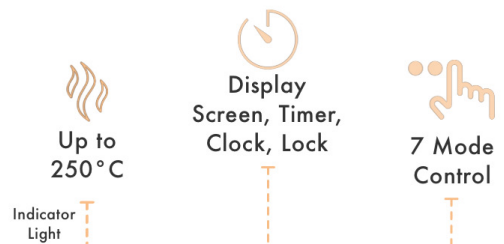

Langon • LYBO70DMF

70L Electric Built-in Oven

Safety Features

Child Lock:	Yes
Door Lock:	Yes
Inner Door Plate	Low-e
Double layered door	Yes

Dimensions & Weight

Cavity:	497(W) x 400(D) x 350 (H) mm
Packed Dimensions:	675 (W) x 645 (D) x 665 (H) mm
Packed Weight:	31kg
Unpacked Dimensions:	595 (W) x 565 (D) x 595 (H) mm
Unpacked Weight:	28kg

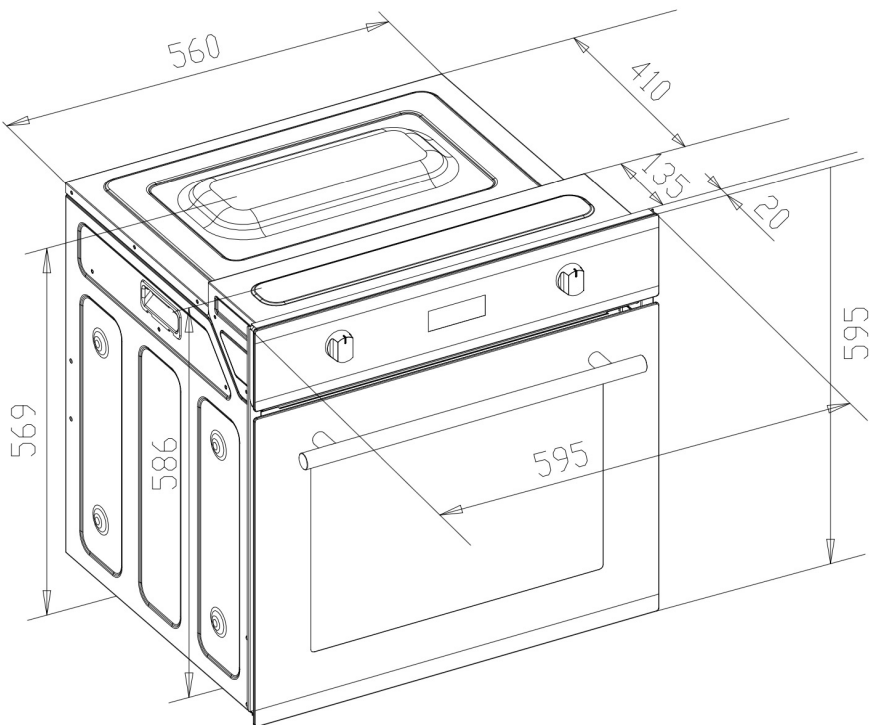

EAN Number

0731093140624

Accessories

Oven Drip Tray (enameled)	1
Oven Wire Rack	1

Warranty

- Two (2) year parts and labor
- *Extend your warranty by registering your Product at linarie.com.au

