

linarie

20  
LITRE

# CALVI BUILT-IN MICROWAVE OVEN

LJMO20XBI

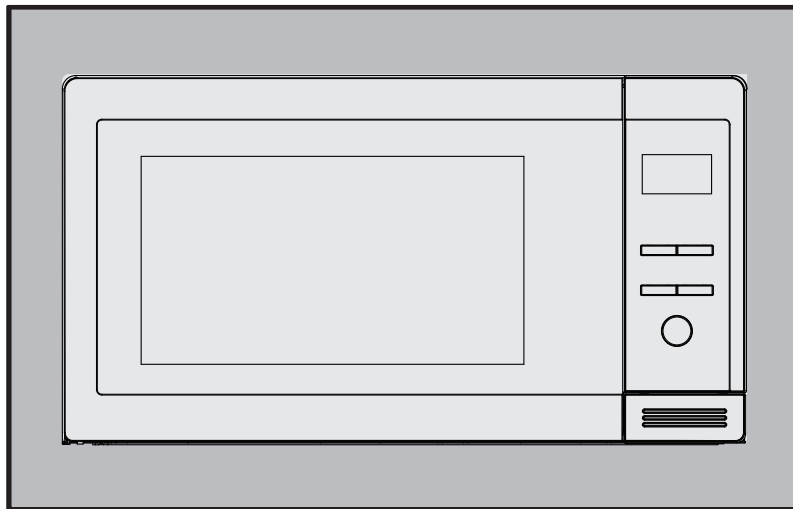

**EN** Operation, Installation  
& Instruction Manual

[www.linarie.com.au](http://www.linarie.com.au)

Register  
your  
product  
online

# CONGRATULATIONS

Congratulations and thank you for choosing Linärie to introduce a new comfort of cooking in your home. We are sure you will find your new appliance a pleasure to use and a great asset to your kitchen.

This appliance complies with all relevant safety requirements in Australia. Inappropriate use can, however, lead to personal injury and damage to property.

In order to operate the unit correctly and safely, please read this instruction manual carefully before installation and usage. This user manual which provides you with all required instructions related to safety, installation, use and maintenance of the appliance.

For future reference, please store this booklet in a safe place and ensure that all users are familiar with the contents. Pass them on to any future owner of the appliance.

Record Model & Serial Number

Model:.....

Serial Number .....

Register your product [www.linärie.com.au](http://www.linärie.com.au)

## IMPORTANT

Adherence to the directions for use in this manual is extremely important for health and safety. Failure to strictly adhere to the requirements in this manual may result in personal injury, property damage and affect your ability to make a claim under Linärie's manufacturer's warranty provided with your product. Products must be used, installed and operated in accordance with this manual. You may not be able to claim on Linärie's manufacturer's warranty in the event that your product fault is due to failure to adhere this manual.

### Correct Conditions of Use

- The appliance is intended for use in the home and similar environments only. It is not intended for commercial use.
- The appliance is not suitable for outdoor use, non-stationary installation or heating rooms.
- The microwave oven is intended for defrosting, cooking and steaming of food only.

 Linärie does not assume any liability for damage arising from non-adherence to these documents and from improper assembly. The electricity connection must be made by a qualified specialist. Installation must comply with the valid standards, regulations and laws. All safety and warning information and the operating and installation instructions must be complied with.

## TABLE OF CONTENTS

<b>1. General Information</b> .....	03	<b>5. Operation</b> .....	07
1.1 Appliance information		5.1 Control panel	
<b>2. General Safety Instructions</b> .....	03	5.2 Before using the oven for the first time	
2.1 General safety information		5.3 Operation instruction .....	07
2.2 Safety instruction - Installation		<b>6. Troubleshooting</b> .....	08
2.3 Safety instruction - Use and operation .....	04	<b>7. Care of your microwave oven</b> .....	08
2.4 Correction use and Operation .....	04	<b>8. Schematic diagram</b> .....	09
<b>3. Technical data sheet</b> .....	05	<b>9. Environmental tips</b> .....	10
3.1 Specification		9.1 Disposal consideration	
3.2 Features		9.2 Disposing of your old appliance	
<b>4. Installation</b> .....	05	<b>10. Warranty and after sales</b> .....	10
4.1 Components		10.1 Warranty	
4.2 Trim kit specification		10.2 After sales	
4.3 Cabinetry .....	06	10.3 Replacement of spareparts	
4.4 Frame installation procedure			

Additional information on products, accessories, warranty, replacement parts and services can be found at [www.linärie.com.au](http://www.linärie.com.au)

# 1. GENERAL INFORMATION

## 1.1 Appliance Information

- A damaged appliance can be dangerous. If you find the appliance is damaged or marked, you must report it within 7 days if you wish to claim for damage/marks under the manufacturer's warranty. This does not affect your statutory rights. Do not use a damaged appliance.
- The manufacturer's warranty will be invalidated if the appliance is not repaired by a Linärie approved service technician.
- Faulty components must only be replaced by genuine Linärie spare parts. The manufacturer can only guarantee the safety of the appliance when Linärie replacement parts are used.
- If the power cord is damaged, it must only be replaced by a Linärie authorized service technician or suitably qualified electrician in order to avoid a hazard.
- Linärie cannot be held liable for noncompliance with these instructions, resulting from incorrect or improper use or operation.

# 2. GENERAL SAFETY INSTRUCTIONS

 The appliance complies with the stipulated safety requirements in Australia. The user is responsible for appliance cleaning and maintenance as well as its safe use. Improper use can lead to personal injury and damage to property.

## Unauthorized Modifications

Unauthorised modifications can cause the appliance to pose risks. Do not conduct any modifications to the appliance.

## 2.1 General Safety Instructions

### Children and People with Special Needs

#### WARNING

This appliance is not intended for use by persons (including children) with reduced physical, sensory or mental capabilities, or lack of experience and knowledge, unless they have been given supervision or instruction concerning use of the appliance by a person responsible for their safety.

- The appliance is NOT suitable for use by children without supervision.
- Young children should be supervised near the appliance to ensure they do not play with this appliance.
- Children may be able to wrap themselves in packing material or pull it over their heads with the risk of suffocation. Keep children away from any packing material.

### Cleaning & Maintenance

The device must be cleaned regularly. Dirt can lead to damage or the buildup of odors.

- Always clean the appliance exactly as indicated in the operating instructions.
- Always ensure the appliance is switched off before cleaning or replacing parts.
- Clean the appliance immediately after any food spillage to keep the appliance working efficiently.
- There is a risk of fire if cleaning is not carried out as described in these operating instructions.
- Make sure no water penetrates inside the device when cleaning. Do not use a steam cleaning appliance to clean this appliance. The steam could reach electrical components and cause a short circuit.
- In areas which may be subject to infestation by cockroaches or other vermin, pay particular attention to keeping the machine and its surroundings in a clean condition at all times. Any damage which may be caused by cockroaches or other vermin will not be covered by the machine warranty.
- Do not use this microwave oven to heat chemicals or other non-food products. Do not clean this oven with any product that is labelled as containing corrosive chemicals. The heating of corrosive chemicals in this oven may cause microwave radiation leaks.
- If the base of the oven is hot, allow to cool before cleaning or placing in water.

## 2.2 Safety Instructions - Installation

#### WARNING

The appliance must only be installed and assembled by trained specialists who are familiar with and comply with the standard national regulations and supplementary regulations of ventilation systems.

- In order to avoid any potential hazard, the installation instructions must be followed.
- Observe all regional regulations for the installation of ventilation systems.
- During installation, maintenance and repair work, the appliance must be disconnected from the mains electricity supply. It is only completely isolated from the electricity supply when:
  - the mains circuit breaker is switched off, or
  - it is switched off at the wall socket and the plug is withdrawn from the socket.
- Do not pull the mains connection cable but the mains plug to disconnect your appliance from the main electricity supply.
- Do not connect the appliance to the mains electricity supply by a multi-socket unit or an extension lead.
- Extension leads are a fire hazard and do not guarantee the required safety of the appliance.
- Tampering with electrical connections or components and mechanical parts is highly dangerous to the user and can cause operational faults. Only open the housing as described in the instructions given in "Installation" and in the "Cleaning & Maintenance" sections of this booklet. Under no circumstances should any other parts of the housing be opened.
- THIS APPLIANCE MUST BE PROPERLY EARTHED. It is most important that this basic safety requirement is present and tested regularly and, where there is any doubt, the household wiring system should be inspected by a qualified electrician.
- Linärie cannot be held liable for noncompliance with these instructions, resulting from incorrect or improper use or operation.

## 2.3 Safety Instructions - Use and Operation

- Do not tamper with or deactivate the interlocking devices on the door.
- Do not poke an object, particularly a metal object, through a grille or between the door and the oven while the oven is operating.
- Do not place saucepans, unopened cans or other heavy metal objects in the oven.
- Do not let other metallic articles, e.g., fast food foil containers, touch the side of the oven.
- Clean the oven cavity, the door and the seals with water and a mild detergent at regular intervals. Never use any form of abrasive cleaner that may scratch or scour surfaces around the door.
- Always use the oven with trays or cookware recommended by the manufacturer.
- Do not operate the oven without a load (i.e., an absorbing material such as food or water) in the oven cavity unless specifically allowed in the manufacturer's literature.
- For horizontally hinged doors, never rest heavy objects such as food containers on the door while it is open.
- Do not place sealed containers in microwave ovens. Baby bottles fitted with a screw cap or a teat are considered to be sealed containers.
- Young children should be supervised to ensure that they do not play with the appliance. The surfaces are liable to get hot during use.

---

## 2.4 Correction use and Operation

- For safety reasons, this appliance may only be used after it has been built in.
- Reliable and safe operation of this appliance can only be assured if it has been connected to the mains electricity supply.
- Before using the appliance, ensure that all packaging materials are removed from the appliance and make sure that the connection data on the data plate [voltage (V) and frequency (Hz)] indicated on the appliance corresponds to the voltage and frequency of the power supply in your household. Consult a qualified electrician if in doubt.
- In order to maintain high quality, do not operate the oven when empty. The microwave energy will reflect continuously throughout the oven if no food or water is present to absorb energy. This can lead to damage to the microwave oven including arcing within the oven cavity.
- If smoke is observed, press the STOP/RESET Pad and leave door closed in order to stifle any flames. Disconnect the power cord, and/or shut off power at the fuse or circuit breaker panel.
- Do not dry clothes, newspapers or other materials in oven. They may catch on fire.
- Do not use recycled paper products, unless the paper product is labelled as safe for microwave oven use. Recycled paper products may contain impurities which may cause sparks and/or fires when used.
- Do not use newspapers or paper bags for cooking.
- Do not hit or strike the Control Panel. Damage to controls may occur.
- POT HOLDERS may be needed as heat from food is transferred to the cooking container and from the container to the oven. The oven can be very hot after removing the cooking container from the oven.
- Do not store or spray flammable materials next to, on top of, or in the oven. It could be a fire hazard.
- Do not cook food directly on the flat table unless indicated in recipes. Liquids, including eggs or other food must be placed in a suitable cooking utensil.
- During cooking, some steam will condense inside and/or on the oven door. This is normal and safe. Steam will disappear after the oven cools down.
- Do not leave the microwave unattended while reheating or cooking food in disposable containers made of plastic, paper or other combustible materials, as these types of containers can ignite if overheated.
- The microwave oven is intended for heating food and beverages. Drying of food or clothing and heating of warming pads, slippers, sponges, damp cloth and similar may lead to risk of injury, ignition or fire.
- Always test the temperature of cooked food yourself especially if you are heating or cooking food/liquid for babies. It is advisable never to consume food/liquid straight from the oven but allow it to stand for a few minutes and stir food/ liquid to distribute heat evenly.
- Food containing a mixture of fat and water, e.g. stock, should stand for 30-60 seconds in the oven after it has been turned off. This is to allow the mixture to settle and to prevent bubbling when a spoon is placed in the food/liquid or a stock cube is added.
- When preparing/cooking food/liquid and remember that there are certain foods, e.g. Christmas puddings, jam and mincemeat, which heat up very quickly. When heating or cooking foods with a high fat or sugar content do not use plastic containers.

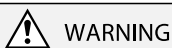

To reduce the risk of fire in the oven cavity:

- Do not overcook food. Carefully attend microwave oven if paper, plastic, or other combustible materials are placed inside the oven to facilitate cooking.
- Remove wire twist-ties from bags before placing bag in oven.
- If materials inside the oven should ignite, keep oven door closed, turn the oven off at the wall switch, or shut off power at the fuse or circuit breaker panel.

### 3. TECHNICAL DATA SHEET

This appliance is only suitable for cooking food. Do not use it for other purposes, i.e. for storage purposes. Otherwise, it might lead to damage to the appliance or personal injury.

#### 3.1 Specification

Parameter	Value
Power consumption	220-240V~50Hz,1080W
Output	700W
Operating Frequency	2,450MHz
Outside Dimensions	592mm(W) X 313mm(D) X 376mm(H)
Oven Cavity Dimensions	315mm(W) X 296mm(D) X 211mm(H)
Oven Capacity	20 litres
Uncrated Weight	Approx. 13.3kg

FLATWAVE TECHNOLOGY		FLATWAVE TECHNOLOGY
<ul style="list-style-type: none"> <li>• Allow the flat table to cool before cleaning.</li> <li>• Do not cook directly on the flat table. Always put the food in the container special for the microwave oven.</li> </ul>		

#### 3.2 Features

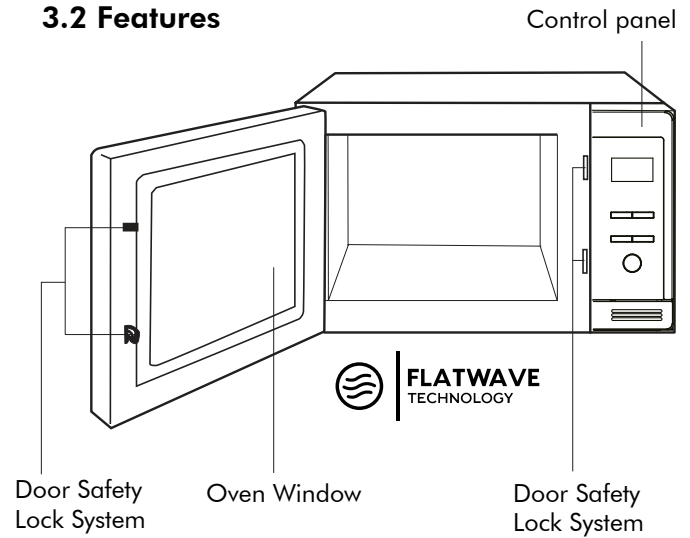

The oven light will turn on during cooking and also when the door is opened.

### 4. INSTALLATION

 <b>WARNING</b>
<p>To reduce the risk of fire in the oven cavity:</p> <ul style="list-style-type: none"> <li>• Make sure all the packing materials are removed from inside the door.</li> <li>• Inspect the oven after unpacking for any visual damage. If any of the following are visible, DO NOT use the oven: <ul style="list-style-type: none"> <li>- Misaligned door, damaged door, dents or holes in door window and screen dents in cavity.</li> </ul> </li> </ul>

#### Circuits



- Our oven should be operated on a separate 10A circuit from other appliances. Failure to do this may cause the power board fuse to blow, and/or food to cook slower. Do not insert higher value fuse in the power board.

#### Placement of Oven

[only applicable for built-in models]

- Microwave ovens should not be built into a unit directly above a top front venting conventional cooker. This may be a safety hazard and could result in damage to your oven. This will invalidate your two year guarantee.
- A microwave which is built in must be more than 850mm above floor level. It is recommended that the microwave oven is placed below a conventional oven to avoid heat damage to the fascia of the microwave.
- The oven must be placed on a flat, stable surface. For correct operation, the oven must have sufficient air flow. Allow 15 cm of space on the top of the oven, 10cm at the back, and 5 cm on both sides. If one side of the oven is placed flush to wall, the other side or top must not be blocked. Do not remove the feet.

#### 4.1 Components

- 1 pc screw cover 
- 1 pc screw 4x45mm 
- 2 pcs screw 3x30mm 

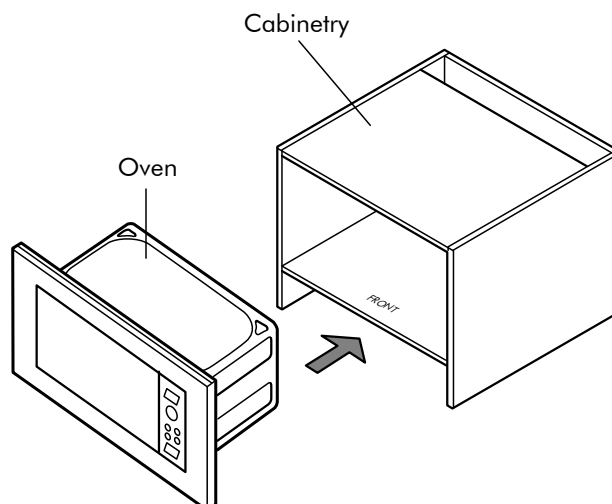

#### 4.2 Trim kit specification

**Cavity dimensions**  
Width 566-580mm  
Height 365-380mm  
Depth 550mm

**Frame dimensions**  
Width 592mm  
Height 390mm  
Depth 20mm

## cont. installation

### 4.3 Cabinetry

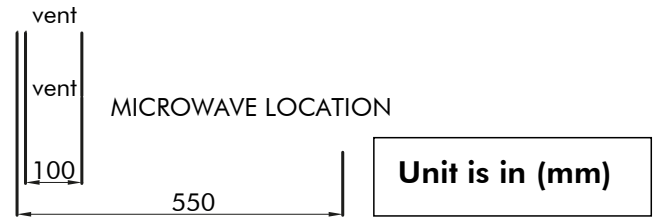
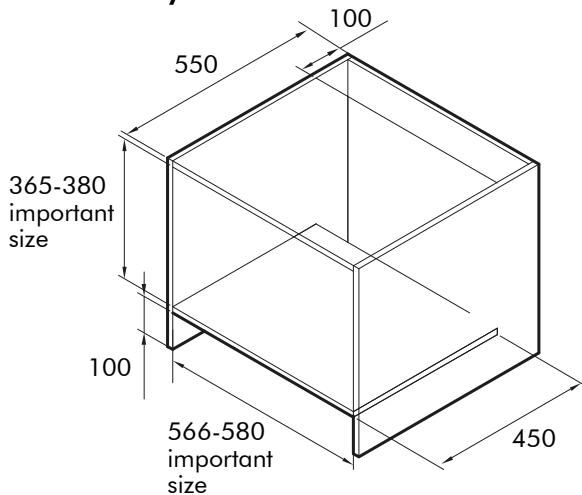

Cabinet measurement Requirements (illustrated above):

- 1) Cabinet's length is 566-580mm. Minimum distance.
- 2) Cabinet's height is 365-380mm. Minimum distance.
- 3) Cabinet's depth should be no less than 550mm.
- 4) Outside dimension of cabinet should be no less than 596mm, as the frame length is 592mm.
- 5) Cabinet's board less than 15mm or 20mm thick.

### 4.4 Frame installation procedure

- 1) Put the microwave oven into the cabinet and keep the microwave oven in a horizontal direction while maintaining the edge distance.
- 2) Fix the oven to the cabinet using 2 3x30mm screw. Refer to image below.

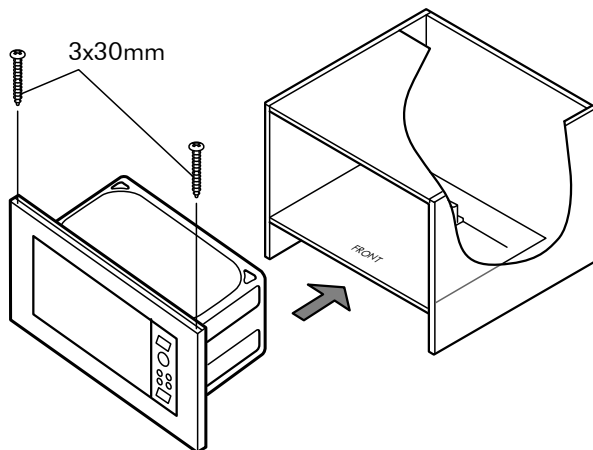

- 3) Open the microwave oven, fix with 4x45 screw and add screw cover.

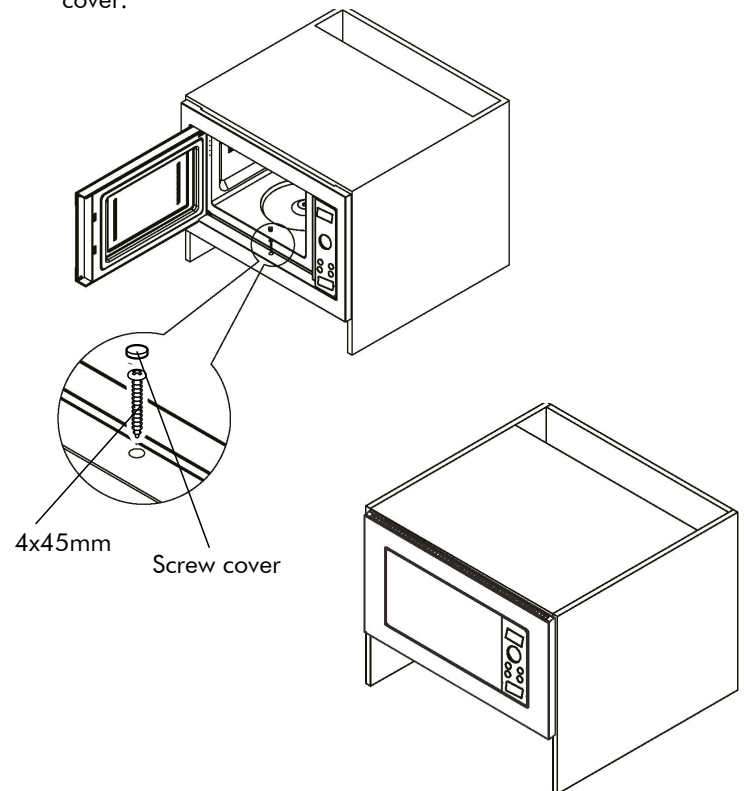

### ! IMPORTANT

The wires in this mains lead are coloured in accordance with the following code:

Green-and-yellow : Earth

Blue : Neutral

Brown : Live

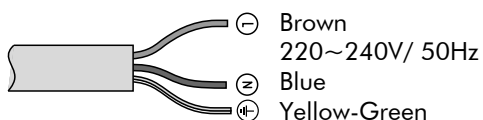

- As the colours of the wires in the mains leads of the appliance may not correspond with the coloured markings identifying the terminals in your plug, proceed as follows:
- The wire which is coloured green-and-yellow must be connected to the terminal in the plug which is marked with the letter E or by the earth symbol  coloured green of green-and-yellow.
- The wire which is coloured blue must be connected to the terminal which is marked with the letter N or coloured black.
- The wire which is coloured brown must be connected to the terminal which is marked with the letter L or coloured red.

## 5. OPERATION

### 5.1 Control panel

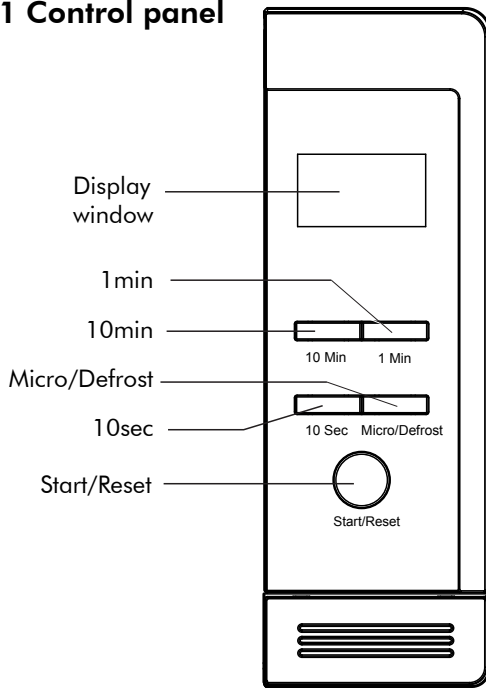

### 5.2 Before using the oven for the first time

 **WARNING** (for applicable models only)

You can use the oven without setting the clock.  
Oven will not operate while colon is still blinking.

Clock is 24h display and will keep the time of day as long as oven is plugged in and electricity is supplied.

Plug into a properly earthed electrical outlet. "88:88" appears in the Display Window. (This will immediately cease when any pad is pressed.)

- 1) Press "CLOCK/TIMER"  
The control panel display will flash. Adjust the hour by pressing the "Time / Weight" buttons.
- 2) Press "CLOCK/TIMER" again  
Adjust the minutes by pressing the "Time / Weight" buttons.
- 3) Press "CLOCK/TIMER" again so that the clock can be set

Follow the procedure above anytime you want to adjust the clock.

#### Beep sound

When pad is pressed correctly, a beep sound will be heard. If a pad is pressed and no beep is heard, the unit does not or cannot accept instruction. The oven will beep twice between programmed stages. At the end of any complete program, the oven will beep five times.

### 5.3 Operation instruction

#### 1. SIMPLE COOKING

- 1) You only need to press "START/RESET" to start cooking.  
Next press means increasing one minute cooking time, the maximum time is 30min. When cooking is done, you will hear 5 beeps.
- 2) Press and hold the "Start/Reset" for 2 seconds to stop.

#### 2. MICROWAVE COOKING

##### Fast cooking method

(For example:  
Select 100% power to cook foods for 5 minutes.)

- 1) Set the time "5:00"
- 2) Press "START/RESET" button

##### Control by hand

(For example:  
Select 70% power to cook foods for 10 minutes)

- 1) Press "Micro/Defrost" button to select 70% power.
- 2) Press time button to set cooking time "10:00"
- 3) Press "START/RESET" button.

You can press "Micro/Defrost" button to select power.

Step	Display	Micro power
1	P10	100%
2	P7	70%
3	P5	50%
4	P3	30%
5	P1	10%

#### 3. AUTO DEFROST FUNCTION

You need to press "1Min" (1.0kg-2.0kg) and "10Sec" (0.1kg-0.9kg) according to the weight of the food. The oven can select defrosting program and auto start defrosting.

For example: defrost 0.4kg frozen foods

- 1) Press "Micro/Defrost" to choose defrost function, display "dEF".  
Set weight "0.4kg" by pressing "10Sec" buttons.
- 2) Press "START/RESET" button.  
Remark: the maximum weight is 2kgs

#### 4. START AND RESET

Open door status

- 1) Press "START/RESET" button to cancel setting or cooking program.

Close door status

- 1) Press "START/RESET" button to start cooking after setting cooking program.
- 2) Press "START/RESET" button to continue cooking when the cooking is in pause status.
- 3) Press "START/RESET" button to stop working when the microwave oven is operating.

#### 5. CHILDREN SAFETY LOCK

To activate the Child Lock, press "1Min" and "10Sec" buttons at the same time for 2 seconds.

After that press all buttons are inactive/ locked. Pressing "1Min" and "10Sec" button at the same time for 2 seconds again will unlock this function.

Press for 2 seconds to activate/deactivate.

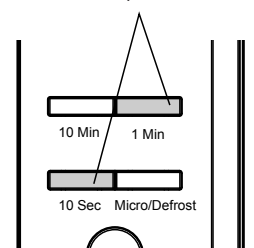

## 6. TROUBLESHOOTING

PROBLEM	POSSIBLE CAUSE	SOLUTION
Oven will not turn on.	The oven is not plugged in securely.	Remove plug from outlet, wait 10 seconds and re-insert.
	Circuit breaker or fuse is tripped or blown.	Reset circuit breaker or replace fuse.
	There is a problem with the outlet.	Plug another appliance into the outlet to check if the outlet is working.
The microwave power does not function.	a. Check to see whether the timer is set. b. Check to make sure that the door is securely closed to engage the safety interlocks. Otherwise, the microwave energy will not flow into the oven.	
	The door is not closed completely.	Close the oven door securely.
	Start button was not pressed after programming.	Press Start button.
	Another program has already been entered into the oven.	Press Stop/Reset button to cancel the previous program and program again.
	The program has not been entered correctly.	Program again according to the Operating Instructions.
The oven will not start cooking.	Stop/Reset button has been pressed accidentally.	Program oven again.
	The oven causes interference with my TV, radio or similar equipment.	a. Clean the door and sealing surface of the oven. b. Place the radio, TV, etc. as far away from your microwave oven as possible. c. Use a properly installed antenna for your radio, TV, etc. to get a strong signal reception.
Steam accumulates on the oven door and warm air comes from the oven vents.	During cooking, steam and warm air are given off from the food.	During cooking, steam and warm air are given off from the food. Most of the steam and warm air are removed from the oven by the air which circulates in the oven cavity. However, some steam will condense on cooler surfaces such as the oven door. This is normal.

## 8. CARE OF YOUR MICROWAVE OVEN

### GENERAL INFORMATION

- Allow the appliance to cool down completely before cleaning and maintenance.
- The surface and controls are susceptible to scratches and abrasion. Please observe the following cleaning instructions.

### WARNING

Observe all safety and warning information during operation (see the "General Safety Instructions" section). Before maintenance or cleaning, the appliance should always be disconnected from the power supply. Make sure that the appliance is switch off and the plug has been removed. Exterior surfaces are prone to scratches and dents. Therefore, please follow the cleaning instructions to achieve the best possible result without damage.

- Keep the inside of the oven clean. When food splatters or spilled liquids adhere to oven walls, wipe with a damp cloth.
- The use of harsh detergent or abrasives is not recommended. The outside oven surface should be cleaned with a damp cloth. To prevent damage to the operating parts inside the oven, water should not be allowed to seep into the ventilation openings.
- Do not allow the Control Panel to become wet. Clean with a soft, damp cloth. Do not use detergents, abrasives or spray-on cleaners on the control Panel. After cleaning touch Stop/Reset key to clear display window.
- If steam accumulates inside or around the outside of the oven door, wipe with a soft cloth. This may occur when the microwave oven is operated under high humidity conditions and in no way indicates malfunction of the unit.

- Do not use harsh abrasive cleaners or sharp metal scrapers to clean the oven door glass since they can scratch the surface, which may result in shattering of the glass.
- It is occasionally necessary to remove the glass tray for cleaning. Wash the tray in warm sudsy water or in a dishwasher.
- Always clean the flat table after cooling down with a mild detergent and wipe to dry.
- The roller ring and oven cavity floor should be cleaned regularly to avoid excessive noise. Simply wipe the bottom surface of the oven with mild detergent, water or window cleaner and dry. The roller ring may be washed in mild sudsy water or dish washer. Cooking vapour collected during repeated use does not affect the bottom surface or roller ring wheels. When removing the roller ring from cavity floor for cleaning, be sure to replace it in the proper position.
- Remove odors from your oven by combining a cup of water with the juice and skin of one lemon in a deep microwaveable bowl. Microwave for 5 minutes, wipe thoroughly and dry with a soft cloth.
- When it becomes necessary to replace the oven light, please consult a specialist to have it replaced.

### WARNING

Failure to maintain the oven in a clean condition could lead to deterioration of the surface that could adversely affect the life of the appliance and possibly result in a hazardous situation.



## 8. SCHEMATIC DIAGRAM

(DOOR OPENED, COOK OFF CONDITION)

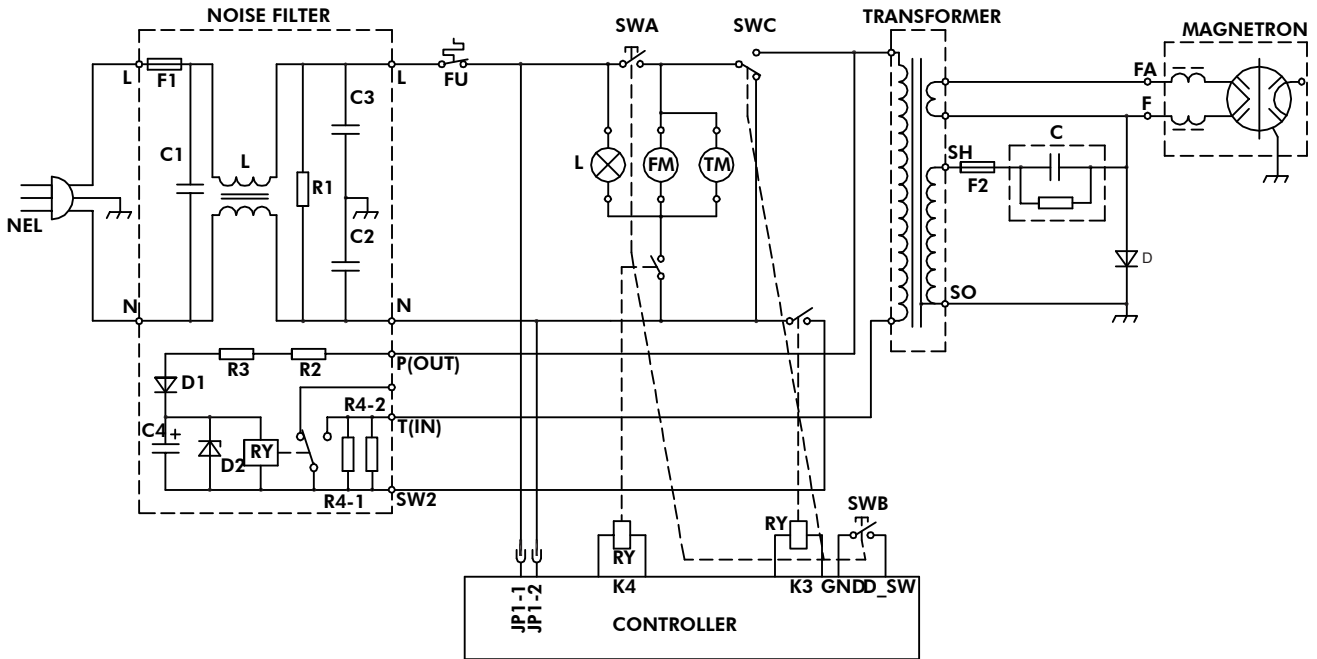

- 1) SWA: PRIMARY INTERLOCK SWITCH
- 2) SWB: SECONDARY INTERLOCK SWITCH
- 3) SWC: THE MONITOR INTERLOCK SWITCH

- 4) L: LAMP
- 5) FM: FAN MOTOR
- 6) TM: TURNTABLE MOTOR
- 7) H: HEATER

\* Circuit is subject to change without prior notice.

## 9. ENVIRONMENTAL TIPS

Observe all safety and warning information during operation (see the "General Safety Instructions" section).

### 9.1 Disposal considerations

The transport and protective packaging has been selected from materials which are environmentally friendly for disposal, and can normally be recycled.

Recycling the packaging reduces the use of raw materials in the manufacturing process and also reduces the amount of waste in landfill sites. Ensure that any plastic wrappings, bags etc. are disposed of safely and kept out of the reach of babies and young children. Danger of suffocation.



### 9.2 Disposing of your old appliance

Electrical devices marked with this label may not be disposed of in domestic waste at the end of their service life.

Electrical and electronic appliances often contain valuable materials. They also contain specific materials, compounds and components, which were essential for their correct function and safety. These could be hazardous to human health and to the environment if disposed of with your domestic waste or if handled incorrectly. Please do not, therefore, dispose of your old appliance with your household waste.

Please dispose of those materials by contacting your local authorities and ask for the correct method of disposal. Please ensure that your old appliance poses no risk to children while being stored prior to disposal.

By disposing of this product in accordance with the regulations, you protect the environment and the health of those around you from negative consequences.

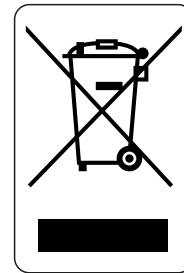

## 10. WARRANTY & AFTER SALES SERVICE

Observe all safety and warning information during operation (see the "General Safety Instructions" section).

In the event of a fault which you cannot remedy yourself, please contact Linärie.

### 10.1 Warranty

The manufacturer's warranty for this appliance is 2 years.

### 10.2 After sales service

The contact details for Linärie are given at the beginning and of these instructions.

When contacting Linärie, please quote the model and serial number of your appliance. These can be found on the data plate, after removing the grease filter.

### Record model & serial number

Model:.....

Serial Number:.....

Register your product [www.linarie.com.au](http://www.linarie.com.au)

### 10.3 Replacement of spare parts

Incorrect components can lead to personal injury or damage to the appliance. Use only genuine original Linärie spare parts.



Modifications, additions or alterations to the appliance can lead to safety risks. If spare parts or accessories from other manufacturers are used, the warranty will be invalidated, and Linärie cannot accept liability.

Please check [www.linarie.com.au](http://www.linarie.com.au) for more information.

## LIKE TO KNOW MORE?

For further information on all Linärie appliances,  
or to obtain detailed dimension and installation  
information, phone or email our Customer Care  
team or visit our website:

Australia  
[hello@linarie.com.au](mailto:hello@linarie.com.au)  
[www.linarie.com.au](http://www.linarie.com.au)

Follow Us  
[@Linarie.Appliances](#)  
  

©Linärie

Operating and installation instructions:

Original

√ Translation

**Mart Online Services Pty Ltd.**  
**ACN 657 824 050**

**Linärie Contact**  
**hello@linarie.com.au**  
**www.linarie.com.au**

The distribution and duplication of this document, as well as the use and disclosure of its contents are prohibited unless expressly authorised.

These operating and installation instructions have been drawn up with the greatest of care. But it cannot be ruled out that subsequent technical modifications have not yet been incorporated or the relevant content has not yet been adapted. Please accept our apologies in this eventuality. An updated version can be requested from our team. Subject to printing errors and mistakes.

© Linärie

All rights reserved.