

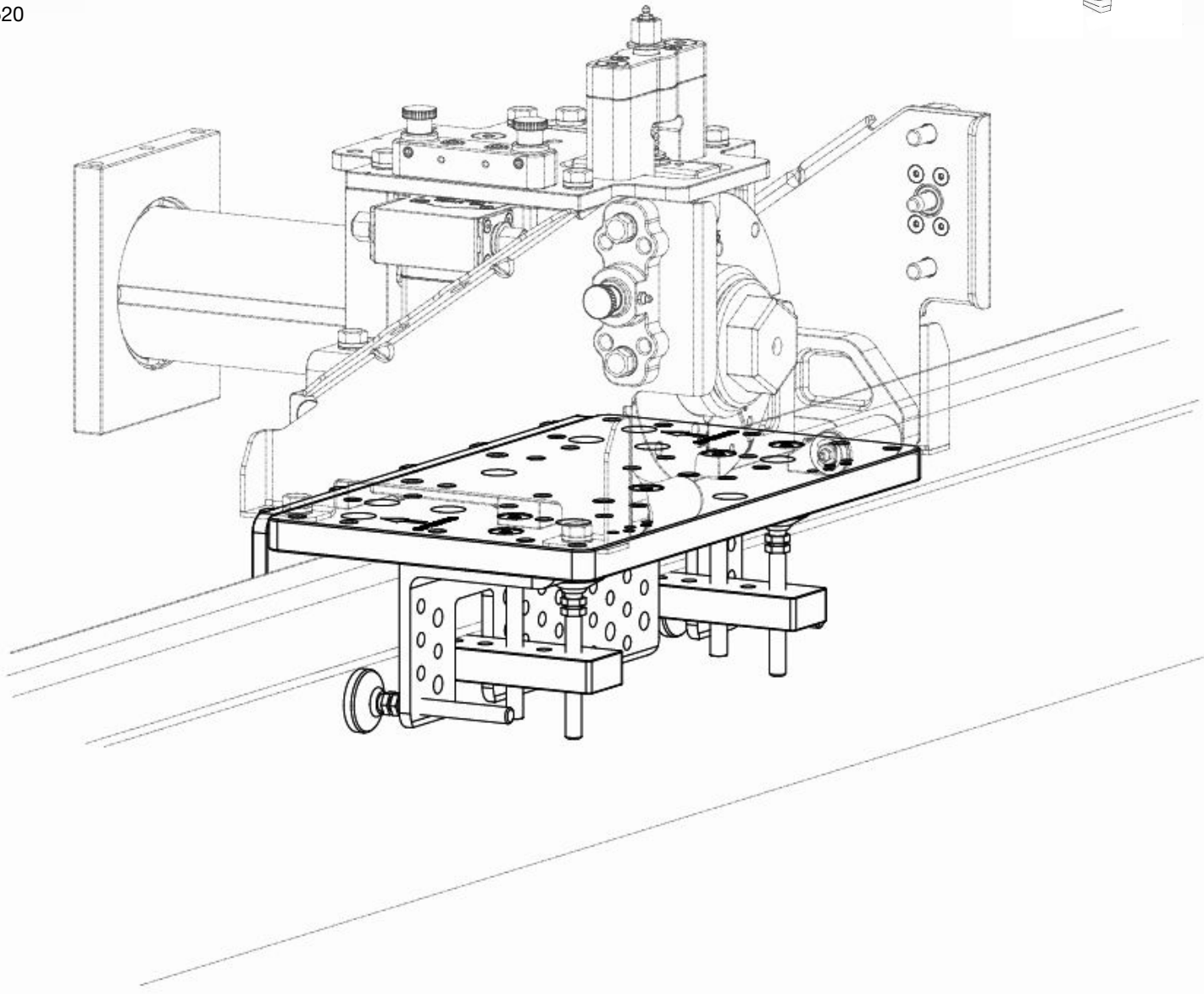

Patent #8094520

STANDARD VOOP

USER MANUAL

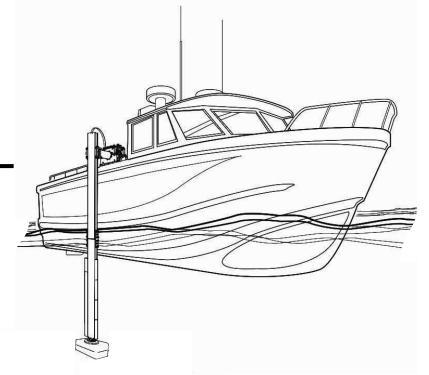

SCAN FOR VIDEO



SCAN FOR ALL
USM VIDEOS



GENERAL OVERVIEW

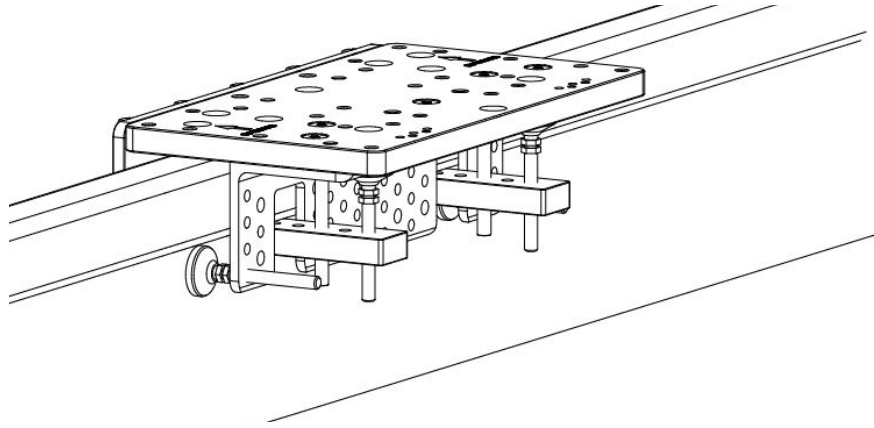

NARROW

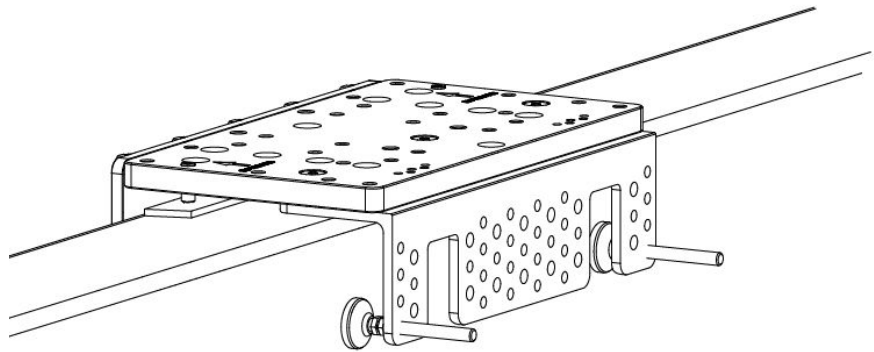
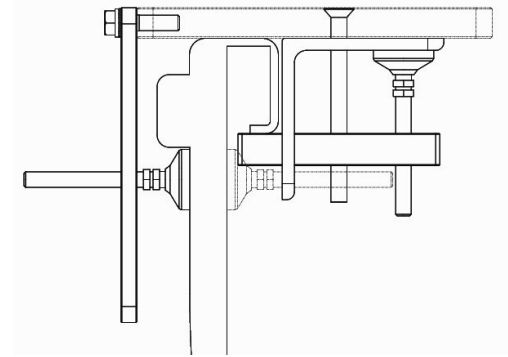

WIDE

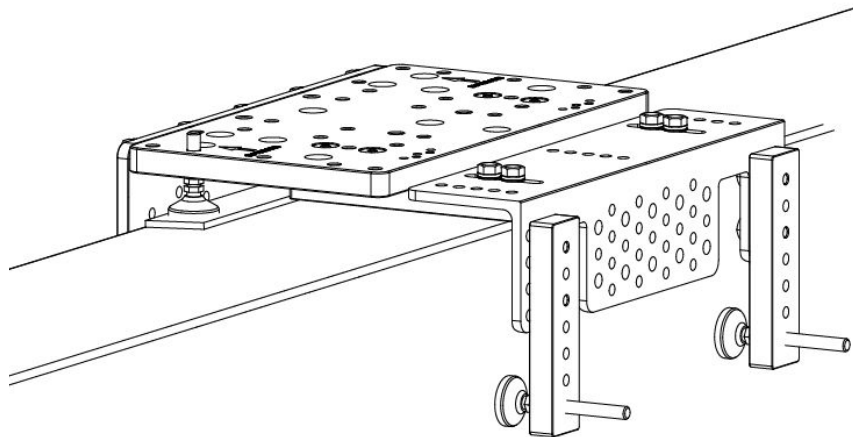
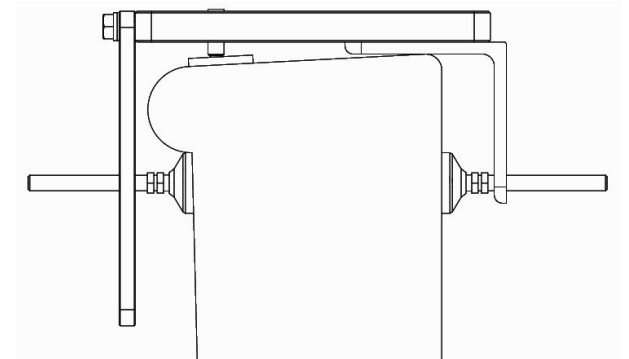

EXTENDED

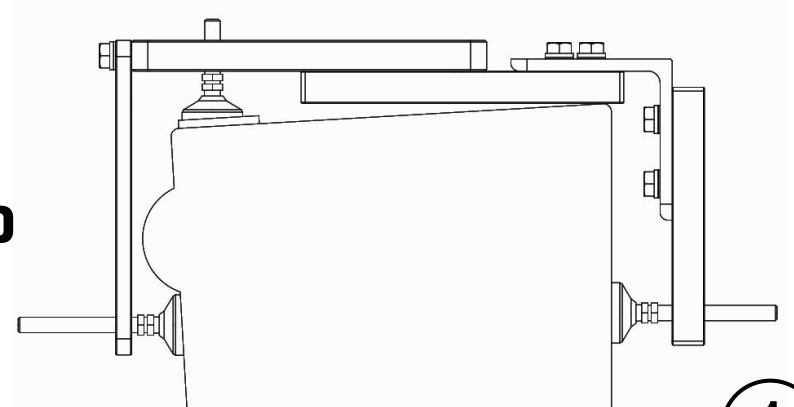



COMPONENTS OVERVIEW

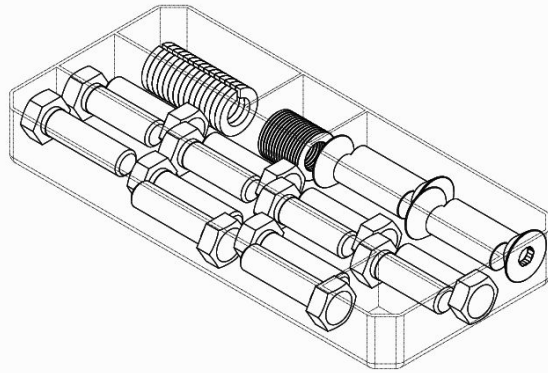

HARDWARE KIT A

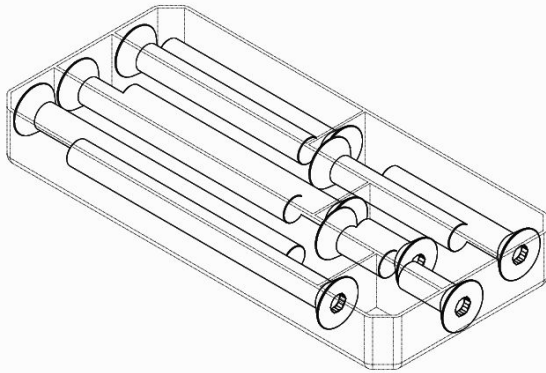

HARDWARE KIT B

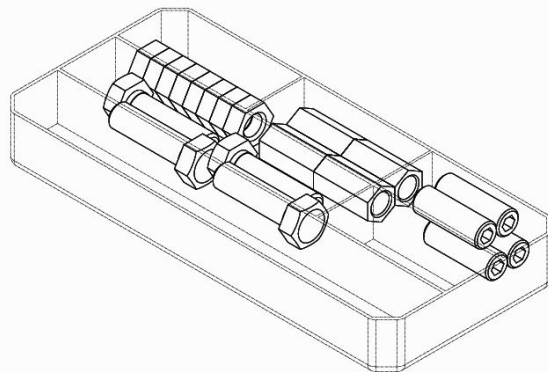

HARDWARE KIT C

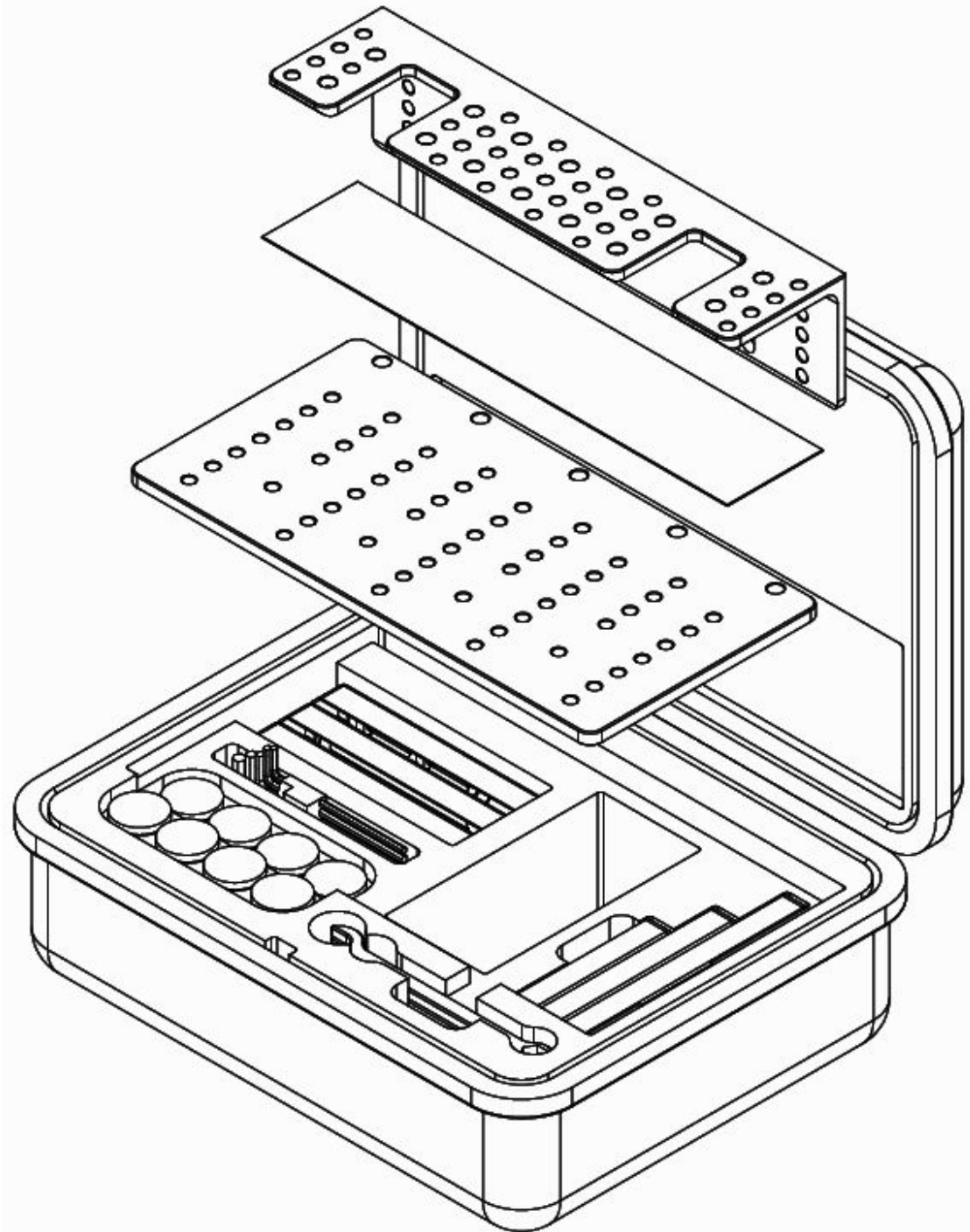



RECOMMENDED PRACTICES

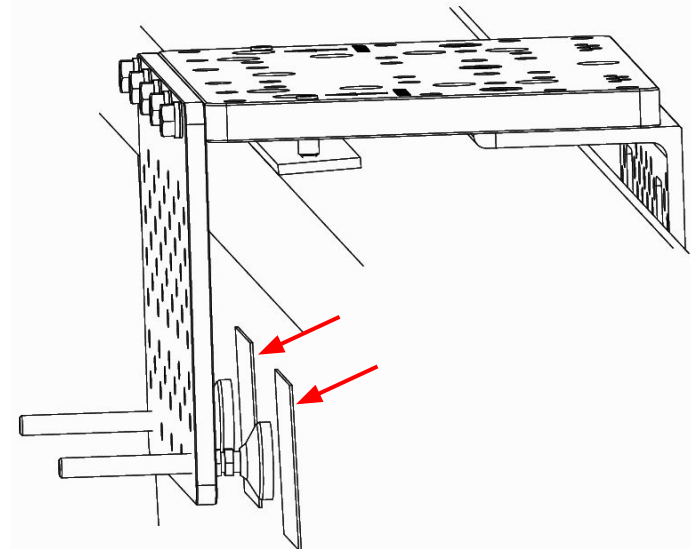
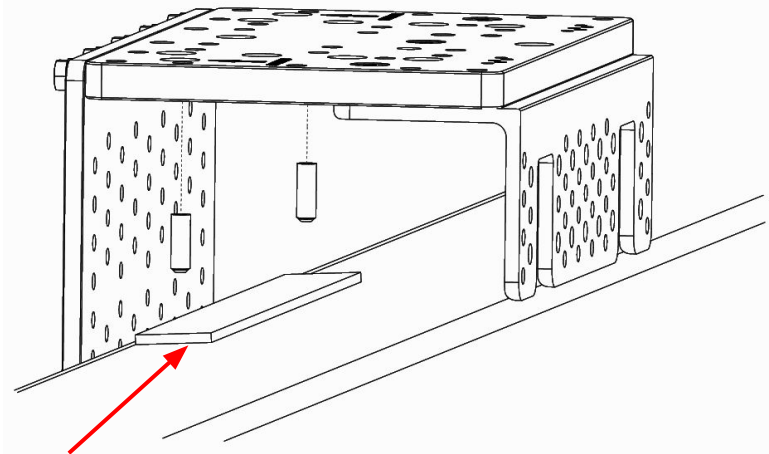

PROTECT VESSEL - Use included protective adhesive tape where appropriate to protect vessel.

STRONG GUNNEL - Tie mount to vessel using with equal force on either side, fore and aft on vessel.

WEAK GUNNEL - Support Mount/gunnel with wood blocks or similar material and add 3rd strap compressing VOOP onto wooden blocks.

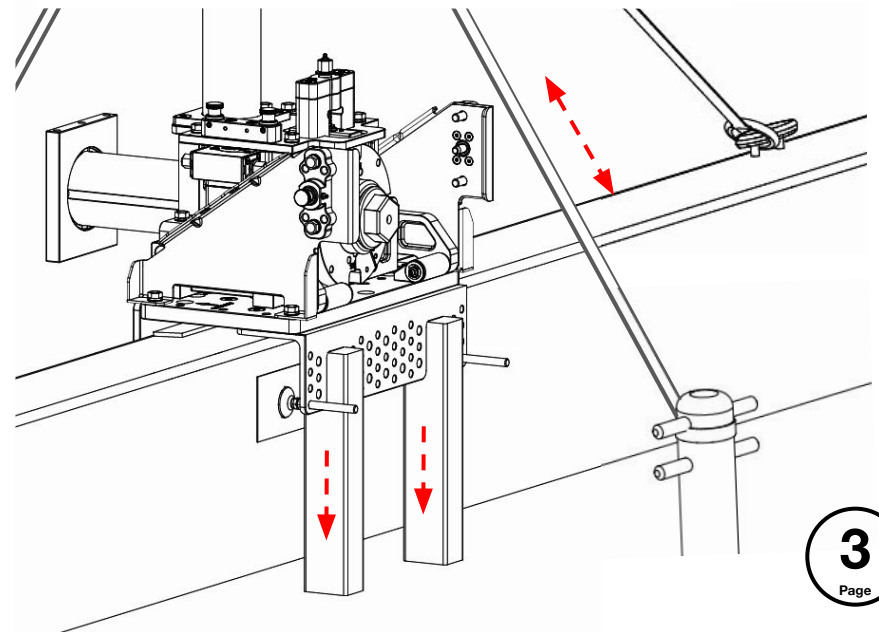
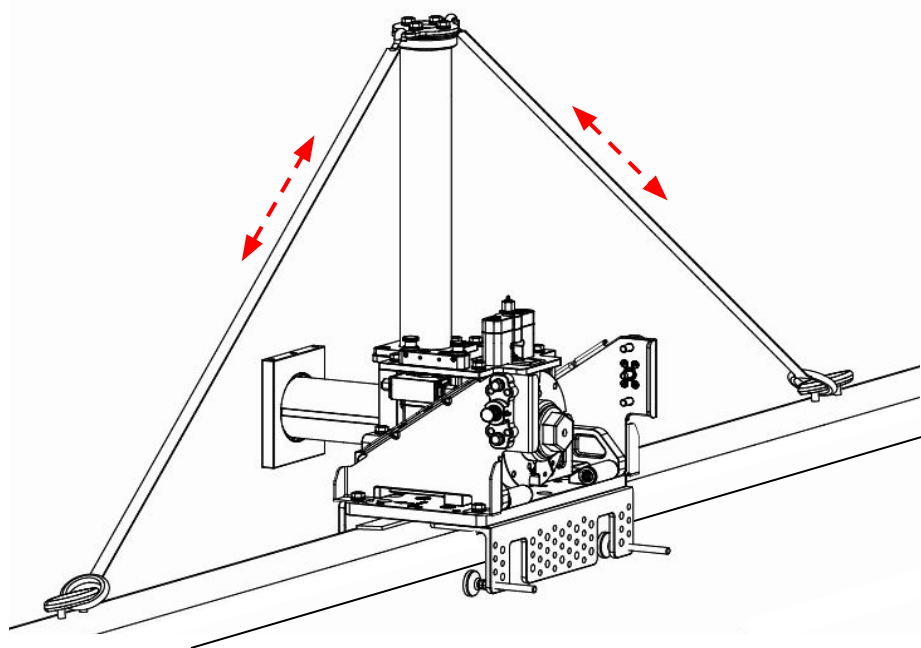



RECOMMENDED PRACTICES

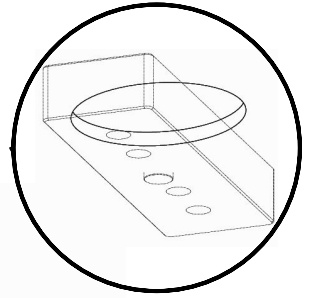
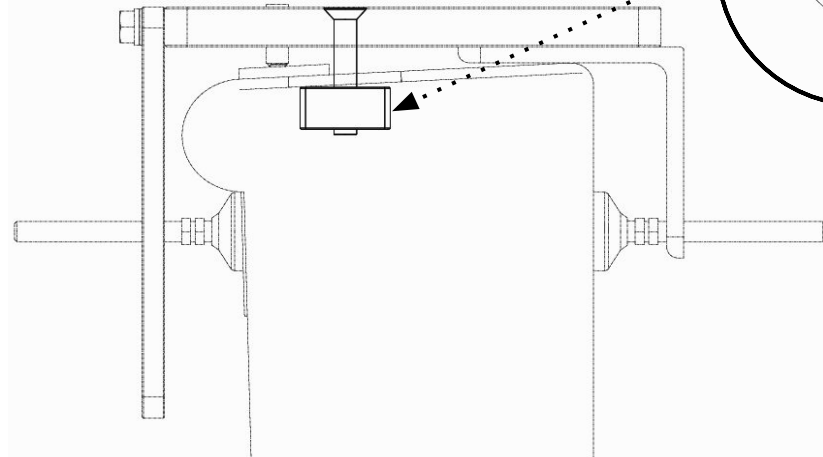
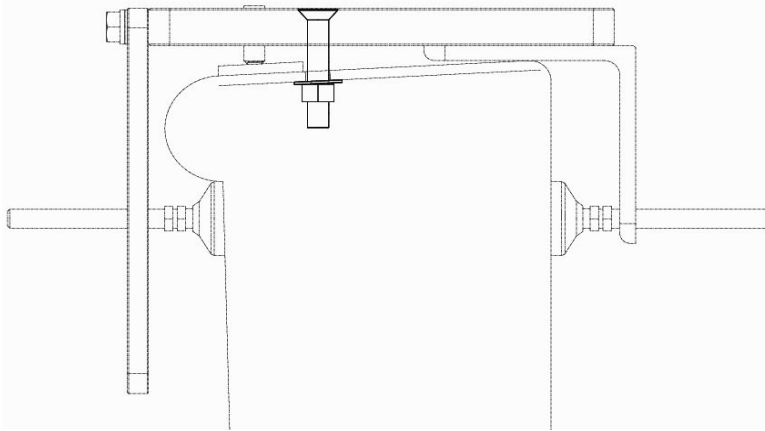

BOLT TO GUNNEL - If possible bolt directly to the gunnel using an existing hole or by drilling new $\frac{1}{2}$ " hole(s).

POSITIVE MOUNTING - If possible connect to gunnel with a positive connection to protruding features.

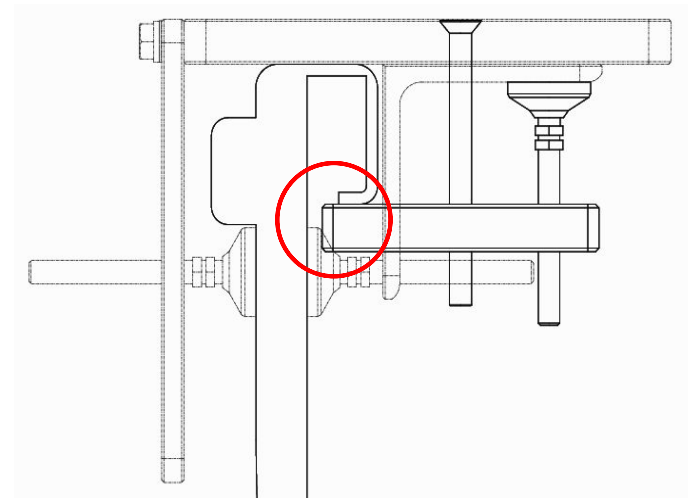
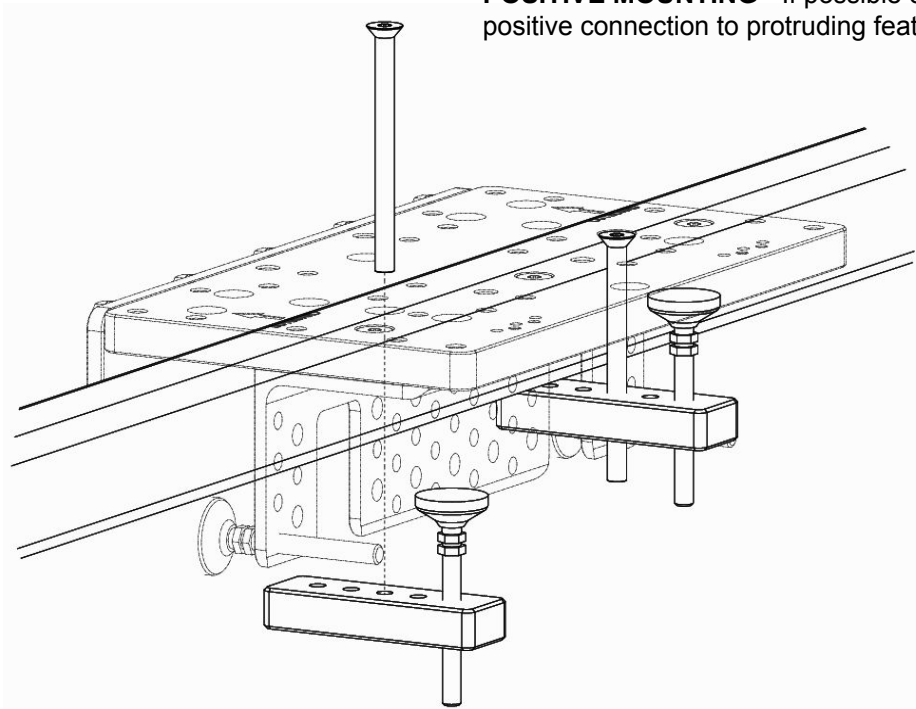



INSTALLATION TIPS: ROLL ANGLE COMPENSATION

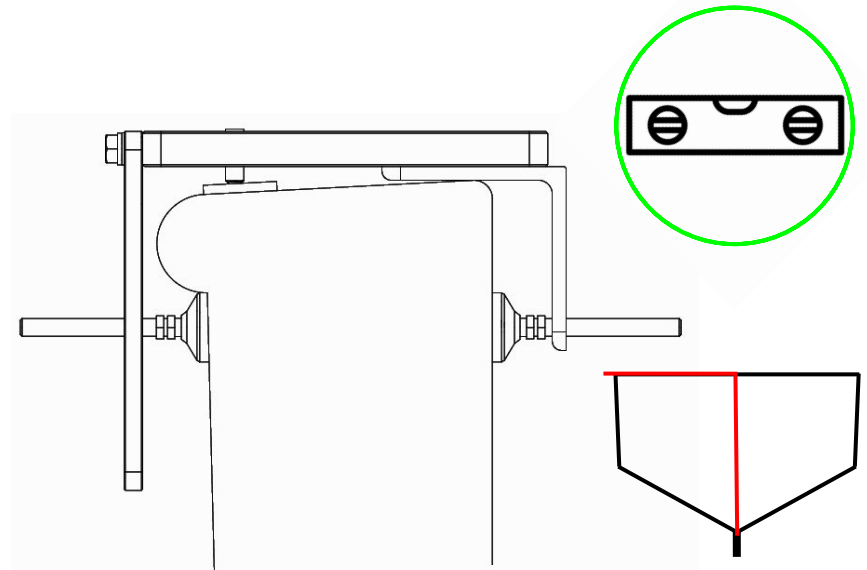
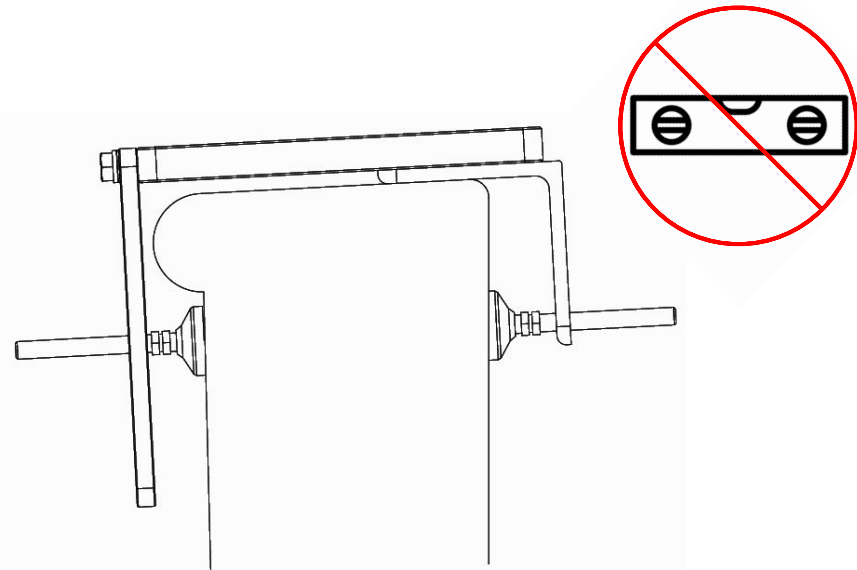

LEVEL BASE PLATE - Orient base plate to be perpendicular with center-line of keel.

LEVEL BASE PLATE - Use the highlighted threaded-holes for leveling-feet or set-screws.

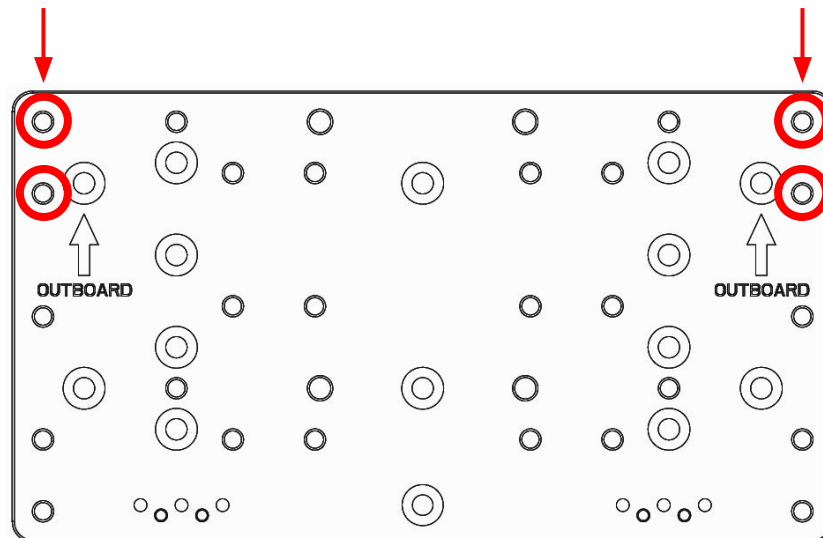
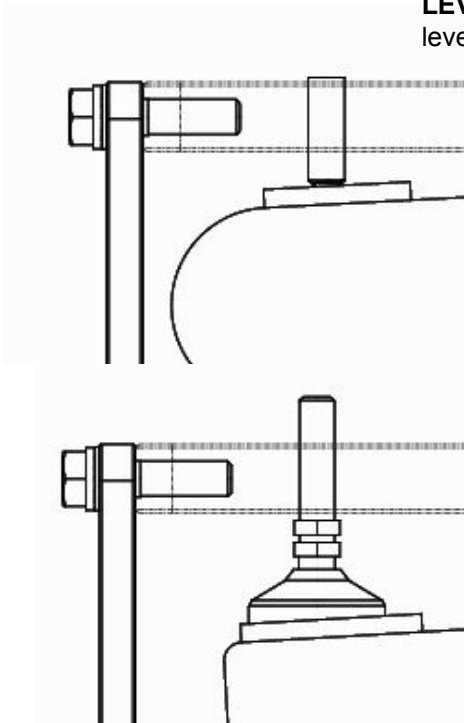



INSTALLATION TIPS: BALANCING CLAMP FORCE

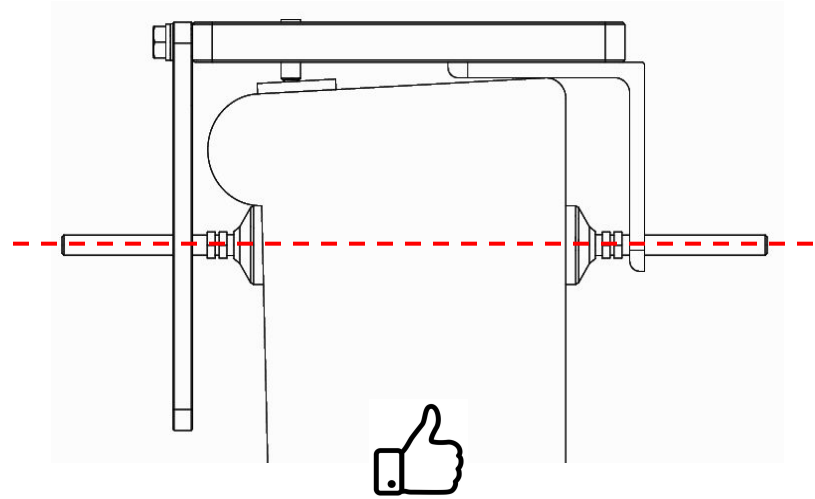
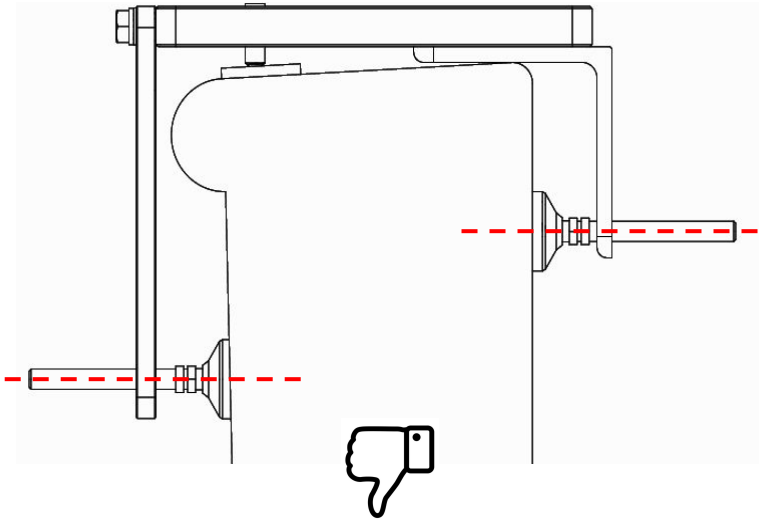

BALANCE FORCES - Whenever possible make sure to orient leveling feet so that they are directly across from each other.

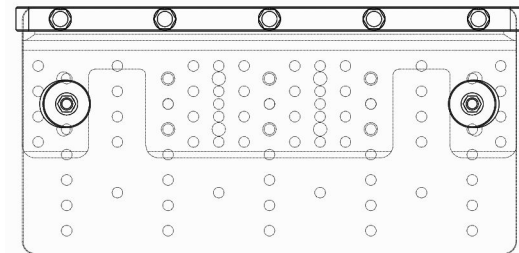
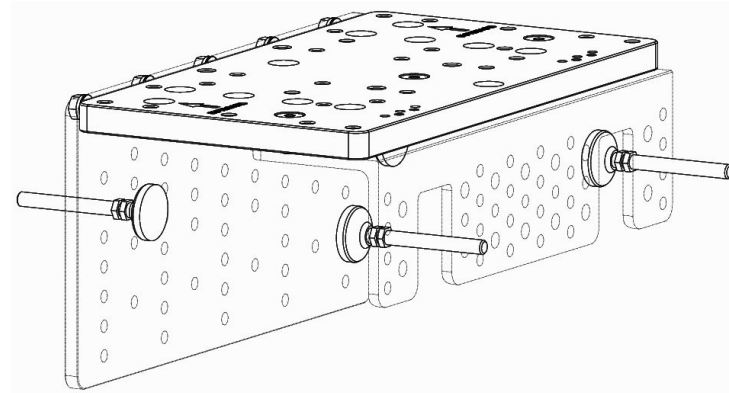
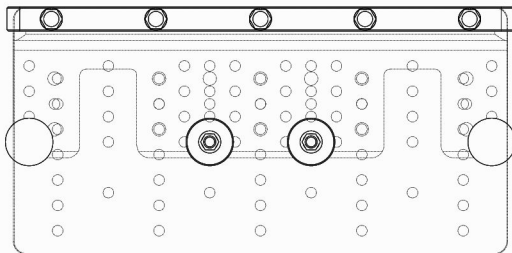
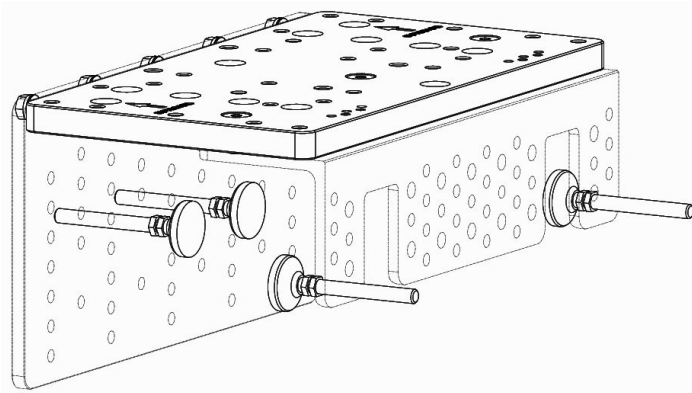



INSTALLATION TIPS: IDEAL POSITIONING

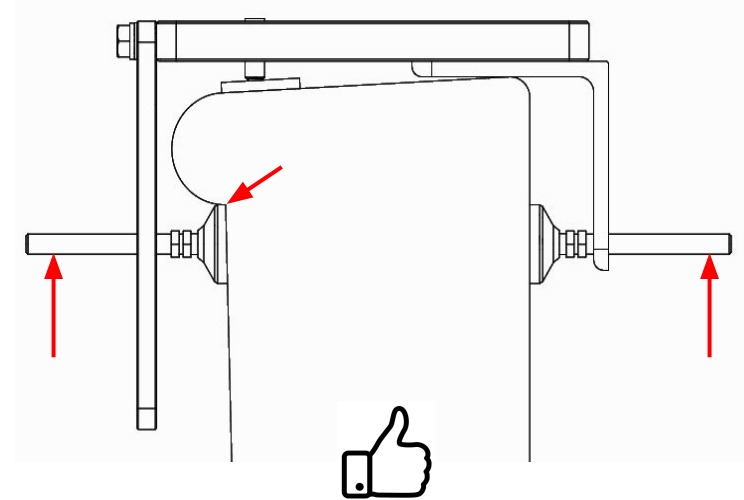
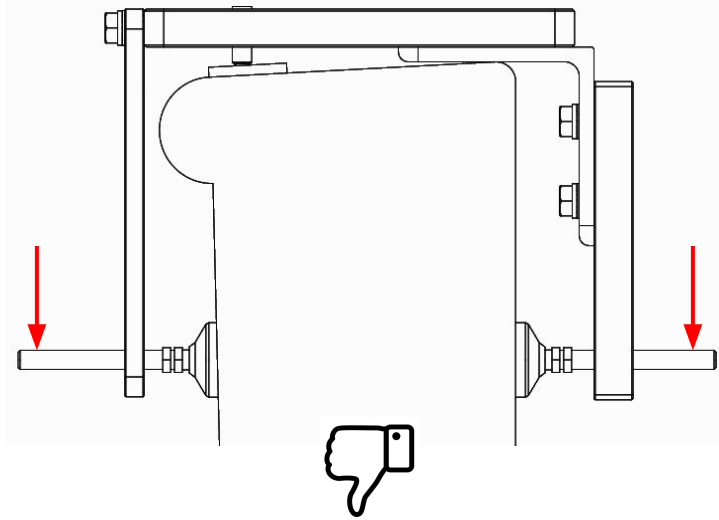

POSITION LEVELING FEET - Always position leveling feet as close to the top of the gunnel as possible.

MINIMAL EXTENSION - Always position plates as close to gunnel as possible.

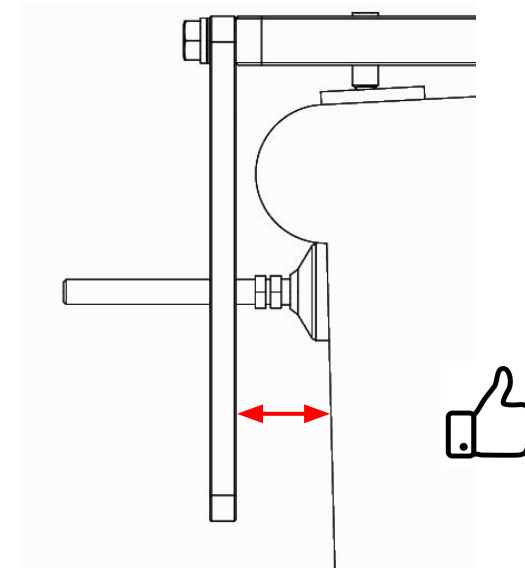
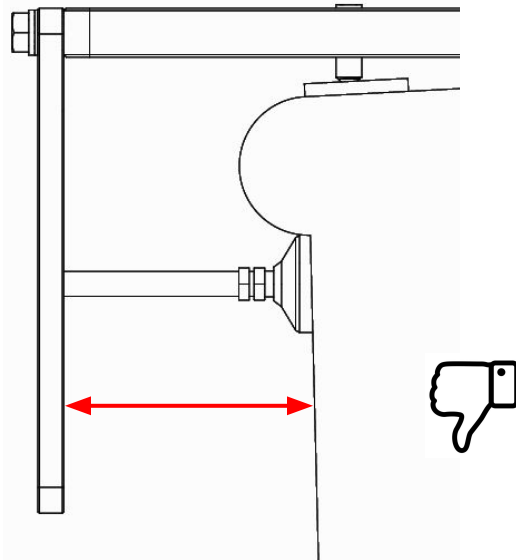



NARROW CONFIGURATION

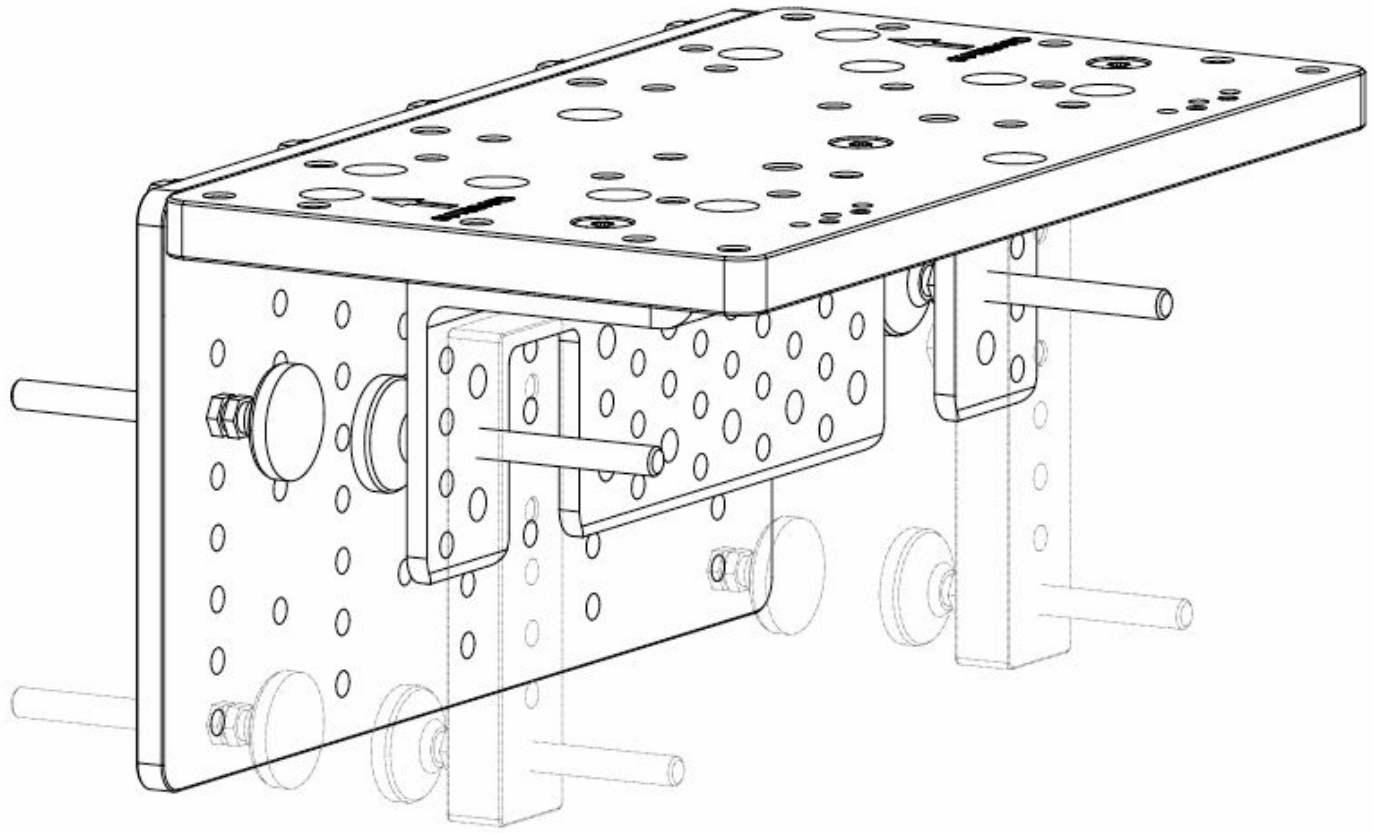



NARROW SETTINGS

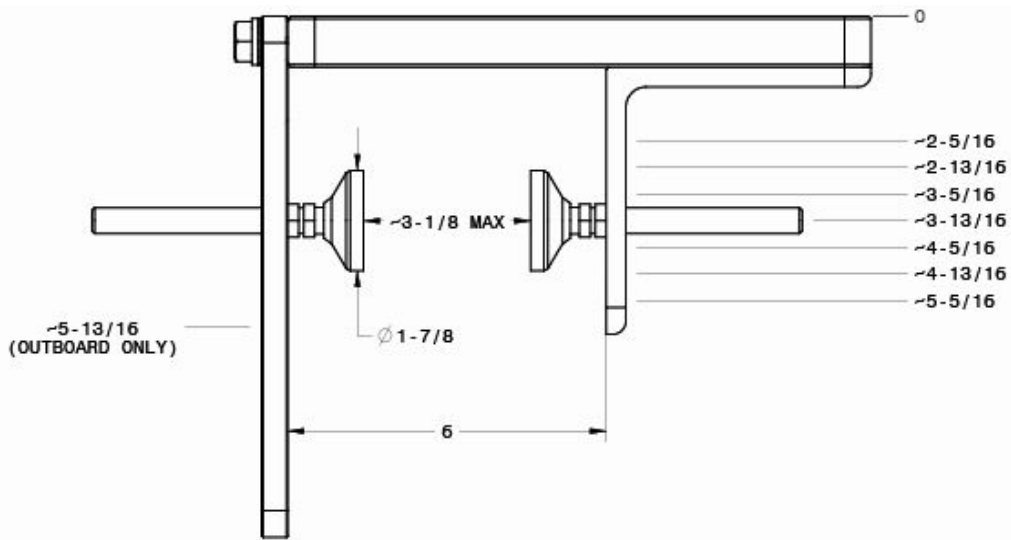

STANDARD

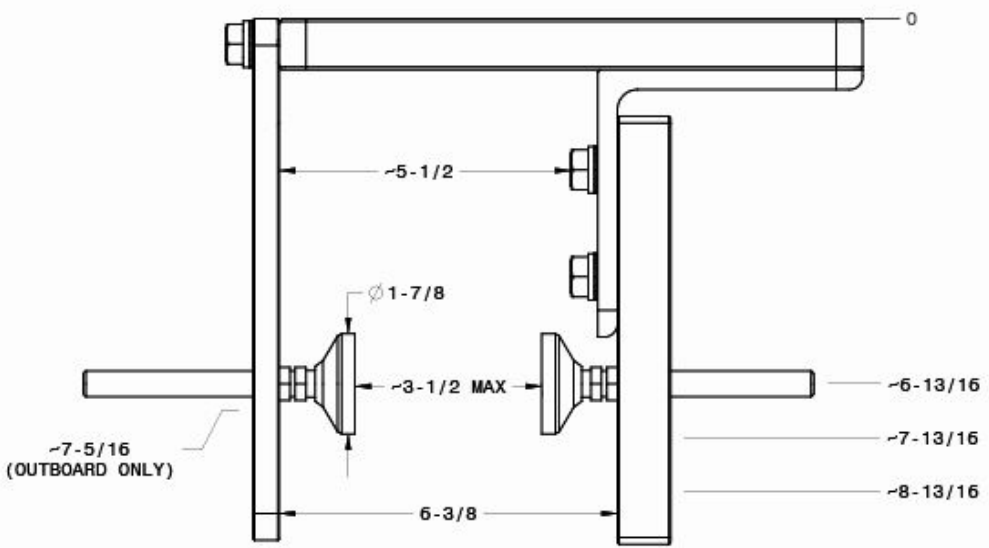

EXTENDED

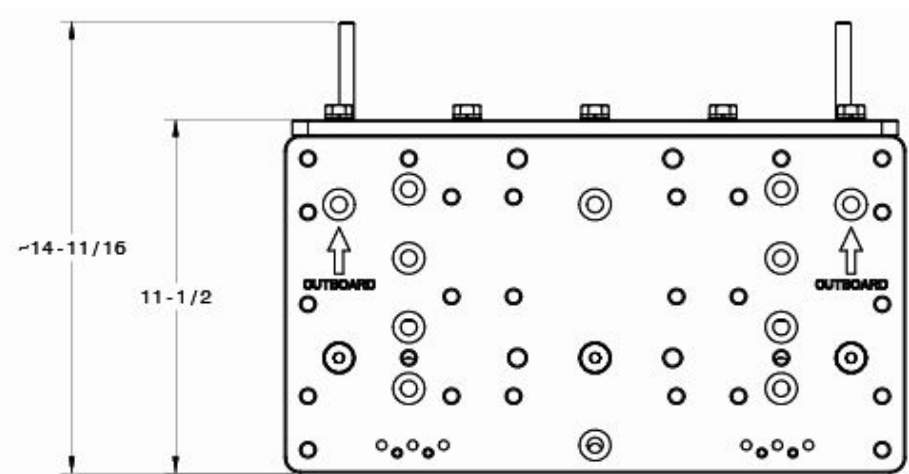

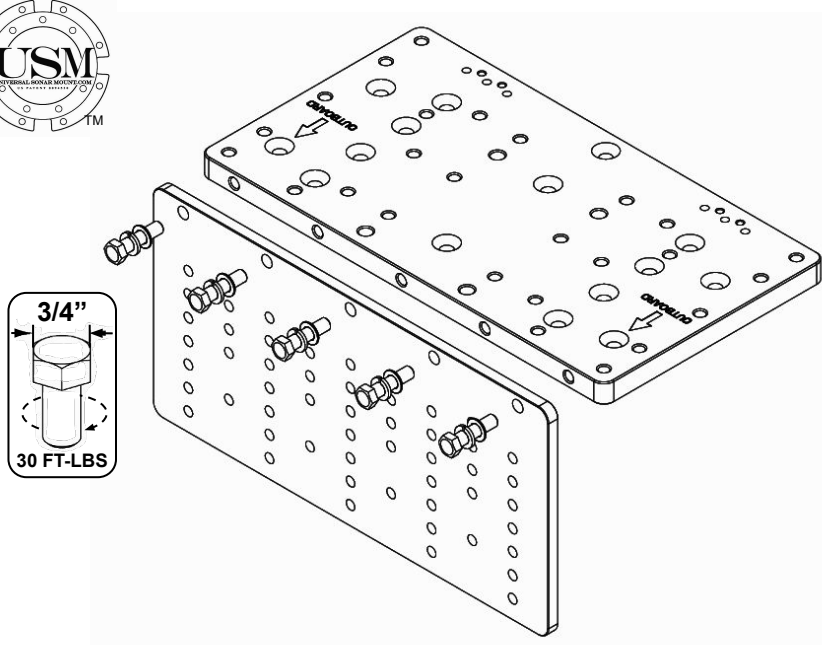

BASE PLATE/OUTBOARD PLATE - Bolt Outboard Plate to Base Plate.

1

ANGLE PLATE/EXTENSION BARS - Bolt Extension Bars to Angle Plate.

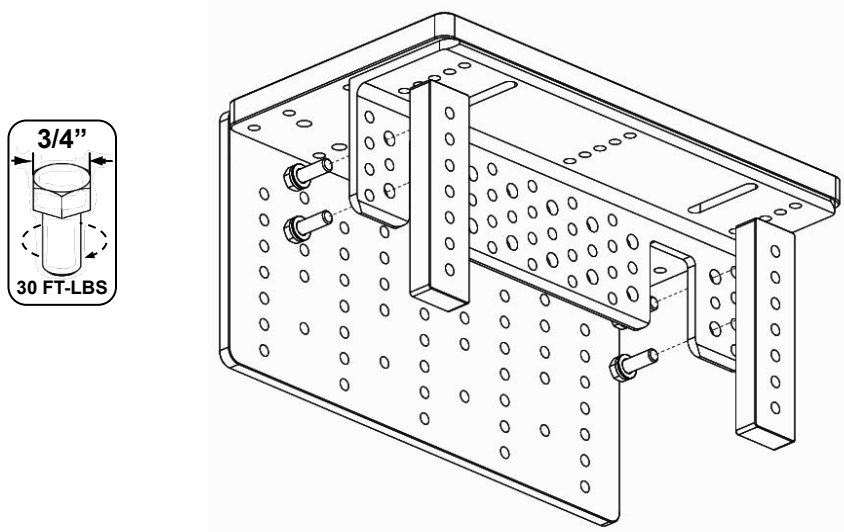

3

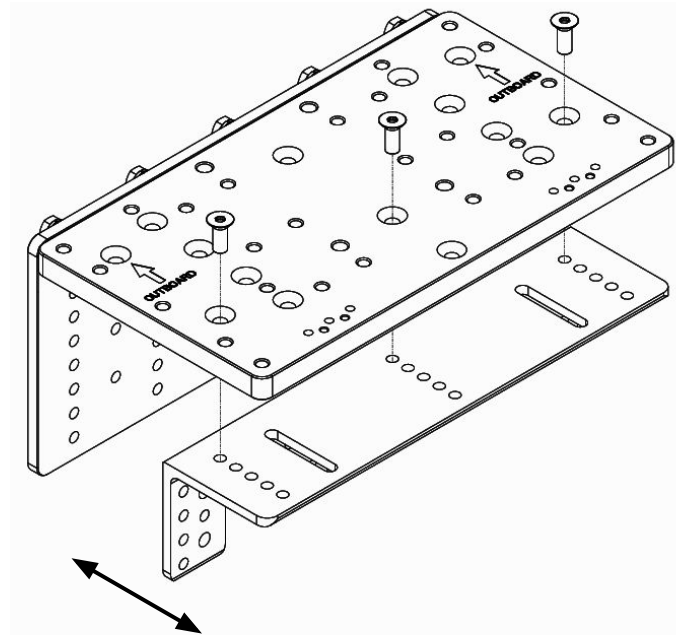
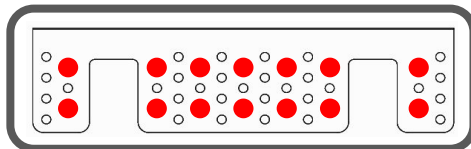

BASE PLATE/ANGLE PLATE - Bolt Angle Plate to Base Plate.

2

INSTALL LEVELING FEET - Install Leveling feet onto Outboard Plate and Extension Bars.

4

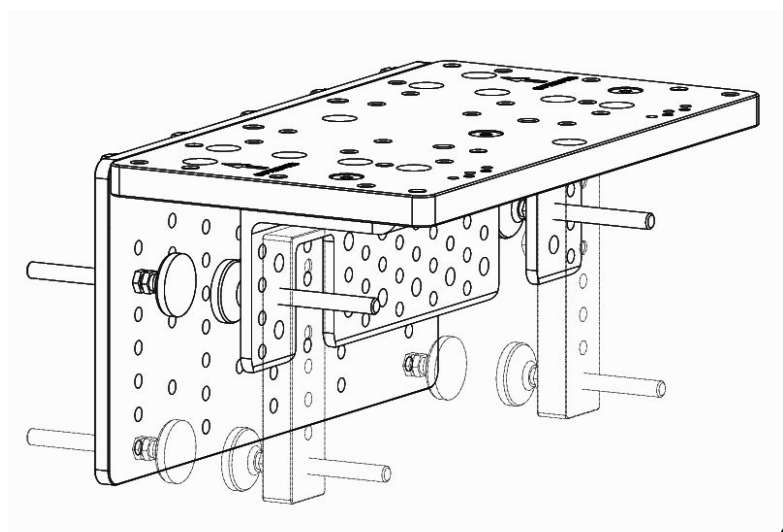



WIDE CONFIGURATION

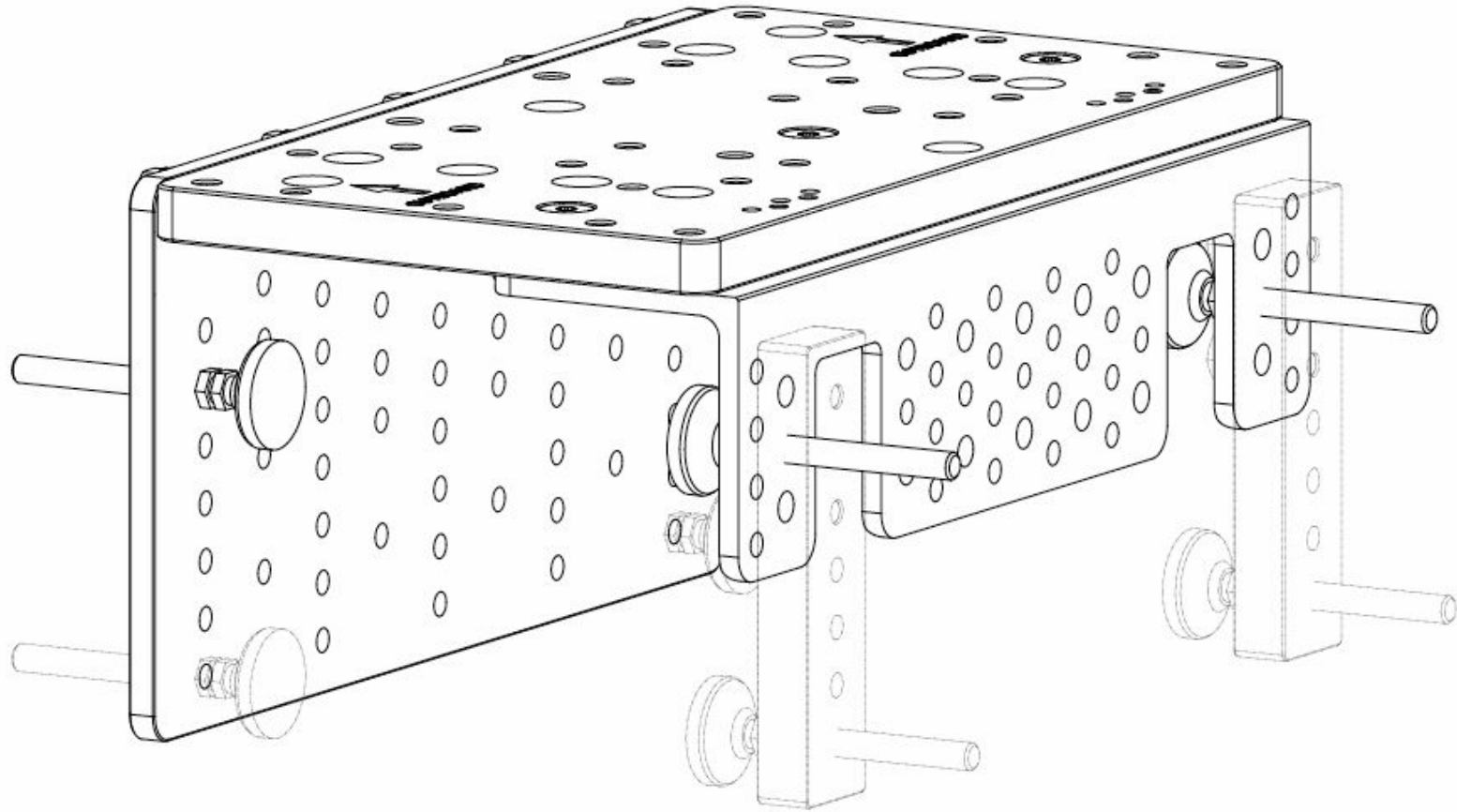



WIDE SETTINGS

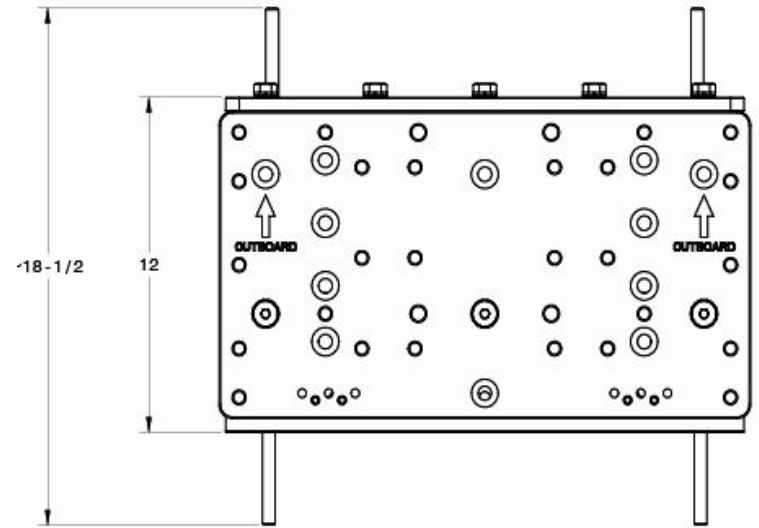
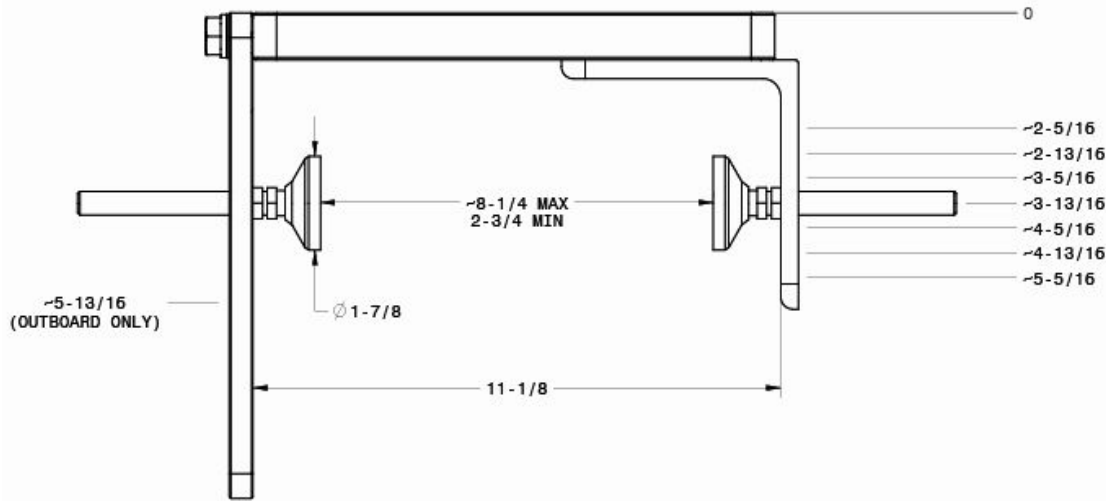

STANDARD

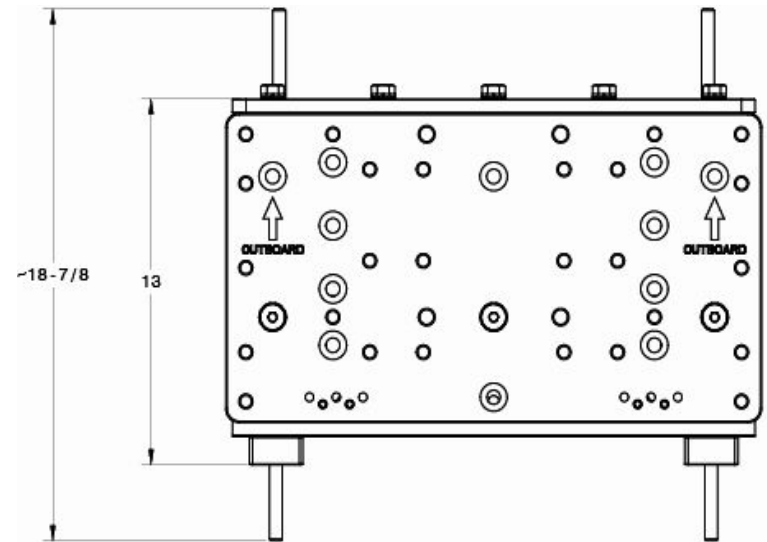
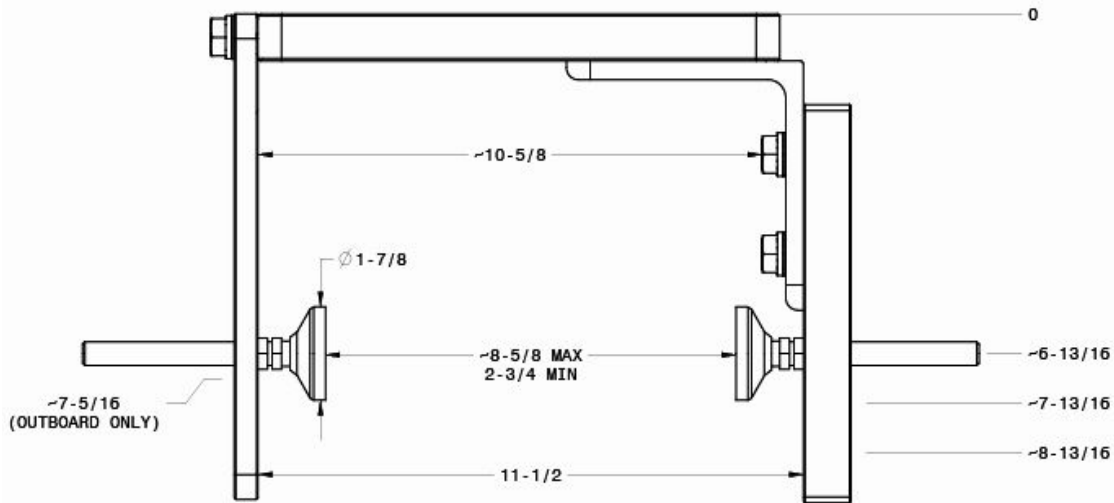

EXTENDED

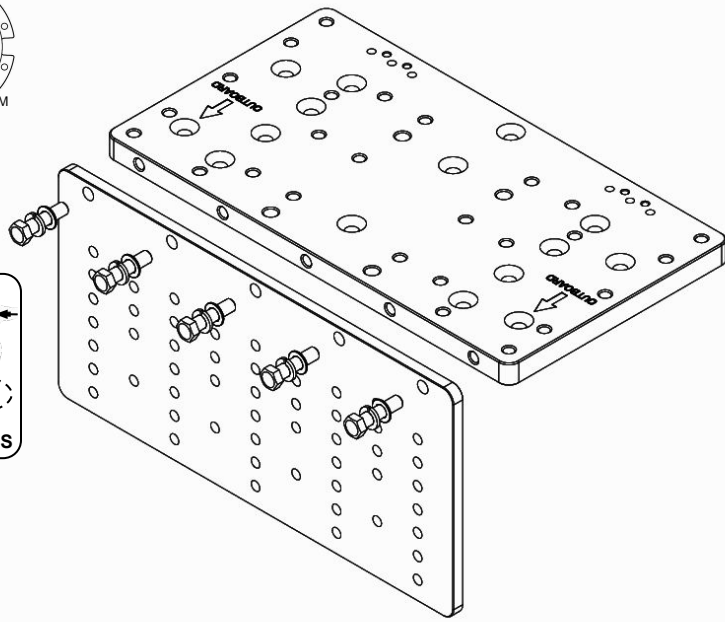
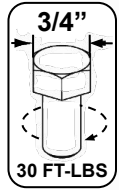

BASE PLATE/OUTBOARD PLATE - Bolt Outboard Plate to Base Plate.

1

ANGLE PLATE/CLAMP BARS - Bolt Extension Bars to Angle Plate.

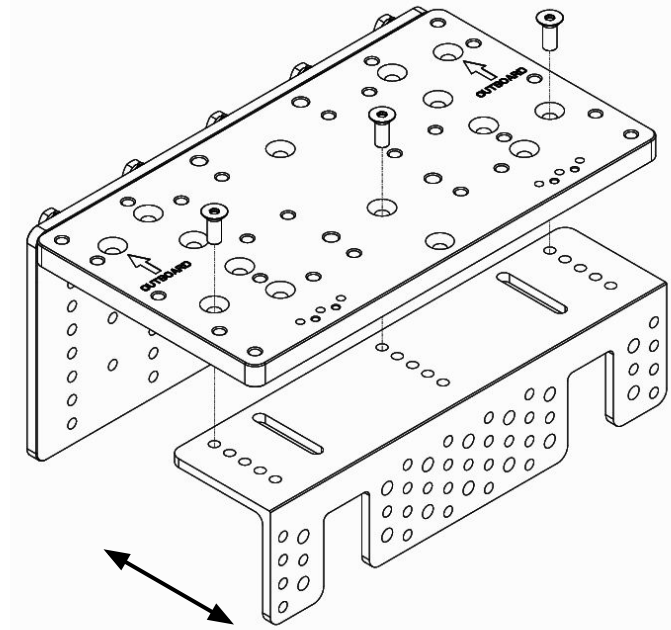
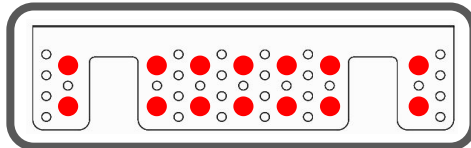
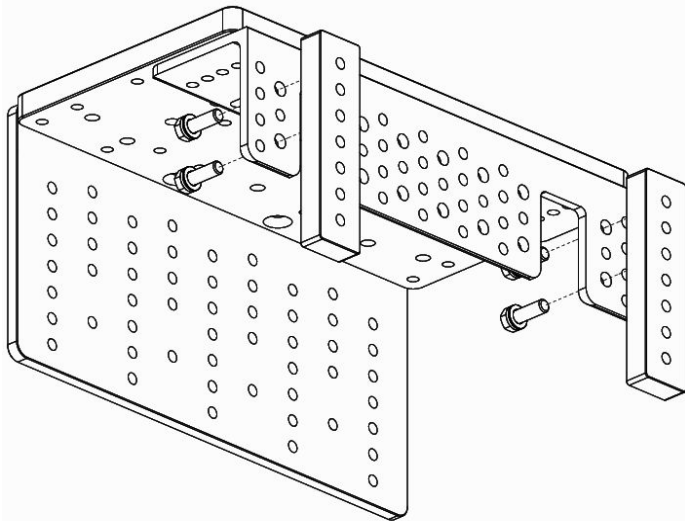
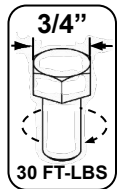

BASE PLATE/ANGLE PLATE - Bolt Angle Plate to Base Plate.

2

INSTALL LEVELING FEET - Install Leveling feet onto Outboard Plate and Extension Bars.

4

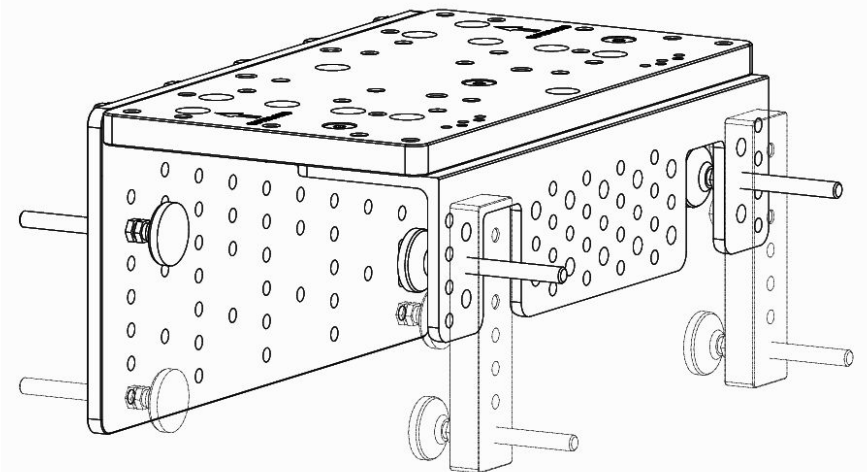
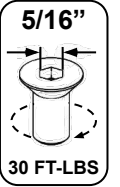



EXTENDED CONFIGURATION

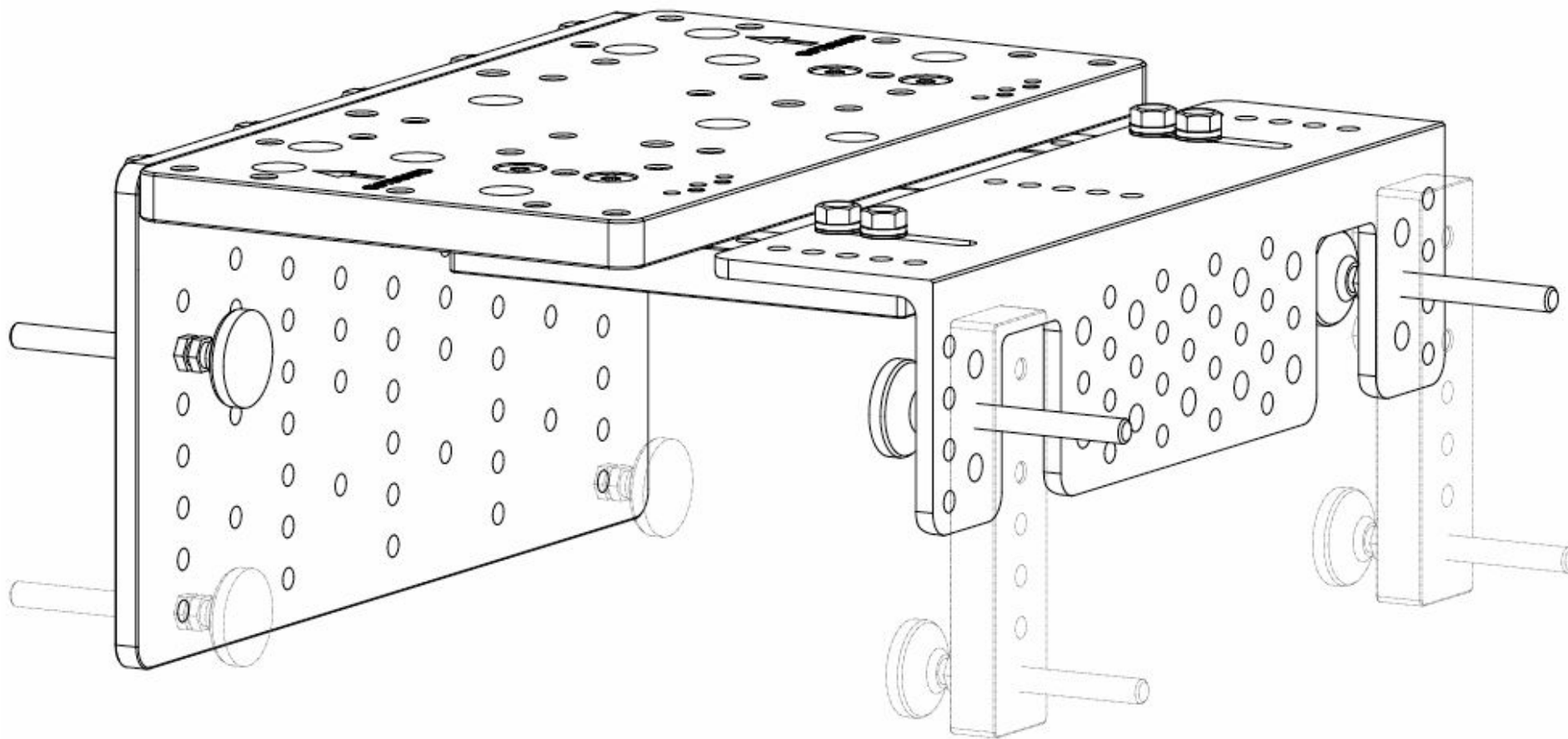



EXTENDED SETTINGS

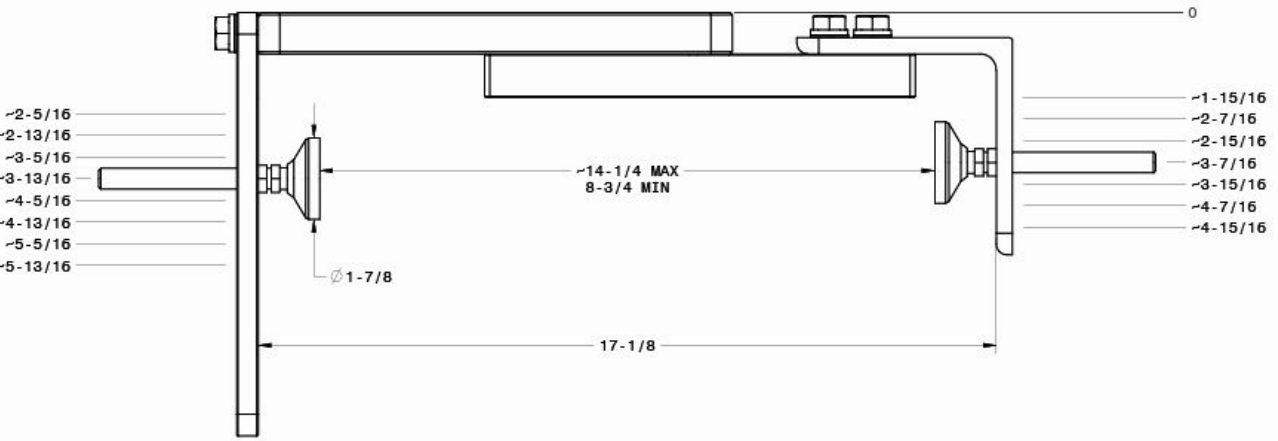

STANDARD

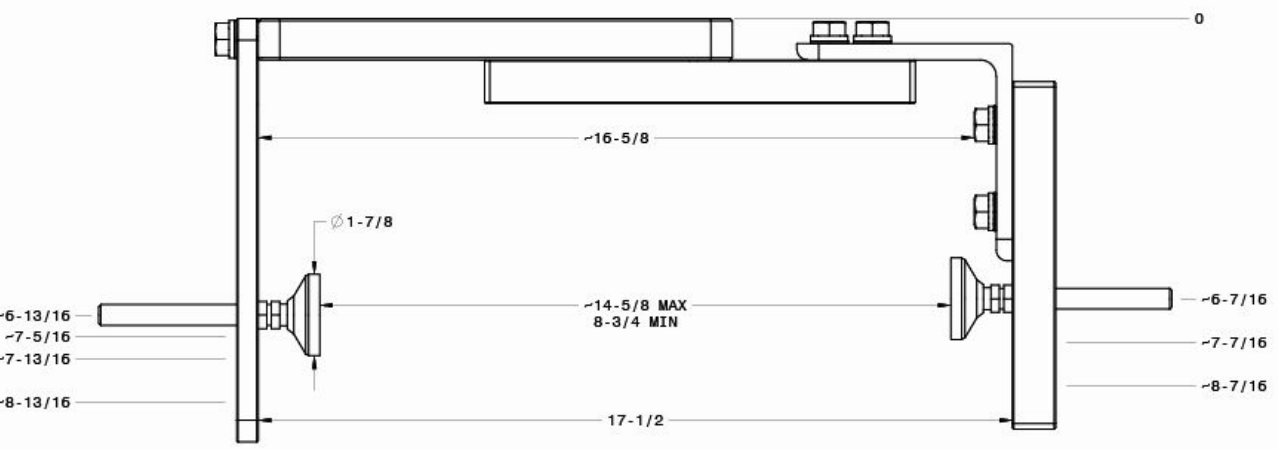
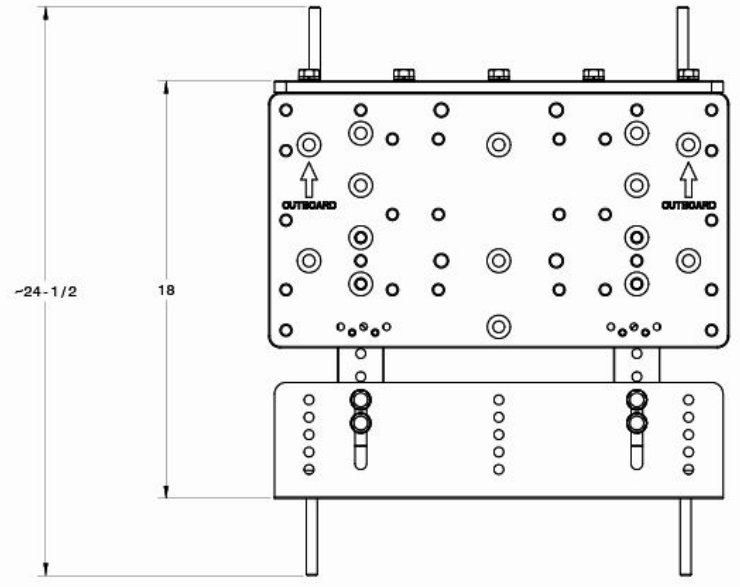

EXTENDED

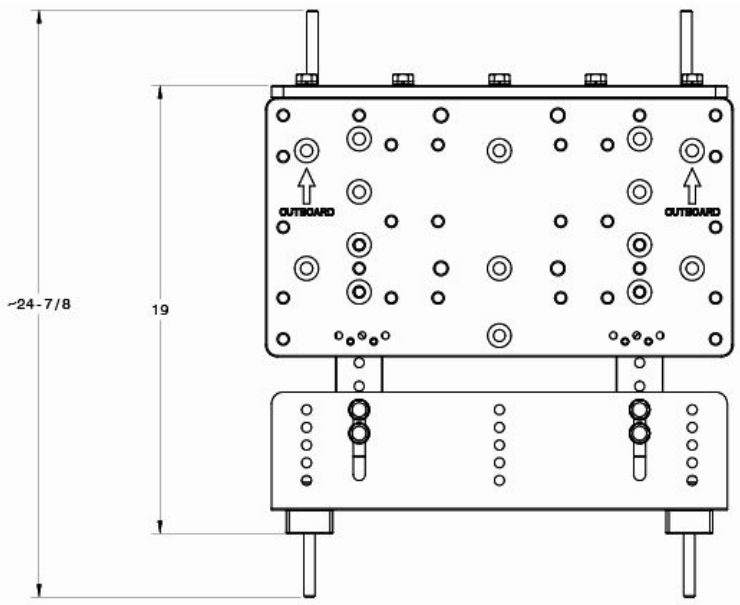

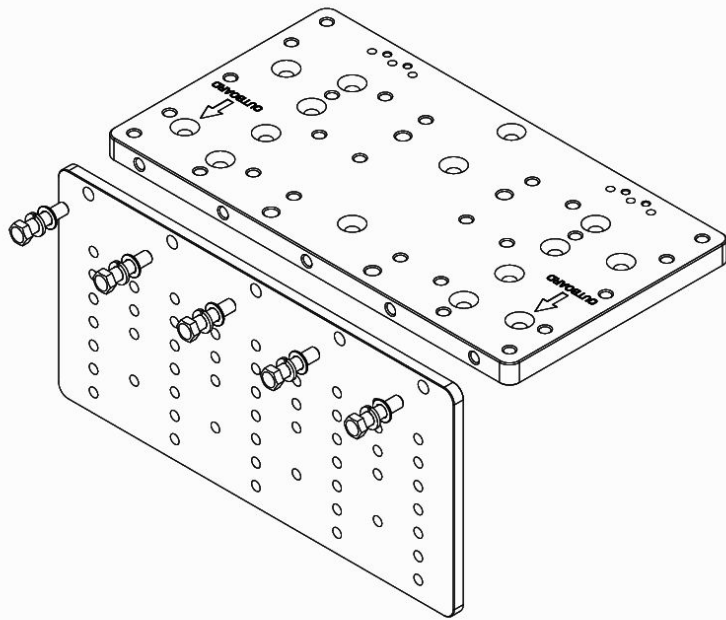
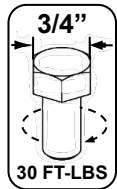

BASE PLATE/OUTBOARD PLATE - Bolt Outboard Plate to Base Plate. 1

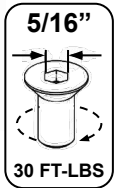
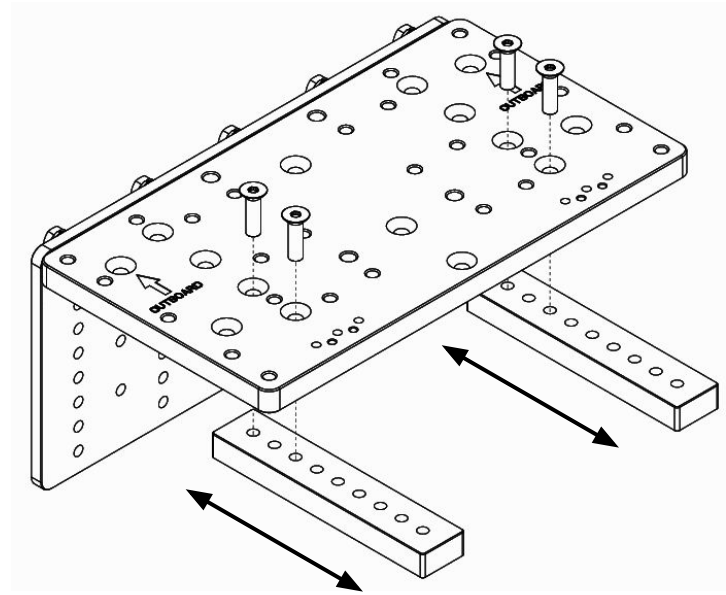

BASE PLATE/ANGLE PLATE - Bolt Angle Plate to Base Plate. 2

ANGLE PLATE/EXTENSION BARS - Bolt Extension Bars to Angle Plate. 3

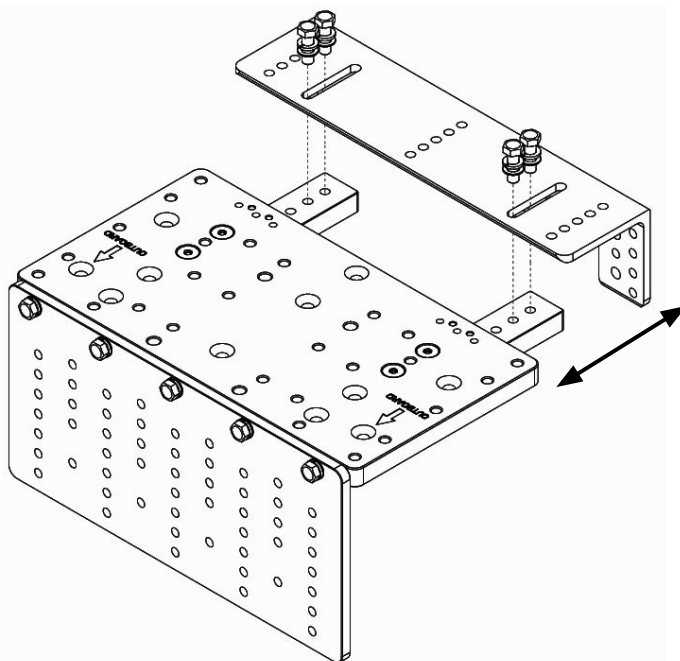
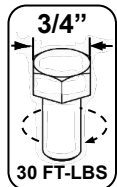

INSTALL LEVELING FEET - Install Leveling feet onto Outboard Plate and Extension Bars. 4

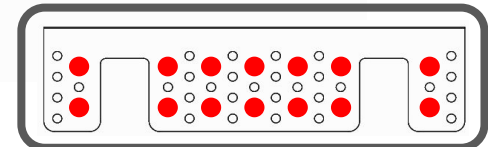
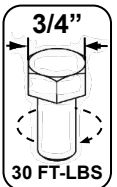
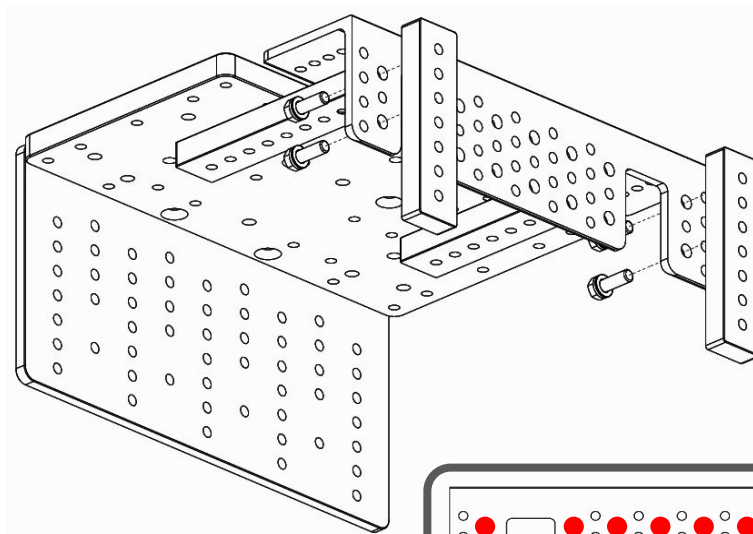

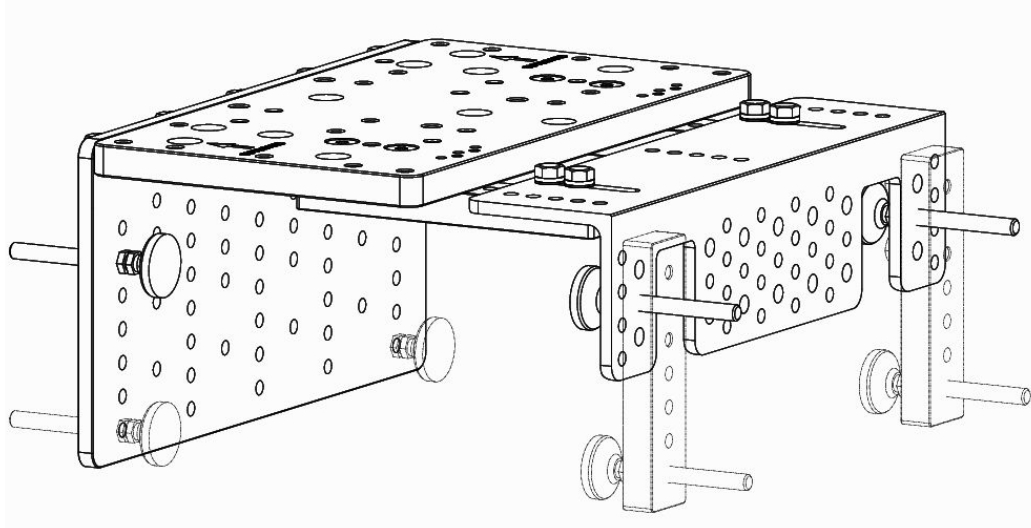

INSTALL LEVELING FEET - Install Leveling feet onto Outboard Plate and Extension Bars.

5

GENERAL MAINTENANCE - Ensure stainless hardware is always coated with a marine grade Grease like Aqua-Shield. Always wash and dry the USM after each use. Afterward apply a silicone spray or lubricant that does not make plastic swell.

AVAILABLE FROM USM FOR MOUNT SERVICE AND MAINTENANCE

- *AQUA-SHIELD GREASE*
- *T-9 BOESHIELD*
- *CMD EXTREME PRESSURE #3 GREASE*
- *BOLT AND SPARES KITS*



4

3

2

1

REVISIONS				
REV	REV	DESCRIPTION	DATE	APPROVED
--	1	INITIAL RELEASE	2022-MAY-17	MZ

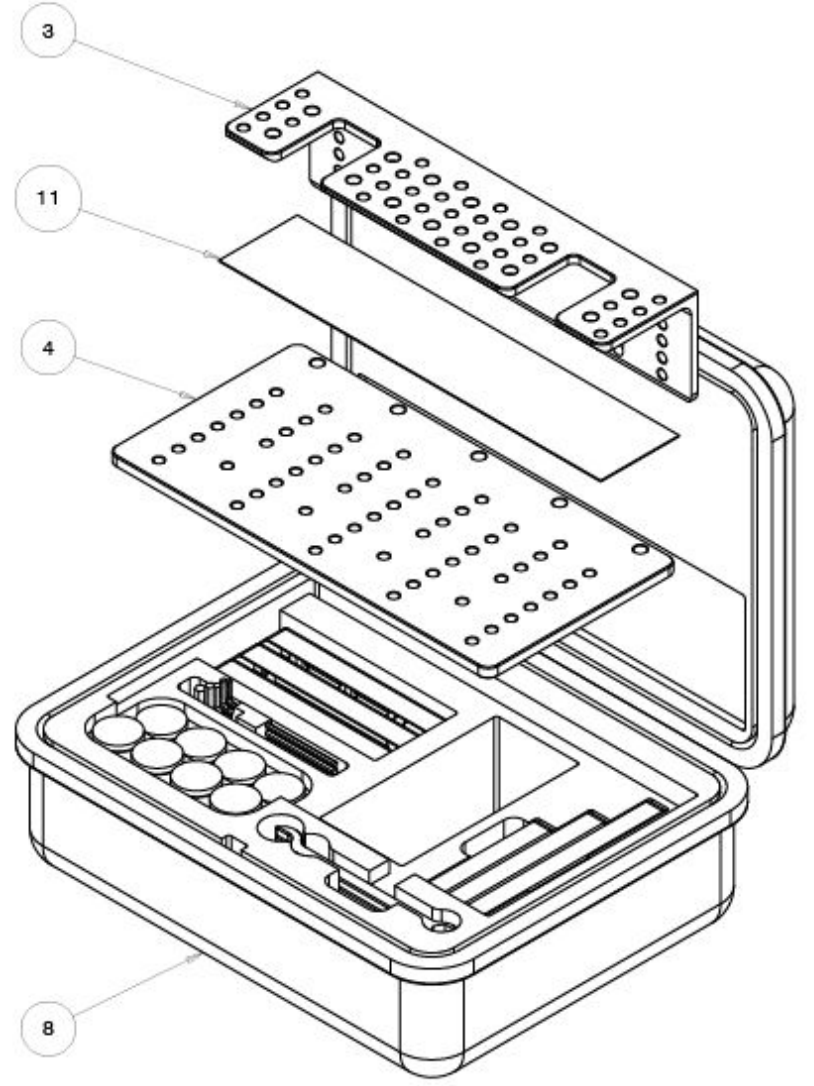
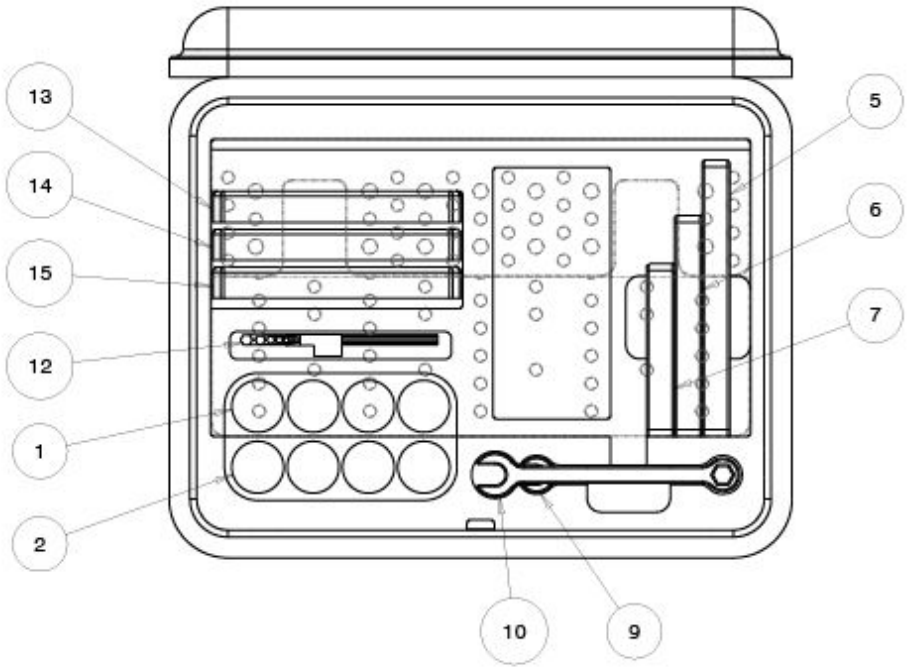

ITEM NO.	QTY	PART NO.	DRAWING TITLE OR DESCRIPTION	MANUFACTURER	MFG PART NO.
15	1	599-4920-SV-C	ASSEMBLY, HARDWARE KIT C, VOOP	ASSY	---
14	1	599-4920-SV-B	ASSEMBLY, HARDWARE KIT B, VOOP	ASSY	---
13	1	599-4920-SV-A	ASSEMBLY, HARDWARE KIT A, VOOP	ASSY	---
12	1	599-4010	ALLEN KEY SET, BALL END	MCMASTER	4091A25
11	1	599-4009	TAPE, NONABRASIVE ANTI-SLIP	MCMASTER	6249T781
10	2	599-4006	COMBINATION WRENCH, 3/4	MCMASTER	5904A51
9	2	599-4007	COMBINATION WRENCH, 5/8	MCMASTER	5904A40
8	1	503-102-1910-C	ASSEMBLY, CASE, VOOP	SKD	31-2015-70-E
7	2	503-1008-08	EXTENSION BAR, SHORT, VOOP	FAB	---
6	2	503-1008-02	EXTENSION BAR, MEDIUM, VOOP	FAB	---
5	2	503-1008-01	EXTENSION BAR, LONG, VOOP	FAB	---
4	1	503-1002	OUTBOARD PLATE, VOOP	FAB	---
3	1	503-1001	ANGLE PLATE, VOOP	FAB	---
2	4	94-511-1075-5000-4000-700-20	LEVELING MNT, SWVL, 1/2-13UNC X 4.0, SST	MCMASTER	6111K92
1	4	94-511-1075-5000-2000-700-20	LEVELING MNT, SWVL, 1/2-13UNC X 2.0, SST	MCMASTER	6111K62

UNLESS OTHERWISE SPECIFIED DIMENSIONS ARE IN INCHES.	UNLESS OTHERWISE SPECIFIED DIMENSIONS ARE IN INCHES.	UNLESS OTHERWISE SPECIFIED DIMENSIONS ARE IN INCHES.	UNLESS OTHERWISE SPECIFIED DIMENSIONS ARE IN INCHES.
TOLERANCES ARE: .X +/- 0.1 .XX +/- 0.01 .XXX +/- 0.001 ANGLES +/- 0.5	UNLESS OTHERWISE SPECIFIED DIMENSIONS ARE IN INCHES. CNSD MATERIAL CNSD FINISH CNSD VOLUME CNSD DRAWING FILE NAME	UNLESS OTHERWISE SPECIFIED DIMENSIONS ARE IN INCHES. CNSD REPORTED PARAMETERS 77.284 2435.913 503-102-9910	UNLESS OTHERWISE SPECIFIED DIMENSIONS ARE IN INCHES. DESIGNER M ZAGSD 2022-MAY-17 DRAFTER M ZAGSD 2022-MAY-17 CHECKER --- 2022-MAY-02 DO NOT SCALE DRAWING

UNIVERSAL SONAR MOUNT			
ASSEMBLY, VOOP CASE			
SIZE	CUSTOMER DRAWING/PART NO.	REV	
C	---	1	
SCALE	DRAWING/PART NO.		
0.300	503-102-9910		
		SHEET 1 OF 4	

4

3

2

1

ORDER DRAWING NO. ---
 DRAWING PART NO. 503-102-9910
 REV 1
 REV 1

A

4

3

2

1

 REVISIONS
 SEE SHEET 1

VOOP HARDWARE KIT A

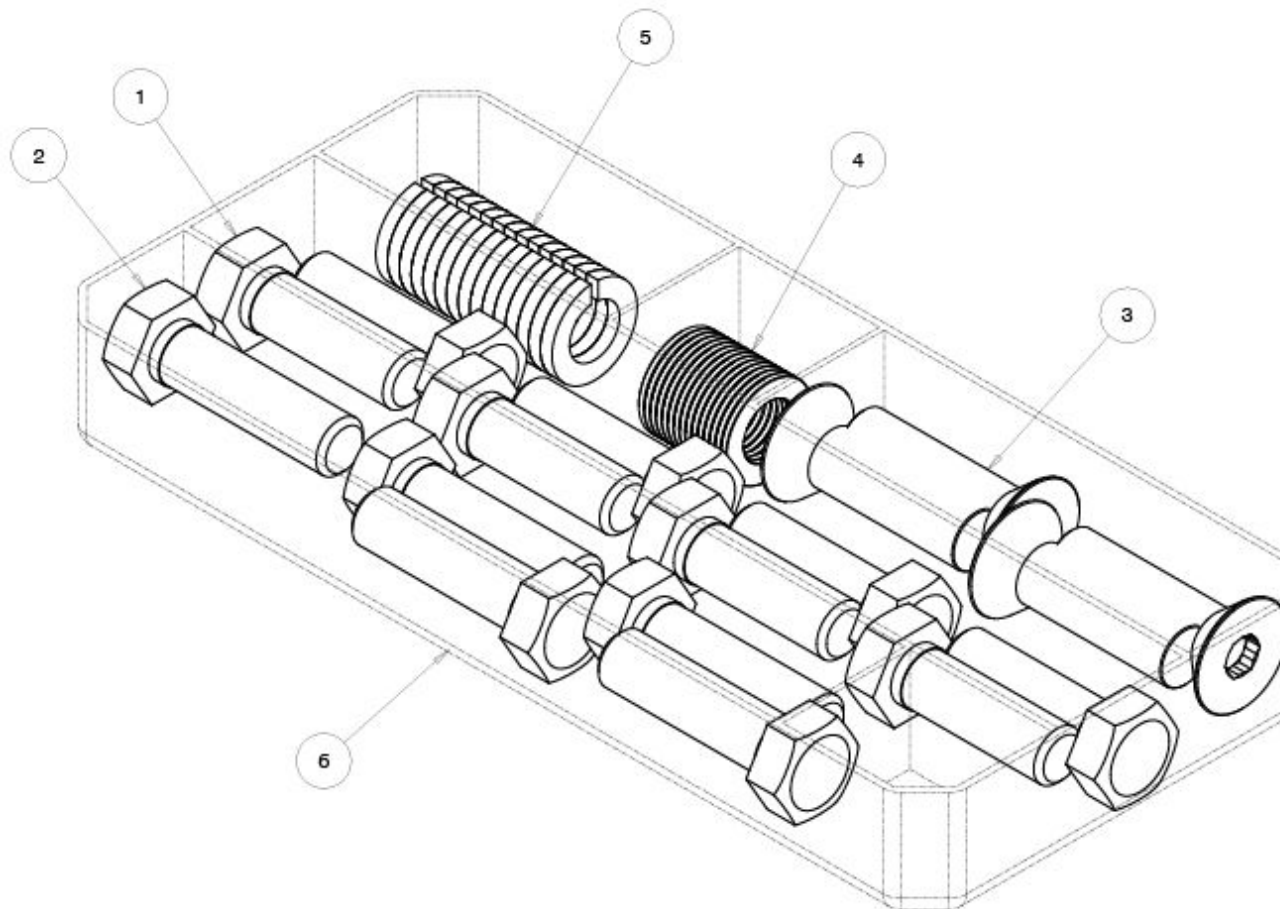

ITEM NO.	QTY.	PART OR IDENTIFYING NO.	DRAWING TITLE OR DESCRIPTION	MANUFACTURER	MFG PART NO.
6	1	699-4020-0V-A	HARDWARE BOX A, STD VOOP	FLAMBEAU	T3003
5	15	90-810-510-870-120-20	WASHER, SPLIT LOCK .510 ID X .07 X .120TK, SST	MCMABSTER	92146A083
4	15	90-300-515-875-060-20	WASHER, .515 ID X .075 OD X .060 TH, SST	MCMABSTER	90017A210
3	4	90-110-500C-1750-20	SCREW, 1/2-13 UNC X 1.75 FMC 18-8	MCMABSTER	92240A718
2	5	90-104-500C-1750-20	HEX BOLT, 1/2-13 X 1.750 SST 18-8	MCMABSTER	92240A718
1	5	90-104-500C-1500-20	HEX BOLT, 1/2-13 X 1.500 SST 18-8	MCMABSTER	92240A715

UNIVERSAL SONAR MOUNT

ASSEMBLY, VOOP CASE

SIZE	CUSTOMER ORDER/PART NO.	REV
C	503-102-9910	1
SCALE	0.300	SHEET 2 OF 4

 ORDER DRAWING PART NO. ---
 DRAWING PART NO. 503-102-9910

 REV. 1
 REV. 2

4

3

2

1

4

3

2

1

REVISIONS
SEE SHEET 1

VOOP HARDWARE KIT B

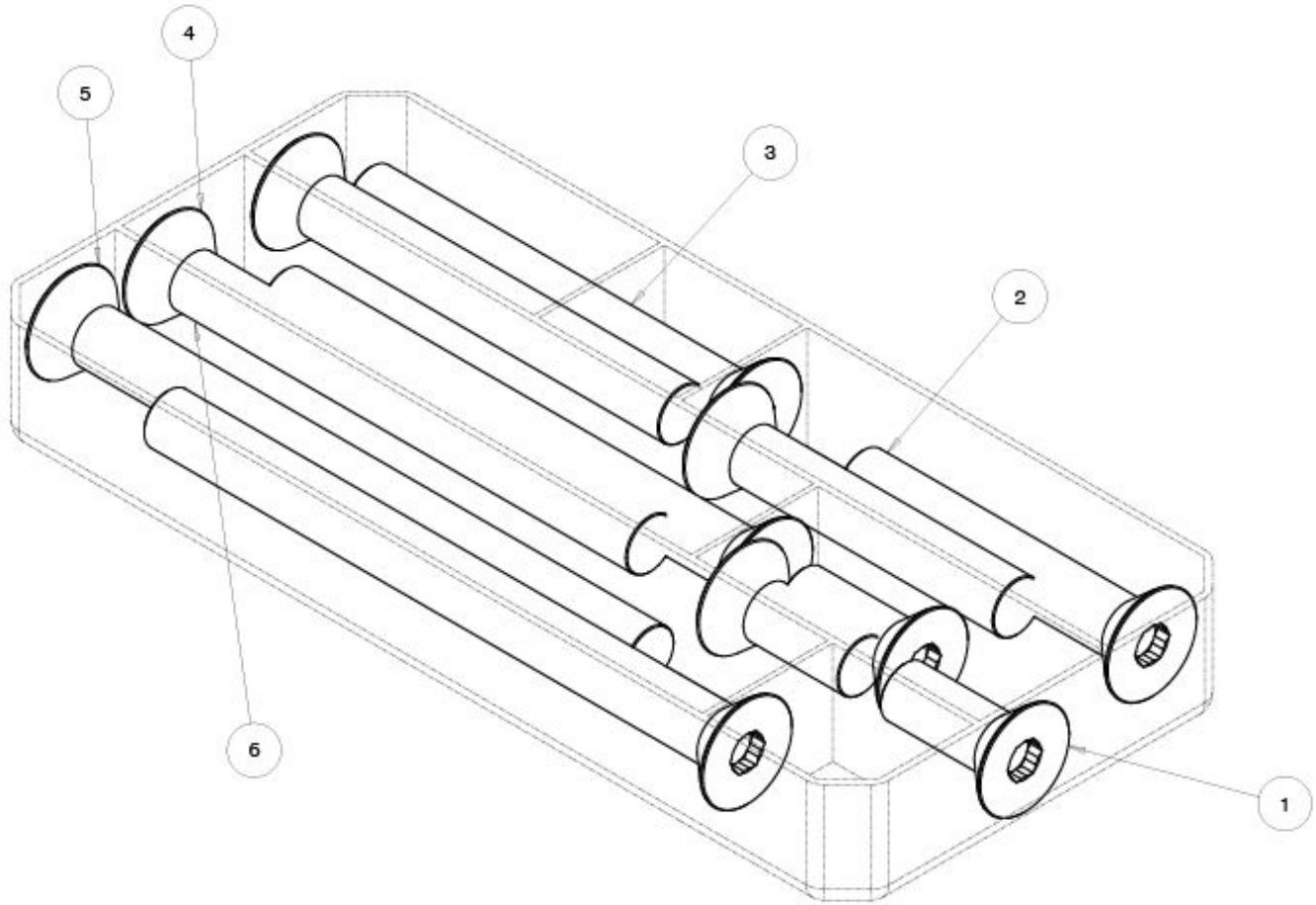

6	1	699-4020-0V-B	HARDWARE BOX B, STD VOOP	FLAMBEAU	T3003
5	2	90-110-500C-6000-20	SCREW, 1/2-13 UNC X 6.0 FHC 15-5	MCMABSTER	92210A784
4	2	90-110-500C-5000-20	SCREW, 1/2-13 UNC X 5.0 FHC 15-5	MCMABSTER	92210A782
3	2	90-110-500C-4000-20	SCREW, 1/2-13 UNC X 4.0 FHC 15-5	MCMABSTER	92210A726
2	2	90-110-500C-3000-20	SCREW, 1/2-13 UNC X 3.0 FHC 15-5	MCMABSTER	92210A724
1	3	90-110-500C-1250-20	SCREW, 1/2-13 UNC X 1.25 FHC 15-5	MCMABSTER	92210A714
ITEM NO.	QTY. REQD.	PART OR IDENTIFYING NO.	DRAWING TITLE OR DESCRIPTION	MANUFACTURER	MFG PART NO.

UNIVERSAL SONAR MOUNT

ASSEMBLY, VOOP CASE

SIZE	CUSTOMER DRAWING/PART NO.	REV
C	---	1
	DRAWING/PART NO.	
	503-102-9910	
SCALE	0.300	SHEET 3 OF 4

ORDER DRAWING/PART NO. ---
 DRAWING/PART NO. 503-102-9910
 REV. 1
 REV. 3

4

3

2

1

D

D

C

B

A

A

4

3

2

1

REVISIONS
SEE SHEET 1

VOOP HARDWARE KIT C

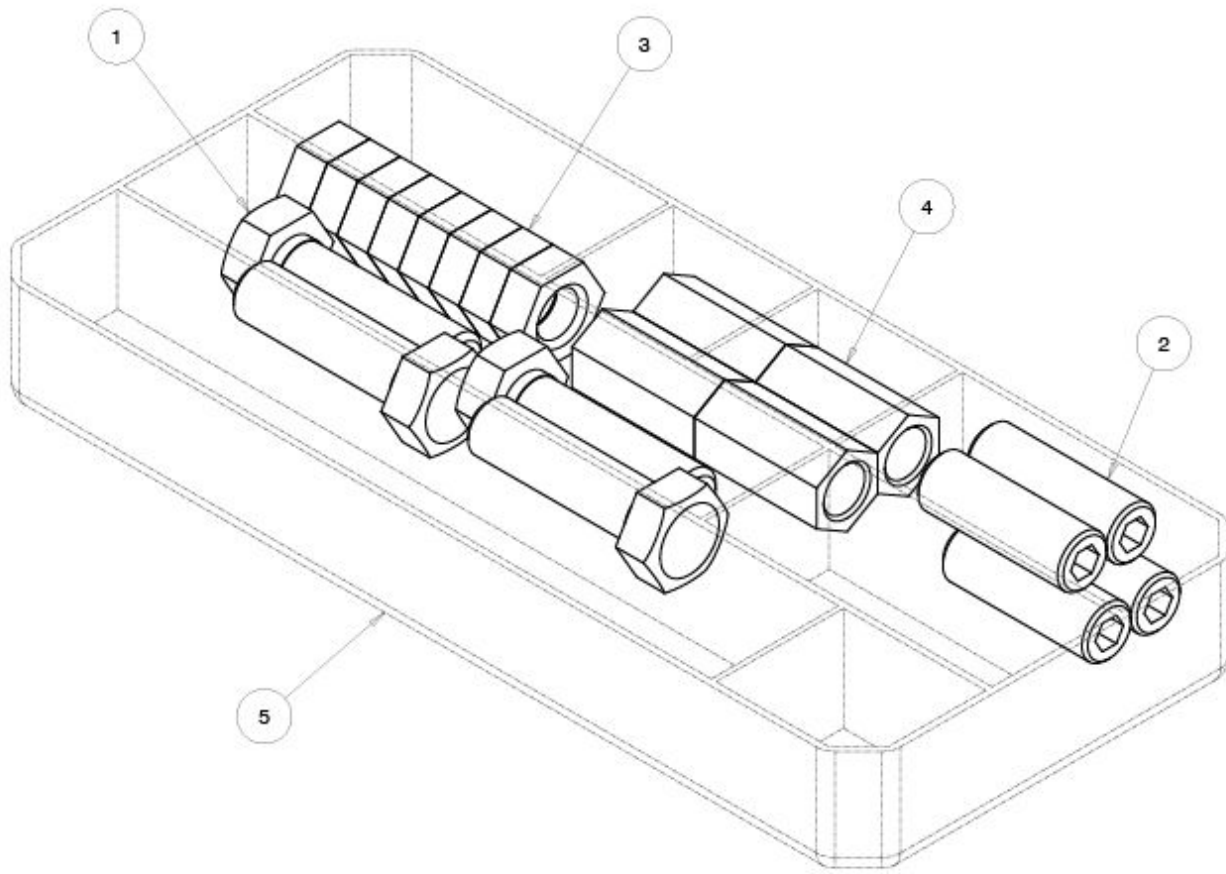

ITEM NO.	QTY.	PART OR IDENTIFYING NO.	DRAWING TITLE OR DESCRIPTION	MANUFACTURER	MFG PART NO.
5	1	599-4020-8V-C	HARDWARE BOX C, STD VOOP	FLAMBEAU	T8003
4	4	503-4006	COUPLING NUT, 1/2-13 X 1.25L, SST	MCMABSTER	90268A088
3	8	90-201-5000-20	JAM NUT, 1/2-13 SST 15-8	MCMABSTER	91847A520
2	4	90-151-5000-1500-20	SET SCREW, CUP POINT 1/2-13 UMC X 1.5L, SST	MCMABSTER	92311A716
1	4	90-104-5000-1750-20	HEX BOLT, 1/2-13 X 1.750 SST 15-8	MCMABSTER	92240A716

UNIVERSAL SONAR MOUNT

ASSEMBLY, VOOP CASE

SIZE	CUSTOMER ORDER/PART NO.	REV
C	---	1
	DRAWING/PART NO.	
	503-102-9910	
SCALE	0.300	SHEET 4 OF 4

ORDER DRAWING/PART NO. ---
 DRAWING/PART NO. 503-102-9910
 REV 1
 SHEET 4 OF 4

4

3

2

1

D

D

C

B

A

A