

REVISIONS				
ZONE	REV	DESCRIPTION	DATE	APPROVED
--	1	INITIAL RELEASE	02016-MAY-25	--
	2	ADDED 1/2-13 FLAT HEAD SCREWS	02017-JUN-06	

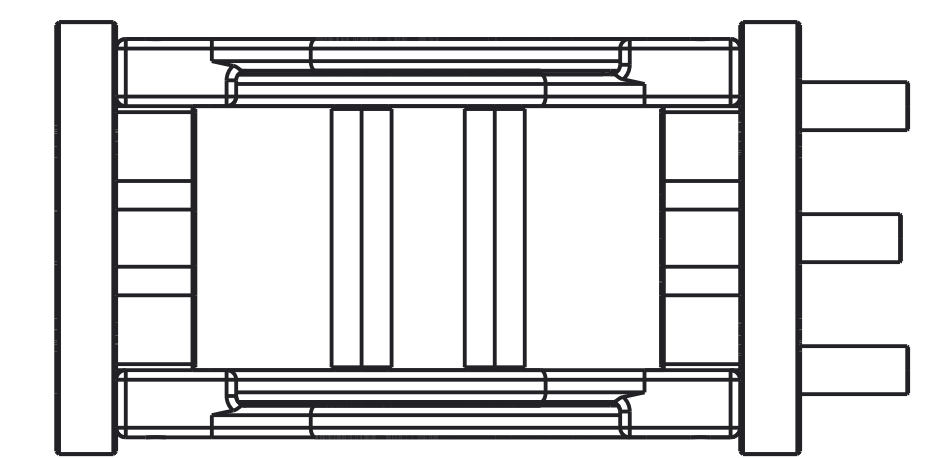
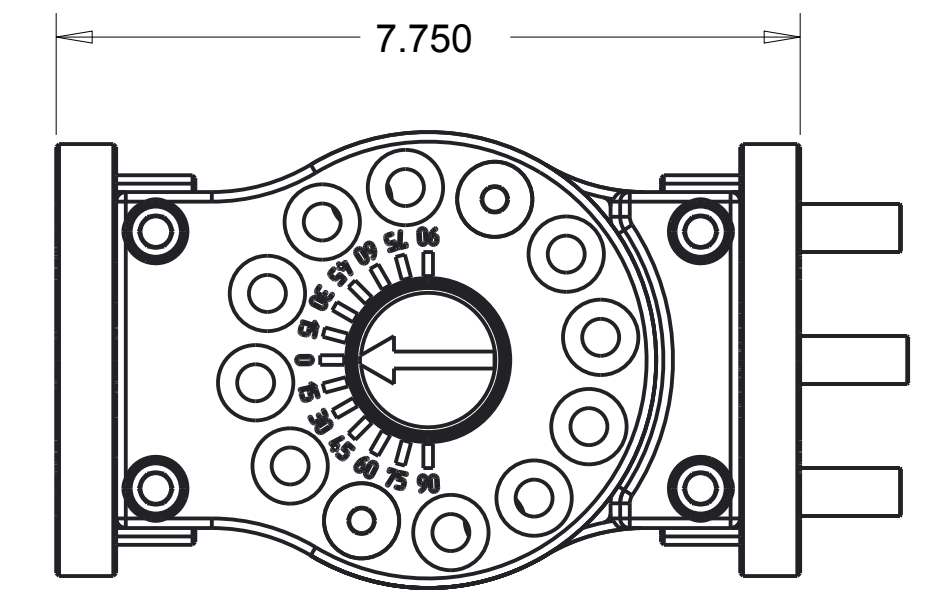
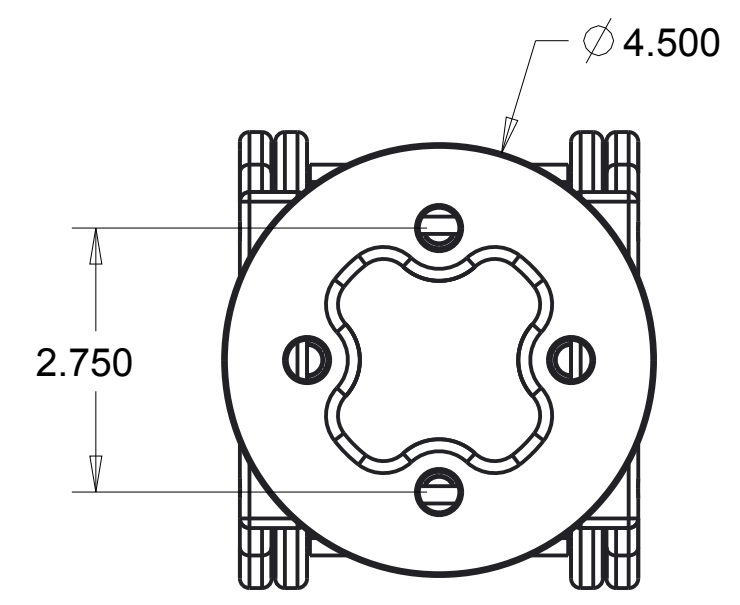
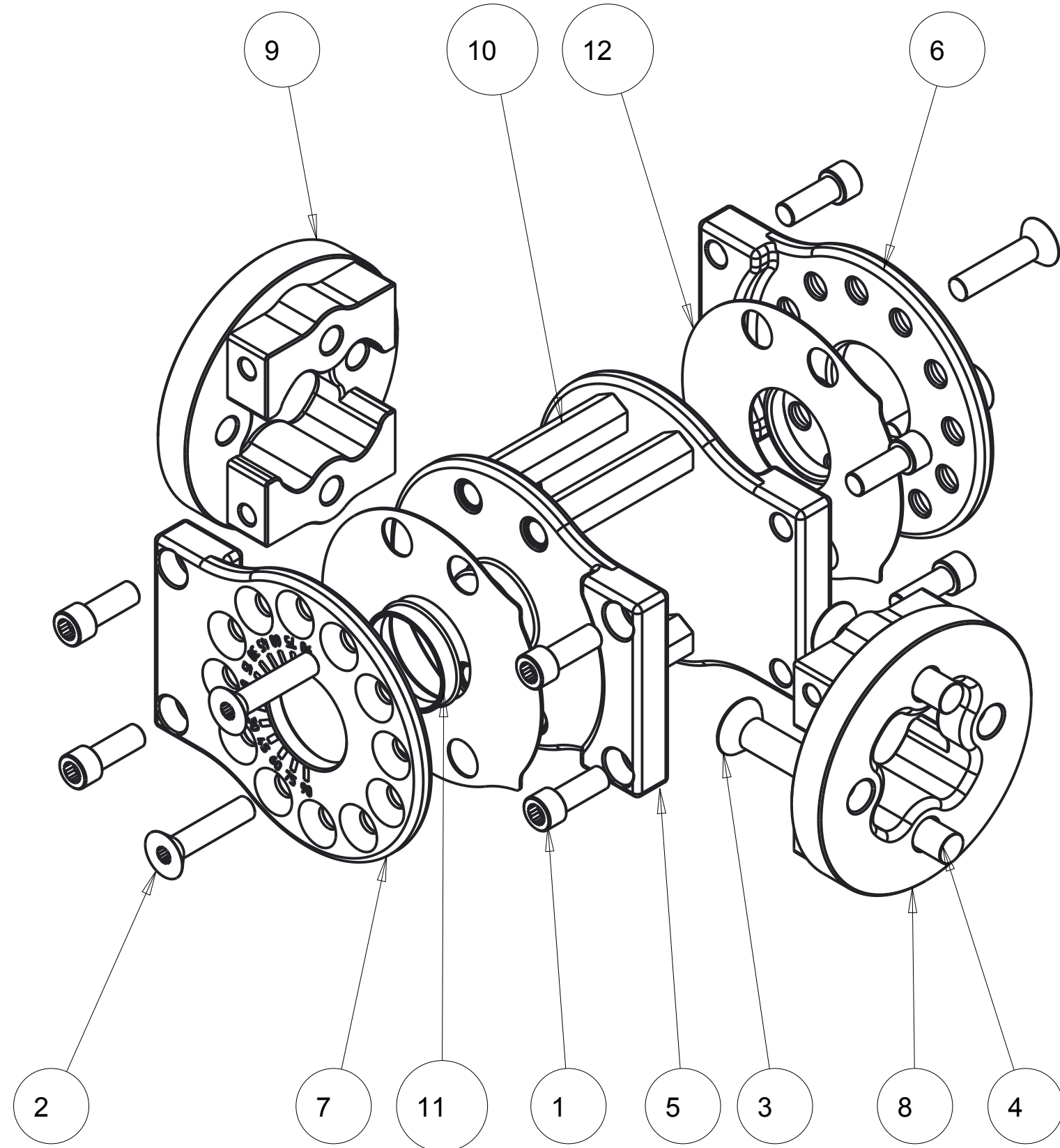

ITEM NO.	QTY REQD.	PART NO.	DRAWING TITLE OR DESCRIPTION	MANUFACTURER	MFG PART NO.
12	2	515-102-1005	KNUCKLE, THRUST SHEET, USM	FAB	---
11	2	515-102-1004	PIVOT BUSHING, COMPACT KNUCKLE	FAB	---
10	4	515-102-1003	HEX SPACER, COMPACT KNUCKLE	FAB	---
9	1	515-102-1002-02	SONAR MOUNT PLATE, COMPACT KNUCKLE	FAB	---
8	1	515-102-1002-01	POLE MOUNT PLATE, COMPACT KNUCKLE	FAB	---
7	1	515-102-1001-03	INDEX PLATE-03, COMPACT KNUCKLE	FAB	---
6	1	515-102-1001-02	INDEX PLATE-02, COMPACT KNUCKLE	FAB	---
5	2	515-102-1001-01	FIXED PLATE, COMPACT KNUCKLE	FAB	---
4	2	90-110-500C-2500-20	SCREW, 1/2-13 UNC X 2.5 FHC 18-8	MCMMASTER	92210A722
3	2	90-110-500C-1750-20	SCREW, 1/2-13 UNC X 1.75 FHC 18-8	MCMMASTER	92240A718
2	4	90-110-375C-1750-20	SCREW, 3/8-16 X 1.75 FHC 18-8	MCMMASTER	92210A630
1	8	90-100-375C-1000-20	SCREW, 3/8-16 X 1.00 SHC 18-8	MCMMASTER	92196A624

UNLESS OTHERWISE SPECIFIED DIMENSIONS ARE IN INCHES. TOLERANCES ARE: .X +/- 0.1 .XX +/- 0.01 .XXX +/- 0.001 ANGLES +/- 0.5	PRO/E REPORTED PARAMETERS	DESIGNER G STAPLES	
	PRO/E MATERIAL	ENGINEER G STAPLES	02016-MAY-25
	PRO/E MASS	DRAFTER G STAPLES	02016-MAY-25
	PRO/E VOLUME	CHECKED ---	02016-MAY-DD
INTERPRET DIMENSIONS PER ASME Y14.5M 1994 (R2004)	PRO/E DRAWING FILE NAME: 515-102-9001	DO NOT SCALE DRAWING	

UNIVERSAL SONAR MOUNT		
ASSY, TILT ADAPTOR, COMPACT		
SIZE	CUSTOMER DRAWING/PART NO.	REV
C	DRAWING/PART NO.	2
	515-102-9001	
SCALE	SHEET 3 OF	
0.500		

CUSTOMER DRAWING/PART NO.

DRAWING/PART NO.

515-102-9001

REV 2 SHT 1

A

4

3

2

1

REVISIONS  
SEE SHEET 1

90 DEG	3.88	3.88
75 DEG	2.87	3.74
60 DEG	1.94	3.36
45 DEG	1.13	2.74
30 DEG	.52	1.94
15 DEG	.13	1.00
0 DEG	0	0
POSITION	Z OFFSET (INCHES)	X OFFSET (INCHES)
OFFSET TABLE		

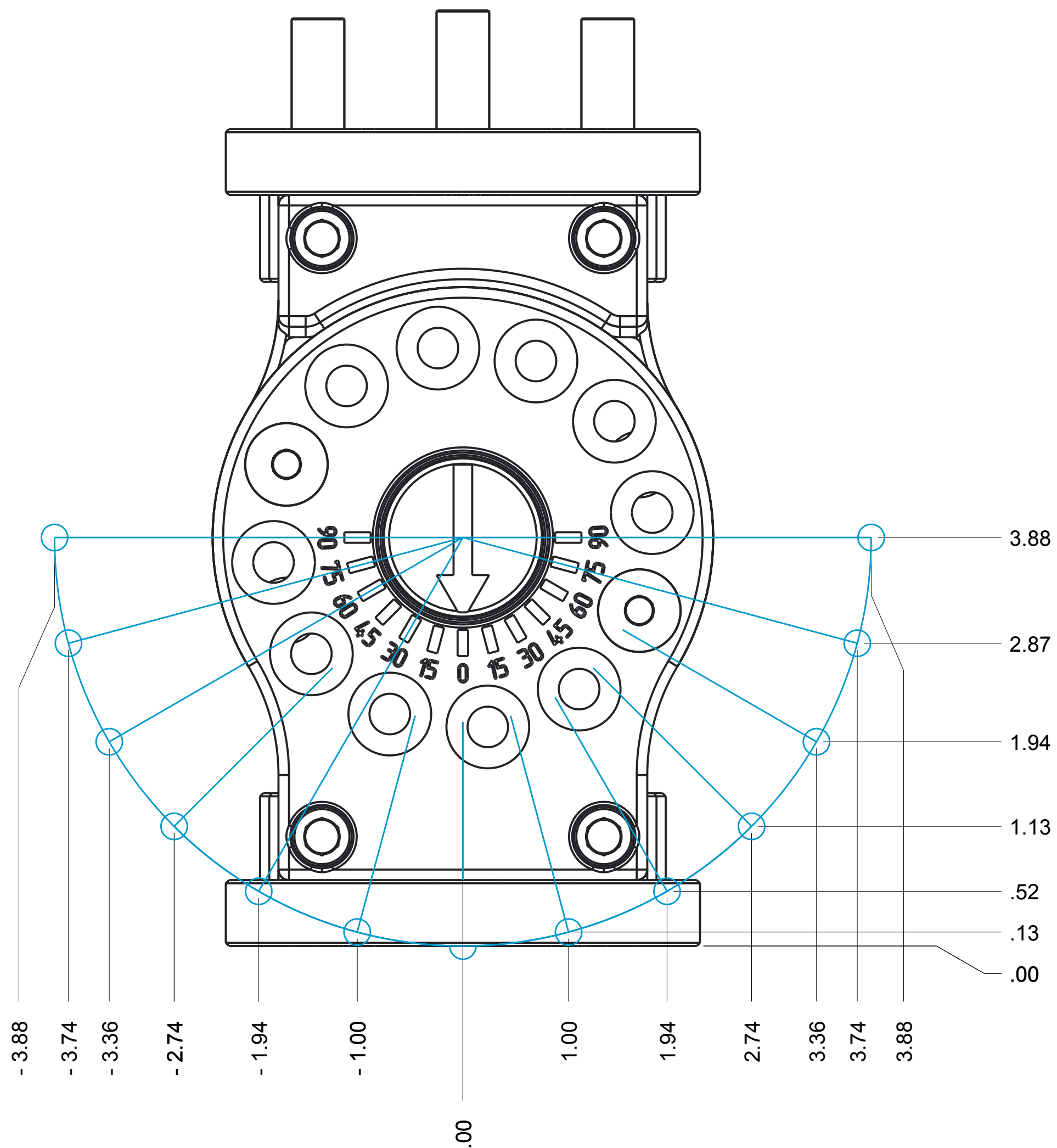

UNIVERSAL SONAR MOUNT		
ASSY, TILT ADAPTOR, COMPACT		
SIZE	CUSTOMER DRAWING/PART NO.	REV
<b>C</b>	---	2
	DRAWING/PART NO.	
	515-102-9001	
SCALE	0.500	SHEET 3 OF

CUSTOMER DRAWING/PART NO. ---  
DRAWING/PART NO. 515-102-9001  
REV. 2  
SHT. 2

4

3

2

1

D

D

C

B

A

A

4

3

2

1

REVISIONS  
SEE SHEET 1

D

D

C

CUSTOMER DRAWING/PART NO. ---

DRAWING/PART NO.

515-102-9001

B

REV

2

SHT

3

A

A

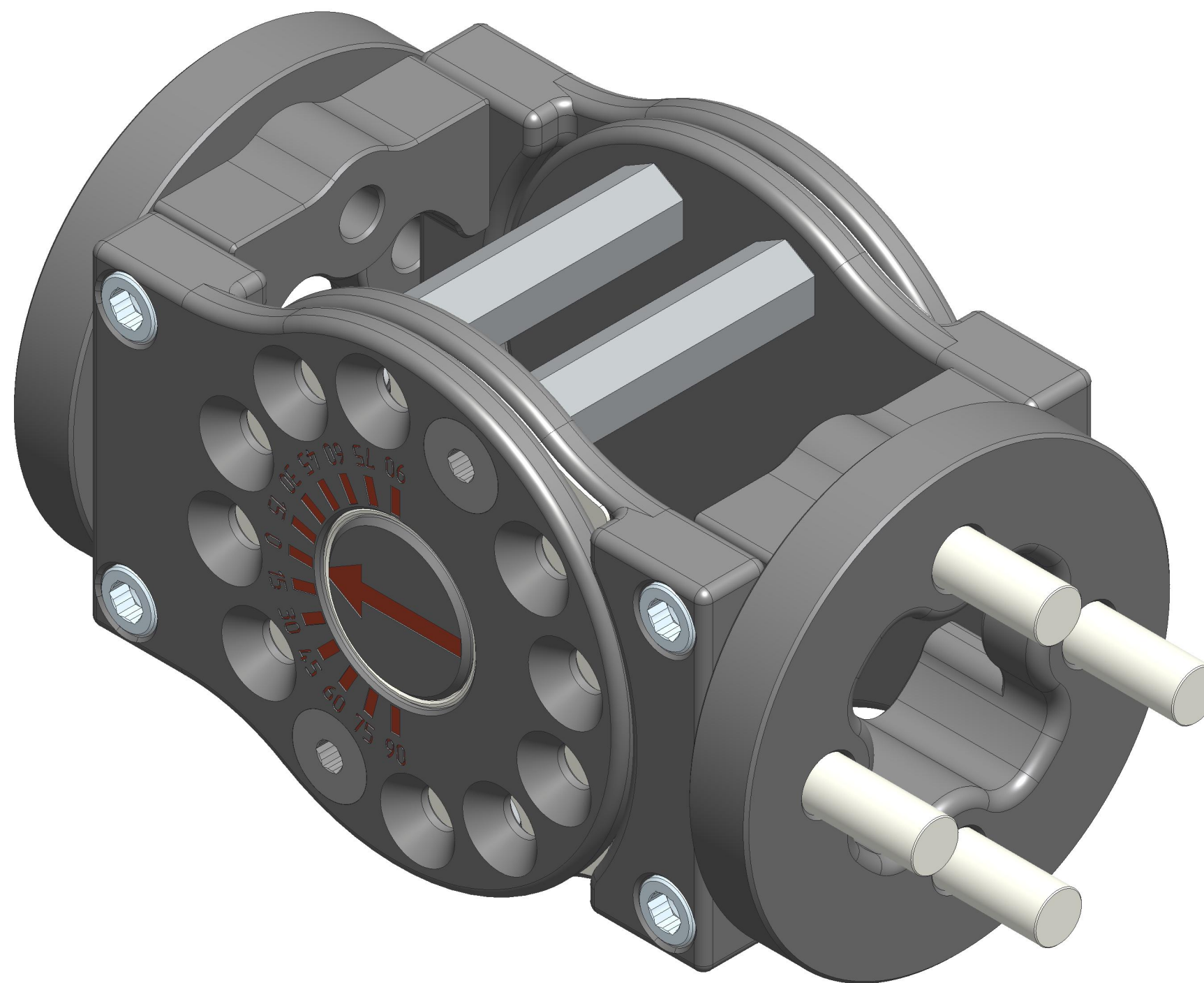

UNIVERSAL SONAR MOUNT

ASSY, TILT ADAPTOR, COMPACT

SIZE	CUSTOMER DRAWING/PART NO.	REV
<b>C</b>	---	2
	DRAWING/PART NO. 515-102-9001	

SCALE 1.000 SHEET 3 OF

4

3

2

1