

USERS GUIDE

K5242 LCD



CONTENT

Preface	1 -
1. Appearance and Dimensions	2 -
1.1 Material and Color	2 -
2. Function and Button Definition	3 -
2.1 Function description	3 -
2.2 Normal Display Content	3 -
2.3 Button definition	3 -
3. Note for Users	4 -
4. Installation Instruction	4 -
5. User Settings	4 -
5.1 On / Off	4 -
5.2 User interface	5 -
5.3 Normal display interface	5 -
5.4 Data statistics interface	5 -
5.5 Walk Assist Mode (Cruise Mode)	6 -
5.6 Headlight On/Off	6 -
5.7 PAS Level Selection	7 -
5.8 Battery Indicator	7 -
5.9 Output Power Indicator	7 -
5.10 Error Code	8 -
6. User Settings	8 -
6.1 Wheel Size Setting	9 -
6.2 Speed Limit Setting	9 -
6.3 Backlight Brightness Setting	10 -
6.4 Display Unit Setting	10 -
6.5 Auto Off Time Setting	11 -
6.6 Battery Display ModeSetting	11 -

6.7 About Interface	12 -
7. Advanced Settings	12 -
7.1 Pas Range Setting	13 -
7.2 Speed Sensor Setting	13 -
7.3 Zero Start Setting	14 -
7.4 PAS Power Sensitivity Setting	14 -
7.5 Start Strength Setting	15 -
7.6 Pas Magnetic Number Setting	15 -
7.7 Current Limit Setting	16 -
7.8 Factory Data Reset	16 -
7.9 Speed Duty Setting (PWM)	17 -
7.10 Driver Mode Setting	17 -
8. Preparation Before Startup	18 -
9. FAQ	18 -
10. Quality Assurance and Warranty Scope	18 -
11. Version	19 -
Appendix 1: Error Code Definition	20 -

Preface

Dear user, to ensure better performance of your e-bike, please read through the K5242 product introduction carefully before using. We will use the most concise words to inform you of all the details (including the hardware installation, setting and normal operation use of the display) when using our display. Meanwhile, the introduction will also help you to solve possible confusion and barriers.

1. Appearance and Dimensions

1.1 Material and Color

K5242 products are made of black and white PC. Under the temperature of -20 to 60°C , the shell material can ensure normal usage and good mechanical performance.

Dimension (unit: mm)

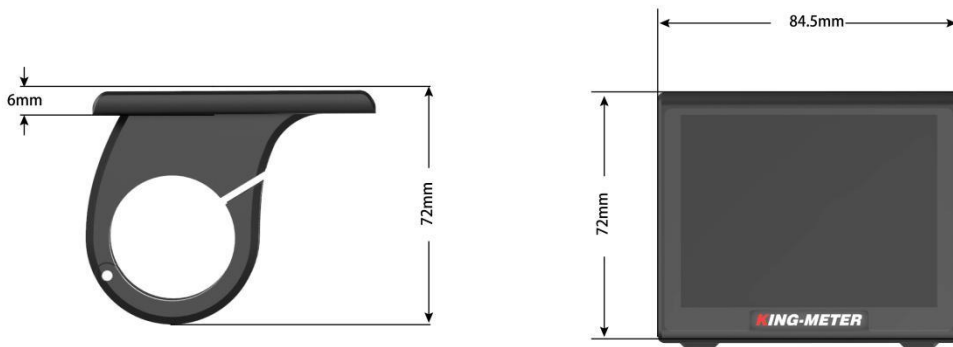

K5242 is equipped with special button. N3 button can be installed on the left side of the handlebar or on the right side of the handlebar. N3 button is connected with the bottom lead of k5242 display. Its dimension is as follows:

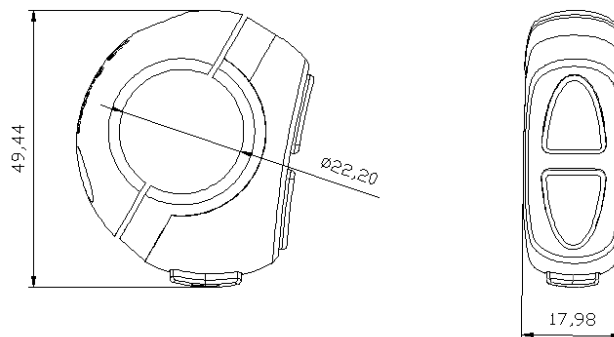

2. Function and Button Definition

2.1 Function description

K5242 provides you with a variety of function modes, to meet your riding needs.

Its functions are as follows:

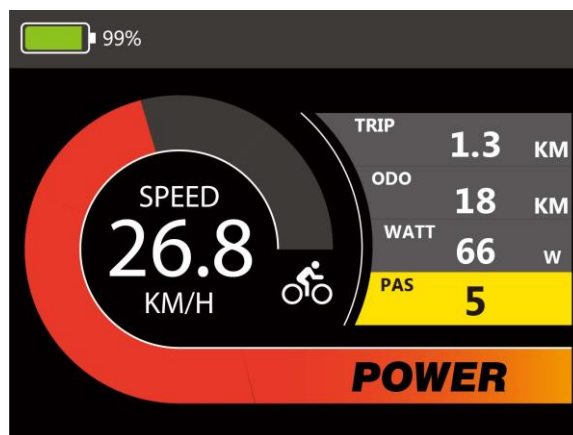

- ◆ Battery power indication
- ◆ Motor power indication
- ◆ Speed indication
- ◆ Distance (including single trip distance and ODO display)
- ◆ Single riding time indication
- ◆ Walk assist indication
- ◆ Cruise Mode
- ◆ Backlight setting
- ◆ Error code indication
- ◆ Various setting parameters

2.2 Normal Display Content



K5242 Normal Display Interface

2.3 Button definition

There are 3 buttons on K5242, In the following introduction,  is named as "MODE".  is named as "UP" and  is named as "DOWN".

3. Note for Users

Be care of the safety use. Don't attempt to release the connector when battery is on power.



Try to avoid hitting.



Don't split the waterproof sticker to avoid affecting the waterproof performance.



Don't modify system parameters to avoid parameters disorder.



Make the display repaired when error code appears.

4. Installation Instruction

When the e-bike is powered off, you can insert the connector of display and the corresponding connector of controller to complete the installation, and adjust the display to a suitable angle.

5. User Settings

5.1 On / Off

Long press "MODE" button then the display will work normally, and the controller will power on at the same time.

With the display on, long press "MODE" button, the display will shut down, the display will leave off battery, the leakage current of display on is less than 1 μ A. The startup logo is shown as follow:



If the e-bike is not used for more than 10 minutes, the display will automatically shut down.

5.2 User interface

There are two display interfaces, including normal display interface and data statistics interface. Long press “UP” + “MODE” button to switch from normal display interface to data statistics interface; long press “MODE” button to switch back from data statistics interface to normal display interface.

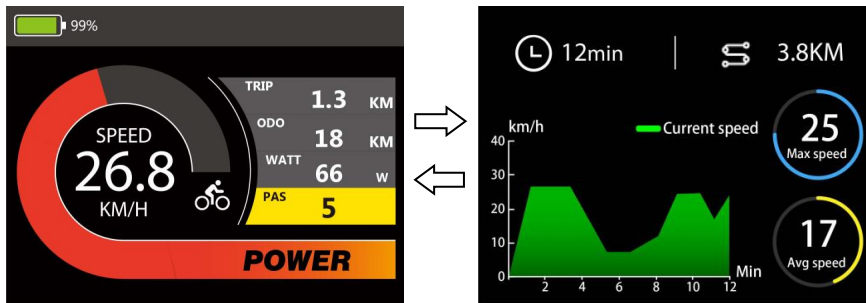

Normal display interface

Data statistics interface

5.3 Normal display interface

The normal interface can be displayed when the display starts up normally. The interface can display real-time battery power, real-time speed (SPEED), single trip distance (TRIP), odometer (ODO), Motor Power output (WATT) and PAS level (PAS) of the E-bike.

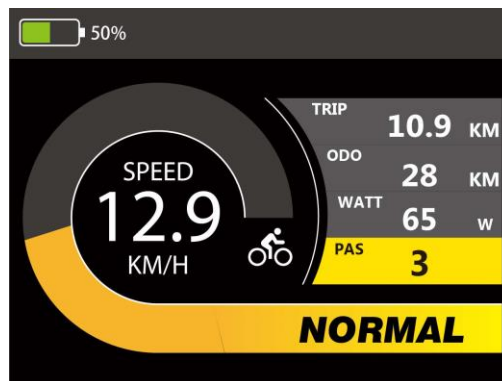

Normal display interface

5.4 Data statistics interface

When the speed is 0, long press “UP” + “MODE” button to switch from the normal display interface to the data statistics interface.

The data statistics interface is used to calculate and display the data of single ride of E-bike. It includes riding time, riding distance, max speed, Avg Speed and linear statistical chart of single riding speed.

Long press “MODE” button or when E-bike has speed, the data statistics interface will switch to the

normal display interface automatically.

Note: the maximum statistical time range of linear statistical chart is three hours, and the timing will re-start again after three hours.



Data statistics interface

5.5 Walk Assist Mode (Cruise Mode)

When there is no speed, press and hold “**DOWN**” button for 3 seconds to enter the Walk assist mode. The E-bike will travel at a constant speed of 6km/h. Press and hold “**DOWN**” button again for 3 seconds or squeeze the brake lever to exit the walk assist mode.

When the bike is riding with a speed, press and hold “**DOWN**” button for 3 seconds to enter the Cruise mode. The E-bike continues to drive at current speed, press and hold “**DOWN**” button again for 3 seconds or squeeze the brake lever .to exit the cruise mode.

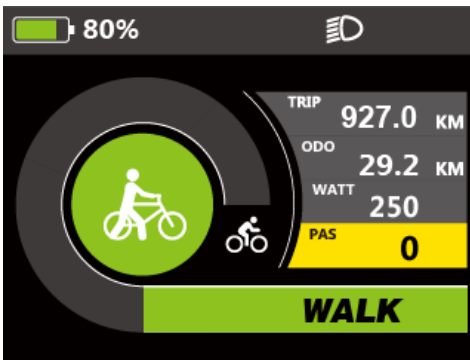

Walk assist mode interface

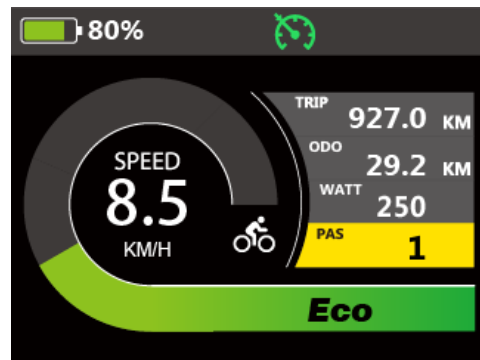

Cruise mode interface



Walk Assist function can only be used as pushing the e-bike by hands. Please don't use this function when riding.

5.6 Headlight On/Off

Long press the “**UP**” button, the backlight will be turned on, and the controller will be informed to turn on the headlight. Long press the “**UP**” button for 2 seconds again to turn off the backlight and turn off

the headlight.

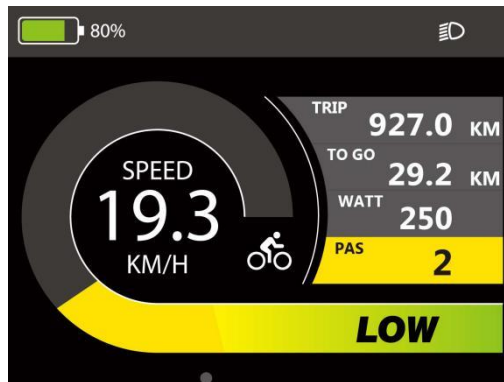

Headlight indicator

5.7 PAS Level Selection

Short press the "UP" or "DOWN" button to switch the PAS level, the motor output power will be changed accordingly by the PAS level of E-bike. The default range of PAS level is 0-5 levels. Level 1 is the lowest output level, and the level 5 is the highest output power level of the motor.

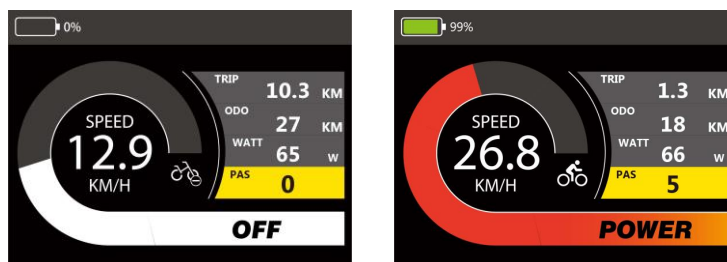

PAS level indicator

5.8 Battery Indicator

The battery power is shown as a percentage bar. When the battery is fully charged, the power bar shows 100%



Battery indicator

5.9 Output Power Indicator

The display can show the current output power of the motor. The indicator is shown in the figure below.

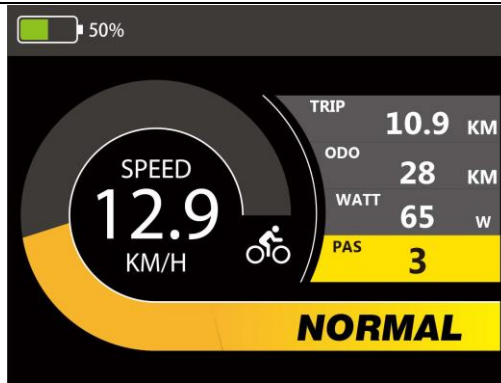

Output Power Indicator

5.10 Error Code

When the e-bike electronic control system fails, the display will automatically indicate the error code. For the definition of detailed error codes, see appendix 1.

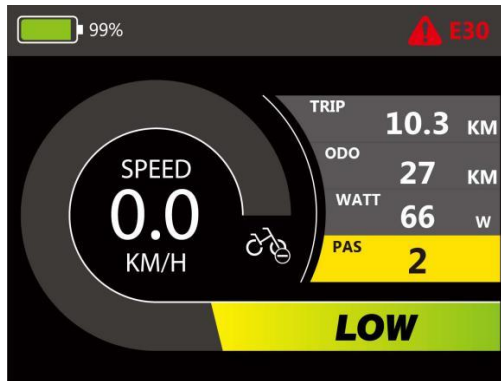

Error Code indicator



The fault can only be exited when the fault is eliminated, and the E-bike cannot continue to drive after a fault occurs.

6. User Settings

When there is no speed in the power on state, press and hold the “UP” and “DOWN” button at the same time for 2 seconds, and the display will enter the setting interface. Press “UP” or “DOWN” button to select display settings.

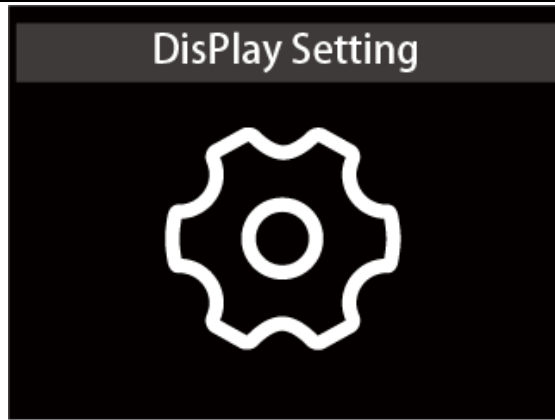

Setting list interface

6.1 Wheel Size Setting

Short press “**MODE**” button to enter the setting option. The settable values are: 16, 18, 20, 22, 24, 26, 700C, 27.5, 28 and 29 inch. Select the corresponding wheel diameter of the E-bike through “**UP**” and “**DOWN**” button to ensure the accuracy of the speed display and mileage display. Long press “**MODE**” button to return to the setting list interface.

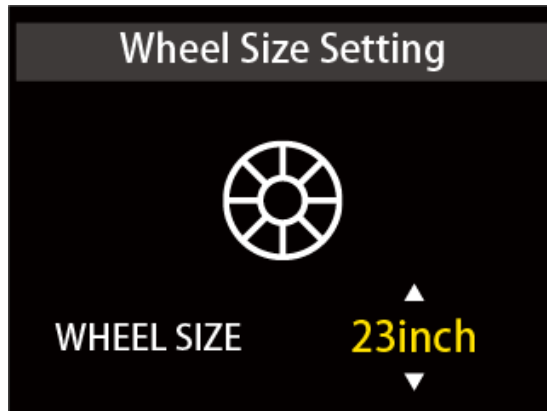

Wheel size setting interface

6.2 Speed Limit Setting

Short press “**MODE**” button to enter the setting option. The optional range of the maximum speed setting is 20Km/h to 50Km/h and 99Km. 99Km is unlimited. It can be set by “**UP**” and “**DOWN**” button. Long press “**MODE**” button to return to the setting list interface.

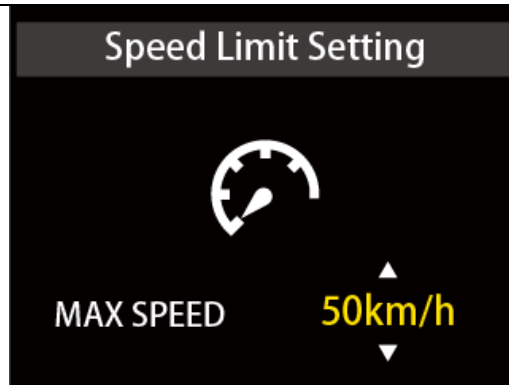

Speed limit setting interface

6.3 Backlight Brightness Setting

Short press “**MODE**” button to enter the setting option. The setting options: 1, 2 and 3 indicates the backlight brightness, 1 is the darkest, 2 is standard brightness, 3 is the brightest. The default value is 3. Long press “**MODE**” button to return to the setting list interface.



Backlight brightness setting interface

6.4 Display Unit Setting

Short press “**MODE**” button to enter the setting option. The setting parameters are Km/h and Mile/h. The default Km/h unit is metric. Km/h or Mile/h can be selected by pressing “**UP**” and “**DOWN**” button. Km/h means the unit is metric system, and Mile/h means the unit is Imperial system. Long press “**MODE**” button to return to the setting list interface.

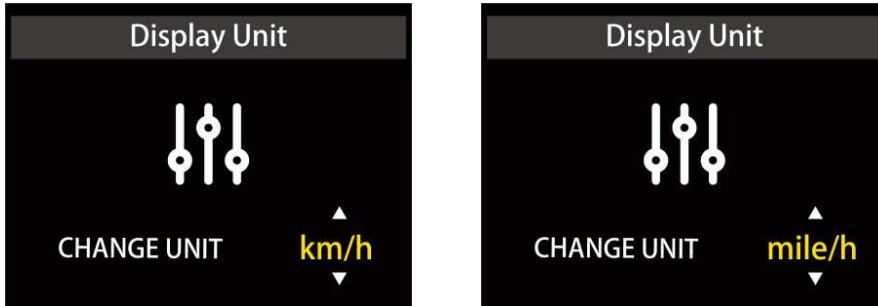

Display unit setting interface

6.5 Auto Off Time Setting

Short press “**MODE**” button to enter the setting option. Press the “**UP**” and “**DOWN**” button to adjust the auto off time. The optional range is from 5min to 60min, Default setting is 10min. long press “**MODE**” button to return to the setting list interface.

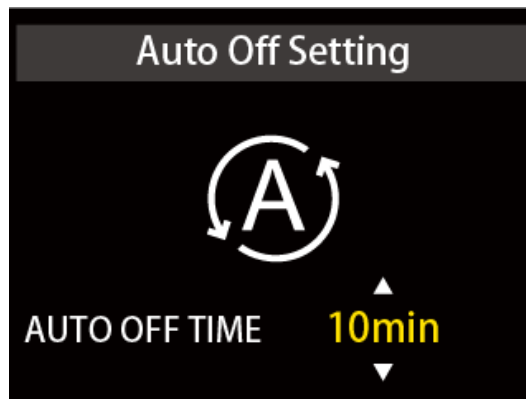

Auto Off Time setting interface

6.6 Battery Display Mode Setting

Short press “**MODE**” button to enter the setting option. Setting options can select between percentage and volt display, It can be set by pressing “**UP**” and “**DOWN**” button. Long press “**MODE**” button to return to the setting list interface.

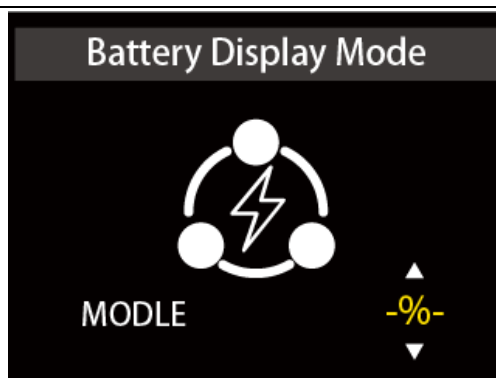

Battery Display Mode setting interface

6.7 About Interface

Short press “**MODE**” button to enter the “About” interface, this interface shows manufacturer’s name, software and hardware version number and other information, which is usable for later display maintenance.



7. Advanced Settings

When there is no speed in the power on state, press and hold the “**UP**” and “**DOWN**” button at the same time for 2 seconds, and the display will enter the setting interface. Press “**UP**” or “**DOWN**” button to select the Advanced display settings.

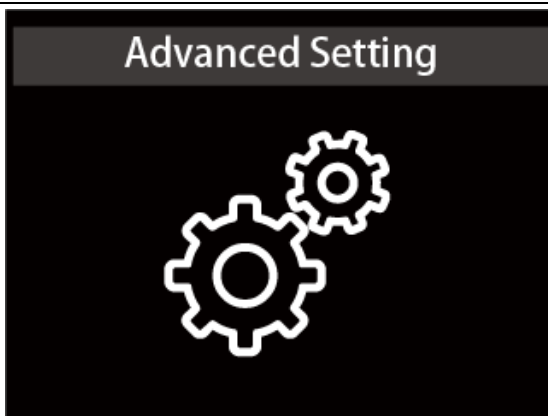

Advanced Display Setting

7.1 Pas Range Setting

Short press “**MODE**” button to enter the setting interface, there are 3 modes in the PAS level selection: 0-3 , 0-5, 0-9,. Switch by pressing “**UP**” or “**DOWN**” button, short press “**MODE**” button to confirm, Long press “**MODE**” button to return to the setting list interface.

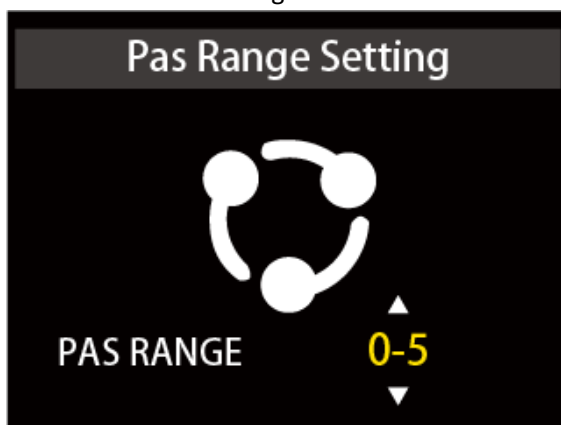

PAS Range Setting

7.2 Speed Sensor Setting

Short press “**MODE**” button to enter the setting interface. the setting range is from 1 to 6. It should be set according to the number of magnets installed on the wheels of the E-bike. Press “**UP/DOWN**” button to select the quantity of magnet. Long press “**MODE**” button to confirm and return to the setting selection interface.

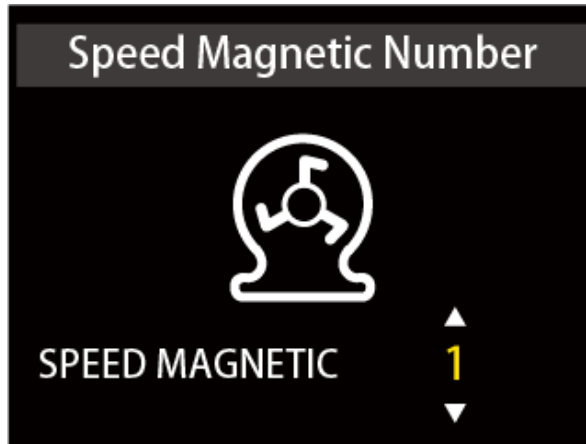

Speed Sensor Magnetic setting interface

7.3 Zero Start Setting

Short press “**MODE**” button to enter the setting interface. Press “**UP/DOWN**” to select Yes or No, Yes means motor can be started at 0 speed with throttle, No means the throttle function can be used only at an initial speed. Long press “**MODE**” button to confirm and return to the setting selection interface.



Zero Start setting interface

7.4 PAS Power Sensitivity Setting

Short press “**MODE**” button to enter the setting interface. The setting range is 3 to 24. 3 is the highest sensitivity, 24 is the lowest. Press “**UP/DOWN**” button to select sensitivity value, Default setting is 3. Long press “**MODE**” button to confirm and return to the setting selection interface.

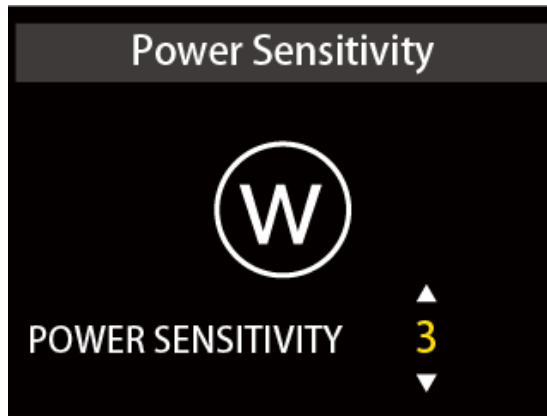

PAS Power Sensitivity setting interface

7.5 Start Strength Setting

Short press “**MODE**” button to enter the setting interface. The setting range is 1 to 5. 5 is the highest start strength, 1 is the lowest, Press “**UP/DOWN**” button to select start strength value, Default setting is 3. Long press “**MODE**” button to confirm and return to the setting selection interface.



Start Strength setting interface

7.6 Pas Magnetic Number Setting

Short press “**MODE**” button to enter the setting interface. The setting range is 5/8/12. It should be set according to the number of magnets disk that installed on the E-bike. Press “**UP/DOWN**” button to select value, Default setting is 12. Long press “**MODE**” button to confirm and return to the setting selection interface.

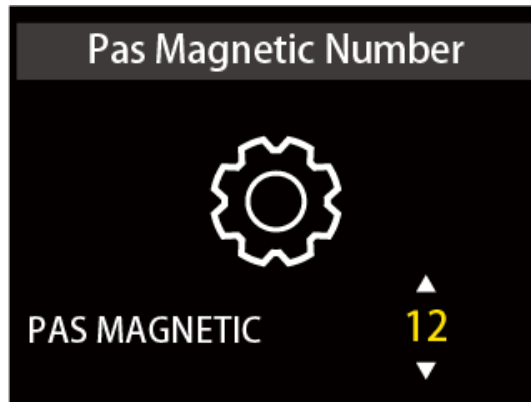

PAS Magnetic Number setting interface

7.7 Current Limit Setting

Short press “**MODE**” button to enter the setting option. The current limit can be set in the range of 1.0-22.0A. Press “**UP/DOWN**” button to change the maximum current value of the controller. Default setting is 22A. Long press “**MODE**” button to confirm and return to the setting selection interface.

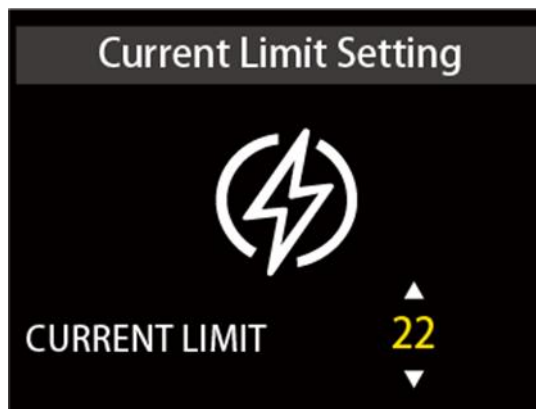

Current Limit setting interface

7.8 Factory Data Reset

Short press “**MODE**” button to enter the setting interface. Press “**UP/DOWN**” to select Yes or No, Yes means to restore all the settings to the default settings, No means not restore all the settings. Long press “**MODE**” button to confirm and return to the setting selection interface.

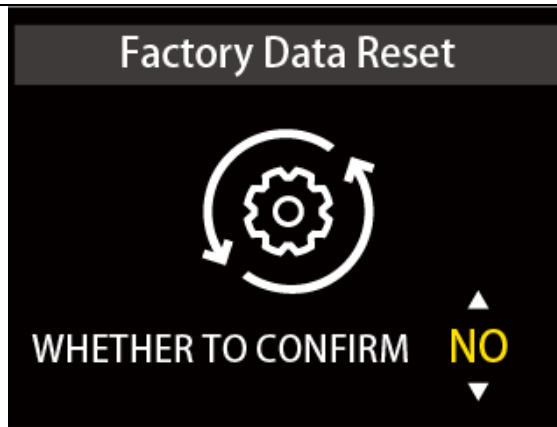

Factory Data Reset interface

7.9 Speed Duty Setting (PWM)

Short press “**MODE**” button to enter the setting option. The setting options can be set in the range of 0%-100%. Press “**UP/DOWN**” button to change the value of the Speed duty percentage. Long press “**MODE**” button to confirm and return to the setting selection interface.

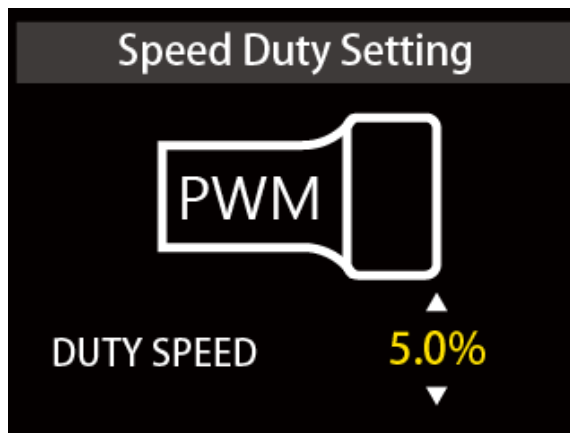

Speed Duty Setting interface

7.10 Driver Mode Setting

Short press “**MODE**” button to enter the setting interface. The setting options are 0, 1 and 2. Press “**UP/DOWN**” button to select 0, 1 and 2 to adjust the three riding assist modes, 0 indicates only PAS assist mode, 1 indicates only throttle mode, 2 indicates coexistence of two assisted mode. Press “**UP/DOWN**” button to select value. Default setting is 2. Long press “**MODE**” button to confirm and return to the setting selection interface.

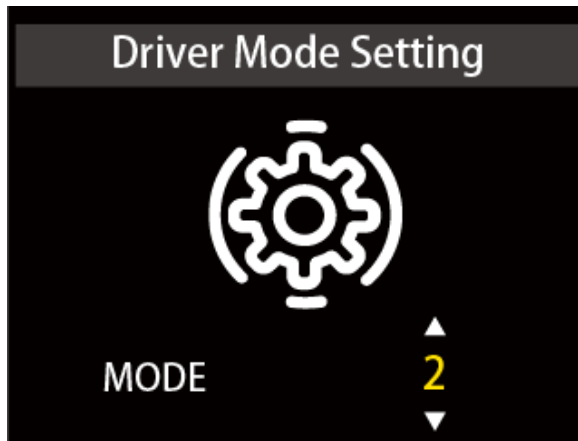

Driver Mode Setting interface

8. Preparation Before Startup

Please read the instruction carefully before using the display.

9. FAQ

Q: Why can't turn on the display?

A: Please check whether the battery is turned on or the leakage lead wire is broken

Q: How to deal with the error code display?

A: Contact the e-bike maintenance station in time.

10. Quality Assurance and Warranty Scope

I, Warranty Information:

1, King-Meter will be responsible for all faults arising during normal operation that are caused by a quality defect.

2, The warranty time is 24 months from the day the display leaves the factory.

II, The following are not covered by warranty:

1, Shell opened.

2, Connector damaged.

3, After display out of factory, the shell is scratched or damaged.

4, Lead wire of display scratch or break.

5, The fault or damage is caused by the force majeure (such as fire, earthquake, etc.) or natural disasters (such as lighting, flooding, etc.)

6, Product exceeded warranty period.

11. Version

The instruction manual of this display is the operation manual of the general software version (version 1.0) of Tianjin King-Meter Technology Co., Ltd. The version of the display software used on some vehicles may be slightly different from this manual, and the actual version used shall prevail.

Appendix 1: Error Code Definition

Error Code	Definition
0x04	Throttle abnormal
0x06	Under voltage protection
0x08	Motor Hall abnormal
0x09	Motor phase cable failure
0x10	Controller high temperature protection
0x11	Motor high temperature protection
0x12	Current sensor failure
0x13	Battery temperature failure
0x14	Motor temperature sensor failure
0x15	Controller temperature sensor failure
0x21	Speed sensor failure
0x23	Headlight fault
0x24	headlight sensor failure
0x25	Torque sensor torque signal failure
0x26	Torque sensor speed failure
0x30	Communication failure

