



Medi Lift Essential
Electrical Muscle Stimulation (EMS) Mask
EPM-18-G
USER MANUAL

Please read all instructions carefully for safe and proper use.

Use only as directed

—improper use may cause injury or malfunction.

Immediately discontinue use if any malfunction or unusual reaction to treatment occurs.

QUICK START

1

CHARGING THE LEFT AND RIGHT CONTROLLERS

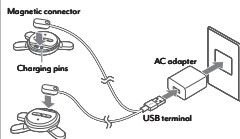

Charging	The light will blink blue.
When charging is complete	The light will go off. Unplug the USB charging cable.
Charging time	Approx. 2 hours (room temperature approx. 25°C (77°F))
Operating time	Approx. 4.5 hours

* Actual charging time and operating time will differ depending upon the remaining power and the charging environment.

Charge the EMS Controllers for 2 hours before your first use. From there, the device will hold the charge for 4.5 hours. Make sure the magnetic charging terminal is attached in the correct direction to start the charge.

2

ATTACH THE TWO CONTROLLERS TO THE SILICONE MASK

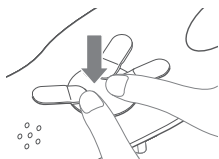

Check the left/right attachment guideline marks and push the controller into the recessed part on the back of the silicone mask. Attach the EMS Controllers to the silicone mask by pushing in gently. Make sure the power is switched off and you don't press any buttons when attaching the controllers.

3

GENEROUSLY WET YOUR CHEEKS



EMS will NOT be delivered to skin unless there is water between the electrodes and your skin.

4

FIT THE SILICON MASK TO YOUR FACE

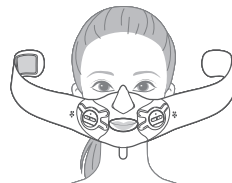

Look for the "L" and "R" engravings for left and right on the back of the mask as your guide and match up the nose and mouth cutouts to fit the mask to your face.

5

PLACE THE ADJUSTABLE BAND IN A POSITION AS SHOWN

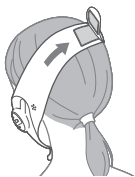

Pull the band over the top of your head to secure the mask in place.

If the silicone mask is a lack of length for you, attach the extender belt to the silicone mask.

6

TURN ON EACH OF THE CONTROLLERS

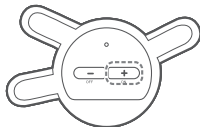

Press the +/ON button for 2 seconds on both controllers at the same time. The controllers will beep and show a Pink color light.

- The EMS level (intensity) is set to Level 0 (no EMS output) by default when the device is turned on.

7

SELECT YOUR MOST COMFORTABLE LEVEL OF EMS INTENSITY

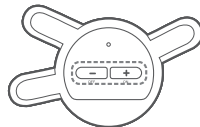

You can change the intensity of the EMS by pressing +/ON or -/OFF buttons. There are 5 levels, and the controller will beep every time a button is pressed.

There will be a longer beep if you are at the minimum level 0 (no EMS) or maximum level 5. Start with level 1 for first-time treatment and only move onto higher intensity levels when it feels comfortable.

8

TURN OFF THE DEVICE

The device will automatically turn off after approximately 10 minutes. To stop the treatment during use, press the -/OFF button on both controllers for 2 seconds.

Table of Contents

Intended Use ————— p4

Contraindications ————— p4

Possible Side Effects ————— p5

Intended User Population ————— p6

WARNINGS ————— p6

Precautions ————— p7

About This Device ————— p7

Getting To Know Your Device ————— p8

How To Use ————— p12

Storing the Device ————— p21

Maintenance and Disposal ————— p22

Troubleshooting ————— p23

Specifications ————— p27

Labeling and Signs ————— p29

Intended Use

This device is intended for facial stimulation and indicated for over-the-counter cosmetic use.

Contraindications

Do not use this device if:

- You have an implanted pacemaker or other electronic implanted devices.
- You have an arrhythmia or any other known heart disorder.
- You have epilepsy, multiple sclerosis, phlebitis, varicose veins, cancer, or a tendency to hemorrhage.
- You have inflamed tissue as a result of disease, injury or surgery.
- You are under 21 years old.
- You are pregnant.
- You have known sensitivity to Electrical Muscle Stimulation (EMS).
- You have excessive sunburn on the face or neck.

If you have any serious illness or injury not mentioned above, any medical supervision, or questions about any other medical condition such as facial surgery or medication that may affect the treatment, please consult your doctor or physician before using the Medi Lift.

Possible Side Effects

Skin irritation, affected fillings/toothache, and burns beneath the electrodes have been reported when using powered muscle stimulation devices on the face. If you experience such side effects, please discontinue use of the device.

MedWatch is the Food and Drug Administration's (FDA) program for reporting serious reactions, product quality problems, therapeutic inequivalence/failure, and product use errors with human medical products, including drugs, biologic products, medical devices, dietary supplements, infant formula, and cosmetics.

If you think you or someone in your family has experienced a serious reaction to a medical product, you are encouraged to take the reporting form to your doctor. Your health care provider can provide clinical information based on your medical record that can help FDA evaluate your report.

However, we understand that for a variety of reasons, you may not wish to have the form filled out by your health care provider, or your health care provider may choose not to complete the form. Your health care provider is not required to report to the FDA. In these situations, you may complete the Online Reporting Form yourself.

You will receive an acknowledgement from FDA when your report is received. Reports are reviewed by FDA staff. You will be personally contacted only if we need additional information.

Submitting Adverse Event Reports to FDA

Use one of the methods below to submit voluntary adverse event reports to the FDA:

Report Online at www.accessdata.fda.gov/scripts/medwatch/index.cfm?action=reporting.home

Consumer Reporting Form FDA 3500B. Follow the instructions on the form to either fax or mail it in for submission. For help filling out the form, see MedWatchLearn. The form is available at www.fda.gov/downloads/aboutFDA/reportsmanualsforms/forms/ucm349464.pdf

Call FDA at 1-800-FDA-1088 to report by telephone.

Reporting Form FDA 3500 commonly used by health professionals. The form is available at www.fda.gov/downloads/aboutFDA/reportmanualsforms/forms/ucm163919.pdf

Intended User Population

The Medi Lift is intended for persons 22 years of age and older.

Do not use on children.

Keep out of the reach of children.

WARNINGS

This device is not intended for use by persons with reduced physical, sensory or mental capabilities, or lack of experience and knowledge.

Apply the silicone mask with the controllers **ONLY** as instructed in this manual

Only use the provided controllers with the mask.

The long-term effects of electrical muscle stimulation are unknown.

Use the silicone mask with the controllers only on the face.

Do not place the controllers;

Near thorax (it may increase the risk of cardiac fibrillation)

Across the head

Directly on the eye

Covering the mouth

On the front of the neck (especially the carotid sinus)

Across the heart (i.e., One controller on the front of the chest and one on the back)

Over areas of vascular problems (e.g., phlebitis, thrombophlebitis; varicose veins, etc.)

Over inflamed or infected skin or skin eruptions

Over or near cancerous or other skin lesions or wounds.

Over any parts where feeling is limited.

In areas on recent administration of Botox or dermal fillers

Directly over or near metal implants or fillers.

Do not use the Medi Lift while driving, operating machinery, cycling or any activities which involuntary muscle contractions may endanger the user or others.

Do not use the device if you are connected to high frequency surgical device. It may result in burns at the site of the electrodes and possible damage to the controllers.

Do not use the Medi Lift in close proximity to a shortwave or microwave therapy device which may produce instability in the device output.

Do not use this device on injured or otherwise impaired skin or muscles.

Do not use this device for any therapy or rehabilitation or for the treatment, diagnosis, prevention or cure of any medical conditions or diseases.

IMMEDIATELY STOP using the Medi Lift when you experience any skin irritation, hypersensitivity, burns or any adverse reaction, and call your physician.

Precautions

The Medi Lift is intended for use by single person **ONLY**. **DO NOT** share this device with anyone else to avoid contamination risk.

About This Device

The Medi Lift is a home-use, battery-powered facial EMS device. This device delivers low frequency electrical pulses to the face for improving facial muscle tone and firming facial skin. This device has a mask made of silicone rubber which is worn on your the part of your face. Two controllers with electrodes are attached to the mask to delivery electrical pulses to stimulate your facial muscles.

We recommend using the device once a day for 10 minutes. The device automatically turns off 10 minutes after the device is turned on or the intensity level of the EMS is set.

Do not use the controllers without first attaching them to the mask.

■ Getting To Know Your Device

Controllers

● For left side of the cheek

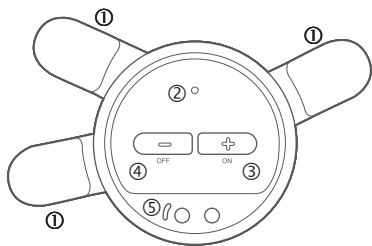

Front

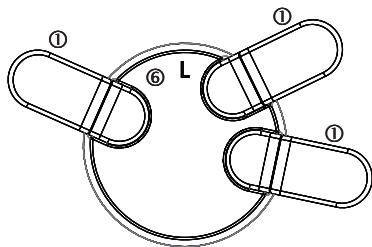

Back

● For right side of the cheek

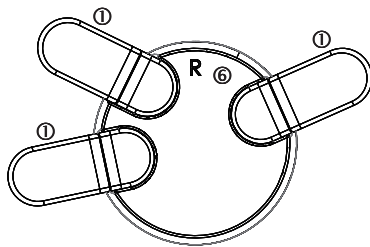
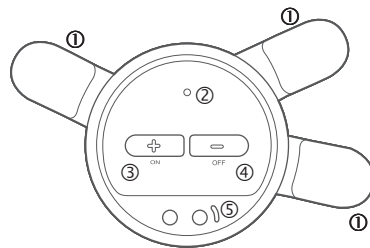

Controllers generate electrical current.

Description of the controller

No	Name	Description
①	Electrode	Delivers electrical current to the face.
②	LED Signals	<ul style="list-style-type: none">● Pink light when the device is turned on. The pink LED is turned off when the device is turned off.● Blinks blue when the device is charging. The blue LED lights for 1 minutes from reaching a full charge.
③	+ / ON button	<ul style="list-style-type: none">● Turns on the device. Press and hold this button for 1 seconds to turn off.● Increases current intensity by pressing this button. The intensity can be set from 0 (no output) to 5.
④	- / OFF button	<ul style="list-style-type: none">● Turns off the device. Press and hold button for 1 second to turn off.● Decreases current intensity by pressing this button. The intensity can be set from 0 (no output) to 5.
⑤	Charging pins	Connects with the USB cable for charging.
⑥	Mark for attaching side	The controller labeled “R” should be attached to the mask on the right cheek side. The controller labeled “L” should be attached to the mask on the left cheek side.

LED Signals

LED Signals	Meaning
Solid Pink	The device is turned ON.
Blinking Blue	The device is charging.
Solid Blue	The device is fully charged. The blue LED lights for 1 minutes from reaching a full charge.

Silicone mask

Front

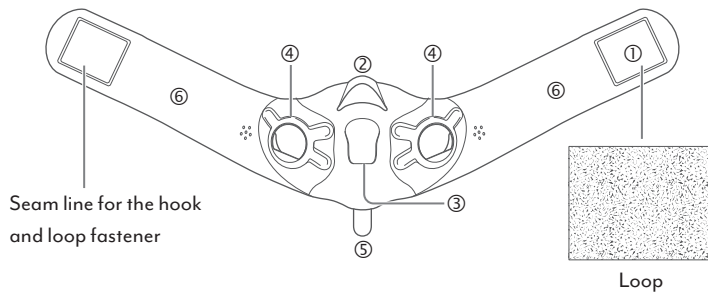

Back

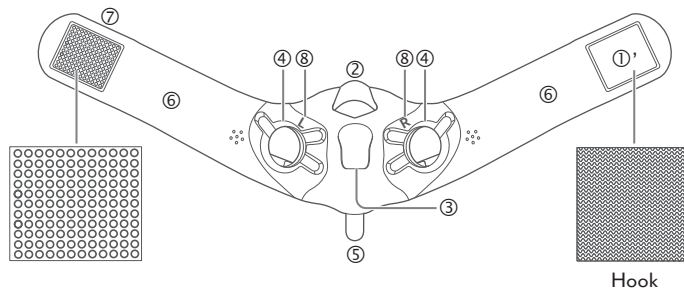

The controllers are attached to the silicone mask. The mask holds the controllers in place during the facial stimulation from the device.

Description of the silicone mask

No	Name	Description
① ①'	Hook and loop fastener	Secures the mask on user's head.
②	Nose guide	The user adjusts his/her nose to this guide.
③	Mouth opening	The user adjusts his/her mouth to this opening.
④	Attaching hole for controllers	The user attaches the controllers to this hole.
⑤	Tab	The user pulls the tab to adjust the placement of the mask.
⑥	Stopper band	Straps the mask on user's cheek to head.
⑦	Slip resistance	Prevents the mask from slipping on user's hairs.
⑧	Marking for the controllers	The controller labeled R is attached to the hole under "R" marked on the mask. The controller labeled L is attached to the hole under "L" marked on the mask.

AC Adaptor

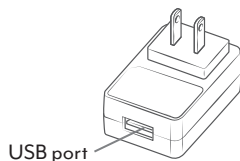

Magnetic USB Cable

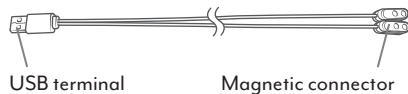

Note: Each connector can be connected to either left or right controller.

Extender Belt

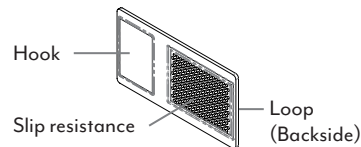

* For the Out side of United States, the AC adaptor is not contained in the package. You can use the adaptor which must have following outputs:

Output Voltage: 5V DC nominal.

Output Current: 0.5A (500mA) minimum.

Output Connector: Micro-B USB Connector.

CAUTION

- Before each use, check the device components and parts for any cracks, deformation, or other damage.
- **Do not** use if you see any sign of damage to avoid injury or malfunction.
- **Do not** use the device in humid places such as in a bathroom, in or near water, or outdoor to avoid injury or failure of the device.

Charging the device

1 Let the device sit at room temperature for 60 minutes.

Note: You can charge the controllers at the same time. Unplug the device before use.

2 Before first use, charge the device as shown in 4.

The charging pins on the controllers can be attached to the USB cable charger through magnets. Move the end of the USB charging cable with the magnetic connector side toward the front of the controller. The charging pin and magnetic end of the USB charging cable will show a magnetic attraction to assist with correct placement for charging.

Note: The LED on the controller will flash when the device is charging. If the LED does not flash, check the connection.

3 Plug the USB terminal of the cable into the USB port of the AC adapter.

4

Plug the AC Adapter into a wall outlet.

Check that the LED light is flashing in blue. Charge the device until the LED light has turned solid blue or turned off. When the device is fully charged, blue LED lights up for one minute, then the light turns off. Unplug the AC adapter and the USB cable after the battery is fully charged.

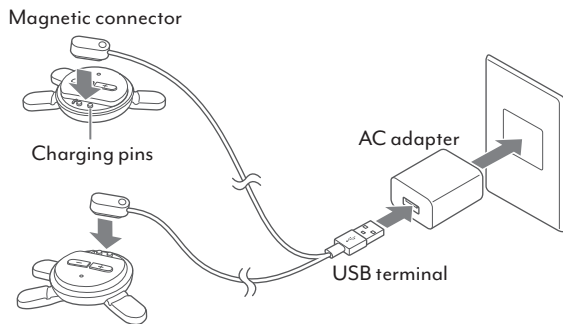

Note: It may take up 2 hours to fully charge at room temperature 25°C (77°F). A fully charged device can be operated up to about 4.5 hours.

CAUTION

- To avoid damage or injury, **do not** use an extension cord. **Use only** with the AC adapter included with the device.
- **Do not** charge the device if the device, AC adapter, USB cable, or socket is wet to avoid risk of electrical shock, short circuit, or fire.
- **Use only** the USB cable and AC adapter included in this package.

Note: This device cannot be used while the AC adapter is connected.

Preparation of the device

5 Place the back side of the silicone mask face-up on a table or flat surface.

The back side of the mask has a slip resistance sheet at the left tip and marks for the controllers.

6 Check the controllers for placement on the mask.

The back of each controller is labeled either "R" or "L." The controller labeled "R" must be attached under "R" marked on the right side of the mask.

The controller labeled "L" must be attached to the left side of the mask.

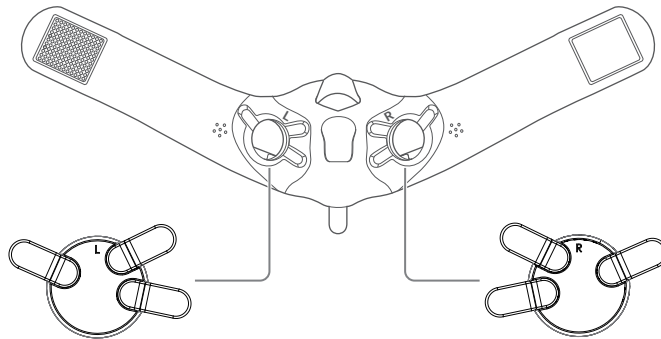

CAUTION

- Ensure the controller is tuned off when attaching it to the mask.
- **Do not** press the buttons on the controller while attaching the controller to the mask.

7 First, attached the Left side controller to the Left side of the mask.

Adjust the position of the controller with grooves and holes in the mask and press the controller down until the controller is attached to the mask.

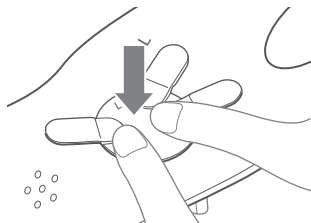

CAUTION

Do not use the excessive pressure when attaching the controllers to the silicone mask. The excessive pressure may cause damage to the controller.

8 Attach Right side controller to the mask in the same way.

Preparing for a muscle toning session

9 Tie your hair back if it is long to avoid catching the hair between the mask and your skin.

10 Wash your face to remove make-up, oils, creams and lotions.

Use the device only on clean skin.

Note: Some cosmetics may enhance friction between the electrodes and your skin during EMS treatment and transferring black colorants of the electrodes to your skin.

11 Moisten or spritz your cheeks with tap water.

Your face should be moist when using the device.

Note: EMS will **NOT** be delivered to skin unless there is water between the electrodes and your skin

CAUTION

Do not apply so much water so that it is dripping from your cheek. **Do not** get the controllers wet. If water enters the inside of the controller, it may cause electrical shock.



Applying the silicone mask to your face

12 Sit in front of the mirror.

Place the back side of the silicone mask with the controllers face-up on the flat surface.

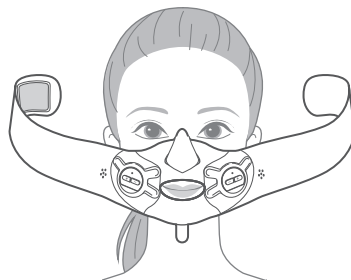

13 Hold the mask with both hands and place the mask on your face.

Adjust the mask under your eyes, the nose guide on your nose, and the mouth opening on your mouth.

CAUTION

- Avoid catching your hair between the mask and your skin.
- Do not twist the stopper band.

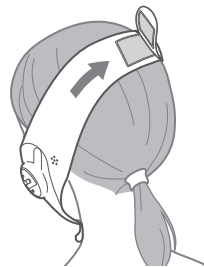

14 Pull the stopper band diagonally upward so that your ears are covered by the mask.

Secure the mask on your head and face with the hook and loop fasteners.

If the silicone mask is a lack of length for you, attach the extender belt to the silicone mask.

Note: Place the left hook and loop fastener under the right one

Note: Place the stopper band in a position where it can be firmly stopped without slipping from the head.

It may be easier to fix the stopper band by tying hair at the back of the head.

Note: If the nose part of the mask separates from your nose when the mask is secured on your head, the mask may be positioned too low. If so, detach the mask and return to step 13. The securing position should be at the top to middle of your head.

- 15** Pull the tab under your chin and adjust the mask so that it covers your lower jaw line. If the mask does not cover your lower jaw line, the mask is not worn correctly. If such case, detach the mask form your face and return to step 13.



- 16** Check in a mirror that the silicone mask is positioned as shown in the picture.

The mask should be attached firmly to your face.

Note: Depending on facial shape, there may be space between the mask and your skin. Adjust the mask with the chin tab to ensure that the controller electrodes contact your skin.

CAUTION

- Be sure the electrodes from the controllers on the back of the silicone mask are in contact with your skin. The overall area of each electrode should be in contact with your skin. If there is no contact between the electrodes and the skin, you may not receive the effect of EMS.
- **Do not** apply an oil treatment product to your hair prior to use to avoid the mask slipping from your head.
- Be sure there is always enough water between your skin and the electrodes. If there is not enough moisture, EMS transmission becomes inefficient and may cause decreased effects or discomfort including pain.



Treatment

- 17 Turn the power ON by pressing +/ON buttons on left and right controllers for at least one second simultaneously.**

Note: A long beep will sound and the lamp will light in pink when the device turns on.

Note: When the power turns on, no current is generated.

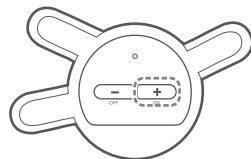

- 18 Select EMS intensity by pressing +/ON buttons to increase the intensity or -/OFF buttons to decrease the intensity.**

Note: The EMS intensity has levels from 0 to 5. The short beep will sound when you press the +/ON button or the -/OFF button on the controller. If you reach level 0 which the controller generates no current by pressing -/OFF button or level 5 which is maximum intensity by pressing +/ON button, the long beep will sound. Please see shown below.

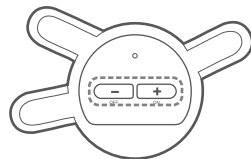

Intensity	Button	Sound
Level 0 (no output)	-/OFF button	Long beep
Level 1 (minimum intensity) to Level 5	+/ON button or -/OFF button	Short beep
Level 5 (maximum intensity)	+/ON button	Long beep

Note: Select Level 1 for your first treatment or until you become accustomed to the operation and treatment.

CAUTION

- **Do not** select the intensity which you feel a painful sensation.

- 19 Turning off the device.**

The device will automatically turn off 10 minutes after turning on the device. When the device automatically turns off, you will hear 3 long beeps. The LED light will turn off.

Note: We recommend that you perform the treatment for 10 minutes per a day.

Note: To stop the device during use, press "-/OFF" button of the right and left controllers for 1 second or more. When the device manually turns off, you will hear 2 long beeps and the LED light will turn off.

Cleaning your device

Note: Clean the mask after every use.

20 Detach the controllers from the silicone mask.

21 Wipe off any dirt on the controllers and electrodes using a damp with water soft cloth.

CAUTION

- To avoid an electrical shock, short circuit or a fire, ensure to turn off the controllers before detaching from the mask.
- **Do not** immerse the controllers and electrodes in water or other liquid.
- To avoid damaging the device, **do not** wipe the controller and electrodes with thinner, benzene, nail polish remover, or any liquids other than water.

22 Wash the silicone mask with warm water.

CAUTION

- **Do not** use hot water.
- **Never** use alkaline detergent such as stain remover, thinner, or nail polish remover.

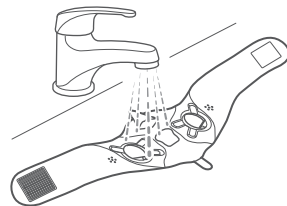

23 Wipe off any moisture with a dry cloth such as a towel.

24 Allow the mask to dry in a well-ventilated place until it is completely dry.

Note: Leaving the device without removing dirt or moisture may cause mold, discoloration or odors.

Storing the Device

The device can be stored in a place that is -25°C (-13°F) to 5°C (41°F). It can also be stored in 5°C (41°F) to 35°C (95°F) as long as the humidity is no more than 90%, non-condensing. >35°C (95°F) to 70°C (158°F) at a water vapor pressure up to 50hPa.

Do not use, charge, or store if the device is hot.

Store the device in a clean, dry, well-ventilated place.

Keep out of the reach of children.

To avoid risk of fire or explosion, do not use, charge, or store near fire, in direct sunlight, near heating equipment, or in humid places such as the bathroom.

Remove the charging USB cable from the controllers and the USB port when not in use for a long time and store them safely.

Maintenance and Disposal

To avoid electric shock, short circuit, or fire, **do not** leave the device on when cleaning or when not in use.

Battery

This appliance contains batteries that are non-replaceable.

Do not attempt to replace the battery yourself. Please contact YA-MAN USA if there are any issues with your device or if you need a replacement battery.

The battery can be charged approximately 300 times. The rechargeable battery is a consumable item and is not covered under the warranty. Do not use the device if the battery powers the device for an extremely short period of time after charging.

AC adapter

The AC adapter has an expected service life of 5,000 hours.

Silicone Mask and Extender Belt

Please contact YA-MAN USA if you need to replace the mask.

Disposal

The lithium ion batteries in the device are not removable by the user. Do not place the batteries near. Dispose of the device and batteries in accordance with local regulations.

Do not dispose of any part of this device by a fire.

Troubleshooting

If you need help setting up, using, or maintaining the device, please contact YA-MAN USA.

To avoid fire, electrical shock, or injury, do not disassemble, attempt to repair, or modify this device in any way.

Issue	Possible cause and solutions
No sensation or weak sensation is felt	● Raise EMS intensity with +/ON button (P.19).
	● The electrodes may not be touching your skin. Adjust the placement of the mask to ensure contact of the electrodes to your skin (P.17, 18).
	● Your skin is dry. Lightly moisten your cheek with tap water.
	● Low battery. Remove the device from your face and charge the battery (P.12, 13).
Tingling or painful sensation is felt.	● Decrease EMS level with -/OFF button (P.19).
	● Your skin is dry. Moisturize your skin with tap water.
Feeling difference between right and left of the face in EMS sensation	● Clean the electrodes (P.20).
	● The electrodes may not be touching your skin. Apply the silicone mask firmly (P.17, 18).
	● Your skin is dry. Lightly moisten your cheek with tap water.
	● Adjust the intensity of each controller to have a similar strength of the sensation.
	● Strength of sensation may be different between left and right if starting at different times.
	● Low battery. Remove the device from your face and charge the battery (P.12, 13).
● You may not feel the same sensation because of differences in positioning the controllers on your cheek between the right and left sides of your face. Adjust applying position of the mask to get stimulation on muscle.	

Issue	Possible cause and solutions
The power of the controllers does not turn on	<ul style="list-style-type: none"> ● Press "+/ON" button for approx. 1 second (P.19). ● Low battery. Charge the battery (P.12, 13).
The device only operates for a few minutes even after charging	<ul style="list-style-type: none"> ● The device will automatically turn off approx. 10 minutes after turning on. ● Low battery. Remove the device from your fare and charge the battery (P.12, 13). ● The battery life has ended. Contact YA-MAN USA for a new battery. ● Battery is not properly charged. Be sure that the blue lamp is blinking when charging.
The controller does not start charging	<ul style="list-style-type: none"> ● Plug the AC adaptor into wall socket (P.13). ● Connect the charging USB cable to the device (P.12, 13).

Frequently Asked Questions



How often should I use the device?

A

We recommend using the device once a day for 10 minutes.

Note: The device will automatically turn off 10 minutes after the EMS intensity is selected.



How much water should be used on the cheek?

A

Moisten your cheek but do not apply so much water so that it is dripping.

The controllers are not waterproof.

If there is insufficient moisture, you may feel tingling sensation.



Can I use the device in the bathroom?

A

Do not use the device in the bathroom. The controllers are not waterproof.



Can I use the device during my sleep?

A

Do not use the device while you sleep.



What should I do if I feel a difference between right and left of the face in EMS sensation?

A

Many people may feel uneven stimulation on the right and left sides of their faces.

Adjust the intensity of each controller to have a similar strength of the sensation on each side.



What should I do if my skin gets outbreaks of a rash, inflammation and itchiness after using the device?

A

A slight redness which fades quickly of the skin may occur after using the EMS device. If you develop a rash or swelling or redness persists for more than 24 hours, consult a physician.

Q What should I do if I feel physical discomfort and fatigue?

A Immediately stop using this device and consult a physician.

Q What should I do if I feel tooth pain?

A You may feel tooth pain when you are undergoing dental treatment or having silver-crowned tooth. If you feel discomfort when using the device or after use stop using the device and consult a physician.

Q Are there any contraindications for use of this device?

A Yes. Please read carefully all contraindications in this manual.

Q Can I use the device right after shaving or sunburn?

A It may cause inflammation.
A If you experience any skin problems, immediately stop using the device and consult a physician.

Q What should I do if I get redness on my skin?

A Redness may be caused due to pressure of the silicone mask. Consult a doctor if any redness lasts more than 24 hours.

Q Why is there black dirt rubbed off after cleaning the electrodes?

A Color may be transferred if the electrode is firmly rubbed.

Specifications

Model Number	EPM-I8-G	
Dimensions	Silicone mask: W580×H170 (mm)	Controller: W90×H55×D20 (mm) (one piece)
Weight	Silicone mask: 120g	Controller: 28g (one piece)
Input of AC Adaptor	100-240Vac 50/60Hz 0.3A	
Output of AC Adaptor	5Vdc 0.6 A	
Power consumption	1W (AC input, When the device charging with AC adaptor)	
Classification	Internally powered equipment, Class II charger, Type BF applied parts.	
Electrode area	5.04 cm ²	
Waveform	Symmetrical bi-phasic and quad-phasic square waveform when measured into a resistive load.	
Rated output(@500Ω)	Maximum Voltage: 39.3V ±20% (peak to peak) Maximum current: 3.22mA ±20% (@1kHz) (r.m.s.) Maximum power density: 1.0 mW/cm ² ±20% (@1kHz)	Frequency: 2.5/5/6/7/8/9/10/20/25/33/50/66/100Hz,1kHz Phase duration: 38/42/48 μs ±10% (@2.5-100Hz), 26μs ±10% (@1kHz) Pulse width: 152/168/192 μs ±10% (@2.5-100Hz), 52μs ±10 (@1kHz)
Expected service life of the equipment	4 years (The manufacturing date is provided on the carton label and the manufacturing year and month is included as a part of the serial number)	
Operating Environmental conditions	5 to 45°C (41 to 113°F), 15 to 90%RH, non-condensing, but not requiring a water vapor partial pressure greater than 50hPa., range of 700hPa to 1060hPa.	
Storage Environmental conditions	-25°C (-13°F) to 35°C (95°F) as long as the humidity is no more than 90%, non-condensing and 35°C (95°F) to 70°C (158°F) at a water vapor pressure up to 50hPa.	
Components	Silicone Mask/ Extender Belt/Controllers AC adapter/USB Cable Booklet User Manual	

Electromagnetic Information

Test	Standard	Class/Test conditions	Test result
Emission (IEC60601-1-2:2014 Clause7)			
Conducted disturbance at mains terminals	CISPR11	Group1, Class B on AC120V, 60Hz	Pass
Radiated disturbance	CISPR11	Group1, Class B on AC120V, 60Hz	Pass
Harmonic current emissions	IEC61000-3-2	-	Not applicable
Voltage fluctuations and flicker	IEC61000-3-3	-	Not applicable
Immunity (IEC60601-1-2:2014 Clause8)			
Electrostatic discharge	IEC61000-4-2	±8 kV contact discharges & ±15kV air discharges	Pass
Radiated, radio-frequency, electromagnetic field	IEC61000-4-3	10V/m, 80MHz to 2700MHz, AM80% 1kHz	Pass
Proximity fields from RF wireless communications equipment	IEC61000-4-3	As shown in Table 9 of IEC 60601-1-2: 2014.	Pass
Electrical fast transient /burst	IEC61000-4-4	±2kV	Pass
Surge	IEC61000-4-5	±0.5kV, ±1kV, 0,90,180,270degree	Pass
Conducted disturbances, induced by radio-frequency fields	IEC61000-4-6	3V, 0.15MHz to 80MHz, AM80% 1kHz	Pass
Power frequency magnetic field	IEC61000-4-8	30A/m, 60Hz, X/Y/Z	Pass
Voltage dips, short interruptions and voltage variations	IEC61000-4-11	0% 0.5cycle (0,45,90,135,180,225,270,135 degree) 0% 1cycle (0 degree) 70% 30cycles (0 degree) 0% 300cycles (0, 180 degree)	Pass

■ Labeling and Signs



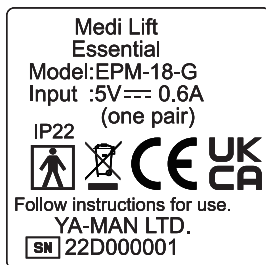

Controller's sign example

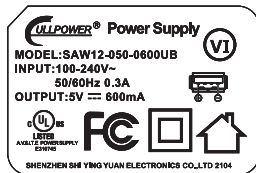

Symbol	Number of Standard	Meaning
	IEC60417-5031	Direct current (DC)
IP22	IEC60529	Solid particle protection is class 2, and Liquid ingress protection is class 2.
	IEC60417-5333	Type BF applied part
	BS EN 50419:2005	Waste electrical and Electronic Equipment (WEEE) Disposal Waste electrical and electronic equipment must not be disposed of as unsorted municipal waste and must be collected separately.
	ISO15223	It means Serial Number. The two numbers preceding the letter denote the last two digit of the year of manufacture. The letter denotes the month of manufacture. January starts with "A". "F" means June and "L" means December etc.
	CE mark	The device complies with the requirements of the EMC Directive (2014/30/EU) and the requirements of the ROHS Directive (2011/65/EU) for the Restriction of Hazardous Substances in Electrical and Electronic Equipment.
	UKCA mark	The device complies with the requirements of the Electromagnetic Compatibility Regulations 2016 and the requirements of the Restriction of the Use of Certain Hazardous Substances in Electrical and Electronic Equipment Regulations 2012.

AC adaptor's sign



Symbol	Number of Standard	Meaning
	IEC60417-5172	Class II equipment
	IEC60417-5957	Marking to identify electrical equipment designed primarily for indoor use.
	FCC mark	The device complies with regulations established by the Federal Communications Commission relating to the amount of radio frequency emissions allowed such that other device are not adversely affected.
	UL mark	The product complies with UL's safety certification for power supplies for US and Canada.

YĀMAN

Manufactured by YA-MAN LTD.

Shingu BLDG., 2-4-2 Toyo, Koto-ku, TOKYO, JAPAN

Distribute by YA-MAN U.S.A. LTD

San Diego, CA 92121

<https://www.mediliftbeauty.com/>

USA Call 877-231-9074

International: hello@mediliftbeauty.com

Designed by YA-MAN in Tokyo, Japan Controllers Made in Japan

Silicon Mask, Extender Belt, Magnetic USB Cable and AC Adapter Made in China