



FITTING MANUAL

PRODUCT NAME : FRONT BUMPER
PART NO : OP 258
CAR MODEL : NISSAN NAVARA NP 300



MADE IN THAILAND



OPTION 4WD



option4wdofficial









info@option4wd.co.th

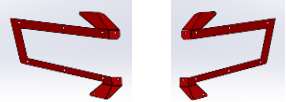
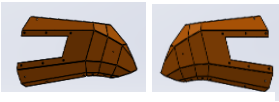
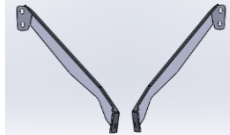
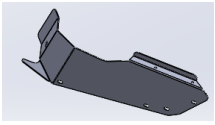

PART LIST

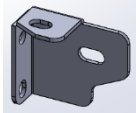
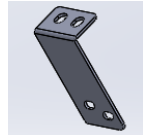
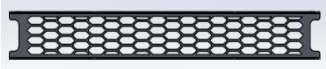
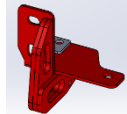
PRODUCT NAME : FRONT BUMPER

SUITE TO VEHICLE : NISSAN NAVARA NP 300

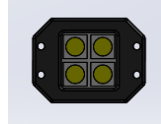
<p>1.</p>  <p>COVER 1 SET, (L+R)</p>	<p>2.</p>  <p>SIDE PART, 1 SET (L+R)</p>	<p>3.</p>  <p>SUPPORT 1 SET, (L+R)</p>
<p>4.</p>  <p>UNDER SIDE PART 1 SET (L+R)</p>	<p>5.</p>  <p>CENTER PART 1 PCS.</p>	<p>6.</p>  <p>UNDER CENTER 1 PCS.</p>
<p>7.</p>  <p>BRACKET 1 SET (L+R)</p>	<p>8.</p>  <p>COVER BRACKET, 1 SET (L+R)</p>	<p>9.</p>  <p>FRONT GUARD KIT, 1 PCS</p>
<p>10.</p>  <p>SPORT LIGHT BRACKET, 1 SET (L+R)</p>	<p>11.</p>  <p>CENTER SIDE 1 PCS.</p>	<p>12.</p>  <p>PLATE NUMBER BRACKET, 1 PCS.</p>
<p>13.</p>  <p>SUPPORT BRACKET 2 PCS.</p>	<p>14.</p>  <p>BRACKET 1 SET, (R+L)</p>	<p>15.</p>  <p>LED , 2 Pcs.</p>



FITTING INSTRUCTION

PRODUCT NAME : FRONT BUMPER
SUITE TO VEHICLE : NISSAN NAVARA NP 300

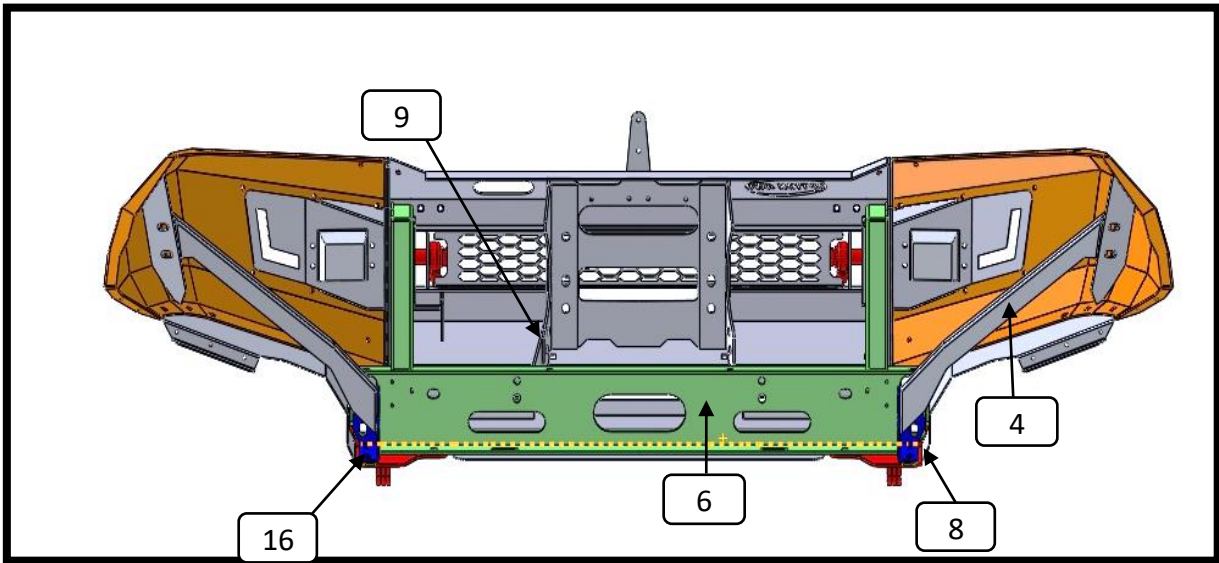
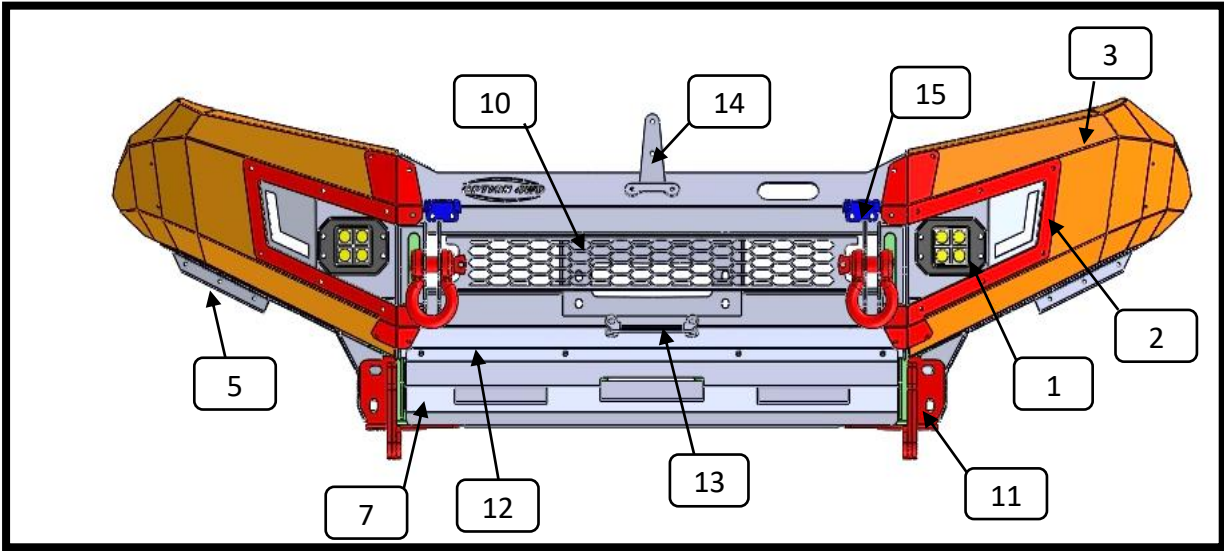



PART LIST

PRODUCT NAME : FRONT BUMPER

SUITE TO VEHICLE : NISSAN NAVARA NP 300

NO.	PICTURE	NAME	QTY	UNIT	NOTE
1		M6x1x20	52	Pcs.	
		Washers M6	52	Pcs.	
		Flange nut M6x1	32	Pcs.	
2		M10x1.25x30	16	Pcs.	
		M10x1.25x30	8	Pcs.	
		Sping Washers M10	20	Pcs.	
		Washers 3/8	48	Pcs.	
		Flange nut M10x1.25	24	Pcs.	
3		Cage nut M6x1.0	20	Pcs.	
4		M12x1.25x100	2	Pcs.	
		Washers M12	4	Pcs.	
		Hex nut M12x1.25	2	Pcs.	
5		M8x1.25x20	4	Pcs.	
		MS M8	8	Pcs.	
		SW M8	4	Pcs.	
		FLANG NUT M8x1.25	4	Pcs.	



Torque Setting of Fastener

Mounting bolts must be tightened to torque's specified following ;

bolt Diameter (mm.)	Torque (Nm)	Torque (ft.lb)
M8	22	16
M12	77	57

Fitting Instructions FRONT BUMPER NAVARA NP300

Installation Both left side and right side are alike.

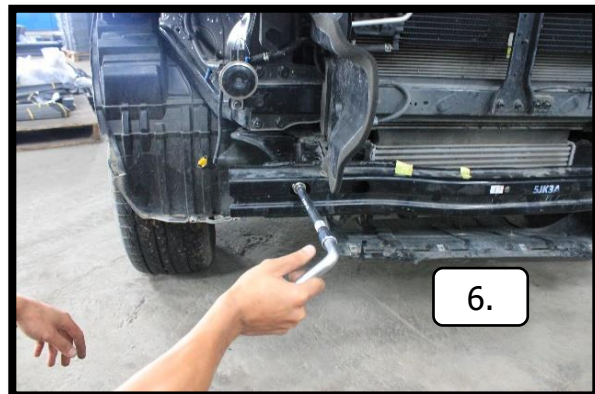
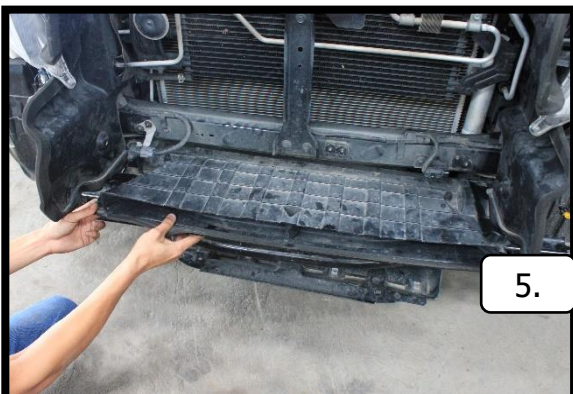
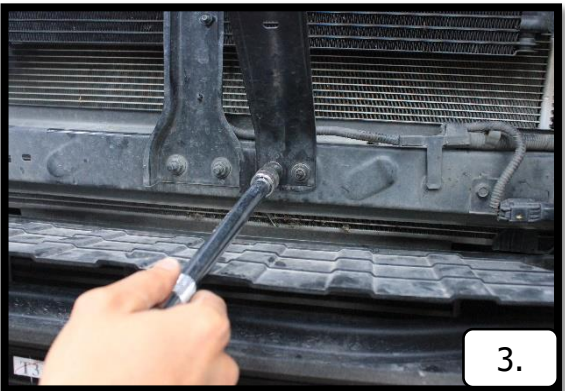
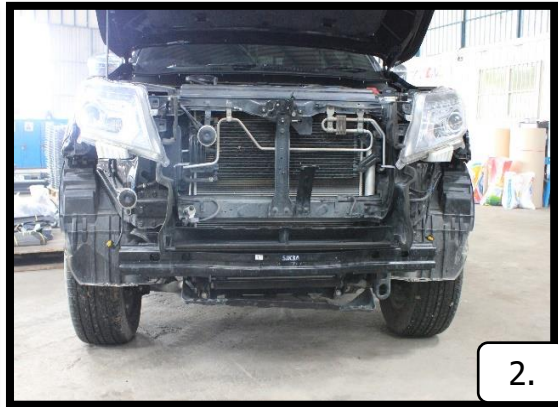

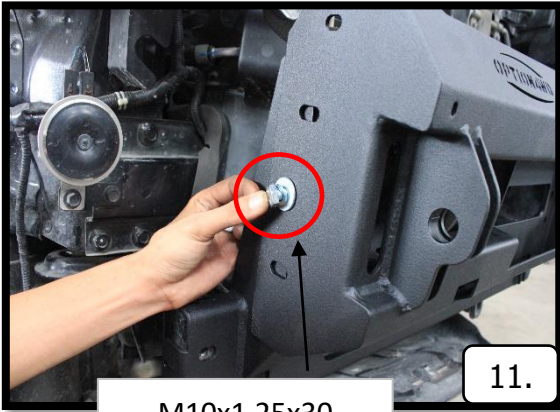
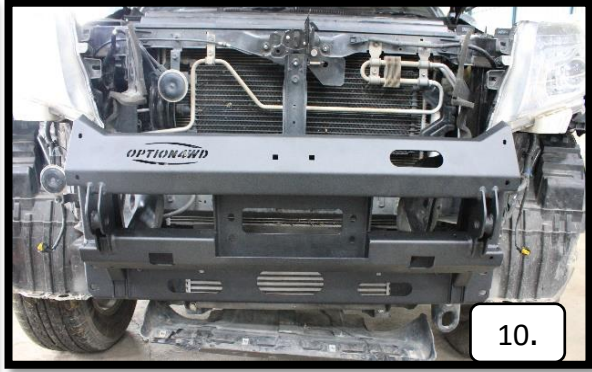
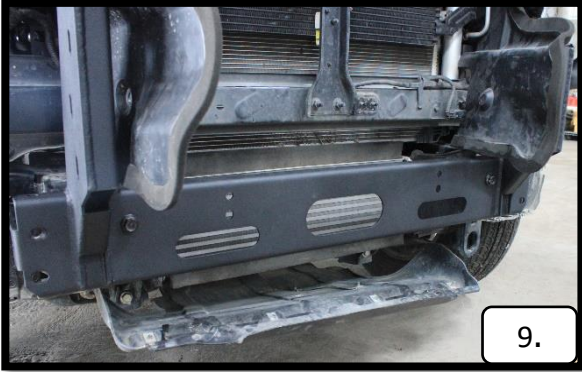
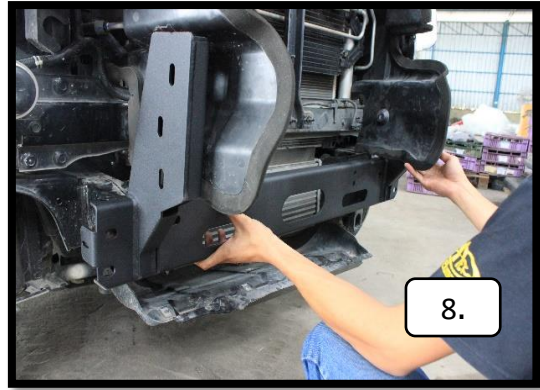

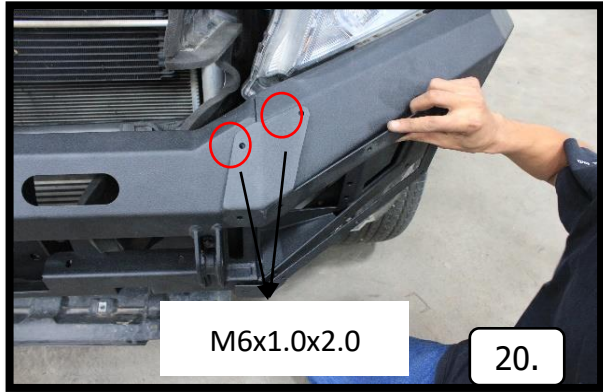
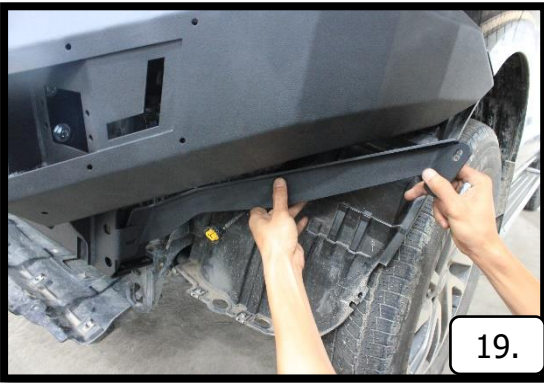
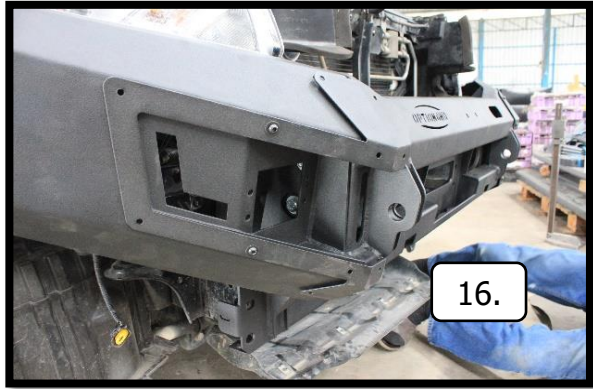

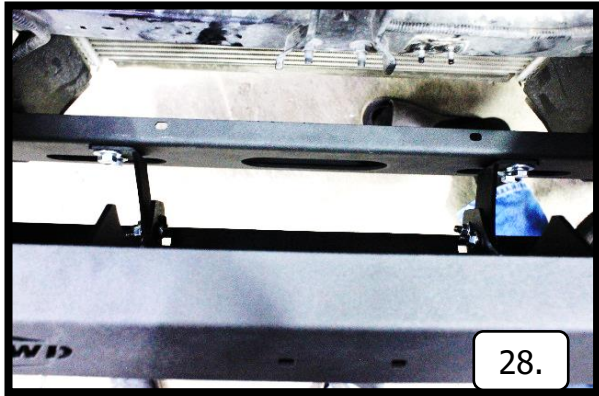
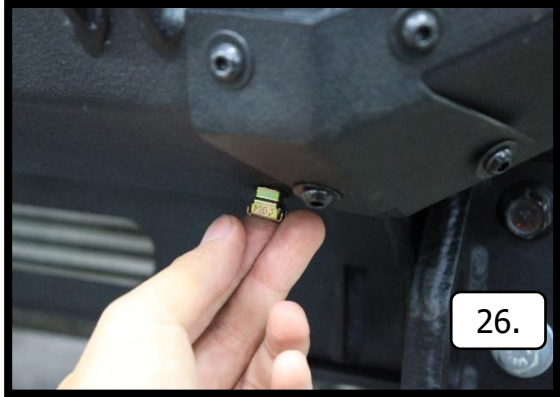
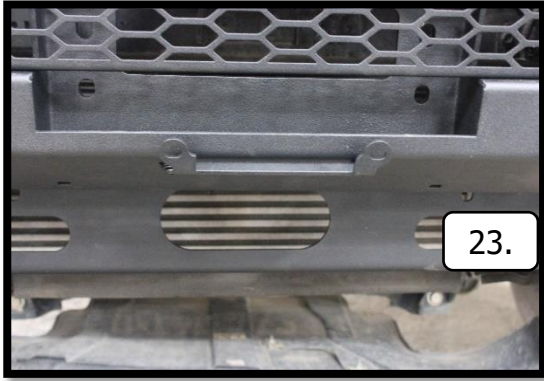



OPTION 4 WHEEL DRIVE CO.,LTD.