

Royal Victorian Greenhouse

VI23,34,36,46



Exaco Edits 03.01.23
Janssens Version 2022_4

ASSEMBLY INSTRUCTIONS

Note: This is an all-inclusive manual. It shows optional accessories and customizations that may not apply to your greenhouse. Direct any questions to Exaco.



***Assembly Videos can
be found by scanning
the code to the left
with your
smartphone.***



www.exaco.com

877-760-8500

Or find the link to our YouTube page at www.exaco.com. Go to the Victorian Greenhouse Playlist for all videos.

Table of Contents

Introduction & General Information.....	5-16
Basic Assembly Order of Greenhouse.....	5
Required Tools.....	6
Safety Considerations.....	6
Helpful Suggestions.....	6
Greenhouse Version Layouts and Diagrams.....	7-9
Doors and Door Optional Upgrades.....	9-11
Windows and Window Options.....	11-12
Optional Accessories and Upgrades.....	12-13
Placement of Greenhouse.....	13
Foundation and Anchoring.....	13-14
Greenhouse Floor.....	14
Water and Electricity.....	14
Ventilation and Cooling.....	15
Heating the Greenhouse.....	15
Using the Greenhouse as Additional Living Space.....	16
Maintenance.....	16
Foundation Measurements and Planning.....	17-20
UPGRADE OPTION: Planning/Building a Stem Wall.....	18-20
UPGRADE OPTION: Sliding Door/s on a Stem Wall with Drop Door Kit.....	19
UPGRADE OPTION: Hinged Door/s on a Stem Wall with Drop Door Kit.....	20
Packing List.....	21-22
Glazing Specs.....	23-24
Diagram of Greenhouse Extrusions/Profiles.....	25
Assembling your Greenhouse Frame	
Foundation Frame and Side Walls.....	26-32
Building the Roof.....	23-44
Retro Greenhouse Assembly.....	45
Gutter Downspouts and Roof Decorations.....	46

Installing the Glazing.....	47-53
Important Glazing Installation	47
Polycarbonate Glazing Procedures.....	48
Glazing and Gasket Installation.....	49-53
Door Assembly and Installation.....	55-78
Standard Kit Sliding Door Assembly and Information.....	55-60
UPGRADE: Sliding Door on a Wall with Drop Door Kit.....	61
UPGRADE OPTION: Sliding Door Low Threshold Installation.....	62-66
UPGRADE OPTION: Hinged Door Installation.....	64-79
UPGRADE OPTION: Door Fly Screen.....	80
Window and Vents.....	81-85
Roof Window/Vent Assembly/Installation.....	81
Roof Vent Openers.....	82-84
UPGRADE OPTION: Roof Vent Fly Screen.....	85
Louvered Window Assembly/Installation	86-88
Louvered Window Cover.....	89
UPGRADE OPTION: Louver Vent Fly Screen.....	90
UPGRADE OPTION: Push Out Window Assembly.....	91-93
Shelving Options	
OPTIONAL ACCESSORY: Narrow Top Shelf Assembly.....	94
OPTIONAL ACCESSORY: 2 Slat Shelf Assembly.....	95
OPTIONAL ACCESSORY: 5 Slat Shelf Assembly.....	96
OPTIONAL ACCESSORY: Seed Bed/Tray Assembly.....	97
UPGRADE OPTION: Shade Cloth Assembly.....	98-100
Misting System.....	101
UPGRADE OPTION: Exhaust Fan Installation.....	102
Customer Service Information.....	104



Customer Service or Assembly Questions?

Give us a call: 1-877-760-8500

customerservice@exaco.com

www.EXACO.com

Please watch our animated assembly videos on our
Exaco YouTube Channel.

Find the link at www.exaco.com

OR

Scan the code below:



Thank you for purchasing a Janssens' Royal Victorian Greenhouse, imported and distributed in North America by Exaco in Austin, TX. Exaco will provide all the North American based customer support for you greenhouse. Please feel free to reach to Exaco customer service with any questions you may have during assembly!

Questions? Need Assembly Support?

Please call Exaco at 877-760-8500 or email customerservice@exaco.com.

Introduction

In this manual, you will find the assembly instructions for all basic/standard-model greenhouses. However, this manual also contains pages which apply to optional accessories that may not be included with your kit. Victorian greenhouse "kits" vary by retailer. Some retailers may bundle additional accessories with their greenhouses - please check your order closely so you understand which accessories your greenhouse includes before building. It is also very helpful to plan out where each of these additional accessories will go to determine if you need to insert bolts/hardware during the build.

This greenhouse is designed for cultivation of plants/flowers. Therefore leakage, water drops and condensation inside the building are allowed. The building may only be entered by competent persons during cultivation or maintenance. Painted aluminum profiles/extrusions are powder-coated for a durable finish. The rubber strips have been treated with oil/silicone on the interior to facilitate the assembly. The building should be mounted on a solid concrete foundation deep enough to get a solid and frost-free ground. Anchoring of the foundation is vital and should be checked periodically. During winter, the roof will need to be cleared of snow or supported in a suitable way (see additional notes in "Maintenance" section). The greenhouse should be built in a location protected from strong winds. Protective gear (such as gloves) should be used during assembly in order to avoid injuries. One should at all times pay attention to the local building regulations.

The Royal Victorian greenhouse has been engineered and manufactured in Belgium using the metric system. We strongly recommend having a metric or combination tape measure on hand during assembly. We have converted and added inches to the manual when feasible – however for the most accurate and precise measurements some do still remain in metric. Conversion of metric to inches results in unusual fractional increments or decimals that become difficult to measure on a standard US customary ruler/tape measure. Using the metric system keeps your measurements more precise. If you prefer to work only in inches, you may use a converter tool available in app stores for smart phones.

Basic Assembly Order of Greenhouse

- Preparing your site – must be level and accommodate anchoring of the structure (see section on "Foundation and Anchoring")
- Sorting of the profiles/extrusions according to the model/size of greenhouse. The aluminum profiles (extrusions) are identified by their cross-section and length. It is helpful to have a metric or combination tape measure for this.
- Assembly of the complete aluminum framework

- Leveling of the construction using a level
- Anchoring/securing of the greenhouse to the ground
- Glazing installation

Required/Recommend Tools

- Metric or Combination Measuring Tape (highly recommended)
- Socket wrench or spanner - 10mm (it is helpful to have multiple)
- Needlenose or other pliers (helpful when installing corner posts)
- Level
- Screwdrivers (Phillips and Flathead)
- Drill + bits
- Impact driver and 1/2" drill bit (useful to notch channel to insert missed bolts)
- Scissors (to cut the rubber)
- Stable Ladder at least 6' tall

Safety Considerations

- Glass safety
 - Store the tall pallets of glass on firm level surfaces ONLY.
 - Keep your glass pallet dry! Moisture can cause the panes of glass to stick together and may be difficult to separate.
 - Important! Please follow glazing removal instructions on the pallet for steps to safely remove glass panes from the pallet. Contact Exaco if you have not seen these steps!
 - Tempered glass is surprisingly strong. The corners are the most vulnerable – please be aware of the corners when handling and installing glass.
 - Use a quality glass suction cup when handling glass, gloves are recommended.
- Watch your step! Be sure ladders are securely placed before climbing them.

Helpful Suggestions

- Understand which greenhouse accessories you have and where they will be placed. There will be prompts throughout the manual to insert bolts during assembly for doors, window, shelves, shade cloth, misting system, etc.
- If you forget to add a bolt where one is needed, you may create an insertion point in the channel with a 1/2" drill bit and an impact driver. If possible, do it in a place that will be covered by the piece you will be attaching. We do also have hammerhead/T bolts available for purchase that may be added later.
- Look through the entire manual and watch the assembly video to help you prepare and understand the greenhouse assembly process.
- You may start with assembly of the doors and roof windows. This helps create familiarity with the materials and construction process and gives a head start when it comes to assembly time.
- **The stainless-steel hardware included with your greenhouse is preferred for damp greenhouse settings. This high-quality metal is malleable however, and the heads of the screws can be stripped or break if proper precautions are not taken. Set your driver**

(impact driver is preferred) to a low setting and hand tighten the screw at the end to avoid snapping the screw head.

Please thoroughly read the email that was sent to you from Exaco customer service for additional addendums to the manual and other important information.



Refer to the Exaco YouTube Playlist for the Victorian Greenhouse for animated assembly videos as well as specific installation videos regarding your greenhouse. This playlist is also accessible via the QR code to the left.

Questions? Need Assembly Support?

Please call Exaco at 877-760-8500 or email customerservice@exaco.com.



Royal Victorian Greenhouses come standard with the following: (additional accessories/kits may be added)

VI 23 (7'9" x 10'2") - Foundation frame/base, single sliding door, two roof vents (1 automatic opener, 1 spindle opener), one louvered window (with optional auto opener and winter cover), misting system, gutters and downspouts.

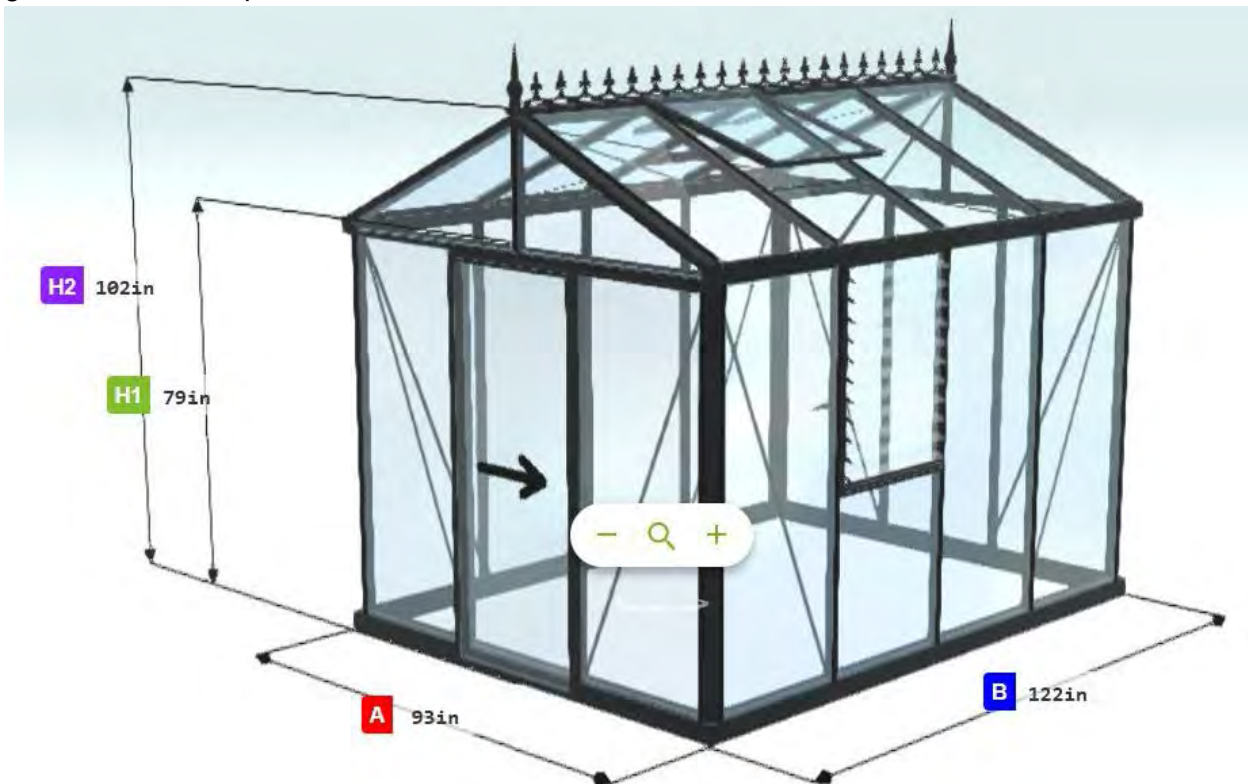

VI 34 (10'2" x 15') - Foundation frame/base, single sliding door, three roof vents (2 automatic openers, 1 spindle opener), one louvered window (with optional auto opener and winter cover), misting system, gutters and downspouts.

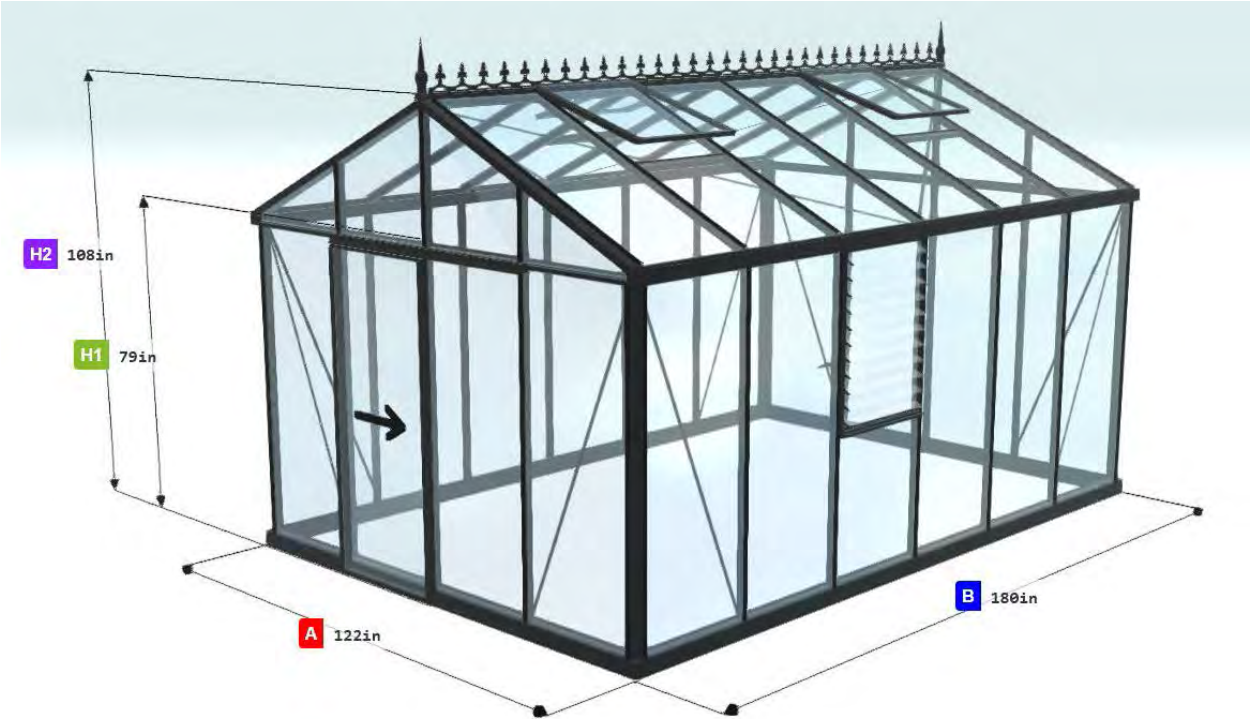

VI 36 (10'2" x 19'10") - Foundation frame/base, double sliding door, four roof vents (2 automatic openers, 2 spindle openers), one louvered window (with optional auto opener and winter cover), misting system, gutters and downspouts.

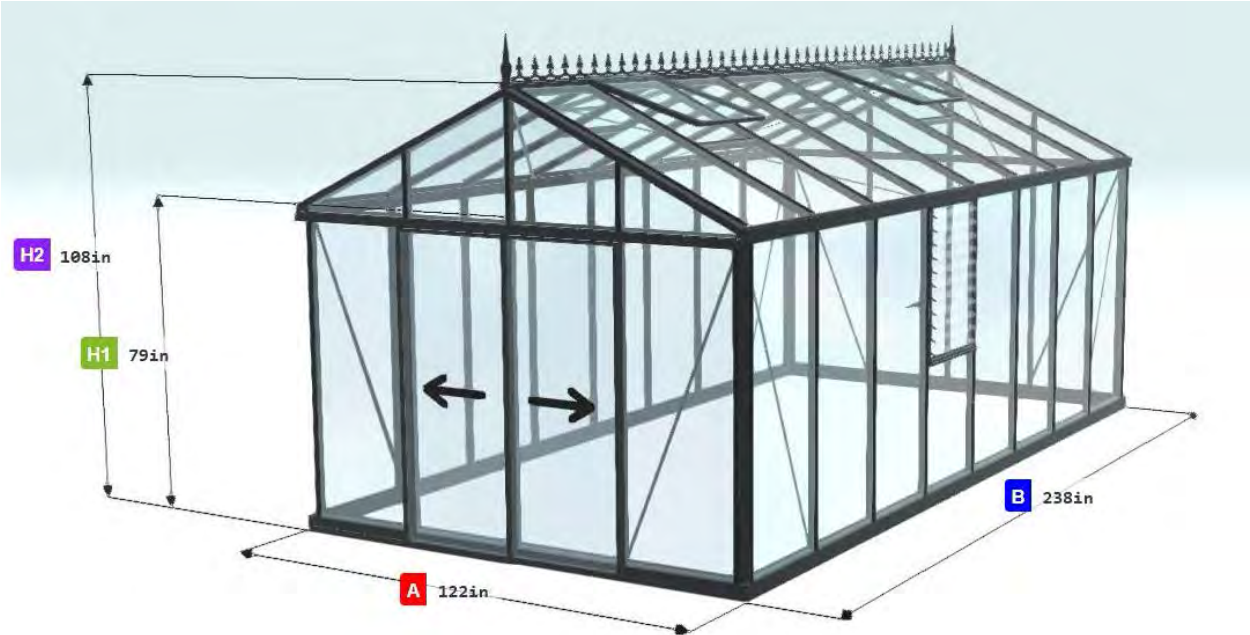

VI 46 (12'7" x 19'10") - Foundation frame/base, double sliding door, six roof vents (4 automatic openers, 2 spindle openers), one louvered window (with optional auto opener and winter cover), and misting system.

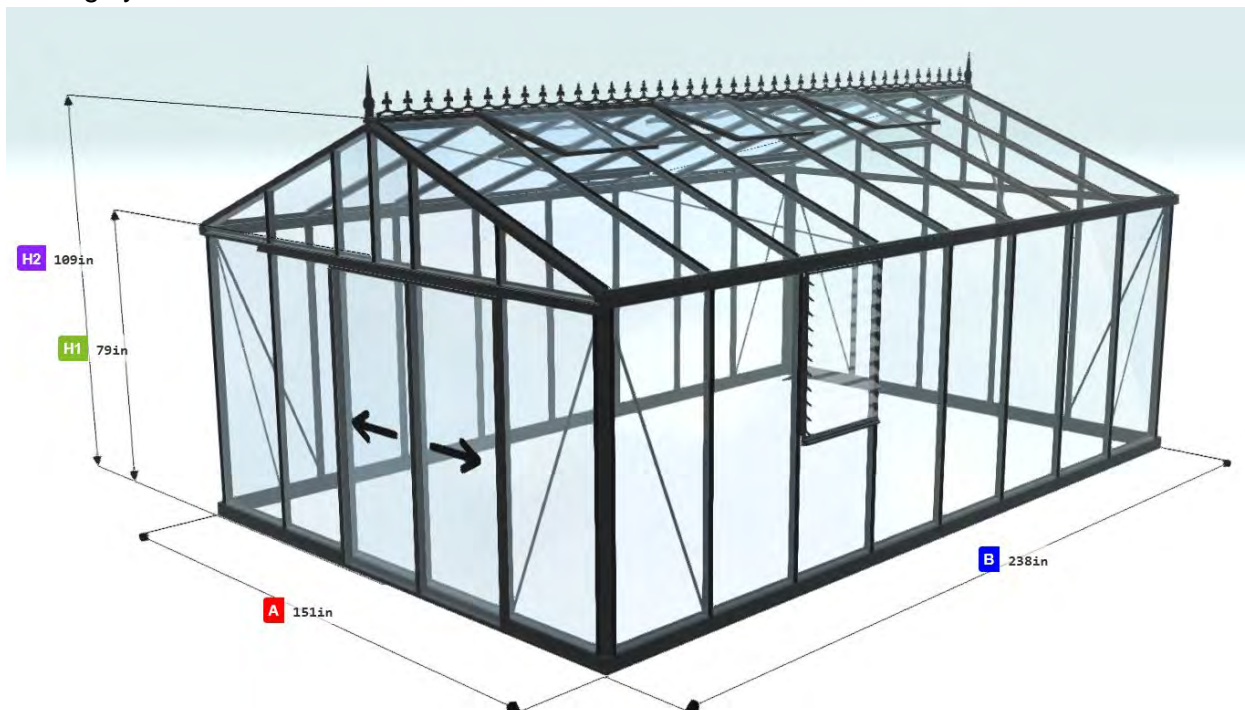

Doors

Royal Victorian doors may be placed on the long or short side of the greenhouse in any bay. Exceptions apply for corner placement, please call Exaco to discuss if you are considering this placement. Upgrades to additional single or double sliding doors and/or hinged doors are available.

Door Options:

- **Sliding Doors:** Single or double options are available. The sliding door/s of the greenhouse hang/slide along the outside of the greenhouse and feature brush weatherstripping. Keyed locks attached at the bottom of the door. Double doors will have no center support. For standard kits, the sliding door threshold will be the 4 ½" high base frame unless a low threshold kit (see below) is purchased. If you are building on a stem wall - please note special considerations for sliding doors on stem walls before building your stem wall.
- **Low Threshold Kits:** Standard greenhouse sliding doors will have the 4 ½" base frame as the threshold for the doorway. The upgrade to a low threshold kit requires cutting the base frame at the doorway to allow installation of a 1" high threshold to secure the sliding door guide and make walking in and out of the greenhouse easier. The premium low threshold kit now includes a full 4 sided frame for the door opening with lock at a more comfortable height. Available for single or double sliding doors.
- **Hinged Doors:** These are a very handsome upgrade, but are significantly more challenging. We recommend installation by a highly skilled handyman. The hinged doors are time-consuming, require adjustments, and special tools (such as a grinder) may be needed. The

doors are inset into the frame of the greenhouse and are further weatherproofed with rubber gaskets. The doors feature their own door jamb including low threshold and high-quality adjustable hinges for easier hanging. Traditional handles with a keyed lock will keep your greenhouse secure. Double or single hinged doors are available. A hinged door can be easier to work with if the greenhouse is placed on a stem wall. It is preferable to order a hinged door with the greenhouse as the hinged doors must be sent via freight truck and shipping costs can be prohibitive if shipped at a later date.

Number of doors vary by size of greenhouse:

- **VI 23** standard greenhouse includes one single sliding door. This model has 3 wall panes on the gable end and 4 on the longer side. A single door may be easily centered on the gable end, but will be placed off center on the long side.
- **VI 34** standard greenhouse includes one single sliding door. This model has 4 wall panes on the gable end and 6 on the longer side. A single door will not be centered on either wall. Upgrades to a double door are available if desired.
- **VI 36** standard greenhouse includes a double sliding door. This may be placed as a double door opening (with no center support) OR as two single sliding doors. This model has 4 wall panes on the gable end and 8 on the longer side. A double door opening may be centered on either side, a single door opening will not be centered. If placing a double door on the long side, please see note below regarding “Special Considerations for VI36 and VI46”.
- **VI 46** standard greenhouse includes a double sliding door. This may be placed as a double door opening (with no center support) OR as two single sliding doors. This model has 5 wall panes on the gable end and 8 on the longer side. A double sliding door may be centered on the long side (please see notes below on “Special considerations for VI 36 and VI46”), but can only be centered on the gable end with additional parts and customization on site (please see notes on “Customizing Door Placement”).
- **Retro Victorian Greenhouses** come standard with hinged double doors regardless of size and will also include push-out (top hang) window/s rather than a louvered window.

Special Consideration for VI 36 and VI46 Door Placement: These two models include a set of 3 Spandrels/Deco Scroll Supports to help support the long profiles/extrusions of the greenhouse. These attach at the gutters and ridge beam at the midpoint of the greenhouse. They will interfere with centering a double door on the long side of the greenhouse as the spandrel at the gutter needs to attach to the rafter and the vertical glazing bar. Find information on the spandrels in the table of contents.

There are a few options to remedy this while still centering the double door on the long wall:

- Purchase one additional spandrel to have a pair that may be installed to the left and the right of the door. The spandrel for the ridge and opposite gutter will remain at the midpoint. This option looks nice, provides sufficient support and will minimally interfere with a shade cloth. The shade cloth will still meet at the midpoint at the opposite gutter and ridge beam but will be separated at the doorway due to the spandrels.
- Purchase an additional set of three spandrels, install one set of three to the right of your doorway (at gutters and ridge) and the other set of three to the left of your doorway (at gutters and ridge). This is a good option for areas with heavier snow/wind requirements, but will interfere with the shade cloth - as it will not slide past the

spandrels. See shadecloth diagrams in the table of contents. If desired, you may purchase additional narrow panels of shadecloth to cover the sections where the doorway is.

Please note if you have your greenhouse on a stem wall with a “drop door” kit, the above methods are still recommended as it is best to shift the weight down to the glazing bars to the right and left of your double doorway rather than down the header (which is not supported).

Custom Centering a Door on a Wall

With additional parts and on-site customization, you may center a single door on a wall with an even number of bays - or a double door on a wall with an odd number of bays by creating narrow side lights on either side of your doorway. Please order one additional PRO1456 from Exaco to frame this extra pane. Once completed, you will need to purchase the narrower side light glass locally as this is a custom size that Exaco does not stock.

Windows

Each greenhouse will have a combination of roof vents and a louver side wall window. The roof vents allow hot air up at the ridge to escape, while the louver side wall window acts as an intake for cooler air. The roof vents are usually staggered and some placed on both sides of the ridge beam. Occasionally if there is prevailing wind from one direction, more windows may be placed on that side. We recommend the manual spindle opener be used for windows facing strong gusts of wind. The windows cannot be placed side by side. There are a variety of openers available for roof vent windows.

● Roof Vent Openers

- Manual Stick openers - these will be packaged in every roof window kit. They are entry level openers that work on a peg/notch system. Not recommended for daily use but may be used to “lock down” the window if needed (auto openers must be disengaged or your piston will burst).
- Manual Spindle openers - a high-quality stainless steel threaded rod to securely crank the window to desired open position with use of a removable long handle. These are heavy-duty and will hold up well to strong winds if needed.
- Automatic Opener (Ventomax) - this opener utilizes a piston that is filled with oil that expands between 68 to 70 degrees. The oil pushes out the rod of the piston to open the window. When the piston is engaged, there is no manual control of the window. If there is rain when the temperature is above 68 in the greenhouse, it is likely that the roof vent will be open and rain will come in. During the cold months the pistons may be disengaged if heating the greenhouse.

● Louver/Jalousie Side Wall Window

- Placed in a sidewall bay, often opposite the door for a cross breeze
- Comes with a manual opener installed or included auto opener (Sesam Liberty) may be installed
- If you are installing an exhaust fan, the louvered window with auto opener may act as your intake vent.

- **Push Out/Top Hang Side Wall Window** - optional upgrade that is included with Retro Victorian models. It hangs from a hinge at the top and the bottom pushes out. An auto opener may be used.

Optional Accessories

There are a variety of optional accessories available, some of which are listed below. Some retailers may bundle a shadecloth/shelves with their greenhouse kits.

- Shadecloth - interior shade curtains hang from the gutters and ridge beam. Sliders installed in these channels allow the curtains to be pulled open/closed.
- Shelves
 - Seed tray/Seedbed - in Royal Victorians the seed tray installs along the longest side of the greenhouse at your preferred height. The seed tray is 20" wide and has a 4" planting depth with a white polycarbonate bottom to allow for drainage. It is best to order at the same time as the greenhouse as it has to ship via freight truck due to the length.
 - Top Shelf - is 4" wide and it installs along the longest side of the greenhouse, either above the seed tray or on its own at your preferred height. It is best to order at the same time as the greenhouse as it has to ship via freight truck due to the length.
 - Slat shelves - extremely flexible in terms of height, usage, and all around placement. They are 59" long (across two sections of glass) and may be run end to end for a long stretch of shelving. They may also be centered across 3 panes of glass if desired. Slat design works well for holding pots/planters or it may be used for a work surface. These shelves may be shipped via FedEx or UPS.
 - 2 Slat Shelves - 9" wide x 59" long
 - 5 Slat Shelves - 21" wide x 59" long
- Fly Screens are a brand new addition from Janssens
 - Roof Window Fly Screen - easily installs into roof vent opening
 - Louver Window Fly Screen - clips onto outside of louvered window
 - Door Fly Screen - Slides along the INSIDE of the greenhouse so as not to interfere with the existing doors. May be used with sliding or hinged door (not compatible with hinged door auto closers). Not compatible with greenhouses placed on a wall.
- Ventilation - An exhaust fan may be installed in the gable of the greenhouse to blow out the hottest air. Replace a glass pane with a lexan panel into which you can mount the fan (polycarbonate greenhouse panels may be cut to accommodate the fan). Many exhaust fans will use an external thermostat to control at what temperature it turns on and off. Place an exhaust fan opposite your louver window to create a cross breeze. For the most effective cross breeze, it is often recommended to close window vents to force airflow through your louver window.
- Heaters - see below "Heating the Greenhouse"

Placement of the Greenhouse

The placement of the greenhouse varies by intended usage, climate, location, and space available. There is a wealth of information to be found online on this subject, here are some considerations:

- Will your greenhouse be in full sun or get afternoon shade? Glass greenhouses do what they are intended to do - heat up quickly on sunny days. Great for the winter, but depending on your climate, it can be a challenge during summer months. Think about what you will be growing as well as the seasonal usage of your new greenhouse to determine appropriate sun exposure. It may help to watch the seasonal variations of sun angles in your yard to determine the placement.
- Depending on what you are growing and where you are located, you may wish to orient your greenhouse east/west or north/south - many garden bloggers have weighed in on this and research may help you consider the options. In many areas of the US, we do get plenty of hours of sunlight. Some users end up placing the greenhouse based on layout/space available, aesthetics and convenience.
- The site must be level. If it is not, you will need to prepare the area to provide a firm and level surface to construct your greenhouse. This may include building a retaining wall or placing your greenhouse on a stem wall - or just leveling out the site. Consider rainwater flow in your yard if you are in a hilly area.

10

Foundation and Anchoring

All greenhouses must be securely anchored. All Victorian greenhouses include corner brackets attached to the foundation/base frame that extend an additional 12" below ground level. The VI 36 and 46 include an additional pair to use at the midpoint of the long wall. If you are in a very high wind area or are trying to meet the structural specifications for a permit - you may wish to purchase additional corner anchor posts (PRO210) for use at the vertical members.

The manufacturer recommends an 8" wide concrete strip foundation that extends down to the frostline in your area. Please consult your local building codes for this information. It is recommended to leave a 4" diameter hole at the corner for the anchors to be embedded in concrete after the greenhouse frame is assembled and it is confirmed to be level and square.

Alternatively, you may also choose to anchor the greenhouse by trimming the corner anchors off at ground level, cutting them in sections to be used as L brackets to secure the greenhouse frame to your anchoring surface with the appropriate hardware.

Some users have chosen a variety of alternative anchoring methods based on their climate, location, soil composition, and site considerations. These include full concrete slabs, concrete footers, pier and beam constructions, and even timbers. If you are considering the use of wood in your construction, be aware that your greenhouse will likely outlast your wood. If you use pressure treated wood, it is recommended to use a barrier material between the wood and the aluminum frame. When planning your anchoring method, you should keep in mind frost line/ground heaving, wind load, greenhouse location, ground composition, weather, climate, and local building code. If you are unsure, you should consult with a local and experienced builder. Warranty coverage does not extend to damage resulting from improper anchoring of the greenhouse outside of manufacturer's recommendations (see above).

If a permit is needed in your area, we do have structural certification letters and permit sets for most of our greenhouses. They are Texas stamped. We may be able to obtain other state stamped

documents, however if you need them specific to your state, we do not cover this expense. Please contact Exaco if structural documents are needed.

Flooring

The greenhouse does not include flooring material, allowing it to be customized to your needs and use. When planning your flooring, consider the intended use of the greenhouse, the plants that will be grown, drainage, heat sink benefits of the material, insulation, weed blocking, as well as aesthetics. If you use a natural flooring option - consider including a weed barrier. Here are a variety flooring options to consider:

- Soil - this is a great option if you have fertile soil and wish to plant directly into the ground. This can be used in combination with other options below.
- Pea gravel, crushed stone, etc. - provides natural drainage and some crushed rocks help with weed control
- Pavers and bricks - A very nice looking option with natural drainage capabilities. May also be used for paths in combination with in ground planting areas.
- Wood - Looks very nice, but requires more maintenance. Keep in mind that the wood may deteriorate before the greenhouse lifespan is over.
- Full concrete slab - This can double as your anchoring surface as well. Keep in mind that greenhouses can be wet environments so texture and drainage need to be considered.
- Tiling - this can be a beautiful option as well. If your greenhouse is a functioning greenhouse, consider water drainage. Tile may get very slippery when wet.

Water and Electricity

You may choose to bring water and electricity into your greenhouse. If possible, it is recommended to plan for this ahead of time so that you can plumb/wire underneath the base frame of the greenhouse. Generally users will bring electricity under the frame at the most convenient location and then attach conduit to the frame of the greenhouse to the desired location. Custom matched spray paint is available if needed.

The irrigation/misting system (included with Royal Victorians) may be directly plumbed or attached to a hose with a hose clamp (available at garden stores). The hookup end of the irrigation pipe will be at one of the gable ends, near the ridge. It is helpful to purchase a hose timer so watering can be automated.

Ventilation and Cooling of Greenhouse

Glass greenhouses are effective at heating up quickly on summer days. If you discover your greenhouse is becoming warmer than you desire, here are some options for cooling.

- Shadecloth - Janssens makes an interior shadecloth system
- Exhaust Fan - recommended to be installed in the gable of the greenhouse to blow out the hottest air. Replace a glass pane with a lexan panel into which you can mount the fan. Many exhaust fans will use an external thermostat to control at what temperature it turns on and off. Place the exhaust fan opposite your louver window to create a cross breeze. For the most

effective cross breeze, it is often recommended to close window vents to force airflow through your louver window.

- Misting System - in dry environments, a misting system turning on at the hottest point of the day can cool a greenhouse up to 15 degrees.
- Tinting - Aftermarket tinting may be applied to the glass panes
- Whitewash - available from some greenhouse retailers, this can be washed off when the hot season is over.
- Exterior shade cloth - an exterior shade cloth, though not as beautiful, can be highly effective. An aluminet shade cloth is a metallic woven shade cloth that goes up and over the outside of the greenhouse. The metallic surface reflects the heat of the sun's rays before they get inside the greenhouse, while also providing shade.

Heating the greenhouse

Although the greenhouse heats up quickly during sunny days, you will likely find you will need to provide supplemental heat during cold winter nights and cold cloudy days.

- Heaters - electrical, propane and wood stoves have all been used. Be sure to properly vent according to manufacturer instructions. Find a BTU calculator online to determine how powerful a heater you need. This is based on a variety of factors including greenhouse material, size, location/climate, low temperatures and desired goal temperature.
- Heat Sink - The more mass you have inside your greenhouse, the more heat can be absorbed during the warm day to release at night. This can help mitigate huge temperature swings during light frost, but can also reduce your heating costs. Easy ways to add mass that can retain heat are raised beds, a large dark water tank, or organic material. There is much information online about planning/designing more in depth heat sinks in your greenhouse - including flooring choices.
- Resources on insulated floors and geothermal heat can be found on many garden blogs.

Can I Use My Greenhouse as an Additional Living Space?

- These structures are designed to be a greenhouse first and foremost. As packaged, the greenhouse is not designed to be water/air tight. Greenhouse plants do benefit from a turn of air. You will need to do some extra sealing with silicone on the roof around the glass to achieve watertightness.
- We recommend any furniture be indoor/outdoor and that fine wood furniture/electronics be avoided or sufficiently protected.
- The glass is single pane, so there is a good chance for condensation on the inside that might drip. The roof windows do have auto openers, so it is likely the roof vents will be open during a rainstorm if the temperature in the greenhouse is above 68 degrees. You can switch to all manual openers if preferred.
- On sunny days, glass greenhouses can get warm very quickly. Depending on your climate, you will likely be fighting the heat in the summer (late spring/early fall).

It has been done, but you will need to make customized adjustments such as extra sealing, climate control, window tinting and heating. Indoor/outdoor furnishings are strongly recommended. Exaco will not be held responsible for any damages.

Maintenance of Greenhouse

The following will help keep your greenhouse in tip top shape:

- **WINTER/SNOW/ICE CONSIDERATIONS:**
 - The roof will need to be cleared of snow, this removes weight from the roof and also allows the sun to shine in and heat your greenhouse
 - Heating your greenhouse may also help some of the snow melt/slide off to assist in keeping the roof clear. If you are heating the greenhouse, you may wish to disengage your pistons so the roof vents do not open.
 - If you are expecting heavy snowfall that you will not be able to clear in a timely manner, we recommend bracing your ridge beam with a 2x4 in the center to help support the weight. Snow should still be cleared as soon as it is possible.
 - If you are in an area that routinely gets significant snow there are some options to strengthen and support your greenhouse:
 - Install self-tapping screws in addition to the bolts where the rafters meet the ridge beam and the gutters (noted in assembly manual).
 - Purchase extra spandrels/snow supports for your greenhouse for the ridge and gutters.
 - Add a stainless steel cable with a turnbuckle connecting opposite sidewalls/spandrels to prevent the sidewalls from bowing out if there is excessive weight on the roof.
- Pistons and openers - Several times each year oil your piston rods, threading, and moving parts of your openers. You may use WD40 or even olive oil. If your pistons stop opening your windows, you likely need to oil them to loosen them up.
- Glass Maintenance
 - Cleaning Glass - use a gentle cleaner, such as Palmolive dish soap with a soft cloth. A squeegee with a long handle is helpful as well. Distilled white vinegar can be used to remove hard water spotting.
 - Replacement Glass - if you need to replace a piece of broken glass, please refer to the glass spec sheet in this manual. Replacement panes of 3/16" standard tempered safety glass should be ordered from a local glass shop. Exaco will not ship large pieces of glass, locally ordered replacement panes of standard tempered safety glass will match the original panes.
- Polycarbonate Cleaning - use a gentle cleaner, such as Palmolive dish soap with a soft cloth.

Questions? Need Assembly Support?

Please call Exaco at 877-760-8500 or email customerservice@exaco.com.

Royal Victorian Foundation - Exterior Dimensions

	A	X	B
VI 23	93 inches (2360mm)		122 inches (3098mm)
VI 34	122 inches (3098mm)		180 inches (4574mm)
VI 36	122 inches (3098mm)		238.2 inches (6050mm)
VI 46	151 inches (3836mm)		238.2 inches (6050mm)

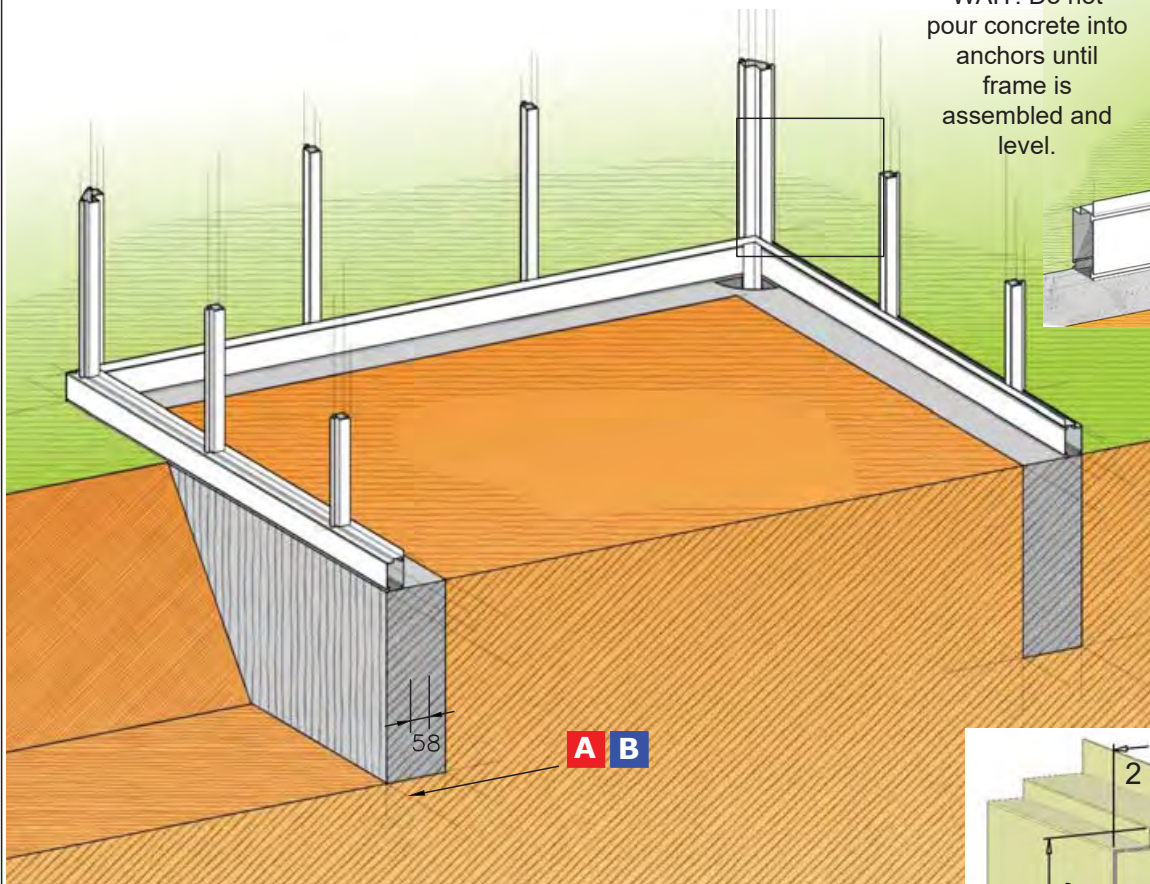
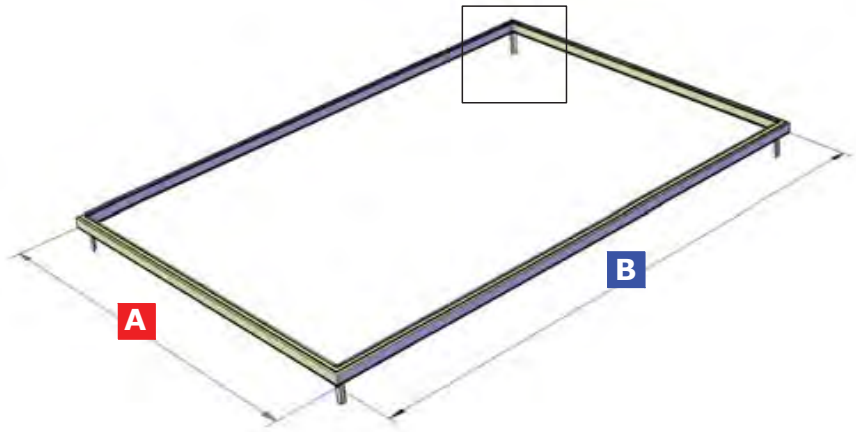

WAIT! Do not pour concrete into anchors until frame is assembled and level.

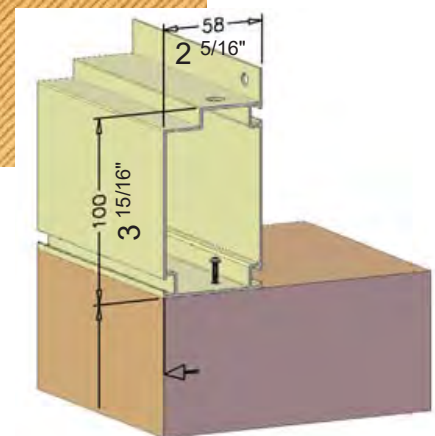
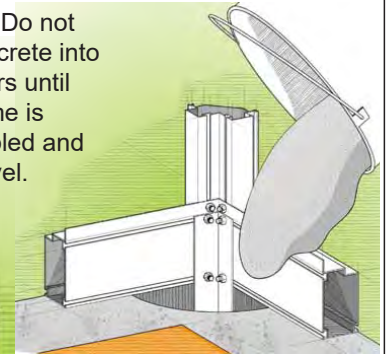

IMPORTANT NOTES FOR PREPARING YOUR SITE:

- Do not set anchors in concrete until the entire greenhouse frame is complete, level and square. You will need some play to attach the uprights.
- It is recommended to build your foundation down to the frost line in your area and/or consult a local contractor for recommendations.
- Greenhouse base frame is 2.25" wide
- Corner anchor posts are 1.5" x 1.5". They attach at the interior corners of the base frame, then extend 12" below ground. Bolts attach to the bottom of the anchor to be a "catch" in the concrete. We recommend leaving a 4 to 6" hole in your concrete for the anchor. Do not embed the corner anchors into concrete until the greenhouse structure is built, leveled and square.
- Embedding the corner anchor into concrete is the most secure method, although you may choose to trim them off, cut in half, and use as L brackets to attach to the greenhouse and foundation with the appropriate stainless steel screws (i.e. Tap Con screws for concrete)

OPTION: Building a stem wall for your greenhouse

(Door extension kit is required)

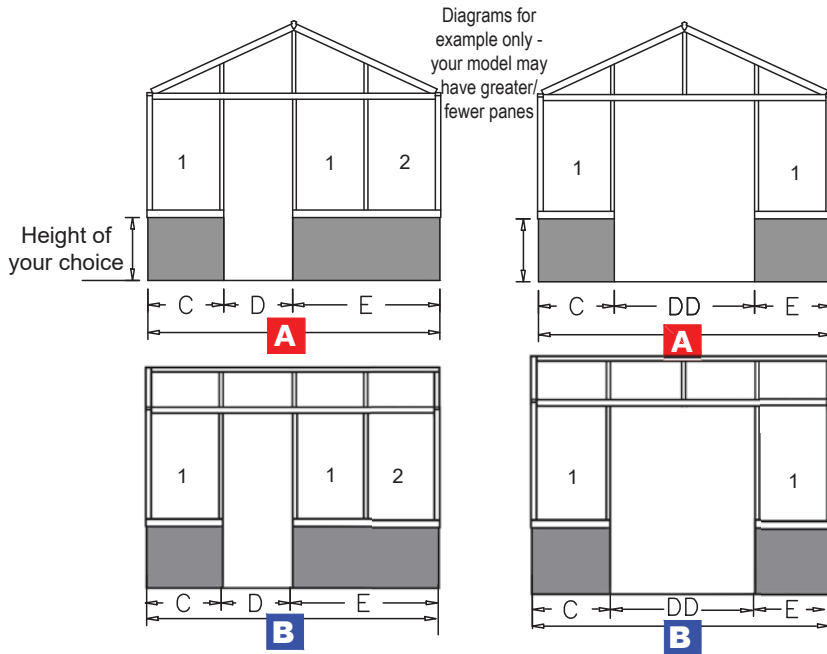

DOUBLE CHECK YOUR MEASUREMENTS:

A OR B = C + D(OR DD) + E!!!!

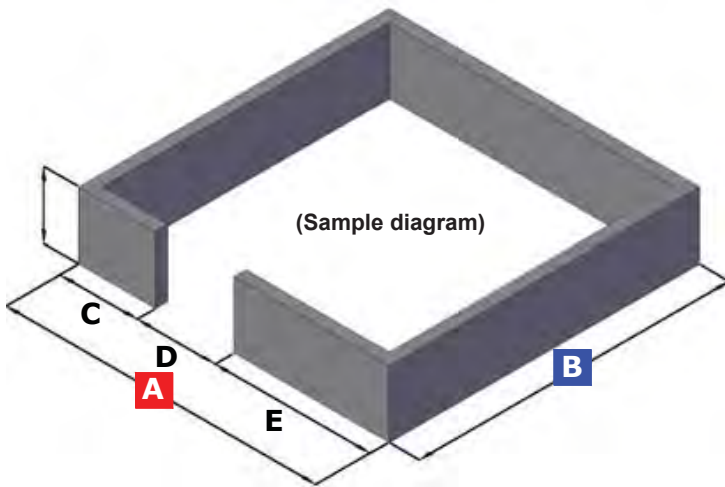

- A** = Gable end length if placing door on gable
- B** = Side length if placing door on long side
- C** = Measurement to left of door based on # of glass panes - see diagrams in intro for your greenhouse if unsure
- D** = Rough opening for SINGLE door
- DD** = Rough opening for DOUBLE door
- E** = Measurement to right of door based on # glass panes

Measurements are in millimeters for precision. Please use combination tape measure in your kit.

- A** (gable) = 2360 | 3098 | 3836
- B** (side) = 2360 | 3098 | 3836
4574 | 5312 | 6050
- C** = 1 pane = 829
2 panes = 1567
3 panes = 2305
4 panes = 3043
- D** = 703 (**DD** = 1441)
- E** = 1 pane = 829
2 panes = 1567
3 panes = 2305
4 panes = 3043

A OR B = C + D(D) + E !!!

Notes about stem walls:

- Read notes on previous and following pages to understand anchoring options, and measurements of frame for thickness of your wall.
- Your doorway may be placed on the gable end or long side.
- Stemwall height is determined by you, maximum height with standard kit is 30".
- All measurements are external dimensions of the aluminum profiles.

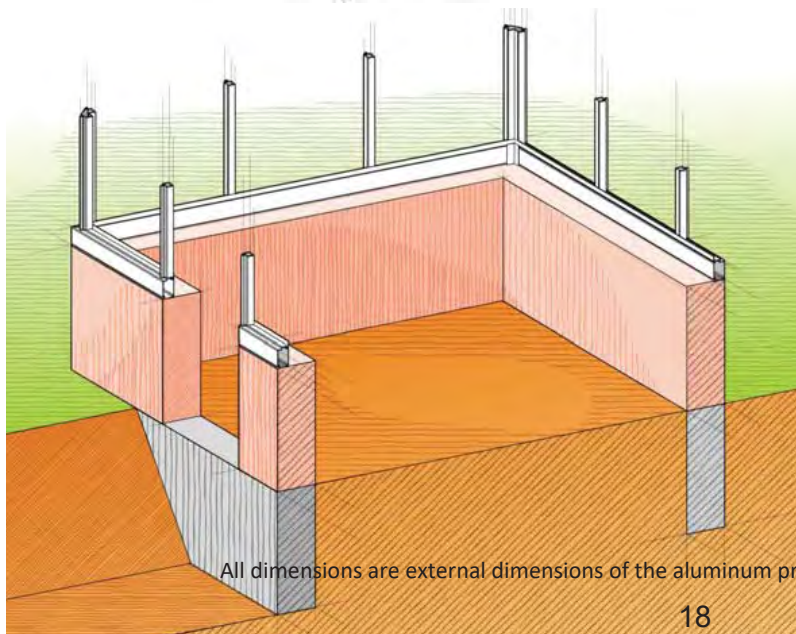

Sliding door extension installation

Can be installed on long or short gable end of greenhouse

(Single)

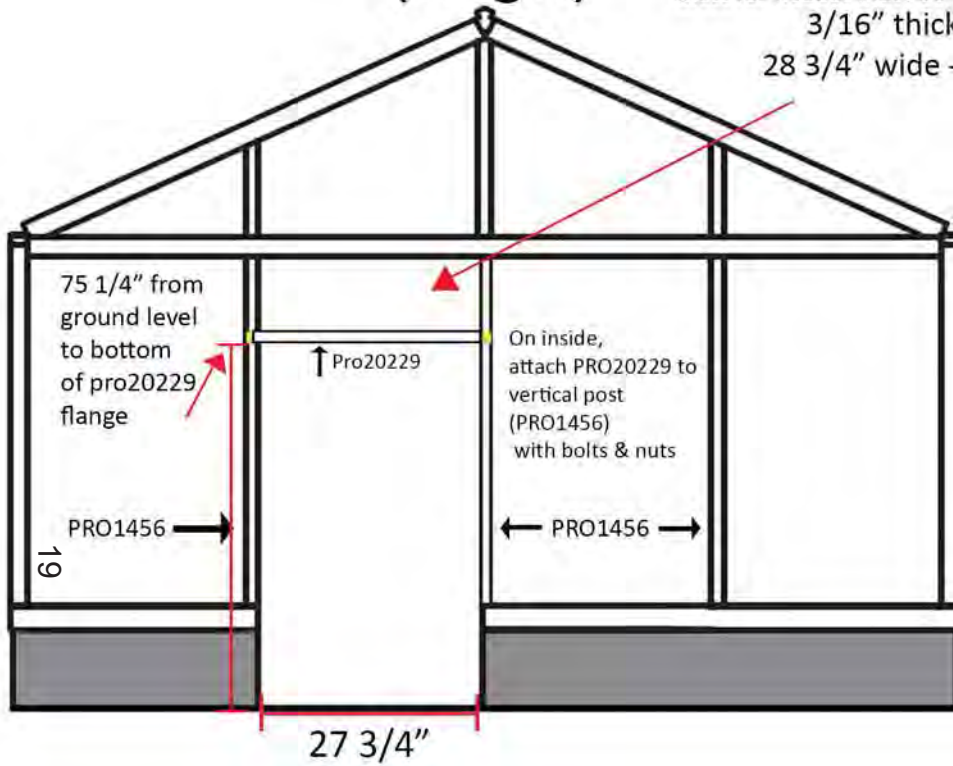

Glass for header must be ordered locally due to custom wall height
3/16" thick tempered safety glass
28 3/4" wide -height determined by wall

(Double)

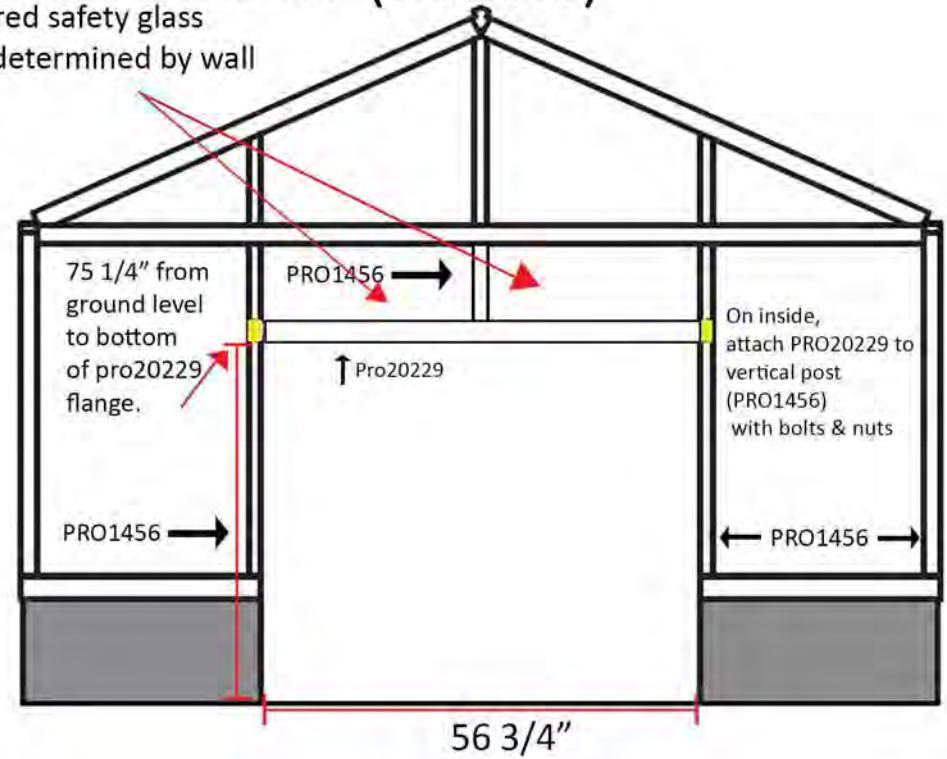

-Opening will be 27 3/4" wide

Kit will include:

- (1) Pro20229 w/ flanges
- Nuts & Bolts

-Opening will be 56 3/4" wide

Kit will include:

- (1) Pro20229 w/ flanges
- (1) 30" Pro1456 (cut to match the height of stem wall)
- Nuts & Bolts

After the doorway is framed out - move to manual for door assembly & installation

Hinged door extension installation - View from inside Greenhouse

Can be installed on long or short gable end of greenhouse
(see door considerations for VI36/VI46 at front of manual)

(Single)

Glass for header must be ordered locally due to custom wall height
3/16" thick tempered safety glass
28 3/4" wide -height determined by wall

(Double)

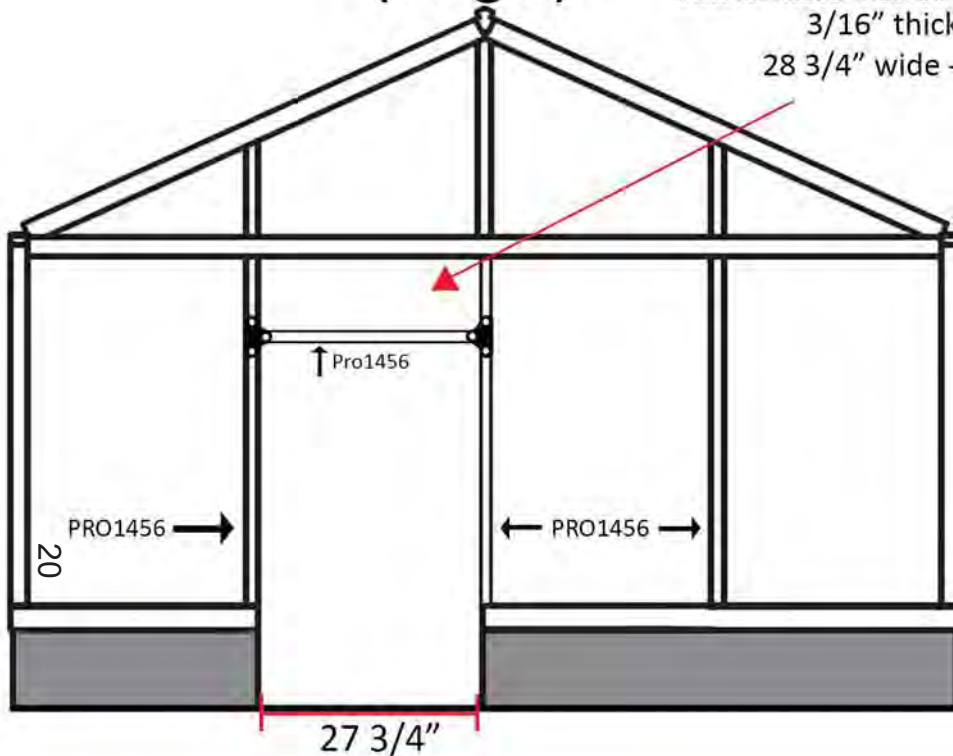

-Opening will be $27 \frac{3}{4}''$ or 703 mm wide

Kit will include:

- (1) PRO1456
- (2) 3-Hole Brackets
- Nuts & Bolts

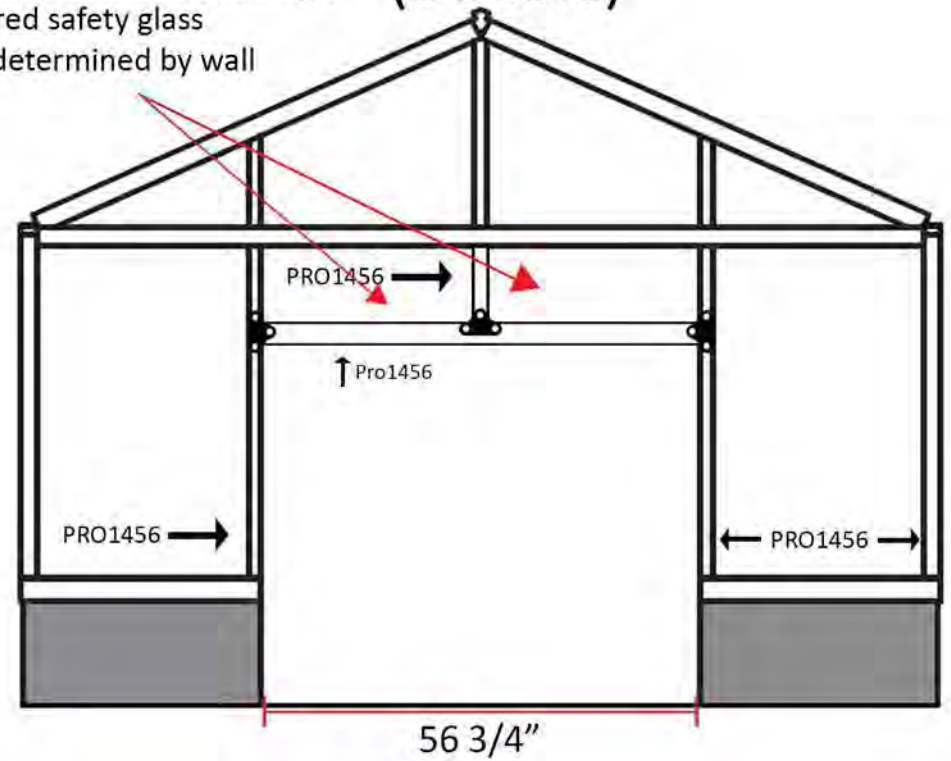

-Opening will be $56 \frac{3}{4}''$ or 1441 mm wide

Kit will include:

- (1) PRO1456
- (1) 30" Pro1456 (cut to match the height of stem wall)
- (3) 3-Hole Brackets
- Nuts & Bolts

Hinged door will include its own door jamb - place the horizontal PRO1456 on top of the door jamb.
move to manual for door assembly & installation

PALLET Royal Victorian

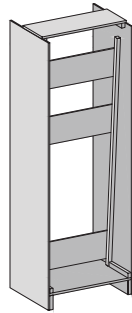















WEIGHT:	MASTER
VI23	384 kg
VI24	485 kg
VI34	567 kg
VI36	676 kg
VI46	630 kg + 170 kg

DIMENSIONS:
800 x 900 x 2300 mm

NOTE: This is the packing list for the standard kit for the Royal Victorian greenhouses. If you have added optional accessories, they will not be on this list.

Identify parts by extrusion shape (cross section) and length. We strongly recommend using a metric or combination tape measure. Measurements are kept in metric for precision.

Be aware items are packed in front of the glass as well as in the cubby behind the glass.

ITEM	VI23	VI24	VI34	VI36	VI46			
 Louvered window (Black)	1 pc	1 pc	1 pc	1 pc	1 pc			
 Sliding door (ESD_183_ZS)	1 pc	1 pc	1 pc	2 pc	2 pc			
 Roof Window (DAKR_HEL)	2 pc	3 pc	3 pc	4 pc	6 pc			
 PRO6578 corner profile	1830 mm	4 pc	4 pc	1830 mm	4 pc	4 pc	1830 mm	4 pc
 PRO1456 glazing bar wall	1830 mm	10 pc	14 pc	1830 mm	16 pc	20 pc	1830 mm	22 pc
 PRO6918 endbar roof	1230 mm	4 pc	4 pc	1630 mm	4 pc	4 pc	1986 mm	4 pc
 PRO1456 glazing bar roof	1230 mm	6 pc	10 pc	1630 mm	10 pc	14 pc	1986 mm	14 pc
 Gutter downspout (PRO10980 tube Ø40)	1900 mm	2 pc	2 pc	1900 mm	2 pc	2 pc	1900 mm	2 pc
 PRO21214 wind bracing wall	1975 mm	8 pc	8 pc	1975 mm	8 pc	8 pc	1975 mm	8 pc
 PRO1748 rubber 12m/rol	5 pc	6 pc	7 pc	8 pc	9 pc			
 Mixed Hardware (ZAK_H): Screw 4.8x38mm (for gutter elbow) 2 pc Bolt M6x25mm (for roof wind braces) 4 pc Screw 4.8x19mm (roof wind braces/finals) 10 pc	1 pc	1 pc	1 pc	1 pc	1 pc			
Glassholder (PRO20780)	32 pc							
Gutter Elbow PVC Ø40 90° PVC	2 pc							
Black Gutter inserts	2 + 2 pc							
 BAG_GLASS SPACERS red spacers/shims silicone	1 pc	1 pc	1 pc	1 pc	1 pc			
 RIDGE DECORATION box	1 pc	1+1 pc	1+1 pc	2+1 pc	2 + 1 pc			
 SPANDREL (Deco Scroll Support)				3 pc	3 pc			
VI46 Additional Nuts/Bolts (ZAK_BOUT): nut cap M6 50 pc nut M6 50 pc bolt M6x12 50 pc					1 pc			

Main kit of nuts and bolts will be in Colli B - see notes

POSITION	GLASS DIMENSIONS	VI23	VI24	VI34	VI36	VI46
sliding door	730 x 1850 mm (28 3/4" x 72 3/4")	1 pc	1 pc	1 pc	2 pc	2 pc
walls	730 x 1850 mm (28 3/4" x 72 3/4")	12 pc	16 pc	18 pc	21 pc	23 pc
under louvre-vent	730 x 825 mm (28 3/4" x 32 1/2")	1 pc	1 pc	1 pc	1 pc	1 pc
triangle H1	1099 x 74 x 543 mm	4 pc	4 pc	-	-	-
triangle H2	730 x 74 x 411 mm	-	-	4 pc	4 pc	-
triangle H3	730 x 414 x 696 mm (113 plat)	-	-	4 pc	4 pc	-
triangle H4	730 x 72 x 357 mm	-	-	-	-	4 pc
triangle H5	730 x 360 x 645 mm	-	-	-	-	4 pc
triangle H6	361 x 648 x 737 mm (133 plat)	-	-	-	-	4 pc
roof	730 x 1250 mm (28 3/4" x 49 3/16")	6 pc	9 pc	-	-	-
roof	730 x 1650 mm (28 3/4" x 64 7/8")	-	-	9 pc	12 pc	-
roof	730 x 2000 mm (28 3/4" x 78 3/4")	-	-	-	-	10 pc
roofwindow	730 x 825 mm (28 3/4" x 32 1/2")	2 pc	3 pc	3 pc	4 pc	6 pc
under roofwindow	730 x 425 mm (28 3/4" x 16 3/4")	2 pc	3 pc	-	-	-
under roofwindow	730 x 825 mm (28 3/4" x 32 1/2")	-	-	3 pc	4 pc	-
under roofwindow	730 x 1180 mm (28 3/4" x 46 1/4")	-	-	-	-	6 pc

COLLI A (Carton A)

WEIGHT:
 VI23/VI24 19 kg
 VI34/VI36 25 kg
 VI46 29 kg

DIMENSIONS:
 250 x 150 x 2800 mm VI23 / VI24
 3300 mm VI34 / VI36
 4050 mm VI46

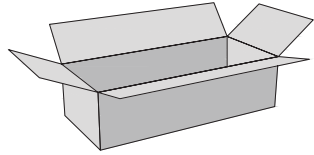







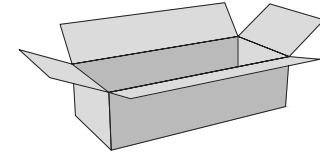









COLLI B (Carton B)

WEIGHT:
 M23 26 kg
 M24 / M34 39 kg
 M36 / M46 52 kg

DIMENSIONS:
 250 x 150 x 3200 mm VI23
 4700 mm VI24/VI34
 6250 mm VI36/VI46



ITEM	VI23 / VI24	VI34 / VI36	VI46
 PRO6120 foundation profile	2360 mm 2 pc	3098 mm 2 pc	3836 mm 2 pc
 Roof Diagonal Support B19_1030 (round tube Ø19)		1030 mm 2 pc	1030 mm 2 pc
 Corner Anchors (L40X40GATFUND)	400 mm 4 pc	400 mm 4 pc	400 mm 4 pc
 PRO20229 horizontal gable profile	2244 mm 2 pc	2982 mm 2 pc	3720 mm 2 pc
 PRO21214 wind bracings roof	2543 mm 4pc	2757 mm 4 pc	2980 mm 4 pc
 PRO1456 gable glazing bar	547 mm 2 pc	703 mm 2 pc	736 mm 2 pc
 PRO1456 gable glazing bar 90 / 65		396 mm 2 pc	345 mm 2 pc
 PRO1456 gable glazing bar 90 / 65			634 mm 2 pc
 PRO1456 gable glazing bar 65 / 90		396 mm 2 pc	345 mm 2 pc
 PRO1456 gable glazing bar 65 / 90			634 mm 2 pc
 E400330 halfmoon glazing rubber gasket	1 pc	20 lm 1 pc	20 lm 1 pc
 Mixed Hardware (SAPAKHELIOS): <i>Small Black PVC gable pieces 4+4+2 pc</i> <i>Corner Anchor Bolts M6x50 16 pc</i> <i>Corner Anchor Nut M6 16 pc</i> <i>Gable L brackets (L2G) 10 pc</i>	1 pc	1 pc	1 pc

ITEM	VI23	VI24 / VI34	VI36 / VI46
 PRO6120 foundation profile	3098 mm 2 pc	4574 mm 2 pc	6050 mm 2 pc
 PRO20227 gutter profile	3098 mm 2 pc	4574 mm 2 pc	6050 mm 2 pc
 PRO6760 ridge profile	3098 mm 1 pc	4574 mm 1 pc	6050 mm 1 pc
 Assembly Bolts/Nuts (ZAK_BOUT) <i>nut cap M6 50 pc</i> <i>nut M6 50 pc</i> <i>bolt M6x12 DIN933 A2 50 pc</i>	2 pc	3 pc	3 pc
 Additional VI 46 Corner Anchors (L40X40GATFUND)			400 mm 2 pc



IMPORTANT!!! The packages of nuts/bolts/covers are tucked **INSIDE** the gutter profiles (PRO20227). You must cut off all shrink wrap on gutters to find them.

Royal Victorian Glass Sizes - 4mm thick (3/16")

(VI23 7'9"x10'2")

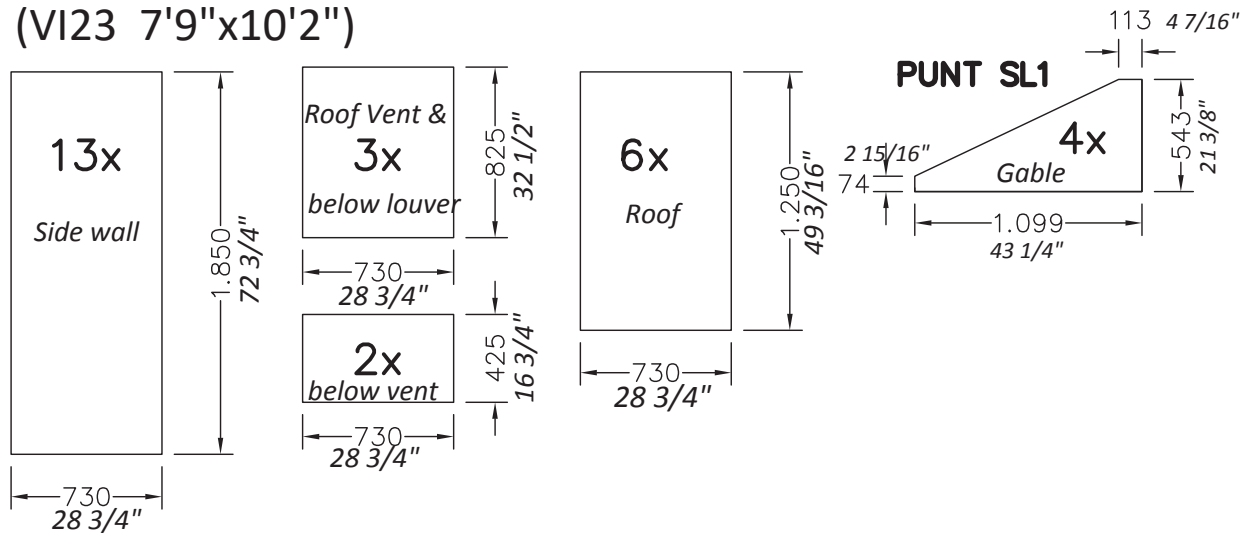

(VI34 10'2" x 15')

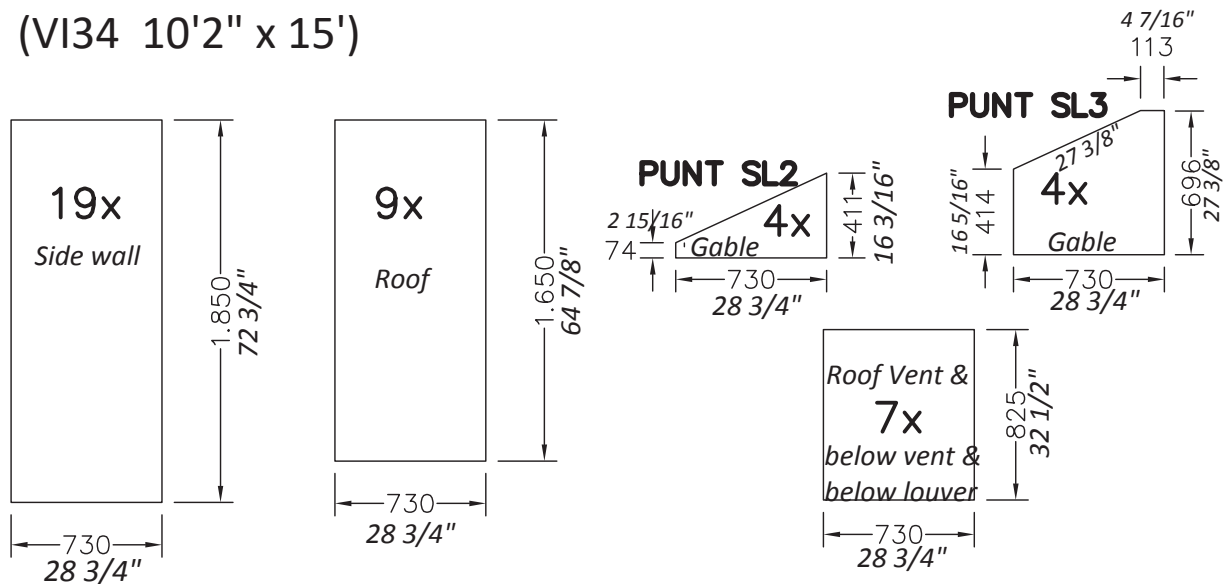



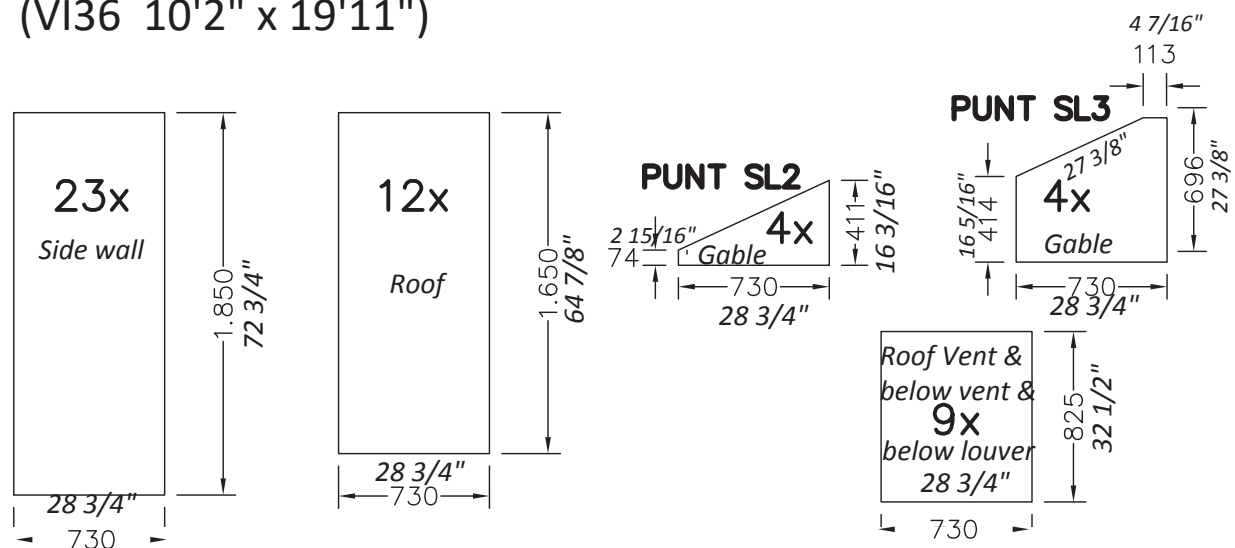



(VI36 10'2" x 19'11")

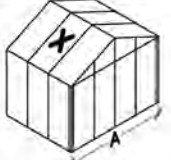

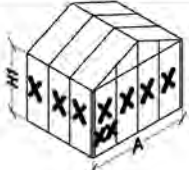
VI46 Glass

3/16" (4mm) tempered safety glass

	<p>Full Roof Pane x 10 A=384cm: 730 x 2.000 28 3/4" x 78 3/4"</p>
	<p>Roof Vent Pane x 6 730 x 825 28 3/4" x 32 1/2"</p>
	<p>Glazing Under Roof Vent x 6 A=384cm: 730 x 1.175 28 3/4" x 46 1/4"</p>
	<p>Side Wall Glazing x 22 H1=201cm: 730 x 1.850 28 3/4" x 72 3/4"</p>
	<p>Sliding Glass Door x 2 H1=201cm: 730 x 1.850 28 3/4" x 72 3/4"</p>
	<p>Top Hang Window (optional) 570 x 865</p>
	<p>Glass Below Top Hang Window/Louver 730 x 825 x 1</p>

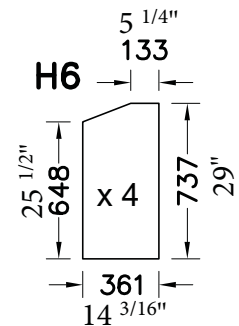
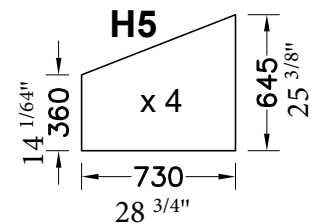
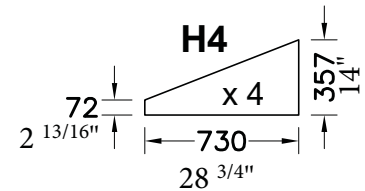
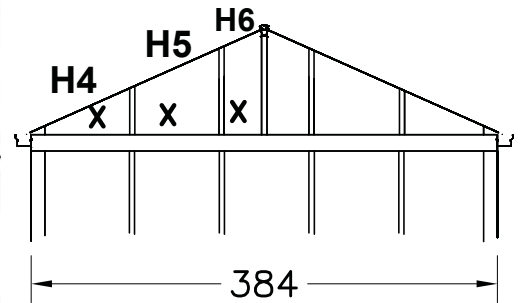

Key to Profile (Extrusion) Placement

Note: Model pictured in entire manual is VI34 - your size/layout may vary.

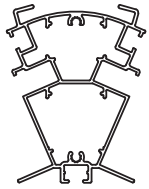

Ridge Beam

PRO6760

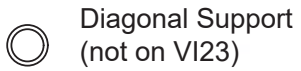

Diagonal Support
(not on VI23)

Ø 19



Horizontal
Gable
Profile

PRO20229

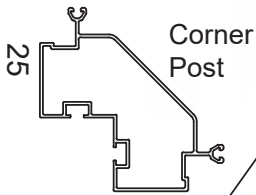

Corner
Post

PRO6578



Vertical
Glazing
Bar

PRO1456

Wind
Brace/Strap

TRE

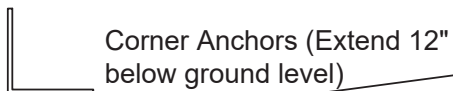

Corner Anchors (Extend 12"
below ground level)

PRO210



Roof
Glazing
Bar

PRO1456

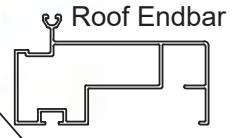

Roof Endbar

PRO6918

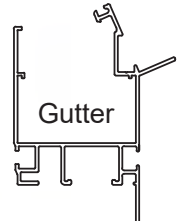

Gutter

PRO20227

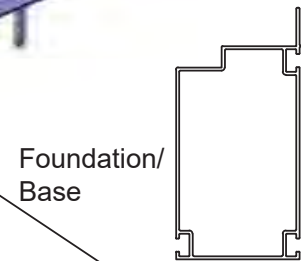

Foundation/
Base

PRO6120

VI36 and VI46 Special Note:

These models include an additional pair of corner anchors at midpoint of 20' wall

HELIOS

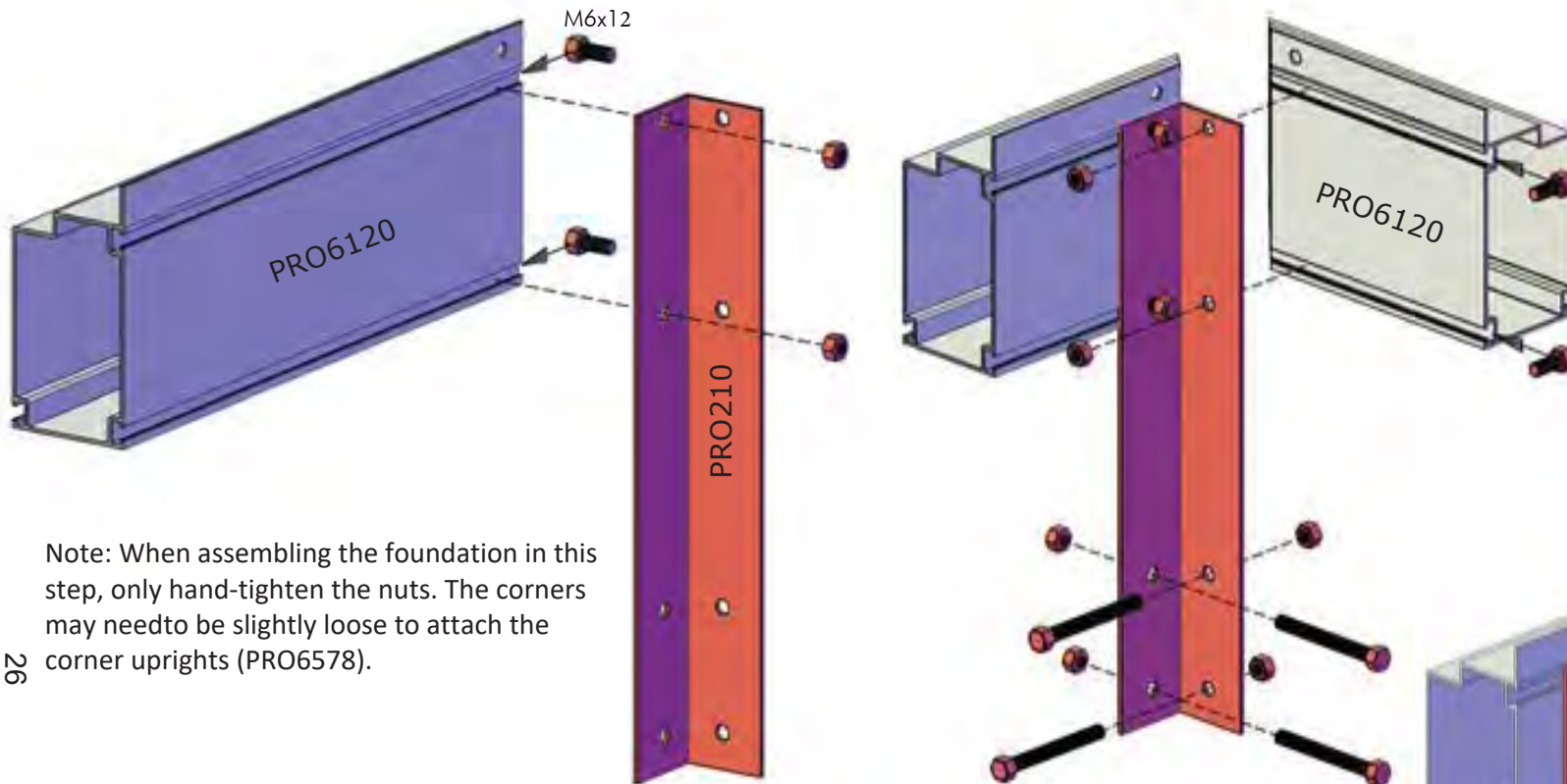

IMPORTANT!
 Before attaching, insert 3 M6x12 bolts as shown for the sliding door guide. You will use 6 bolts for a double sliding door.

Note: When assembling the foundation in this step, only hand-tighten the nuts. The corners may need to be slightly loose to attach the corner uprights (PRO6578).

26

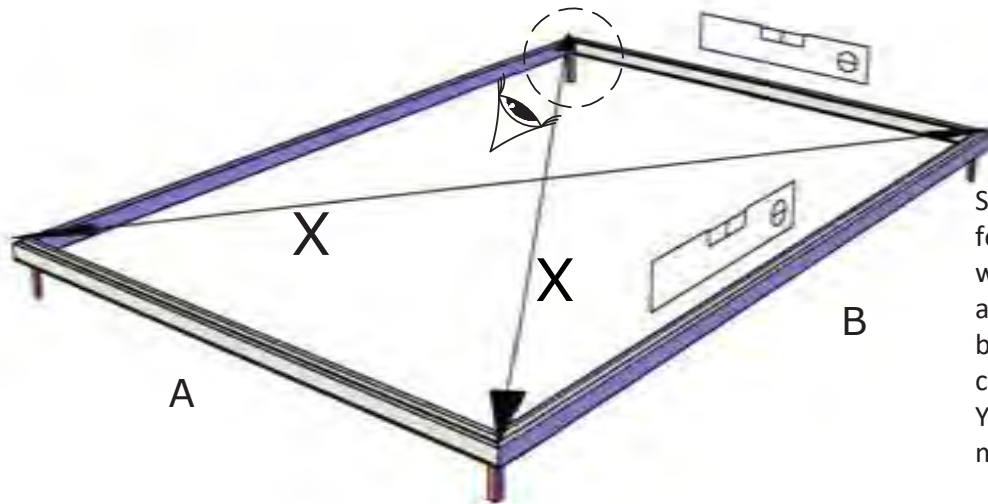

Suggestion: If installed on a concrete foundation you may cut PRO210 flush with the bottom of PRO6120. To anchor, use cut off PRO210 pieces as L-brackets to secure the PRO6120 to the concrete foundation. Please see YouTube animated assembly video for more information.

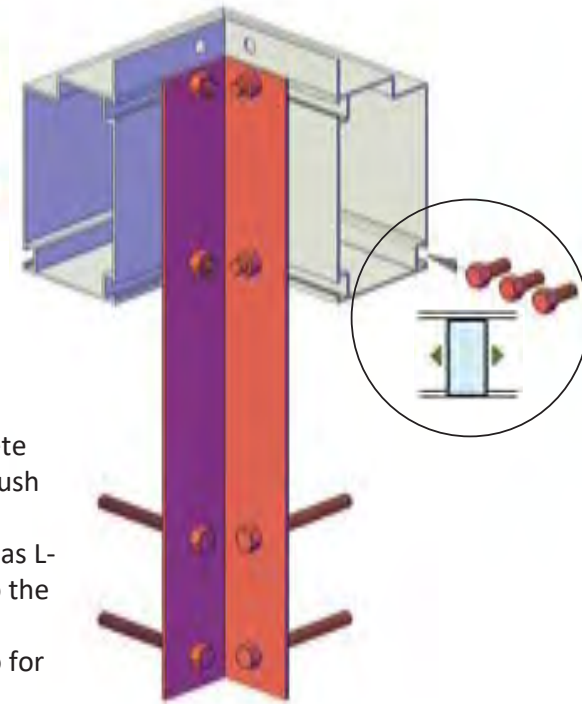

OPTION: **HD** (hinged door)

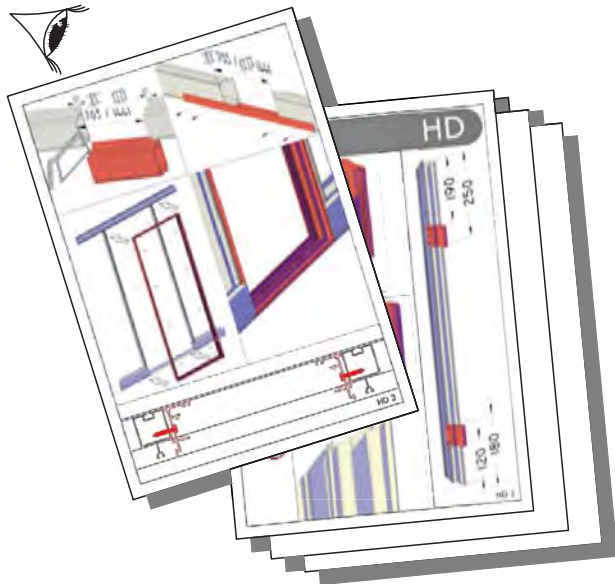
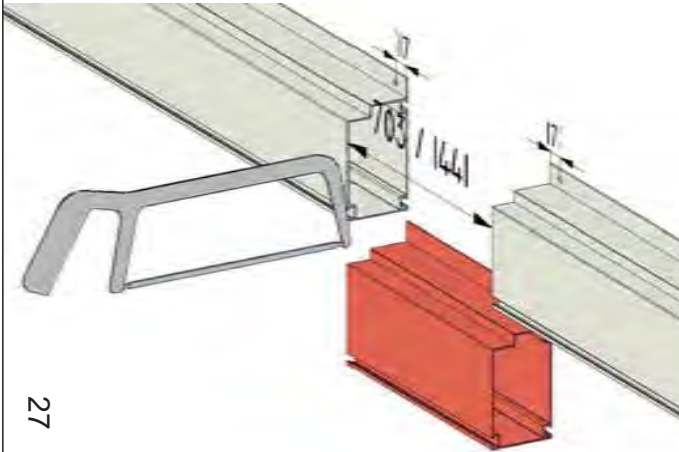
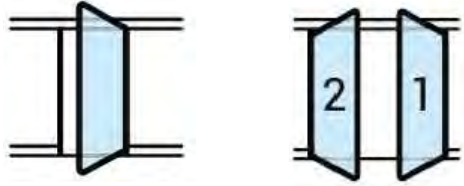

OPTION: **SD** (sliding door)

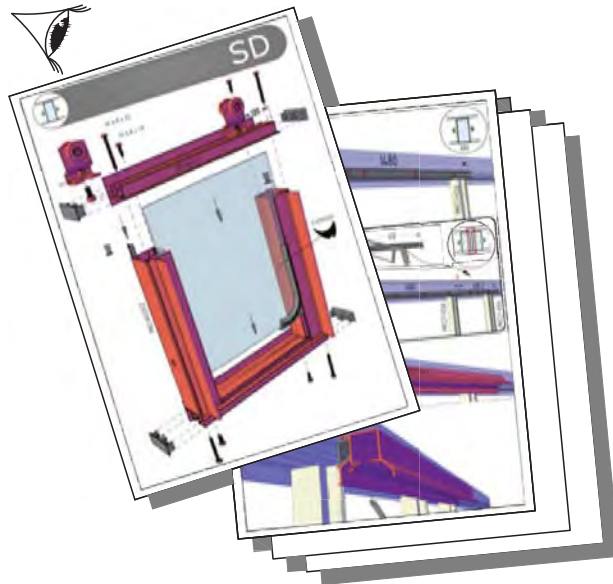
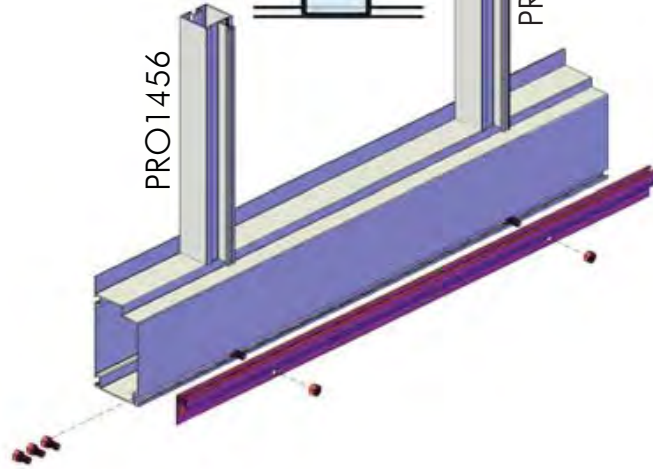

OPTION: **KSD** (low threshold)

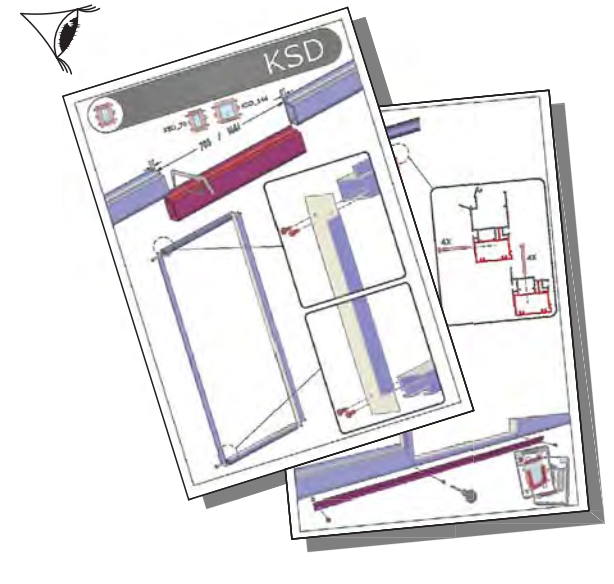
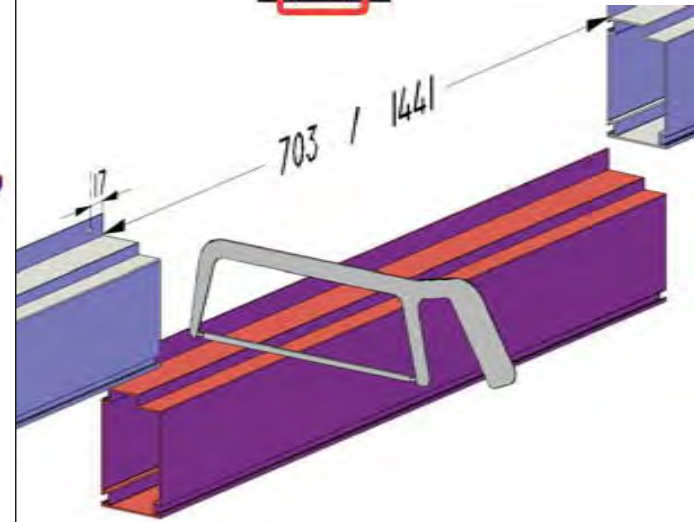
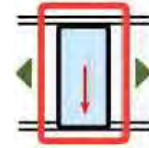

M6x12

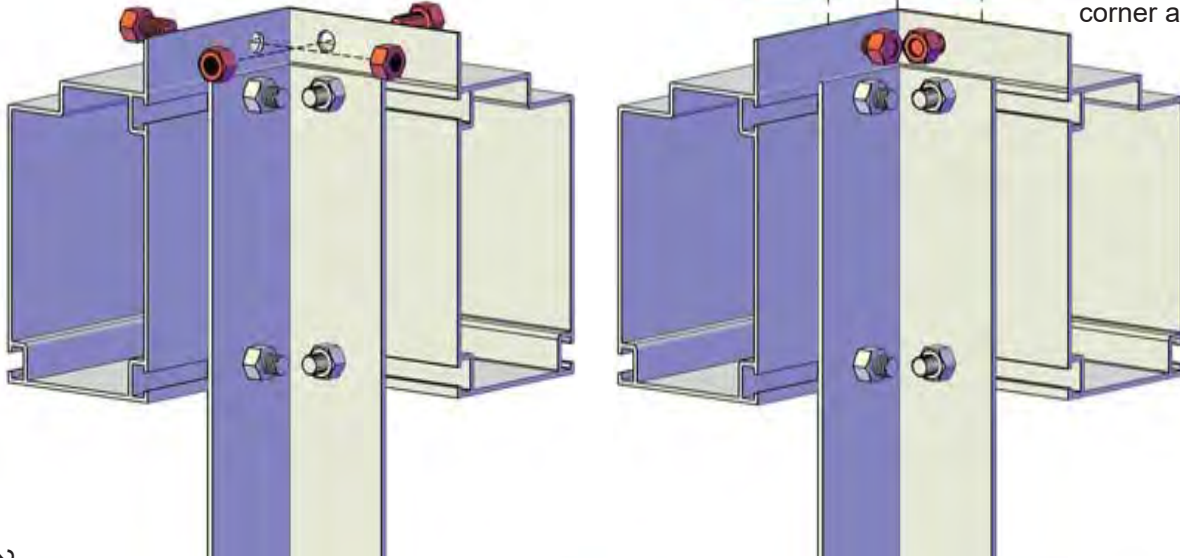

Sliding the corner post (PRO6578) down onto the head of the bolts can be challenging. Use two people: one hold the threaded tips of both bolts with a pliers to position the hexagonal head inline with the channels on PRO6578. It may help to loosen the nuts holding the corner anchor to allow for a little bit of play.

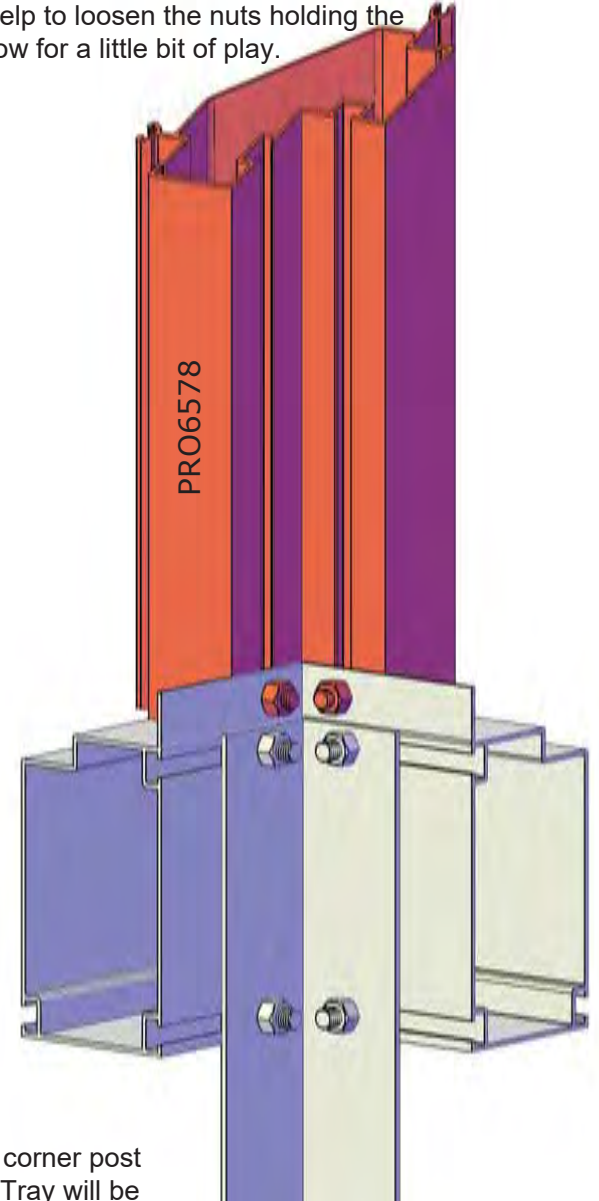

28

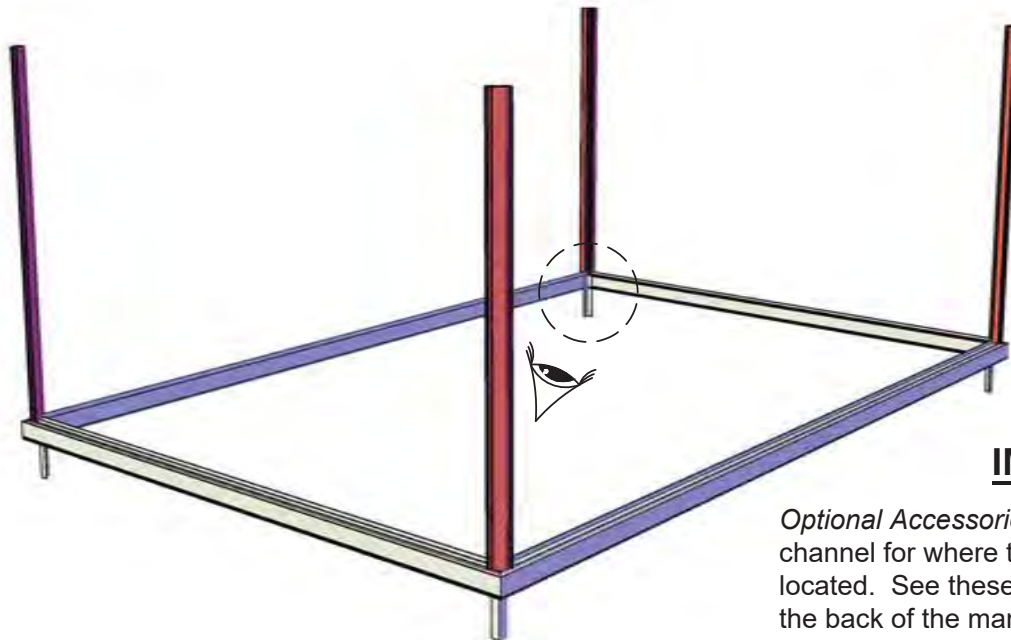

IMPORTANT!

Optional Accessories! Insert a bolt into each corner post channel for where the top shelf and/or Seed Tray will be located. See these pages in the accessories section in the back of the manual.

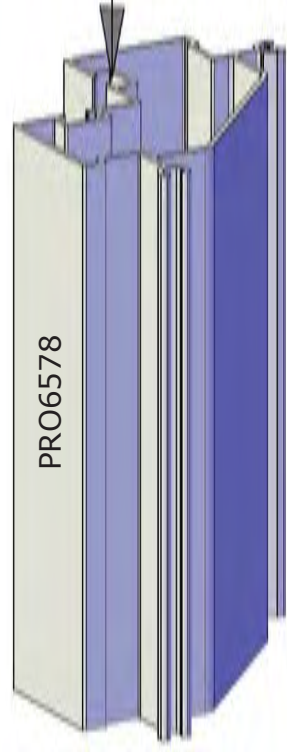
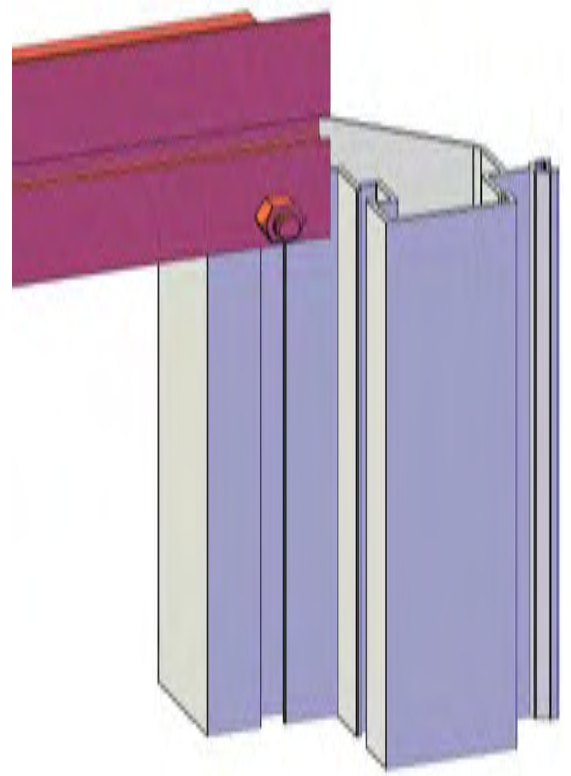
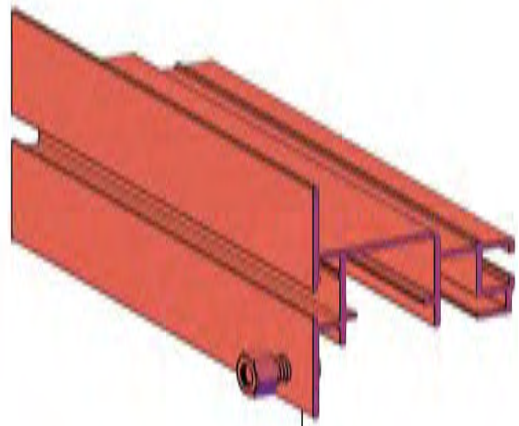
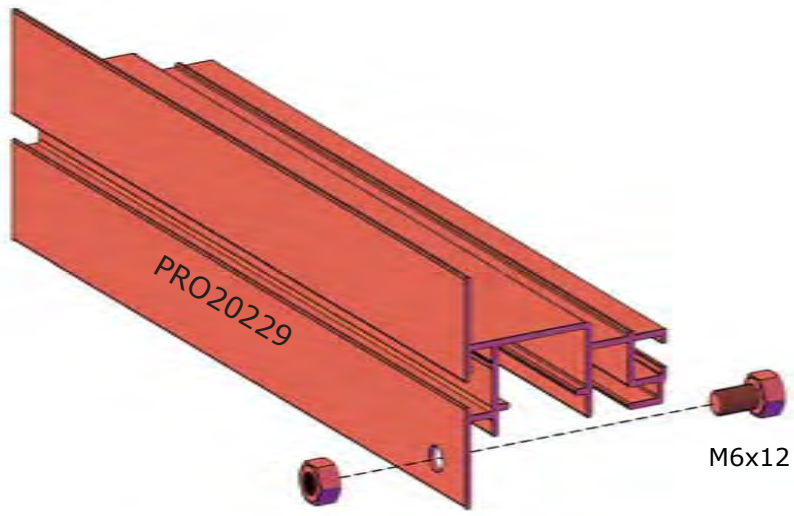

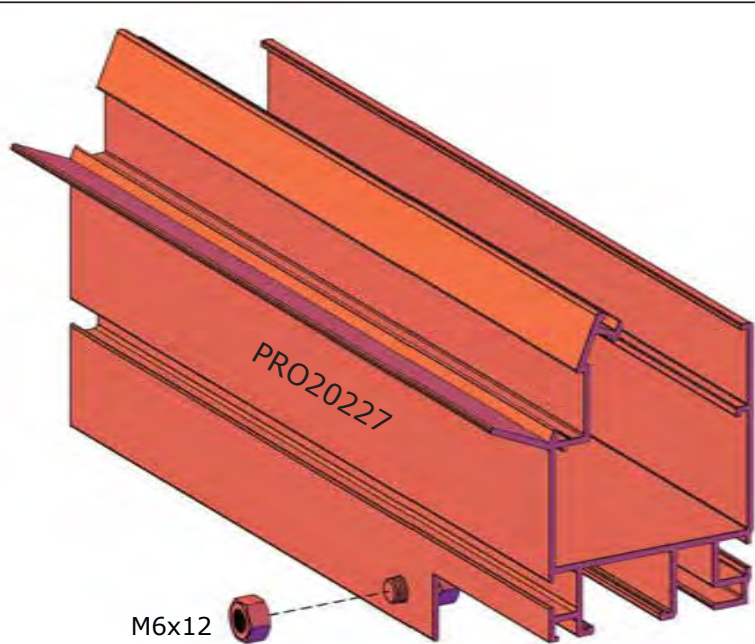

M6x12



30

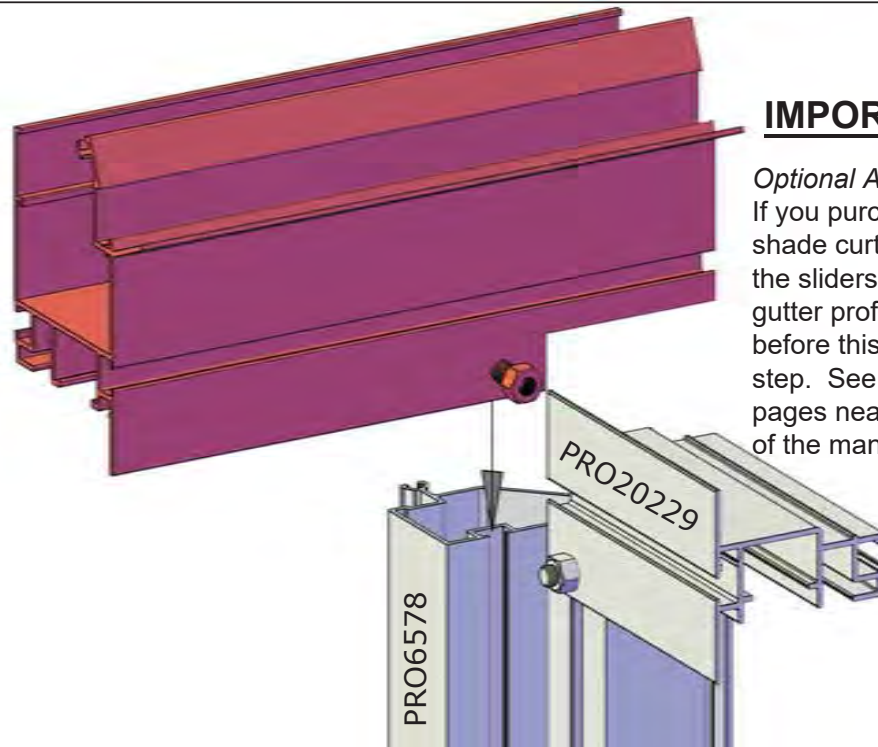

PRO6578

PRO20229

IMPORTANT!

Optional Accessories!
If you purchased shade curtains, insert the sliders into the gutter profile channel before this assembly step. See shade cloth pages near the back of the manual.

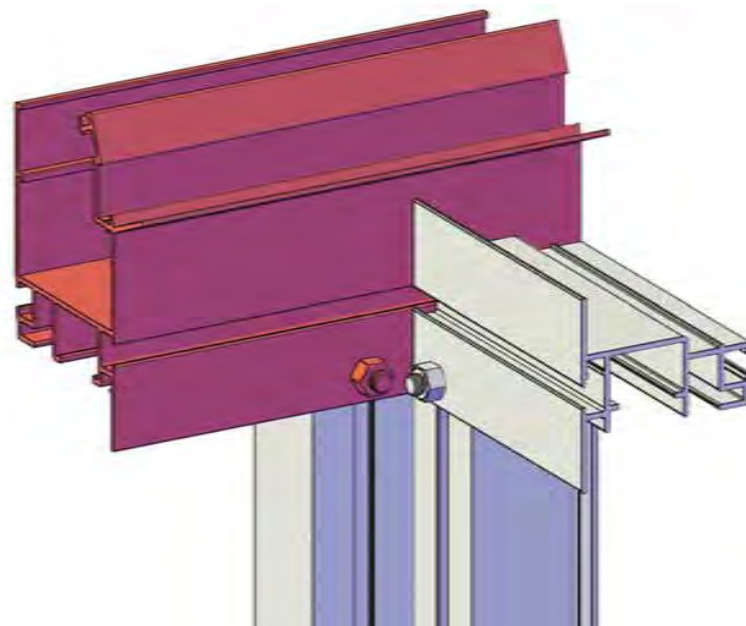

PRO6578

PRO20229

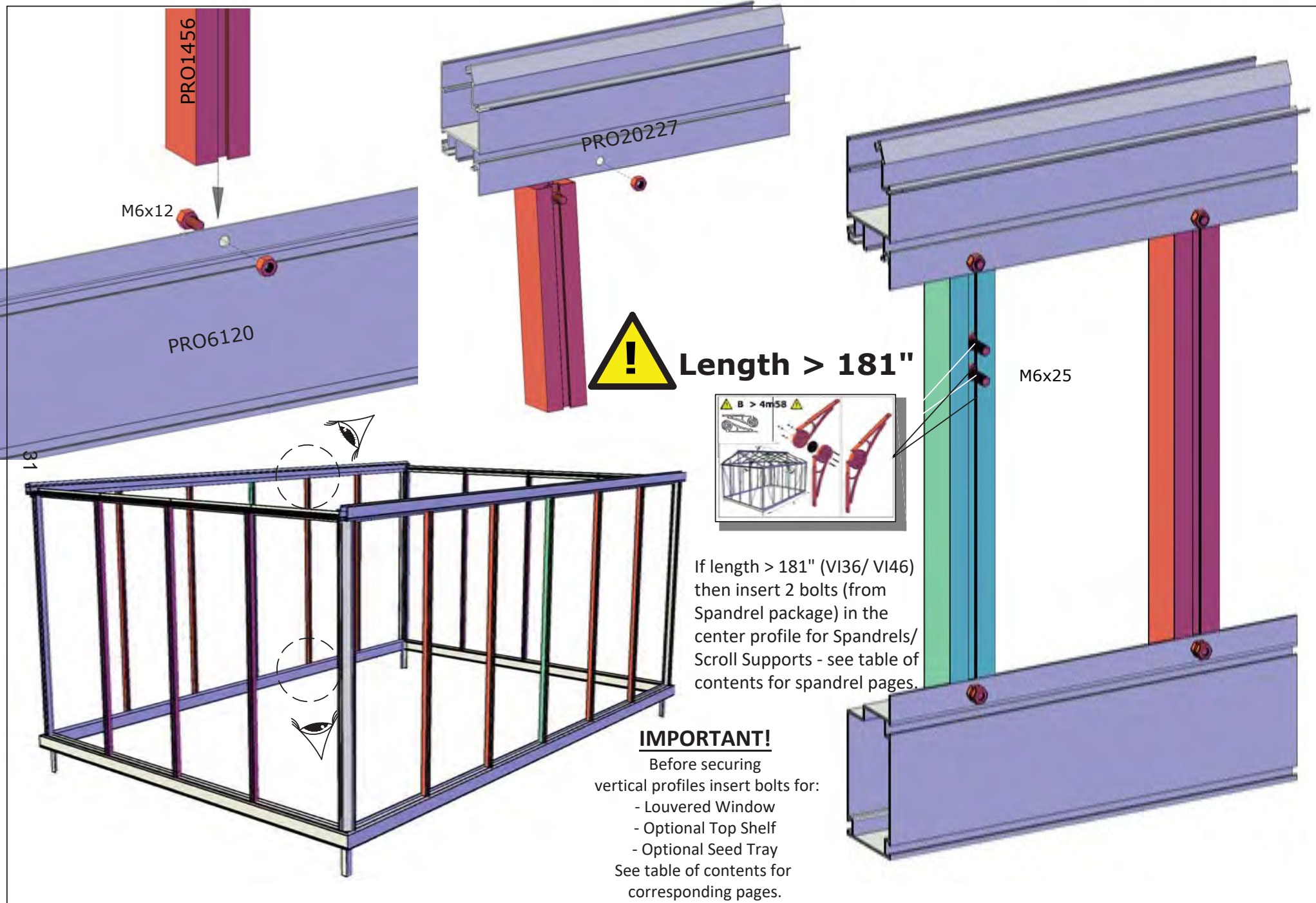

PRO1456

PRO20227

PRO6120

M6x12



Length > 181"

M6x25



If length > 181" (VI36/ VI46) then insert 2 bolts (from Spandrel package) in the center profile for Spandrels/ Scroll Supports - see table of contents for spandrel pages.

IMPORTANT!

Before securing vertical profiles insert bolts for:

- Louvered Window
- Optional Top Shelf
- Optional Seed Tray

See table of contents for corresponding pages.

31

PRO1456

TRE

M6x12

PRO6120

PRO20227

PRO20229

32

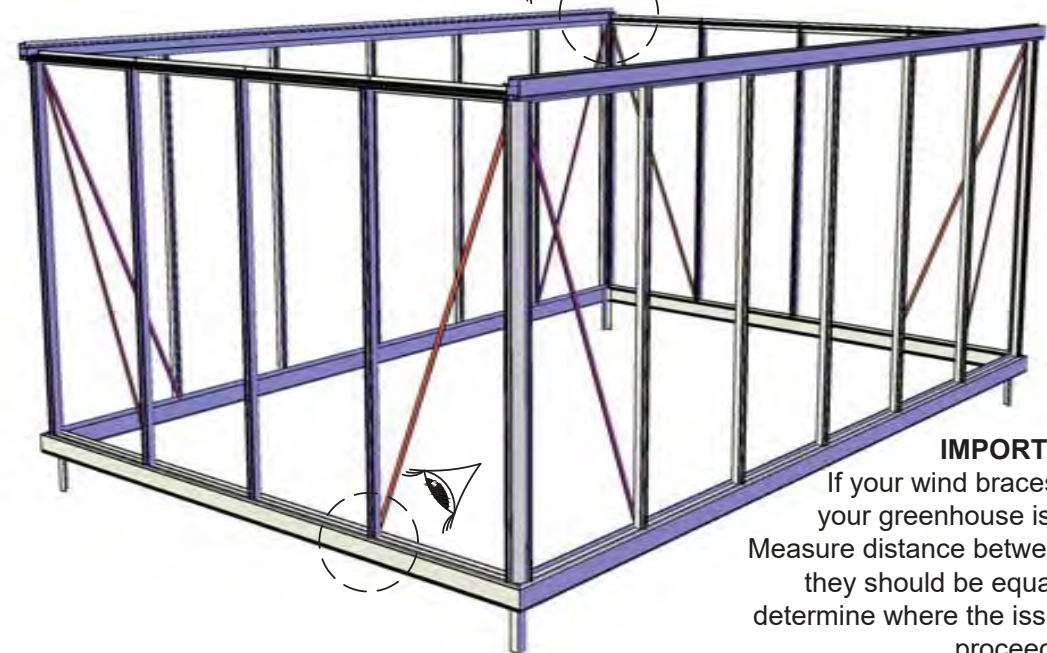

IMPORTANT!

If your wind braces do not reach, your greenhouse is **NOT SQUARE**. Measure distance between diagonal corners - they should be equal. Use a level to determine where the issue lies and fix before proceeding.

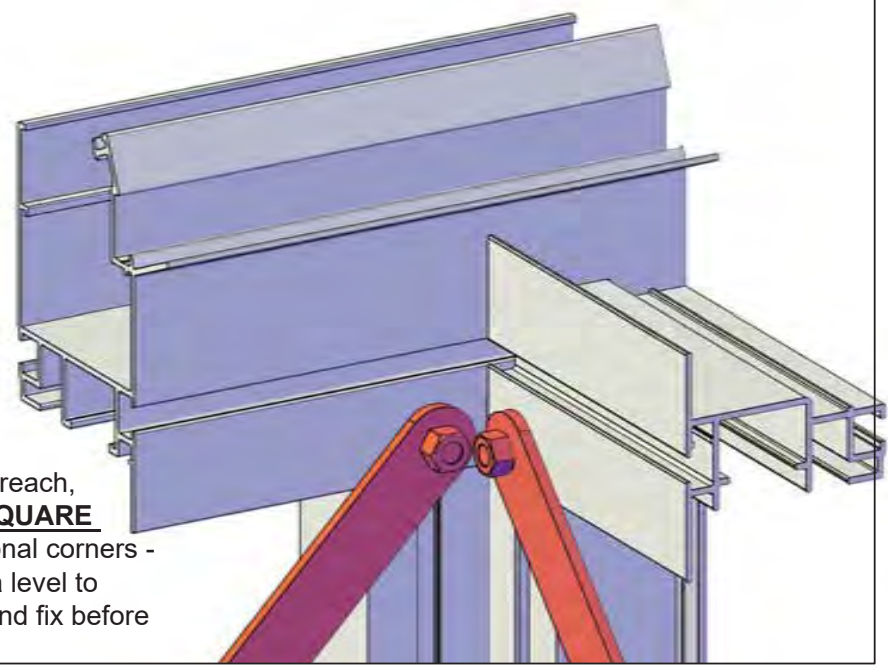

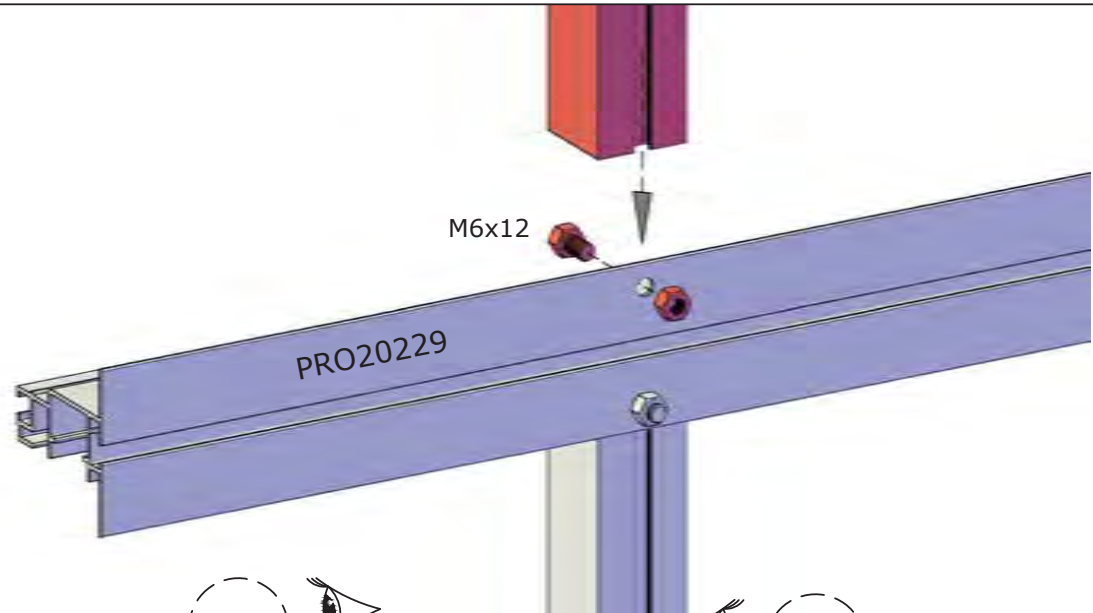

33

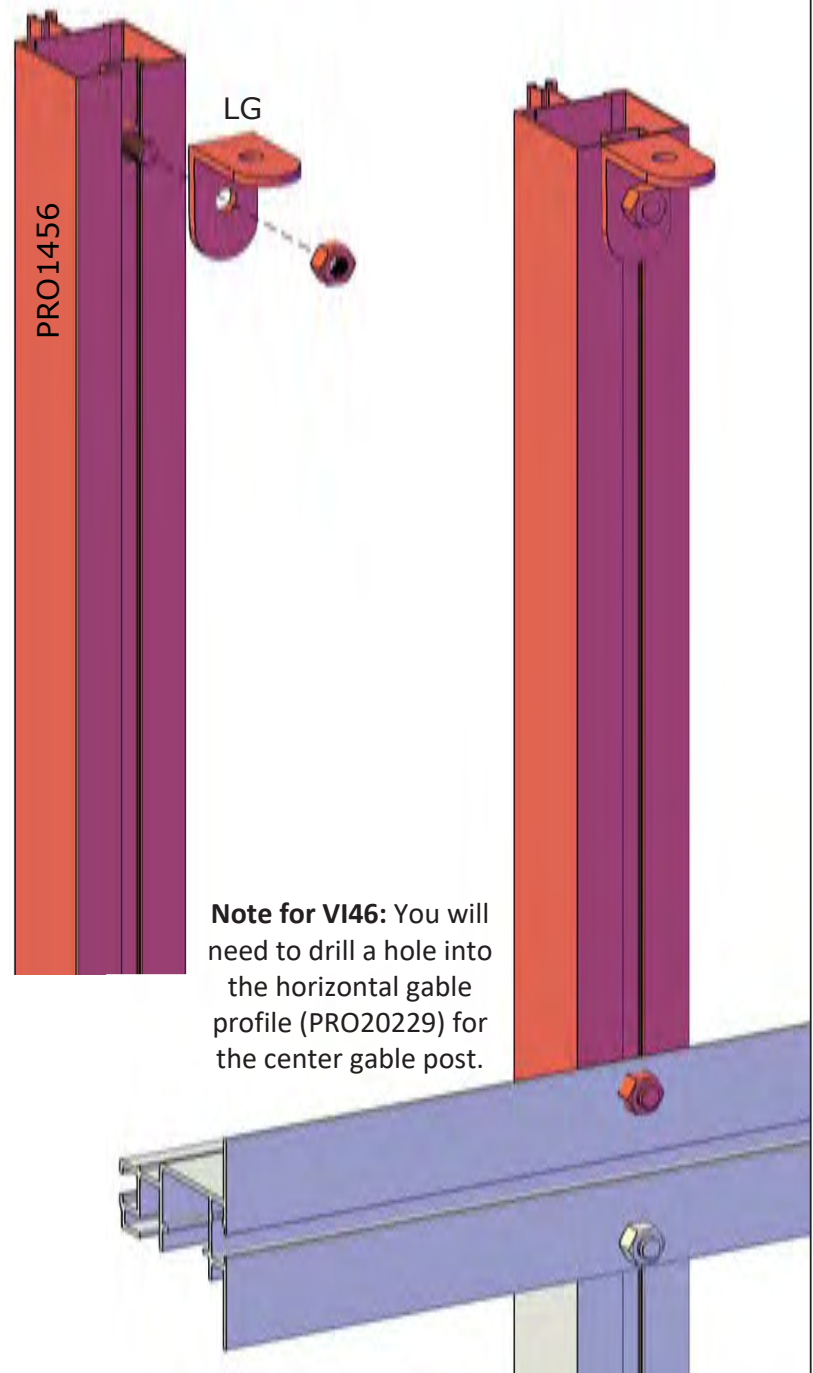

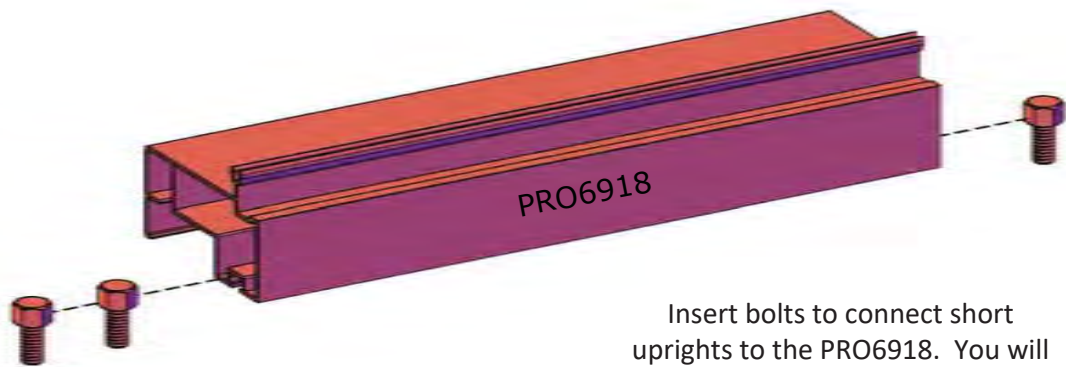

M6x12

Insert bolts to connect short uprights to the PRO6918. You will need as many bolts as you have short uprights.

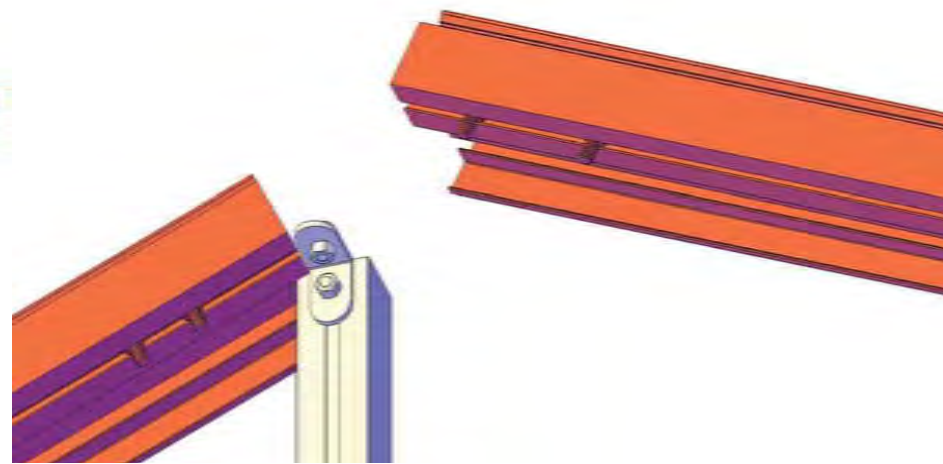

34

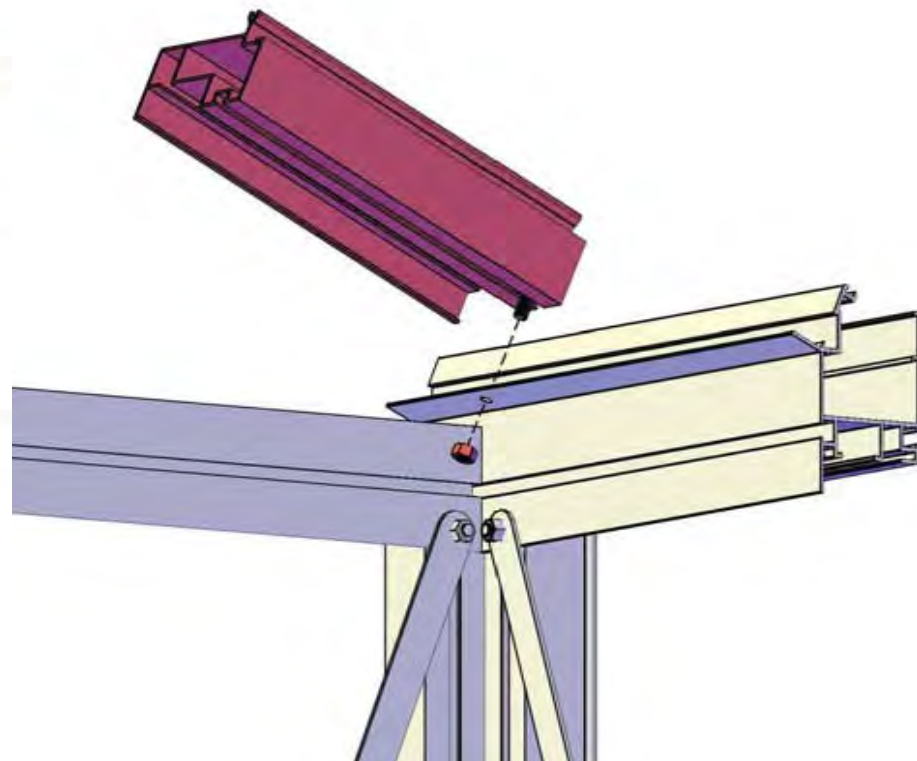



Only for models over
93" wide (i.e. VI34, 36,
46) NOT in VI23

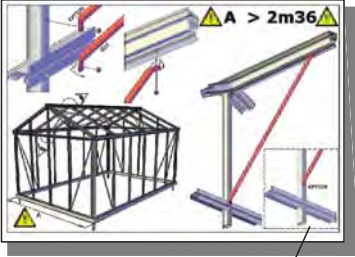

M6x12

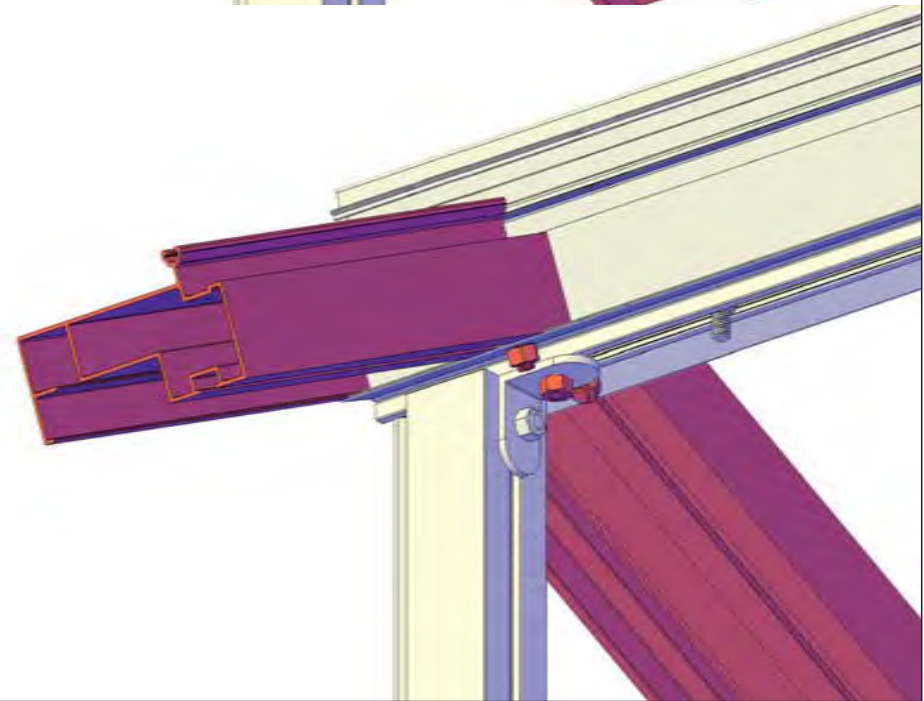
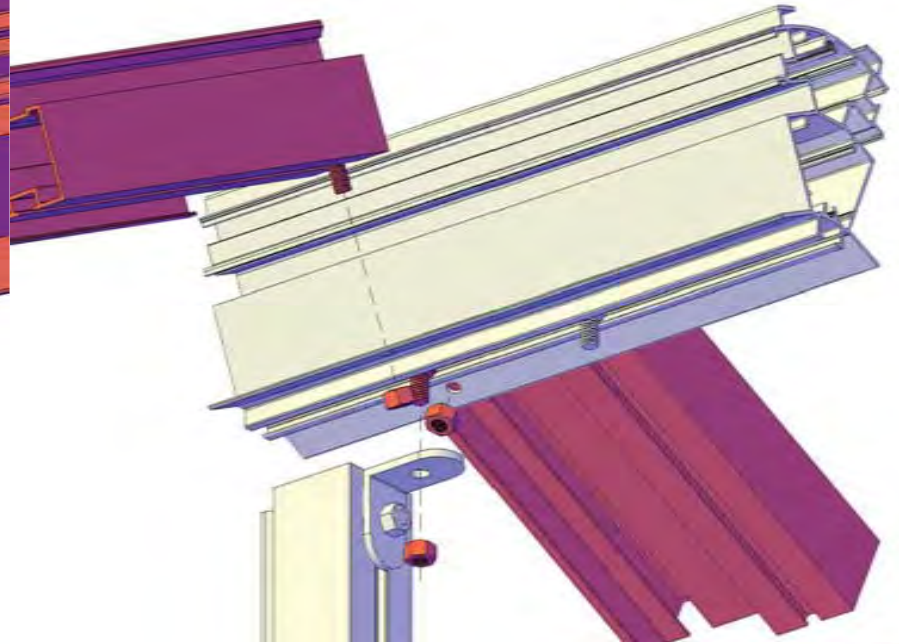
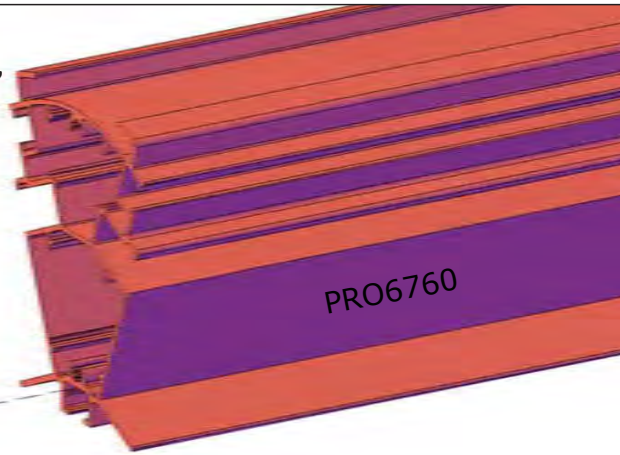

35

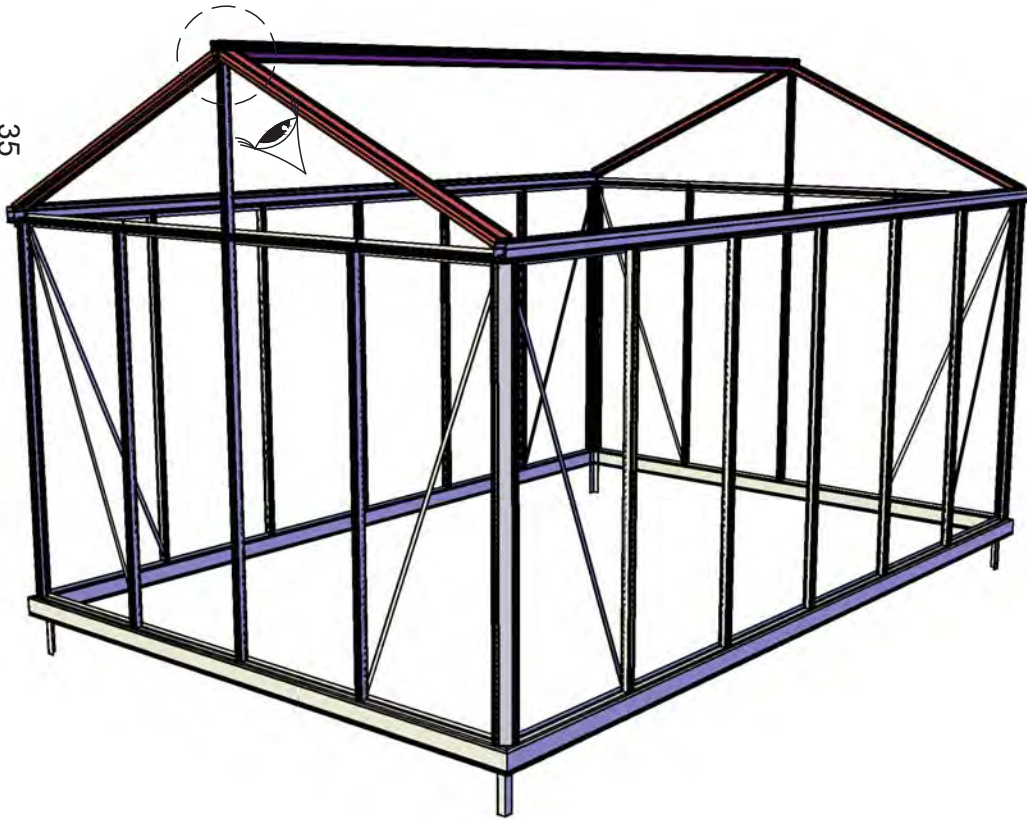

PRO1456

LG

M6x12



36

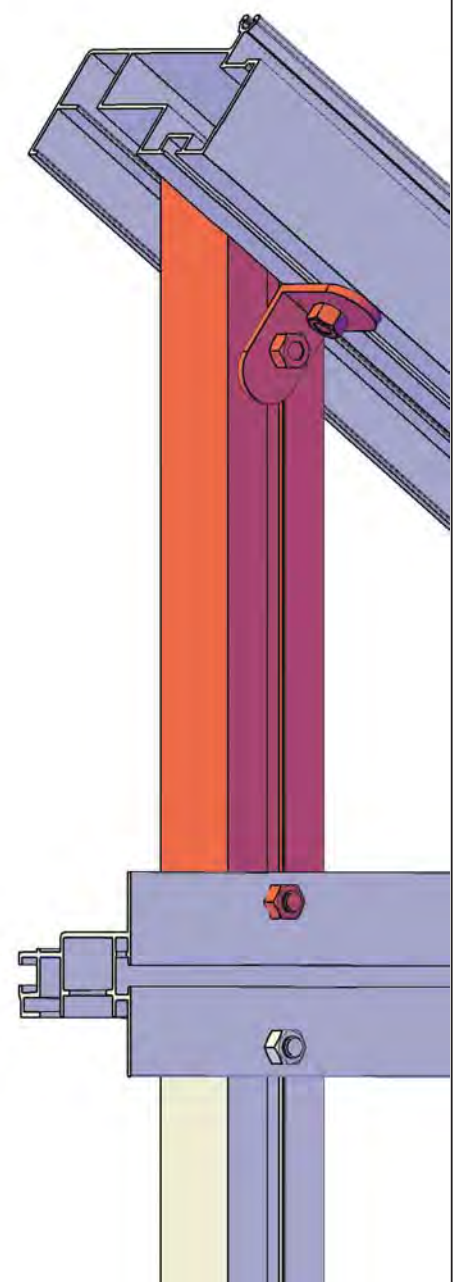
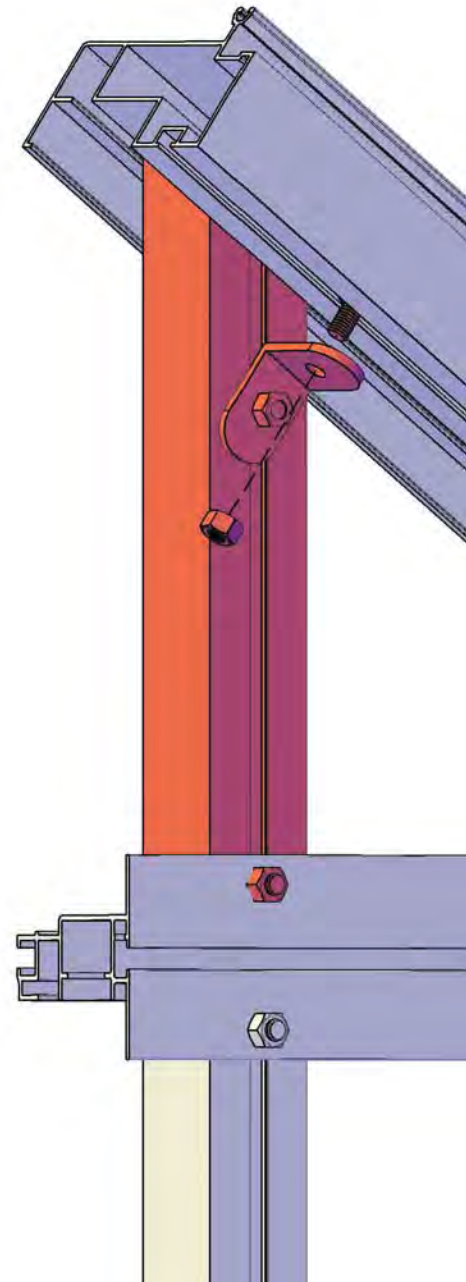
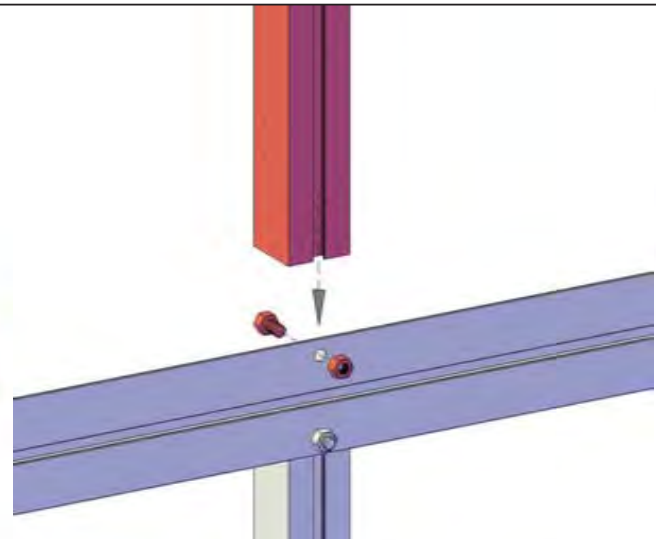

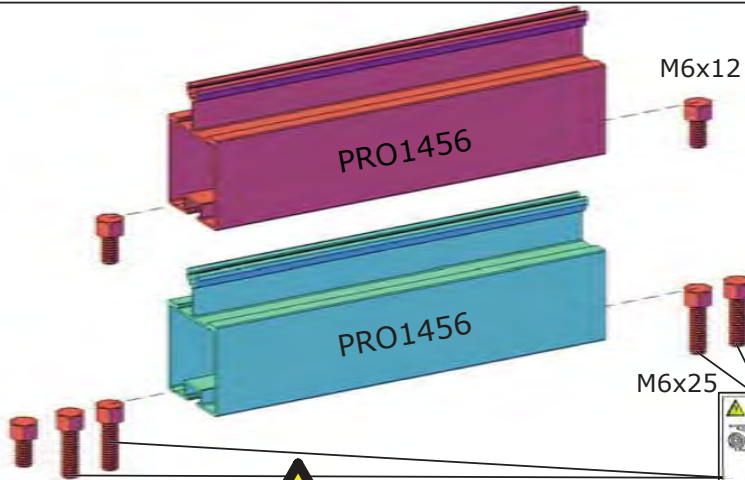

M6x12

PRO1456

PRO1456

Insert bolts into rafters to attach them to gutter profile (PRO20227) and ridge beam (PRO6760)

Only if length > 4580mm (i.e. VI36 and VI46) then insert 25mm long bolts (in Spandrel/ Scroll Support package) in the center rafters/ vertical wall profiles - see H_20 and H_21

M6x25

M6x12



Length > 181"

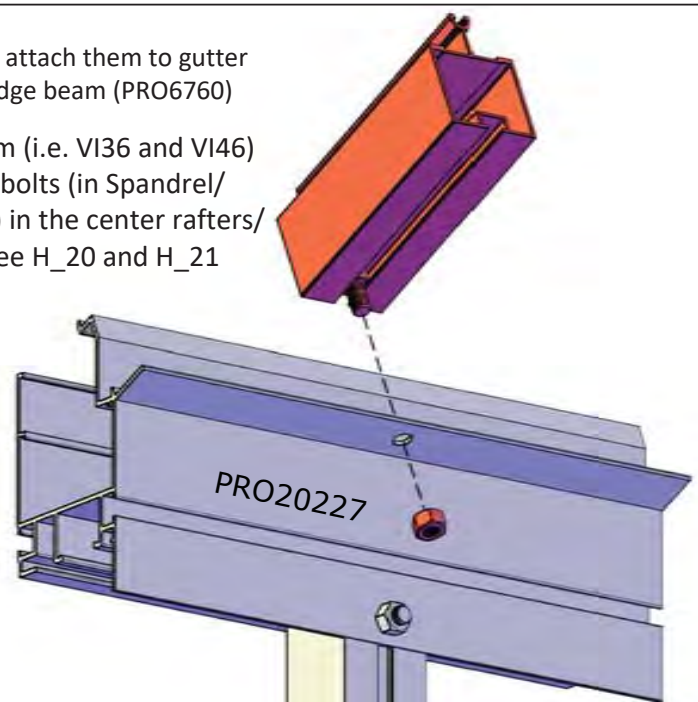

PRO20227

37

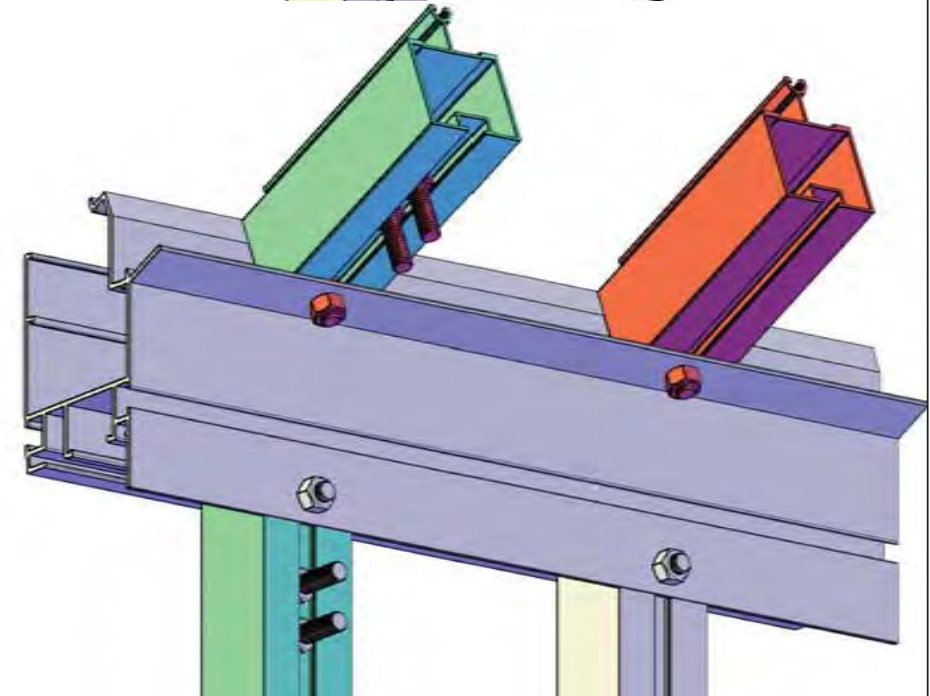

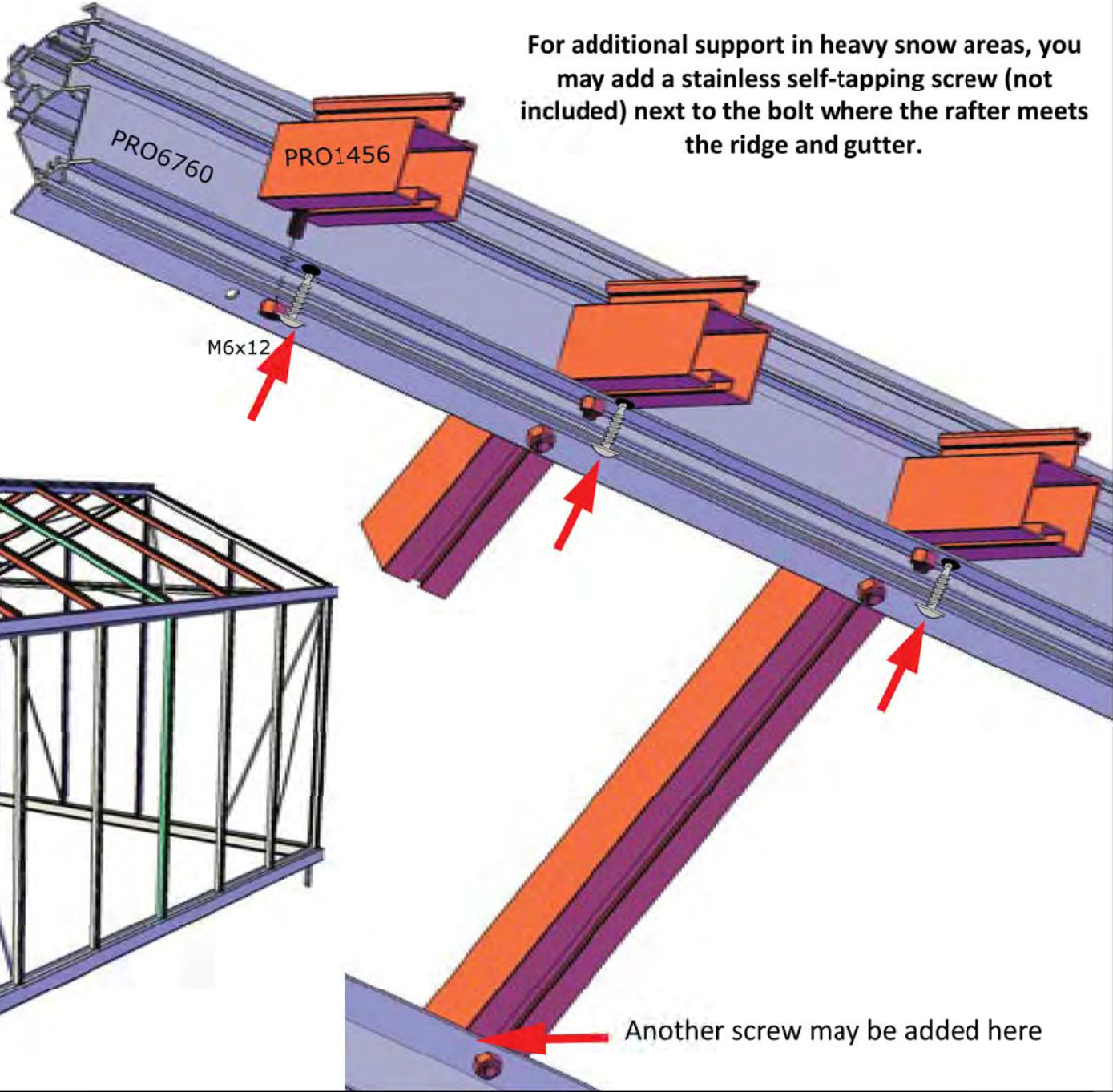

For additional support in heavy snow areas, you may add a stainless self-tapping screw (not included) next to the bolt where the rafter meets the ridge and gutter.

Another screw may be added here

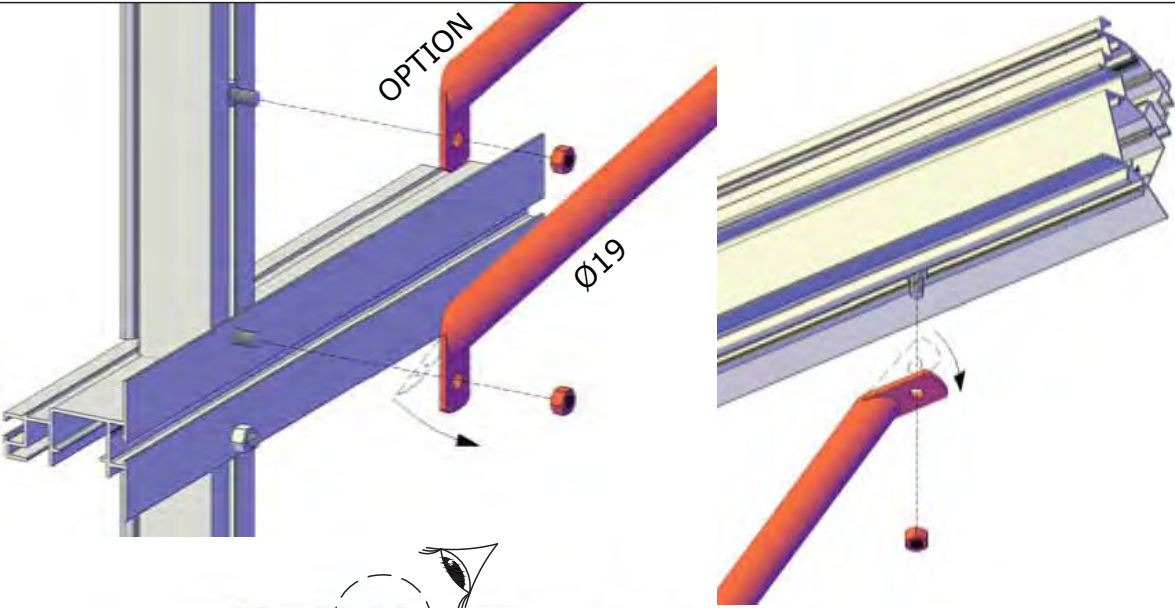

Width > 93"



Diagonal Support is only supplied with models over 2360mm - VI34, 36, 46.

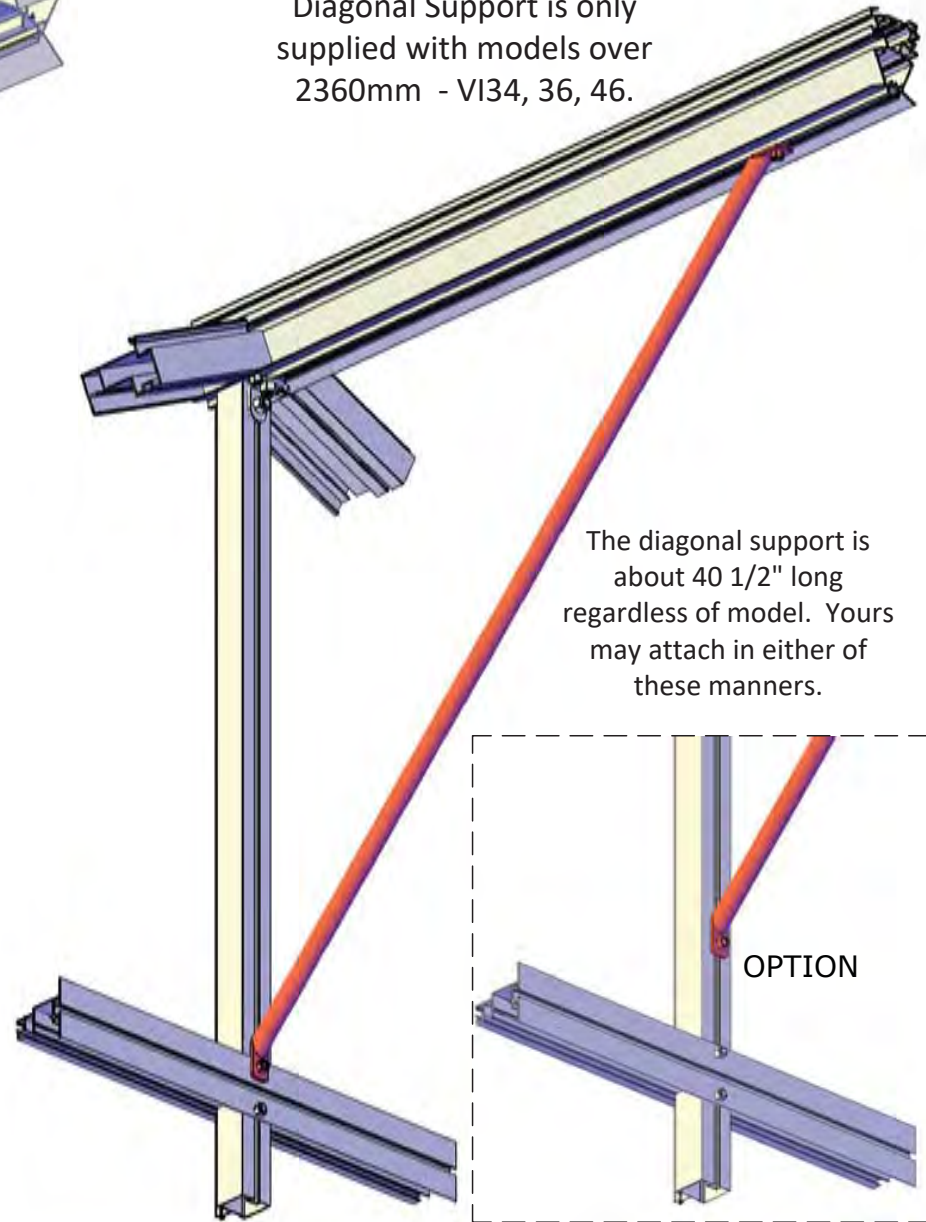

39

A



Placement of Roof Wind Braces (TRE) - View from above
Attach at ridge beam first with 12mm bolts

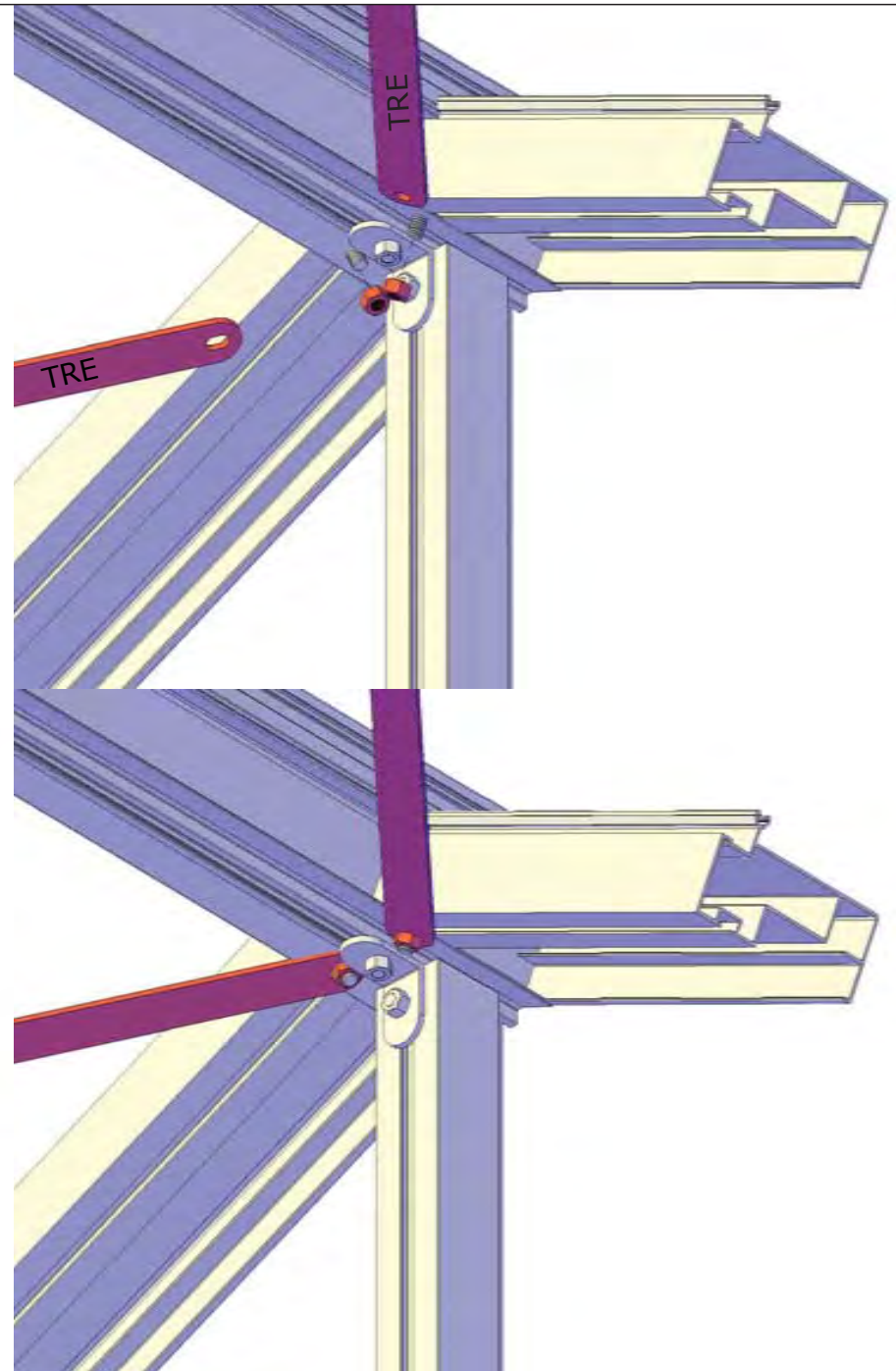
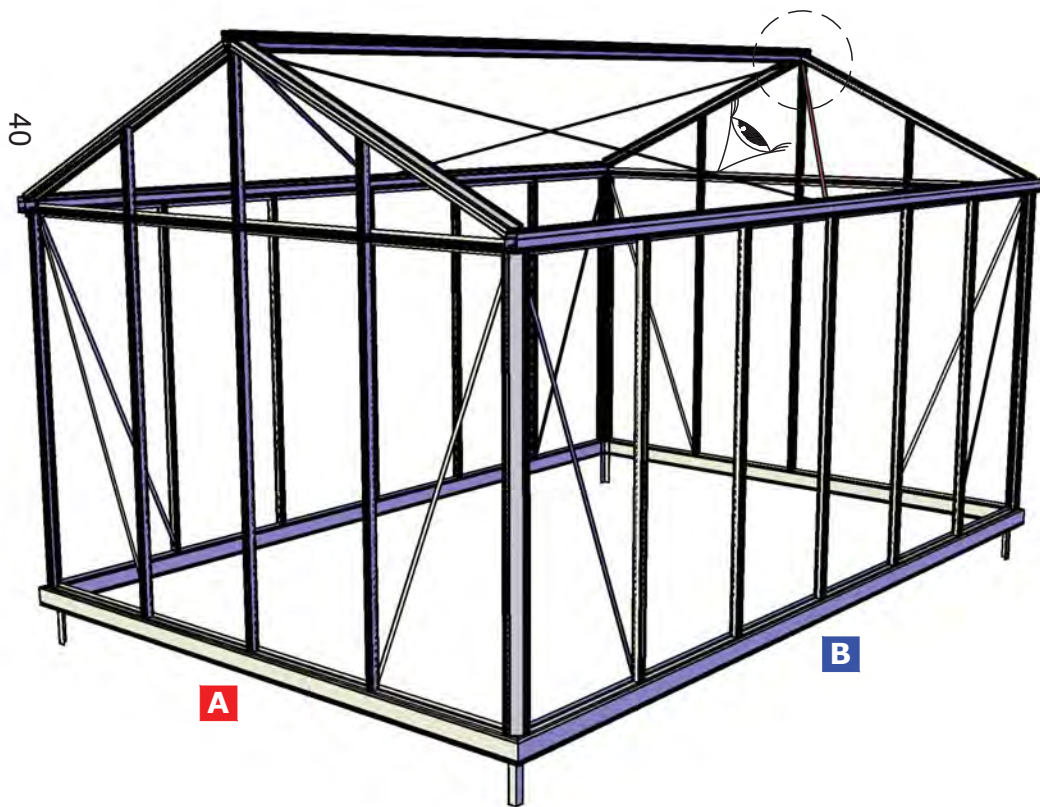
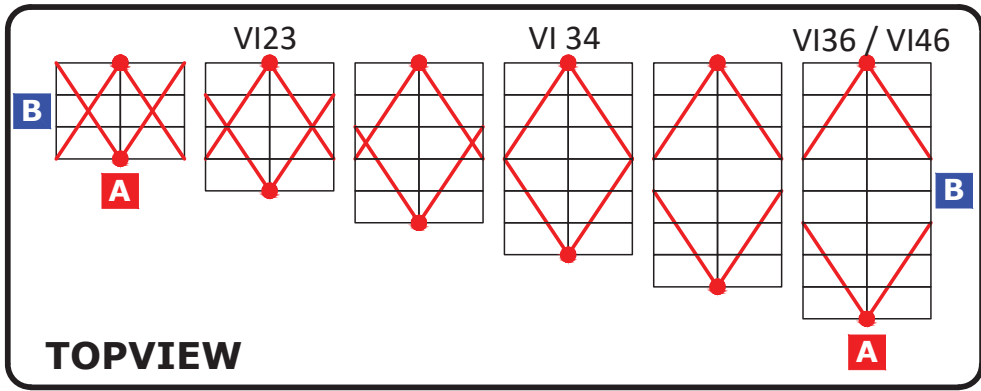

Placement of Wind Braces (TRE) View from above. Attach at gutter profile. **NOTE for VI34:** Use 25mm bolt in (ZAK_H) to accommodate both braces on a single bolt.

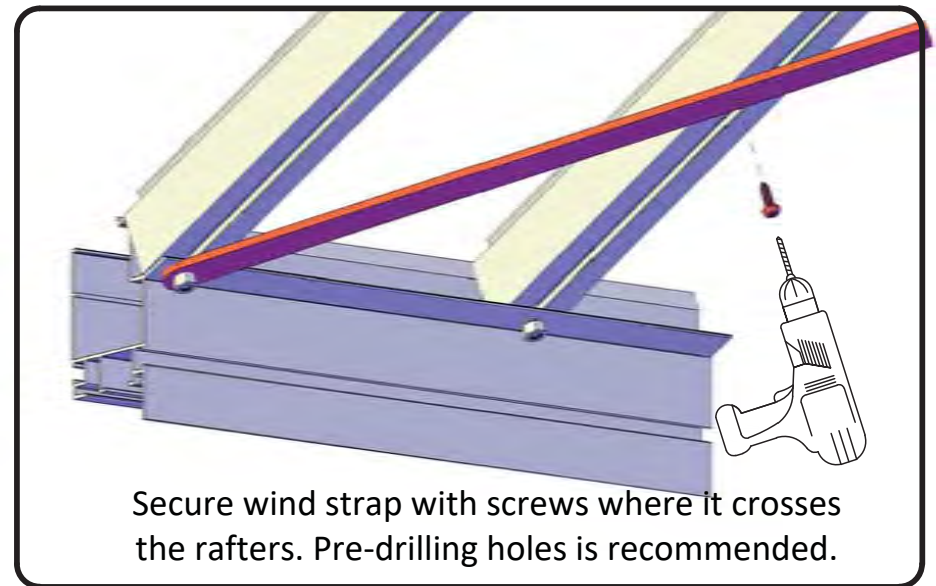
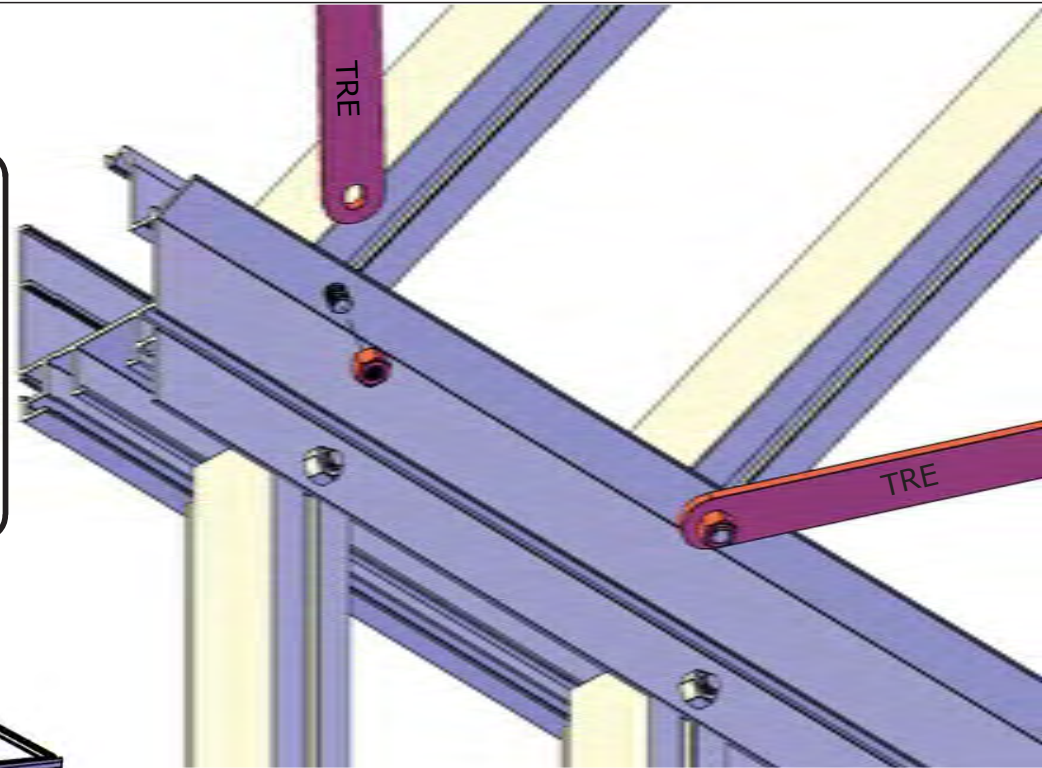
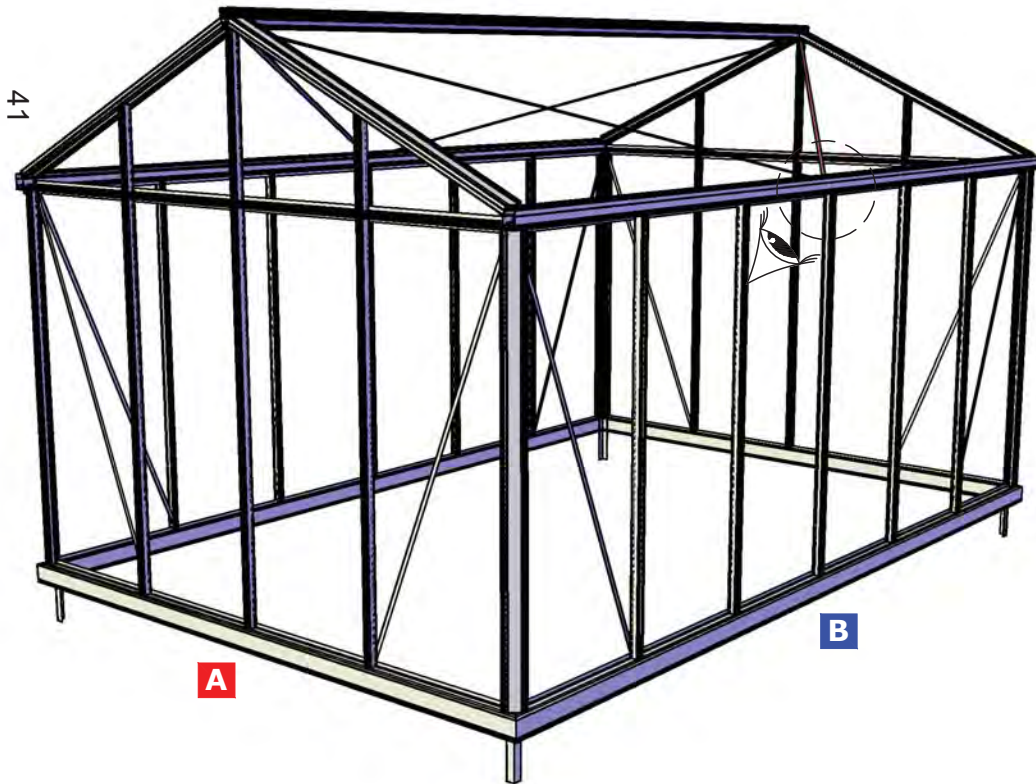
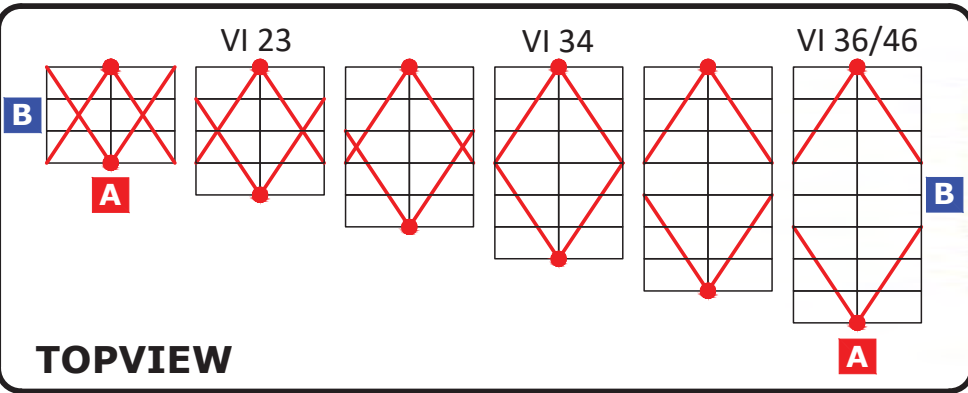

Spandrels/Deco Scroll Supports

Spandrels/Scroll supports are only included with VI36/ VI46 models.
Additional support may be ordered if more support is needed.

! Length > 181" !

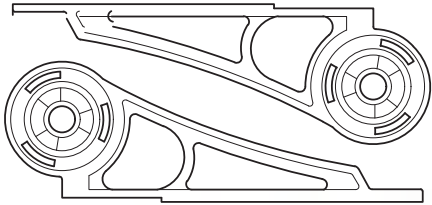

42

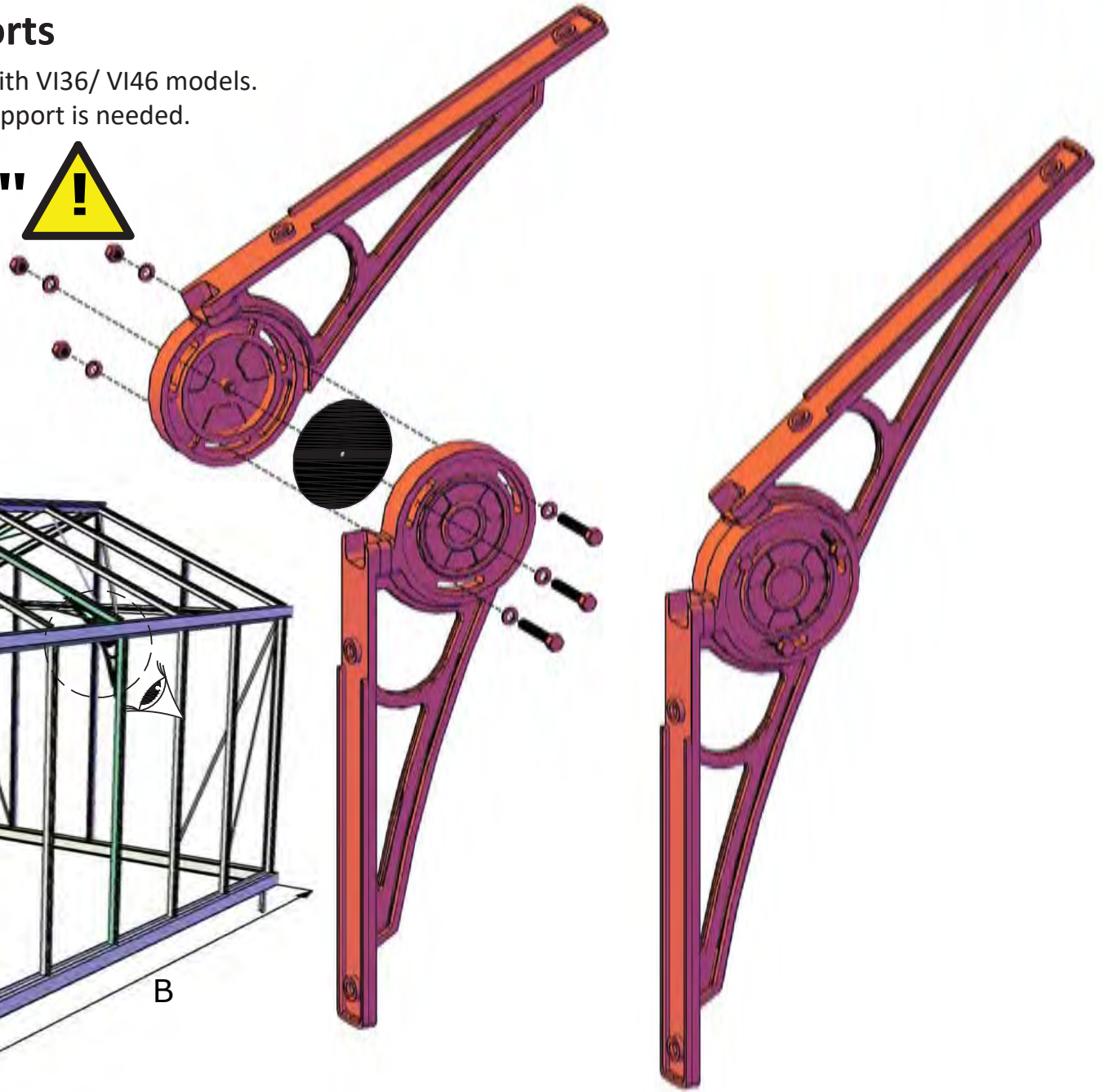
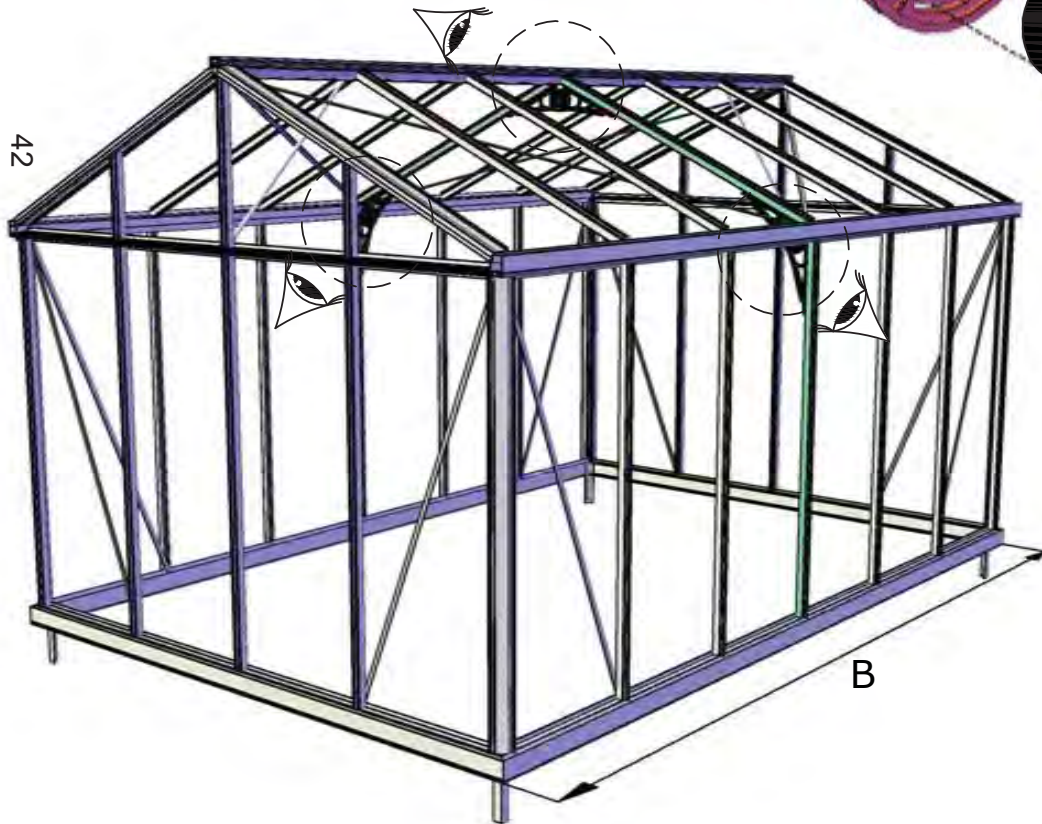

Spandrels/Deco Scroll Supports

Spandrels/Scroll supports are only included with VI36/ VI46 models.
Additional support may be ordered if more support is needed.



Length > 181"



43

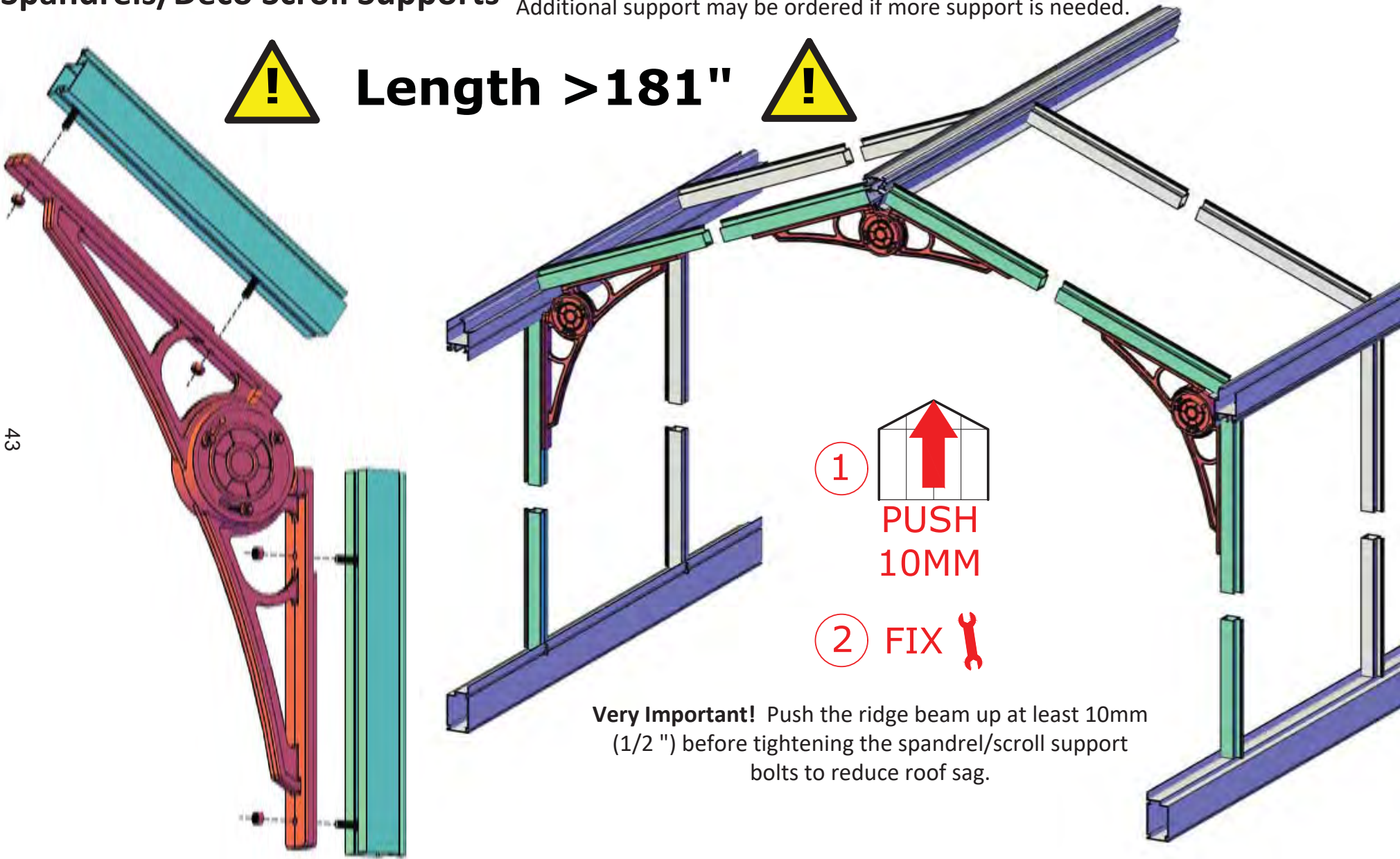

Very Important! Push the ridge beam up at least 10mm (1/2 ") before tightening the spandrel/scroll support bolts to reduce roof sag.

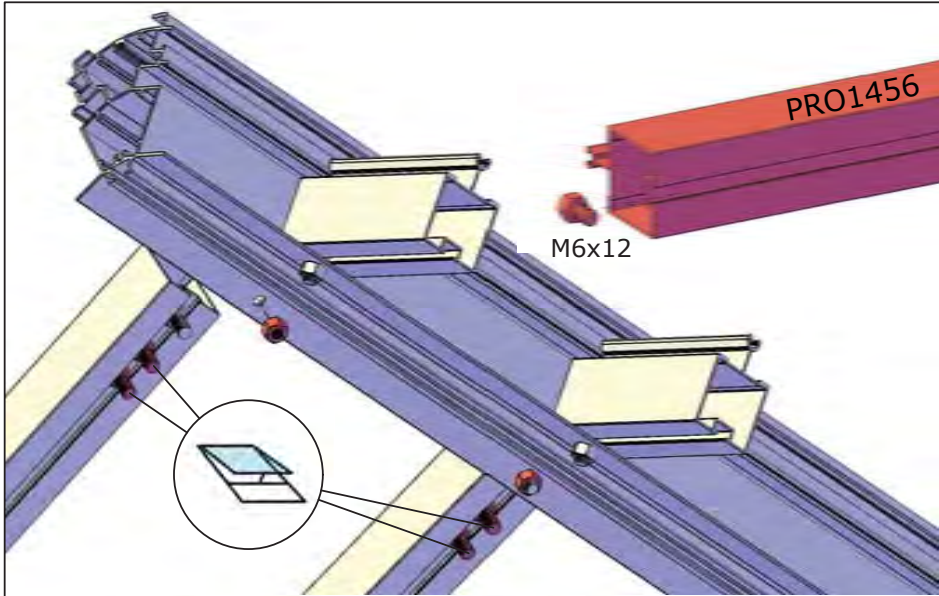

Crossbar for framing roof vent opening will be found in each Roof Window bag/package. Roof vents may be installed in any bay. They may not be placed side by side.

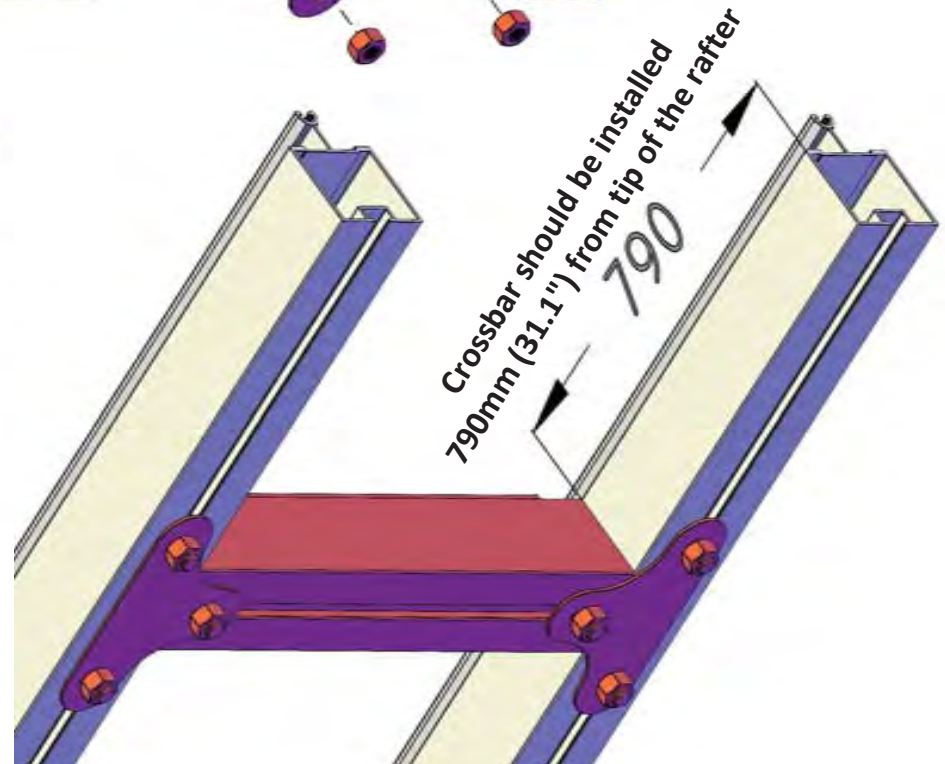
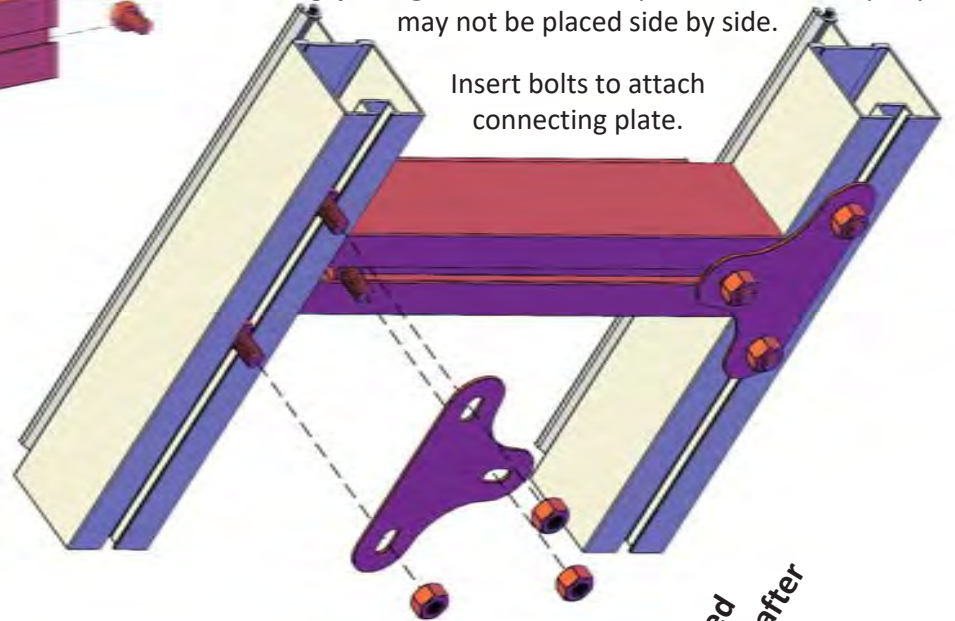

This page applies only to "RETRO" Model

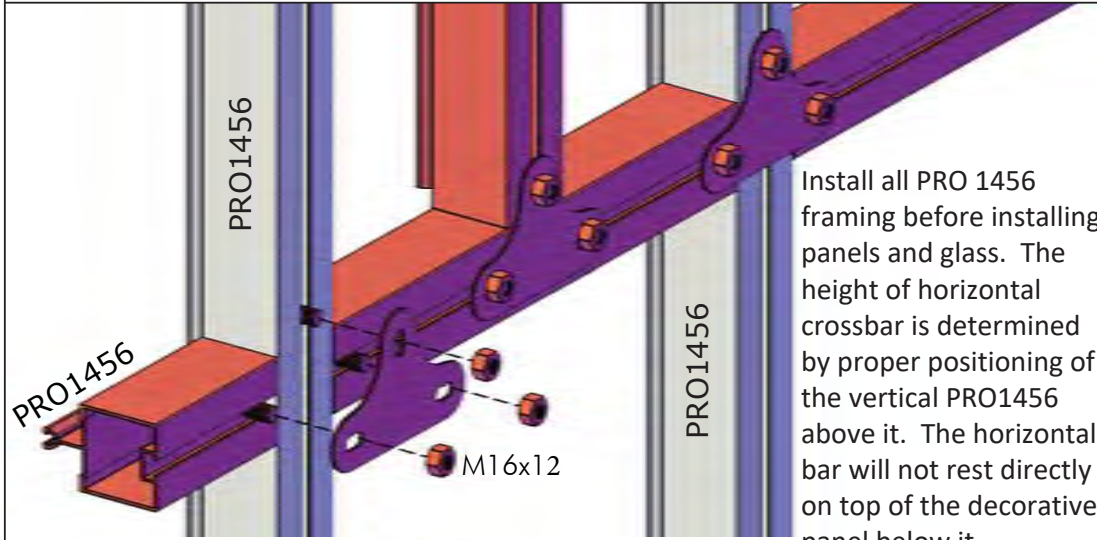

Install all PRO 1456 framing before installing panels and glass. The height of horizontal crossbar is determined by proper positioning of the vertical PRO1456 above it. The horizontal bar will not rest directly on top of the decorative panel below it.

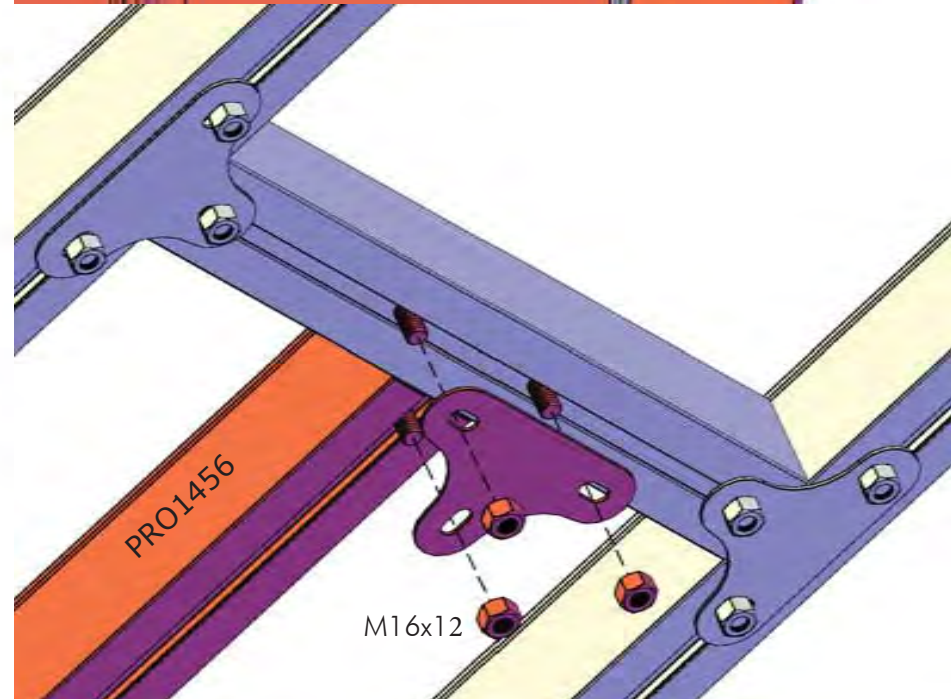
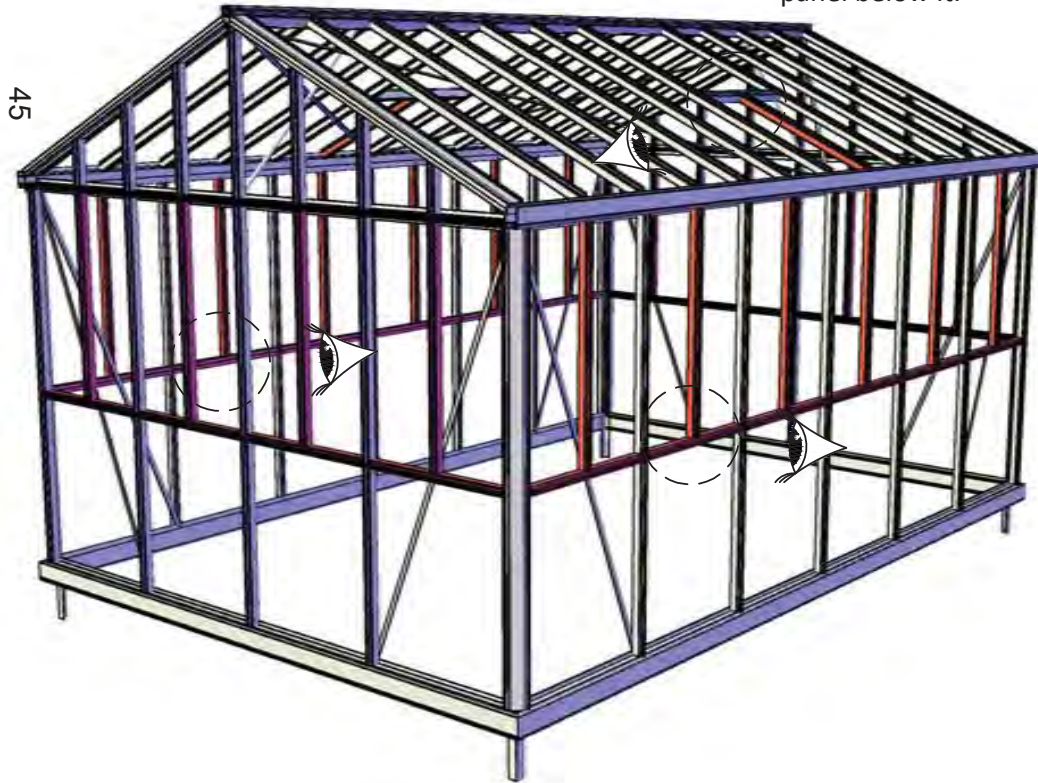
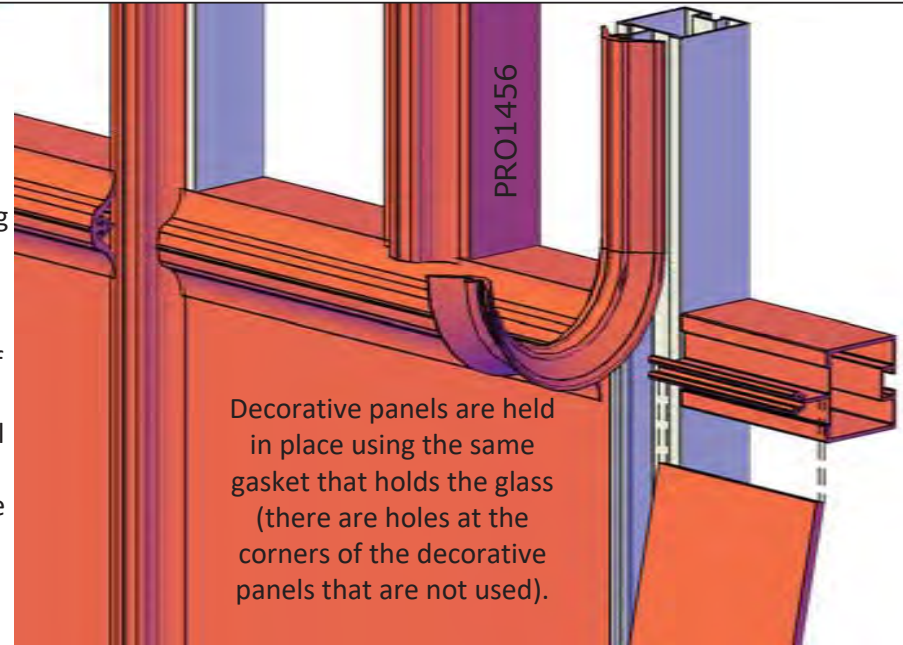

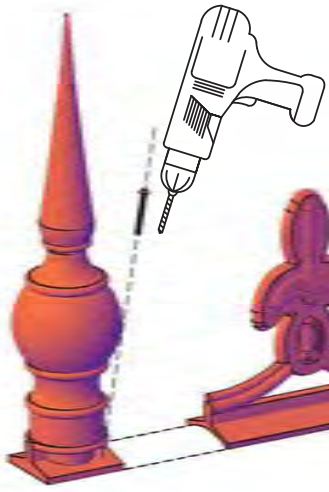

Use 19mm screw from ZAK_H

Roof decorations may be installed at this point or after glazing is installed if desired. It may be easier to install glazing gaskets if the roof decoration is installed at the very end. Roof decorations are optional and may be omitted if desired.

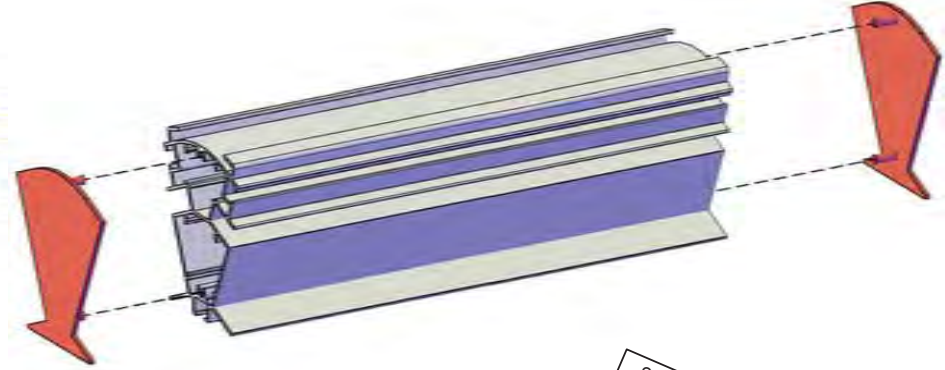
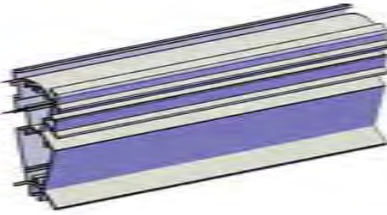

46

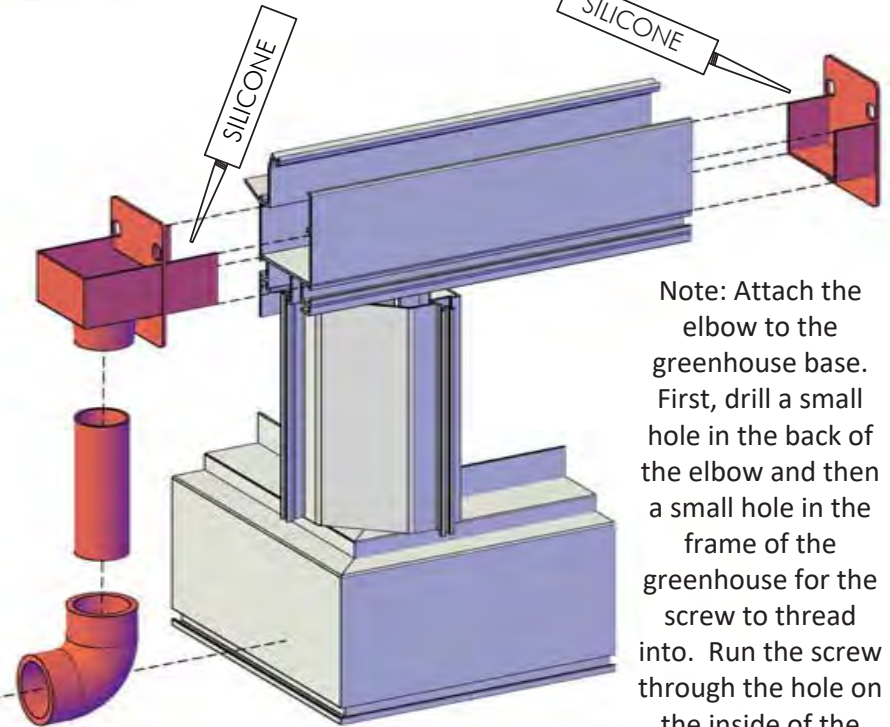
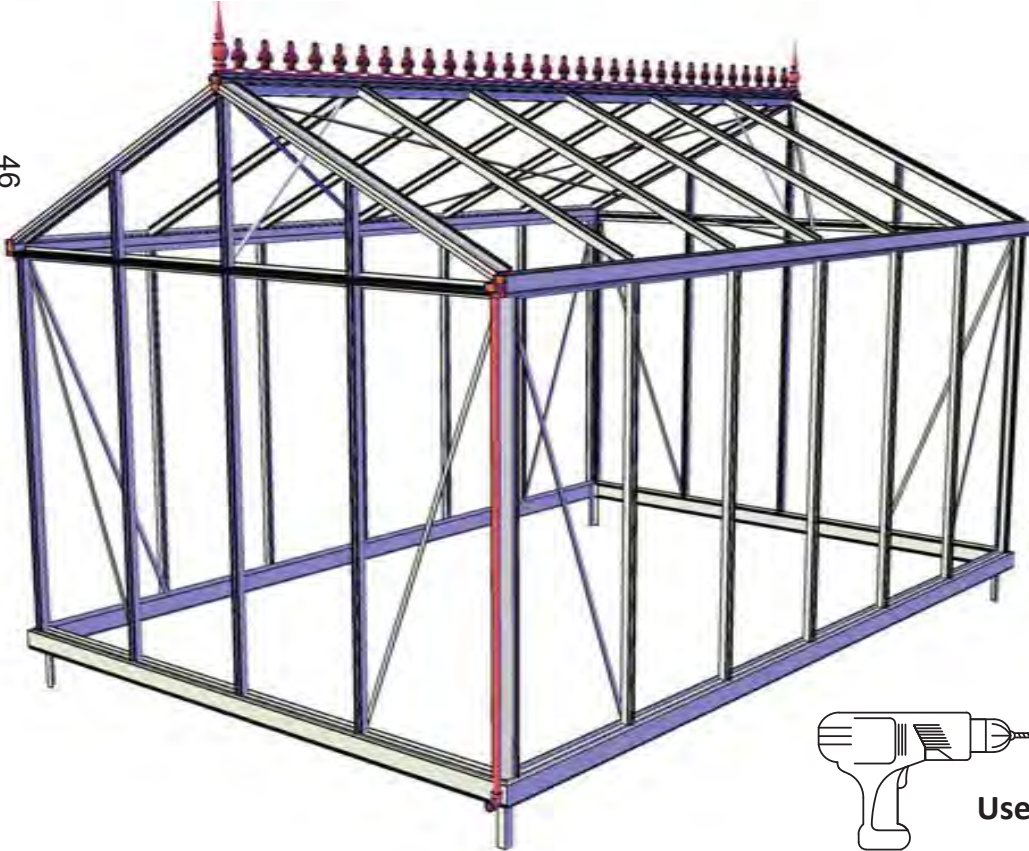

Note: Attach the elbow to the greenhouse base. First, drill a small hole in the back of the elbow and then a small hole in the frame of the greenhouse for the screw to thread into. Run the screw through the hole on the inside of the elbow and into the greenhouse base.



Use 38mm screw from (ZAK_H)

You are now ready to install your glazing. If you have polycarbonate glazing, please refer to next page for specific prep regarding the polycarbonate panels - you will not use the crescent shaped gasket (E400330) with your polycarbonate panels.

Tips for installing your glazing (more detailed steps/diagrams follow - this is an overview):

Use the provided glass suction cup - it helps a lot!

Wait until the end to install your roof vents - it will be easier to pop through the openings as needed to place the roof pieces and gaskets.

Start with your small, angled gable ends. For the smallest corner pieces, you may need to remove the vertical profile (PRO1456) next to it. Place the glazing, then replace profile. Secure the glass with the heavy duty gasket (PRO1748) on the verticals. Insert the crescent gasket (E400330) into the eaves (see figure on following pages) - it will be held in a flange that is further up than the one you can see.

Do the roof next - always work one pane at a time! Slide top edge of glass into the ridge beam and set bottom into glassholder (PRO20780). Place one pane, then insert crescent gasket (E400330) into ridge and heavy duty gasket (PRO1748) into the channel on the rafter (PRO1456) on the far side of the glass. Place the next piece of glazing, then insert crescent gasket into ridge and the heavy duty gasket into the rafter on the far side. Repeat for the rest of the roof. You will also add the heavy duty gasket into the crossbar (PRO1456) that frames the roof vent openings.

Finally place your sidewall panes, working one at a time. Place a panel, then secure one side with heavy duty gasket (PRO1748), place next panel, then secure where the two panel meet with gasket (PRO1748). **NOTE:** The crescent gasket (E400330) is **NOT** inserted at the top of the sidewall. There will be no gasket there.

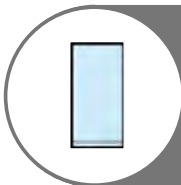

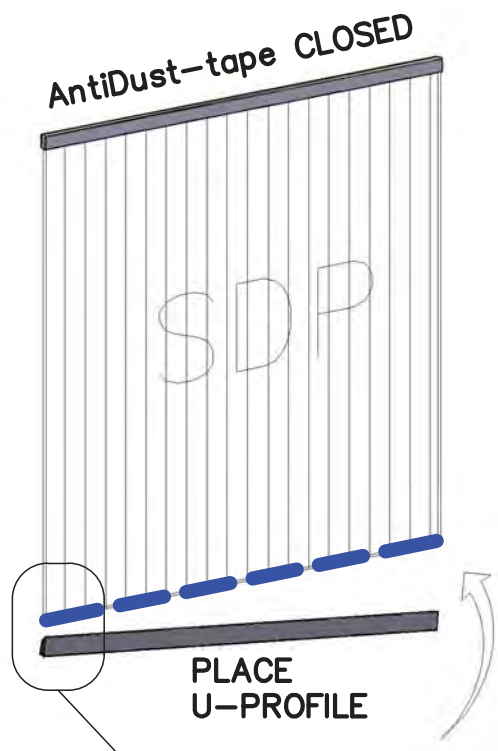
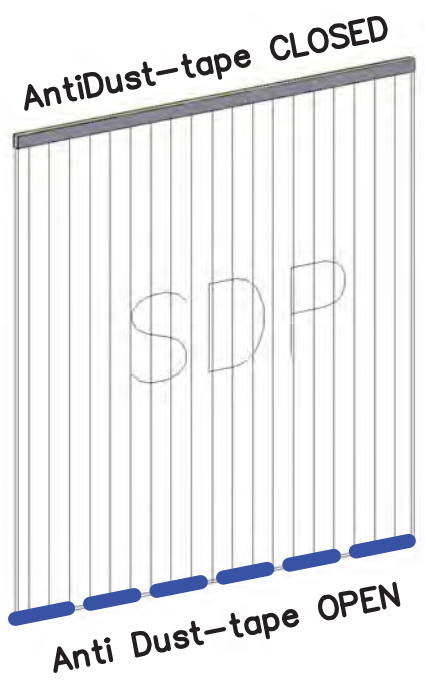

OPTION: Polycarbonate 10mm SDP



You will find a bundle of WHITE U profiles in the pallet. Place them over the vented tape. This will be the bottom of your polycarbonate panel. The U channel creates a space for any condensation to exit and move away from the panel. (white is the only available color)

Do not add U profiles on polycarbonate for doors, vents, or windows.

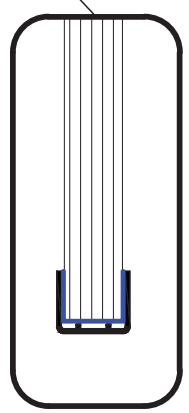
You will not use the crescent gasket with polycarbonate panels. It is included with the pallet but it is not used on the polycarbonate models.



Find Glass Holders in ZAK_H (with your gutter pieces and other hardware

4mm GLASS



PRO20227

10mm POLYCARBONATE



PRO20227

Glazing supports slide onto the gutter profile, space them 100mm or 4 inches from each roof profile.

Standard width panes, use 2 per piece

130
28 3/4"

2 PCS

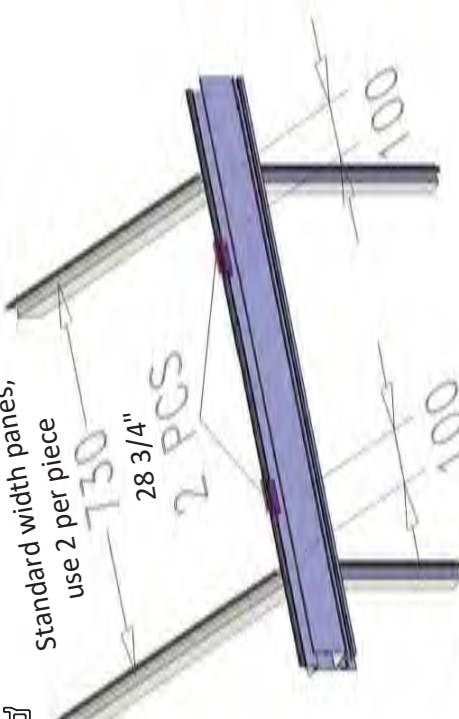

14 1/4"
Narrow glass panes
1 PC

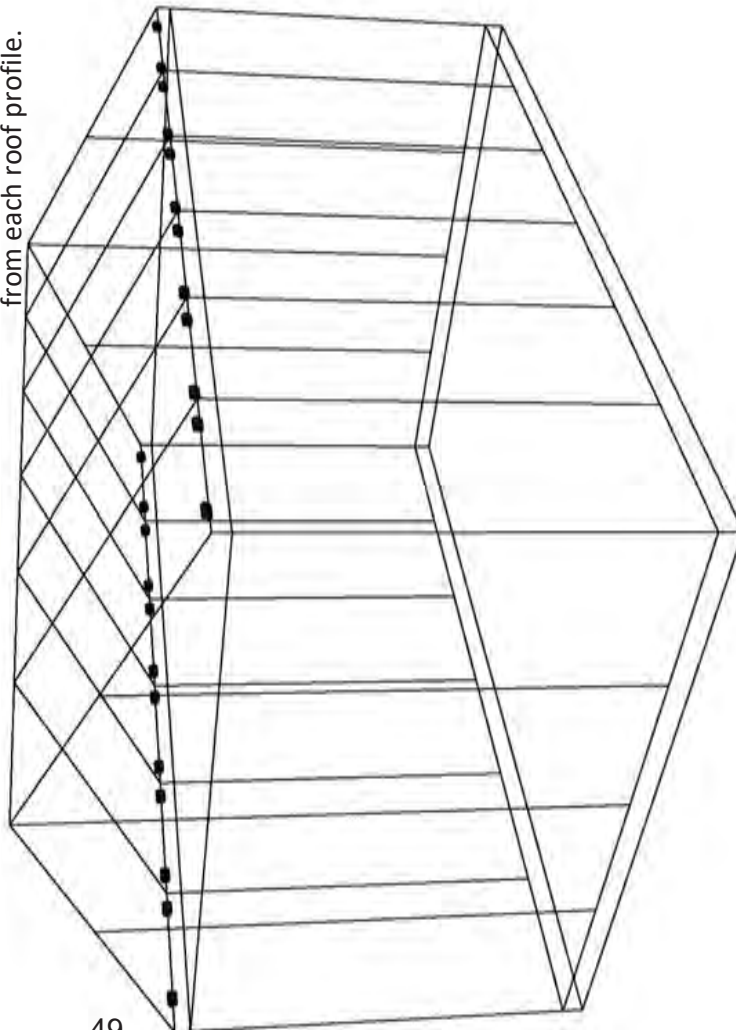
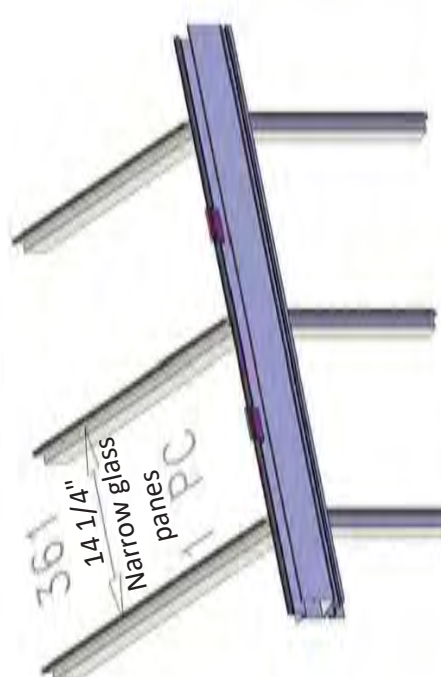

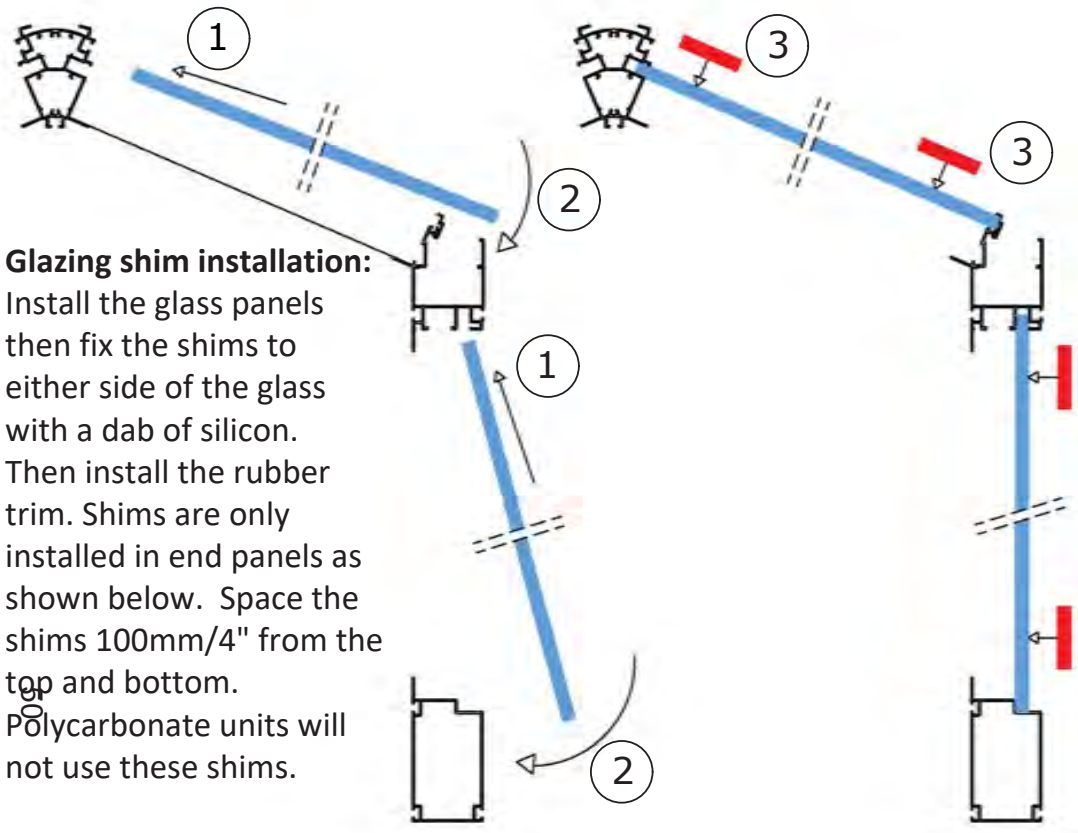

Glazing shim installation:

Install the glass panels then fix the shims to either side of the glass with a dab of silicon. Then install the rubber trim. Shims are only installed in end panels as shown below. Space the shims 100mm/4" from the top and bottom. Polycarbonate units will not use these shims.

To install gasket, roll it back on itself as shown. This exposes the inner flange that is pushed into the channel. It will be easier to insert when warm and pliable.

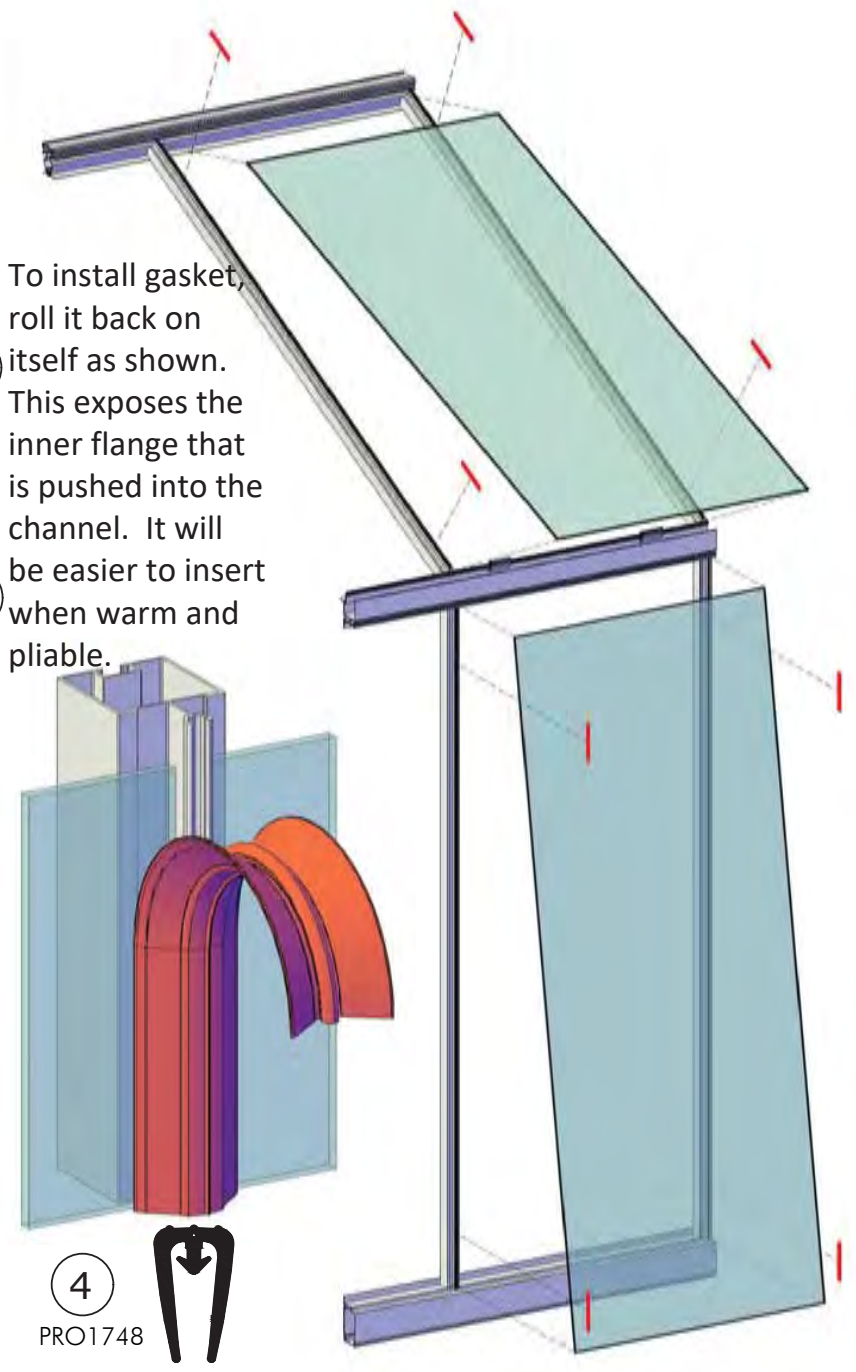
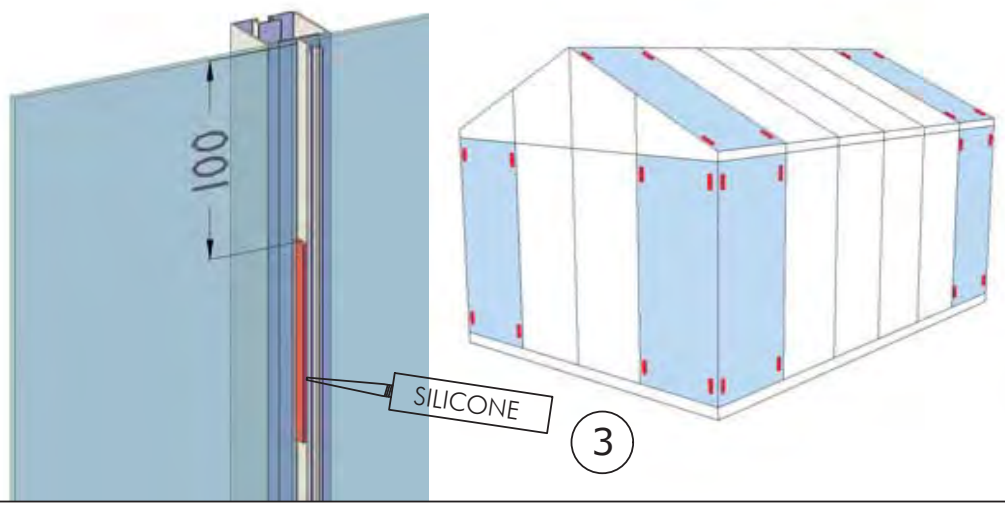

4
PRO1748

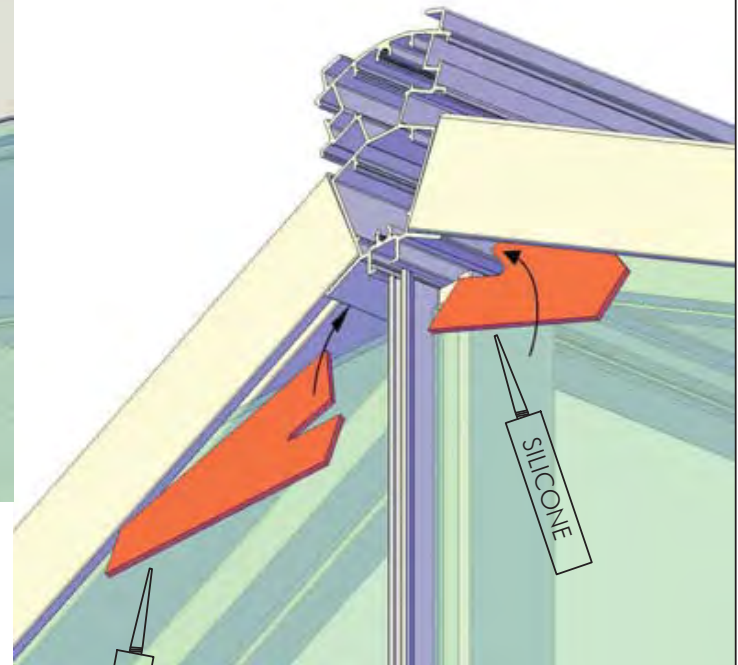
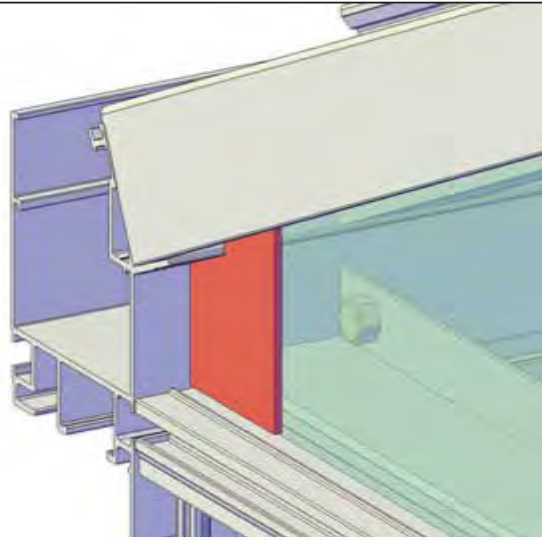
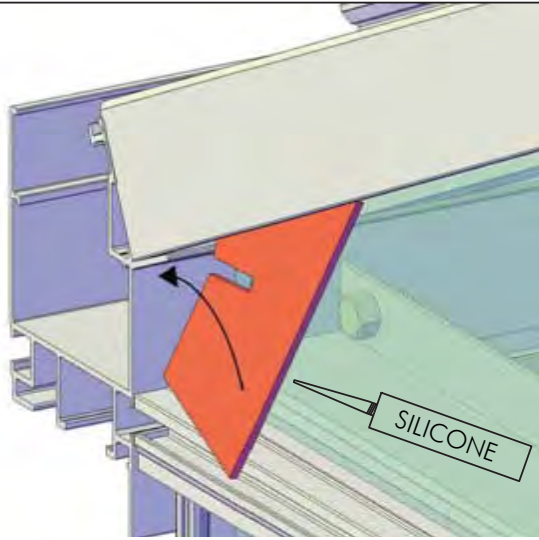

SILICONE

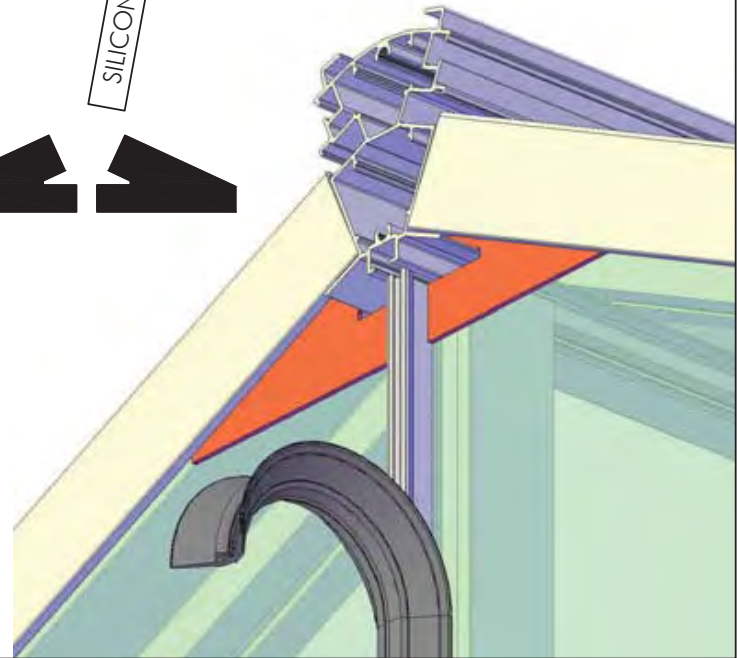



Crescent seal is only installed in the eaves and roof.

Not along side walls.

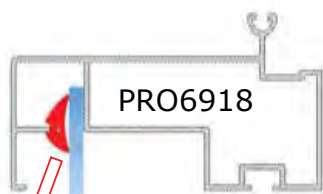

It helps to use a tool to push the gasket up under the eaves. Note that it inserts under the second flange further up.

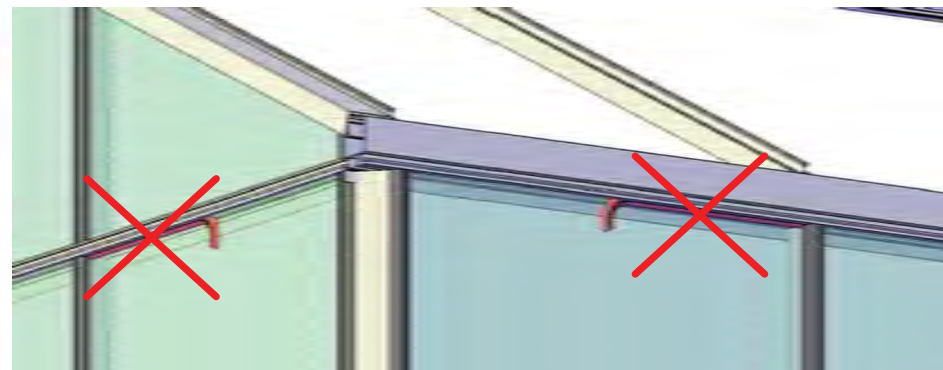
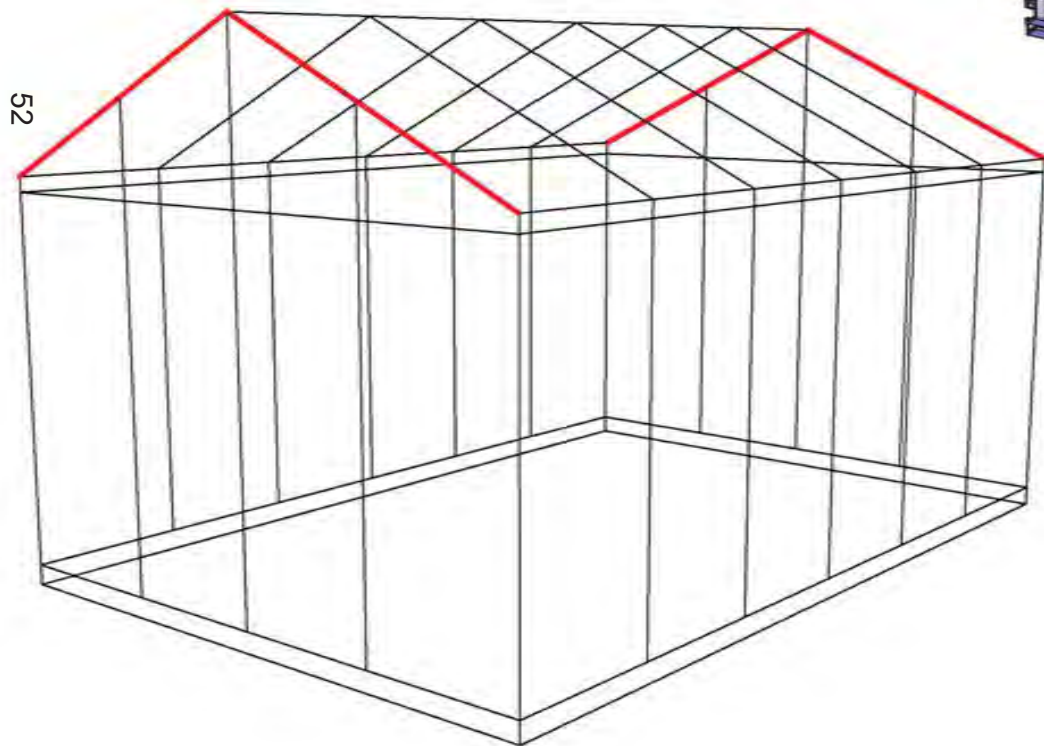
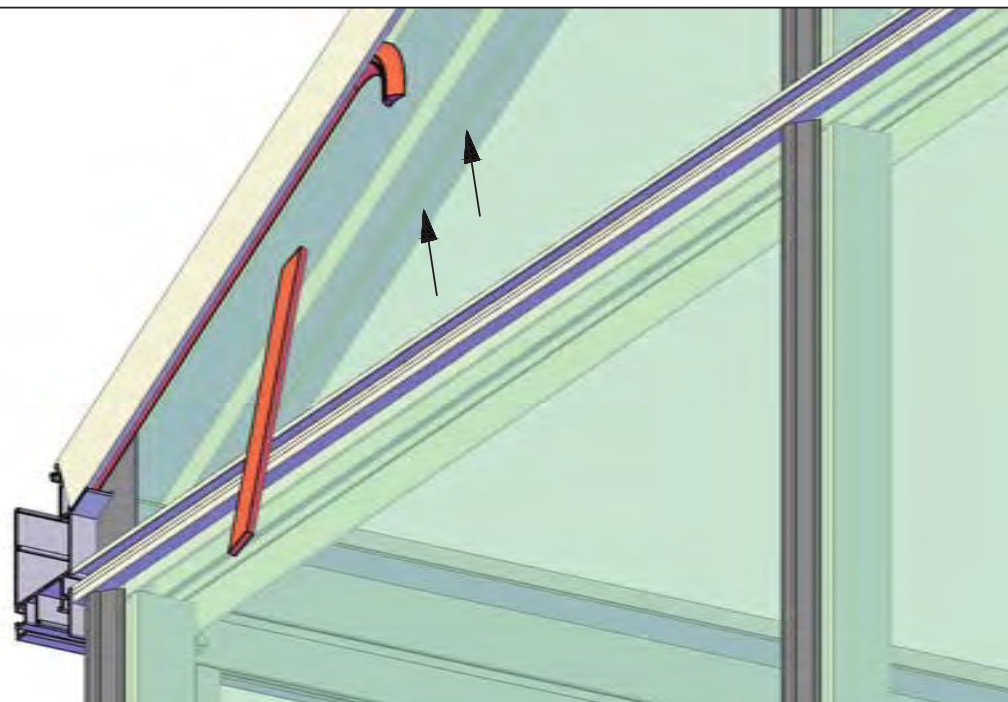

Crescent seal is only installed in the eaves and roof. Not along side walls.

To install heavy gasket, it is easiest to roll it back on itself as shown. This exposes the inner flange that is pushed into the channel. It will be easier to insert when warm and pliable. Install the roof glazing pane by pane, inserting gaskets after each.

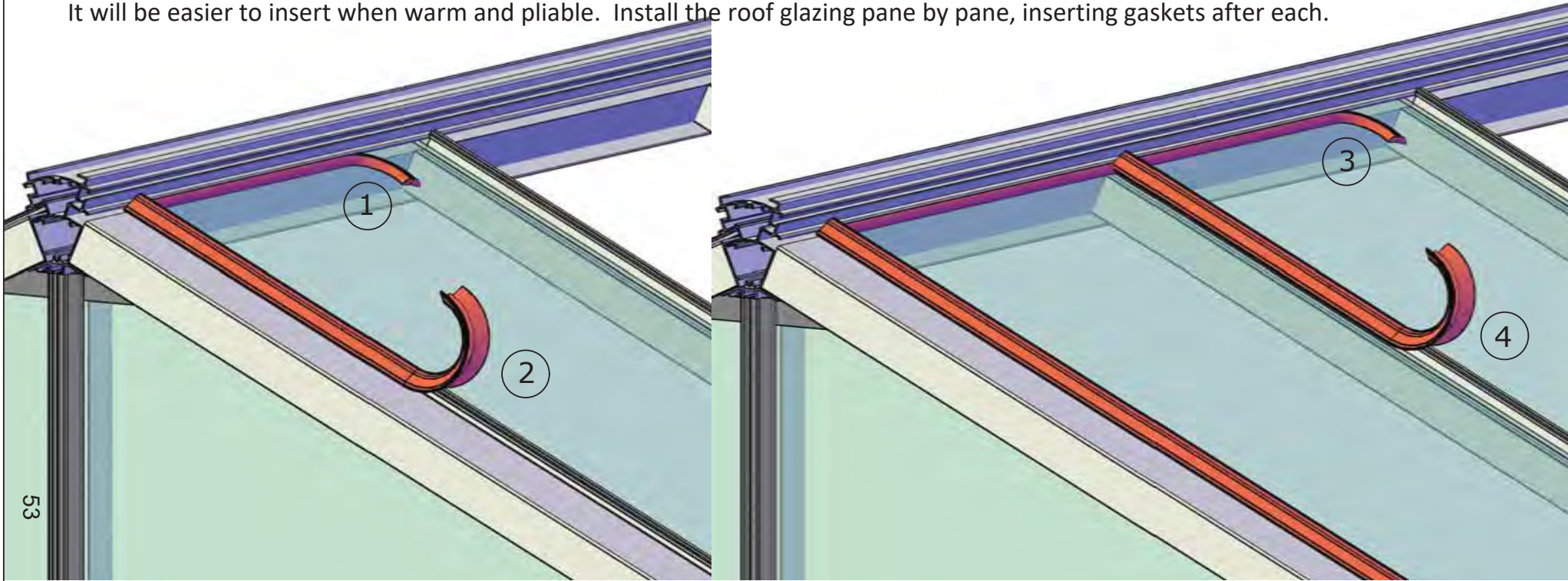

53

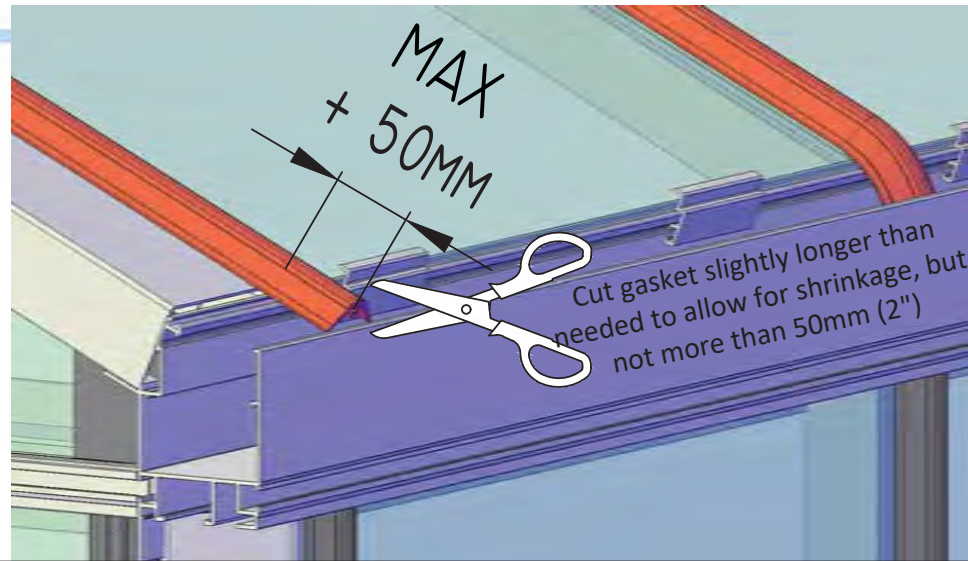
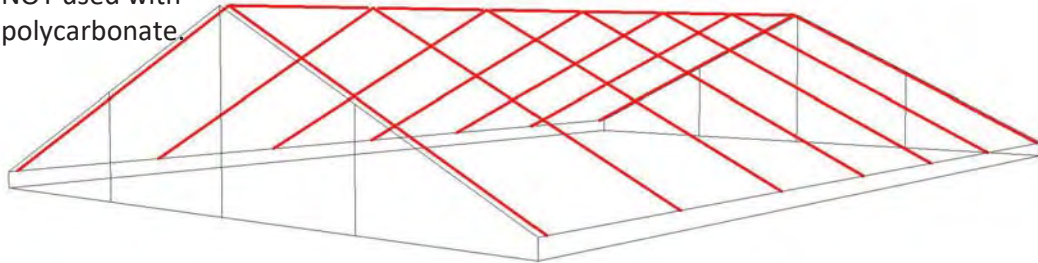
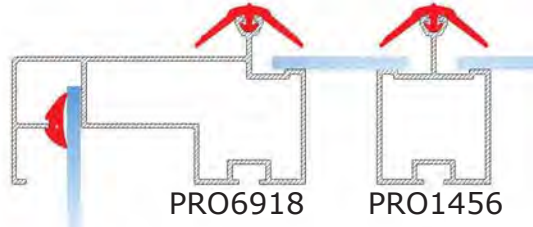
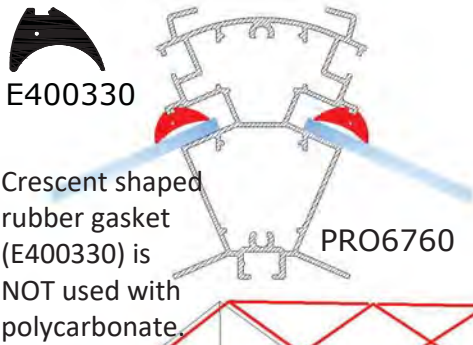

ACCESSORIES

This section contains many of the optional accessories.

You will have some, but likely not all, items seen in this section.

IMPORTANT: Scan the QR codes below to take you to our accessories installation video on YouTube and to our accessories page on our website.

QR Code for Website



QR Code for Accessories
Video on YouTube





Sliding Door (Standard for most models). VI36 and 46 come with a double sliding door. Additional doors may be added to your greenhouse.

SD

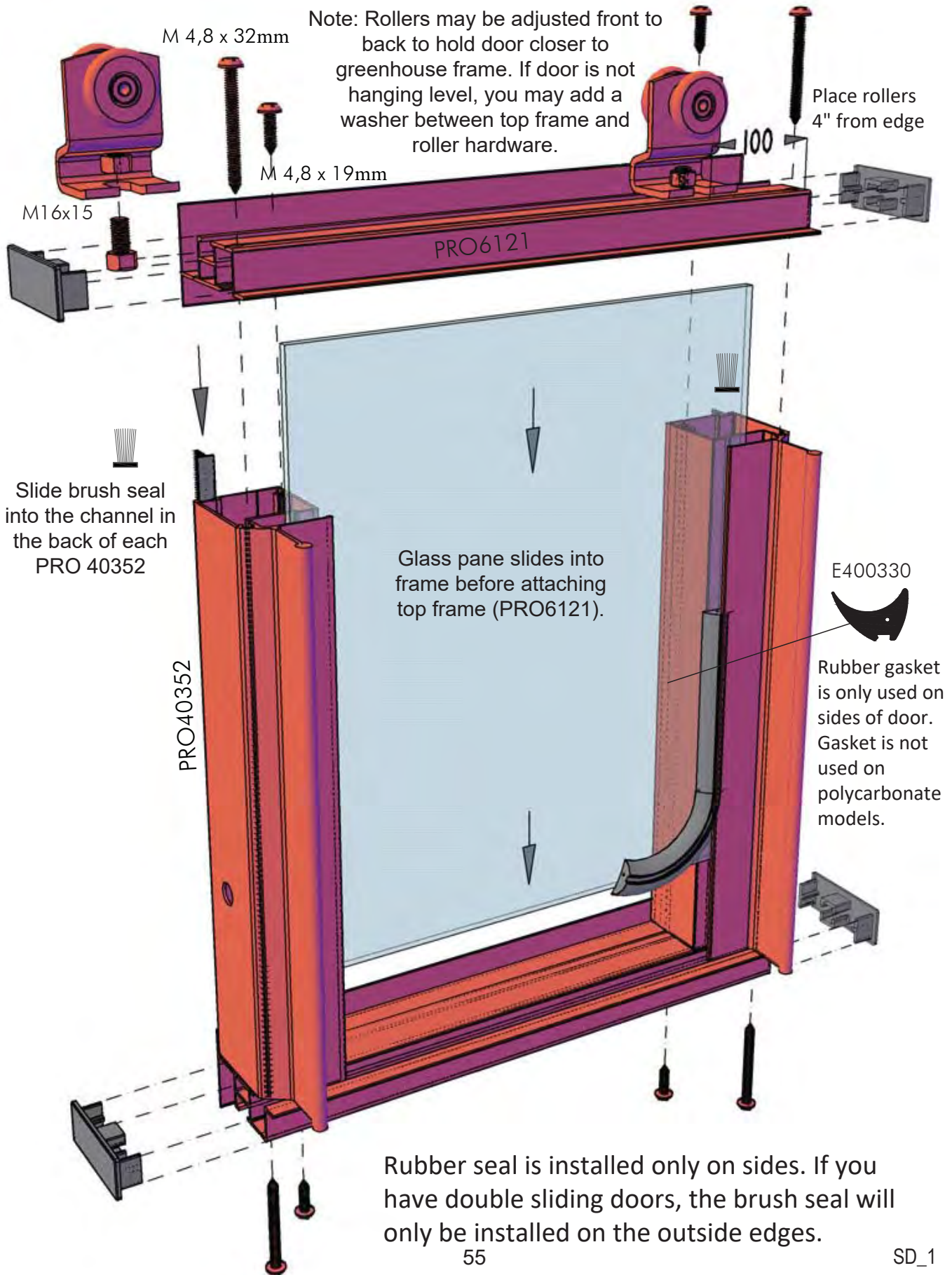

Sliding Door: Sliding door/s may be attached in any bay (with exceptions to corner placement)

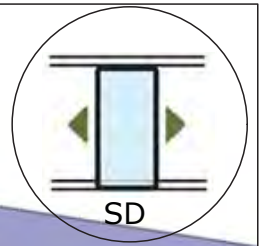

! **IMPORTANT for Double Sliding Door Opening!!** Cut one PRO7545 in half. Place long PRO7545 in center (to support double opening) and the half PRO7545 on either side. Do not cut PRO7545 if you have a stem wall (See p. 19).

1/2 1/2

↓ leave 1/2" space between ends of PRO7545 ↓

(Double door opening with no center post)

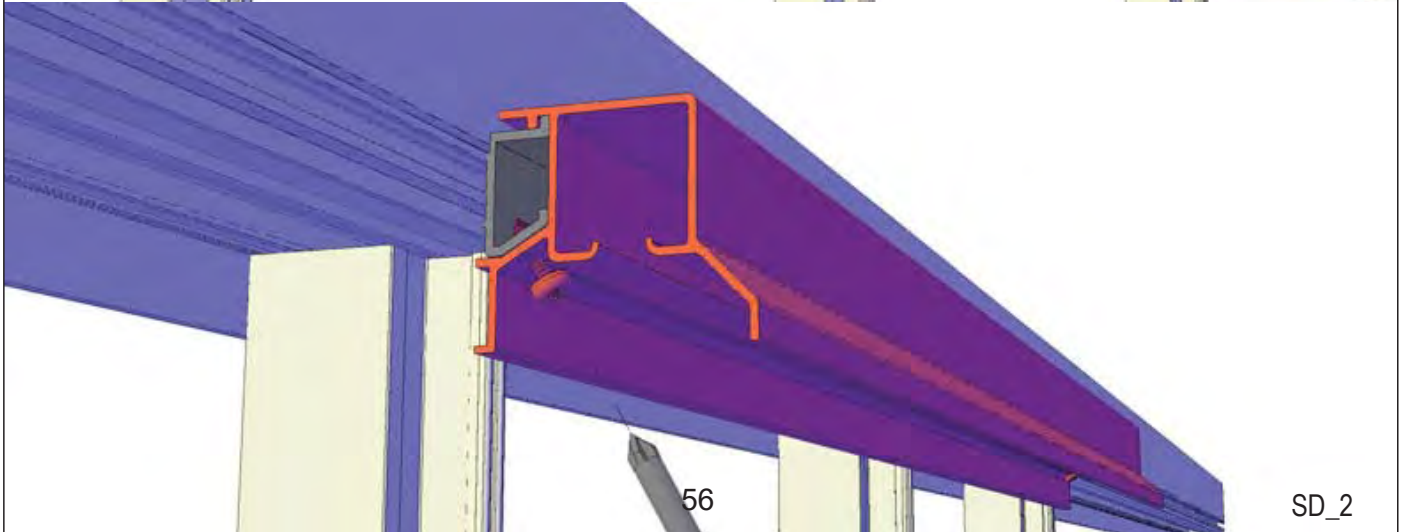
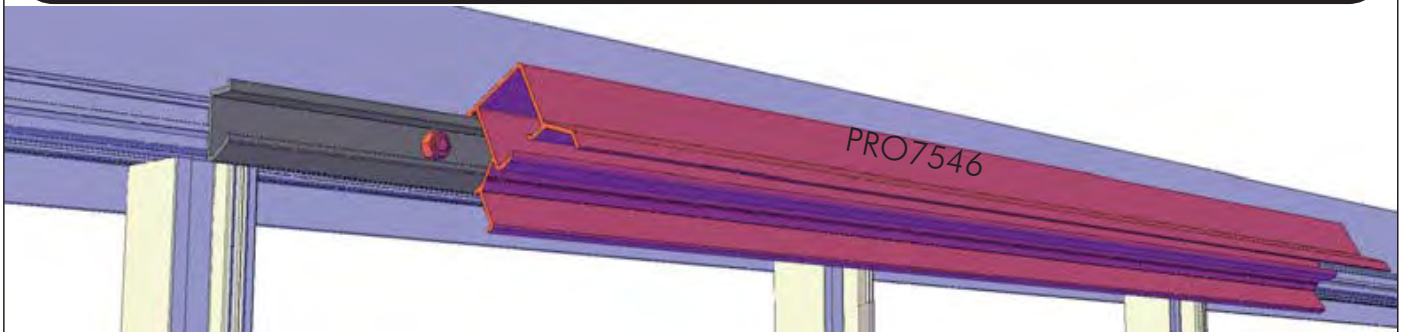

OPTION: Double Sliding Door

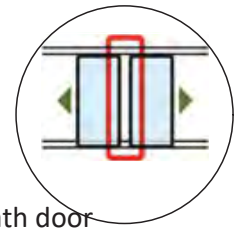

As needed, use washer underneath door hanger to level the door/s .

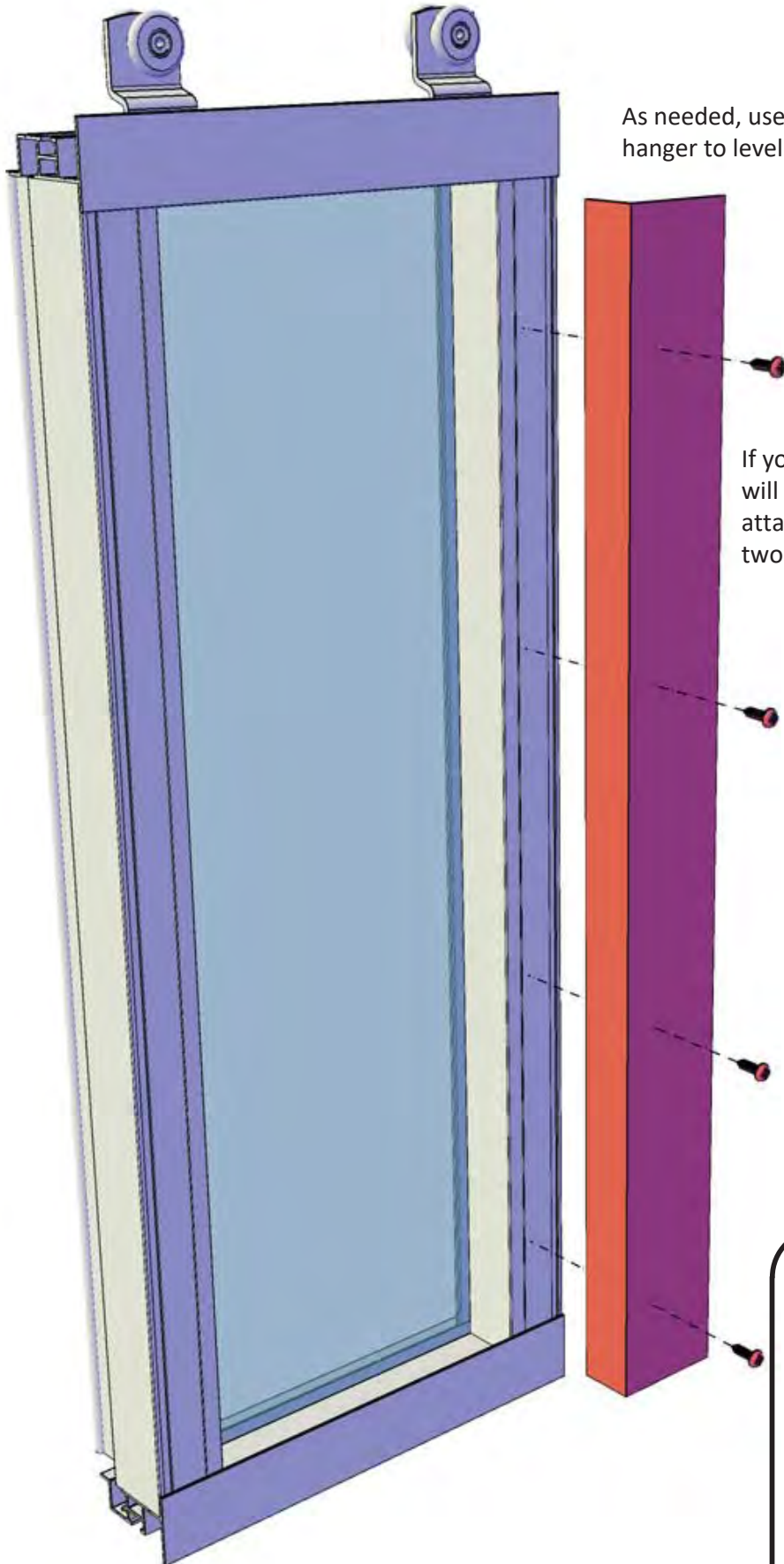

If you have a double sliding door, you will have a long L bracket that will attach to close any gap between the two doors.

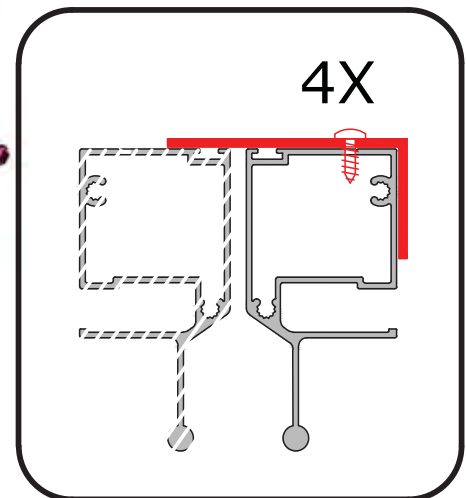

Slide door rollers into top door hanger (PRO7546 or PRO7876) and slide a stopper on either side. Determine how far the door should slide, then tighten the screw on the bottom of the stopper to secure. Finish with door hanger caps.

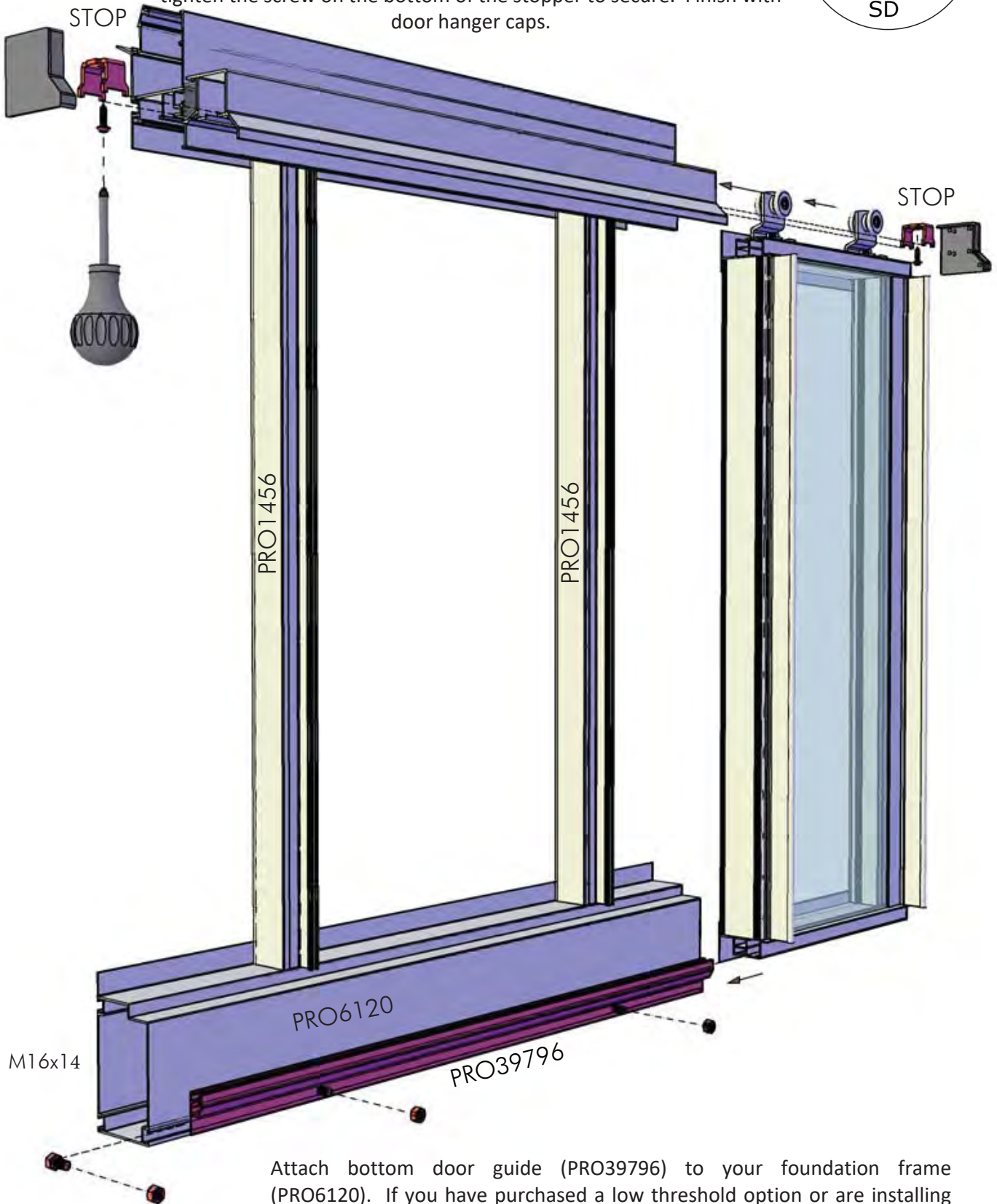
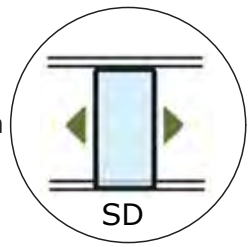

Attach bottom door guide (PRO39796) to your foundation frame (PRO6120). If you have purchased a low threshold option or are installing your greenhouse on a wall, please refer to the following pages marked SD_MUR for stem wall and KSD for low threshold kit before installing door, bottom door guide, and locks.

Sliding Door Lock (w/o low threshold kit)



Install lock at bottom of a: - single sliding door
- first door of double sliding doors
- both of your double sliding doors

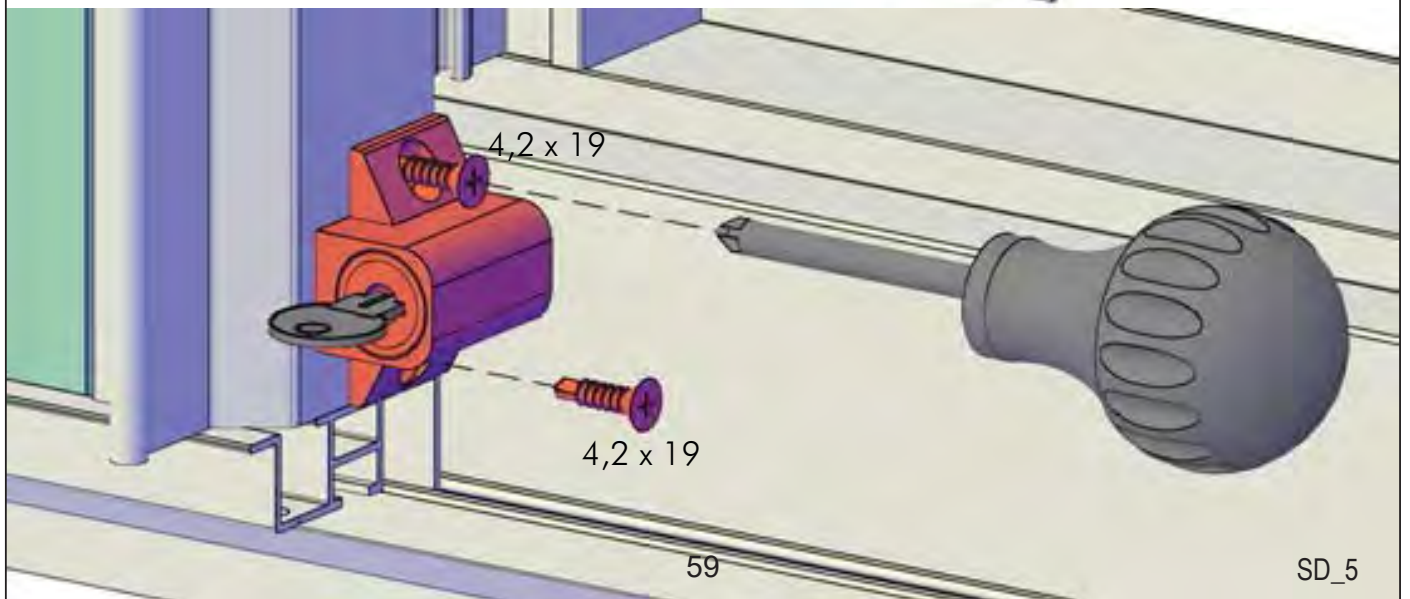
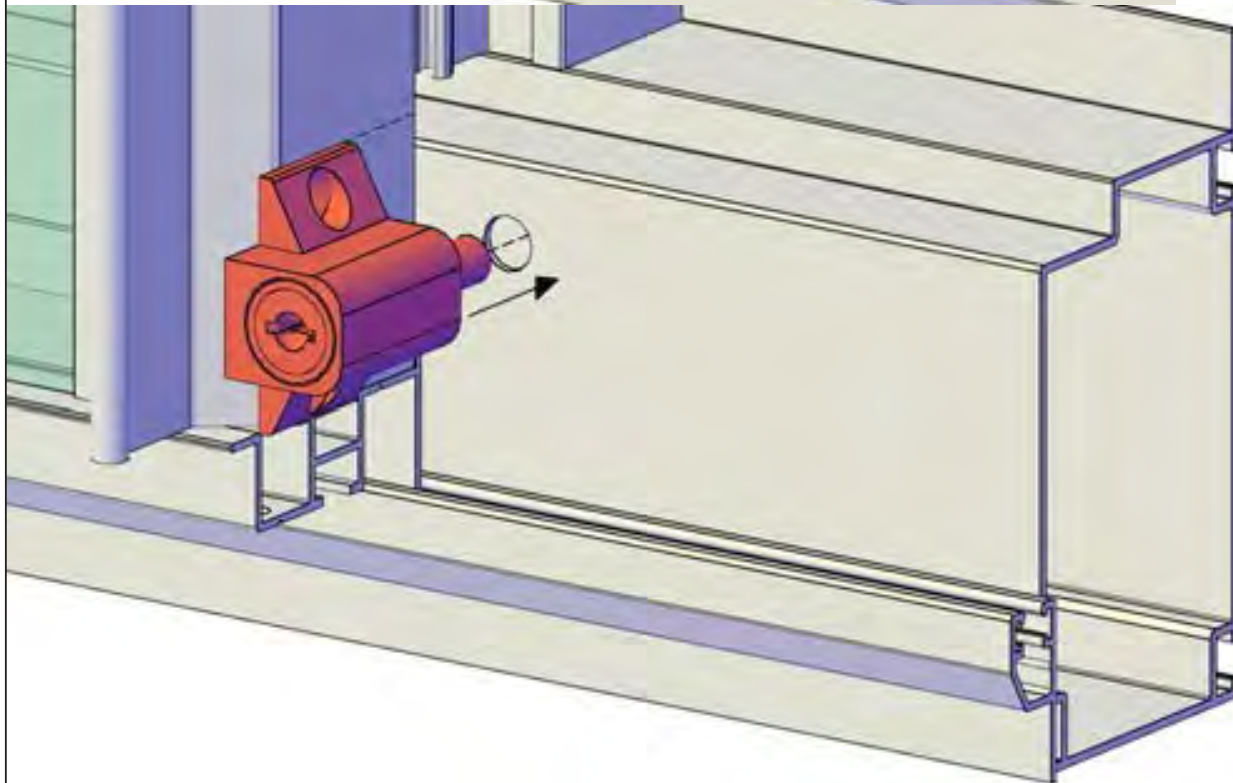
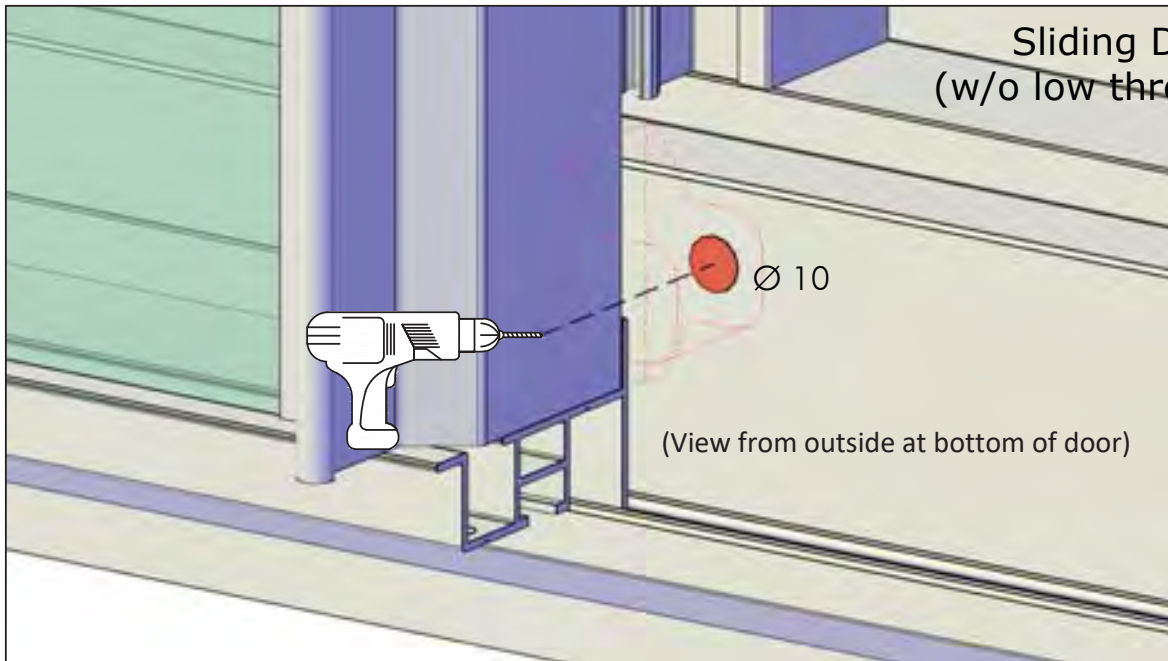

(View from inside at top of door)

Double Sliding Door Lock (w/o low threshold kit)



If you have a double sliding door, you may install one lock on the inside of your greenhouse as shown

Ø 10

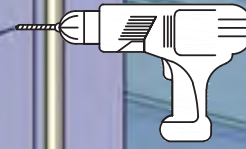

4,2 x 19



4,2 x 19

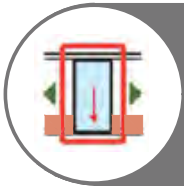

OPTION: Greenhouse on a stem/knee wall

SD_MUR

KSD_70

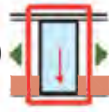

Single sliding door opening should be 703mm



KSD_144

Double sliding door opening should be 1441mm

Cut foundation frame 17mm from bolt hole

Cut foundation frame 17mm from bolt hole

703

1441

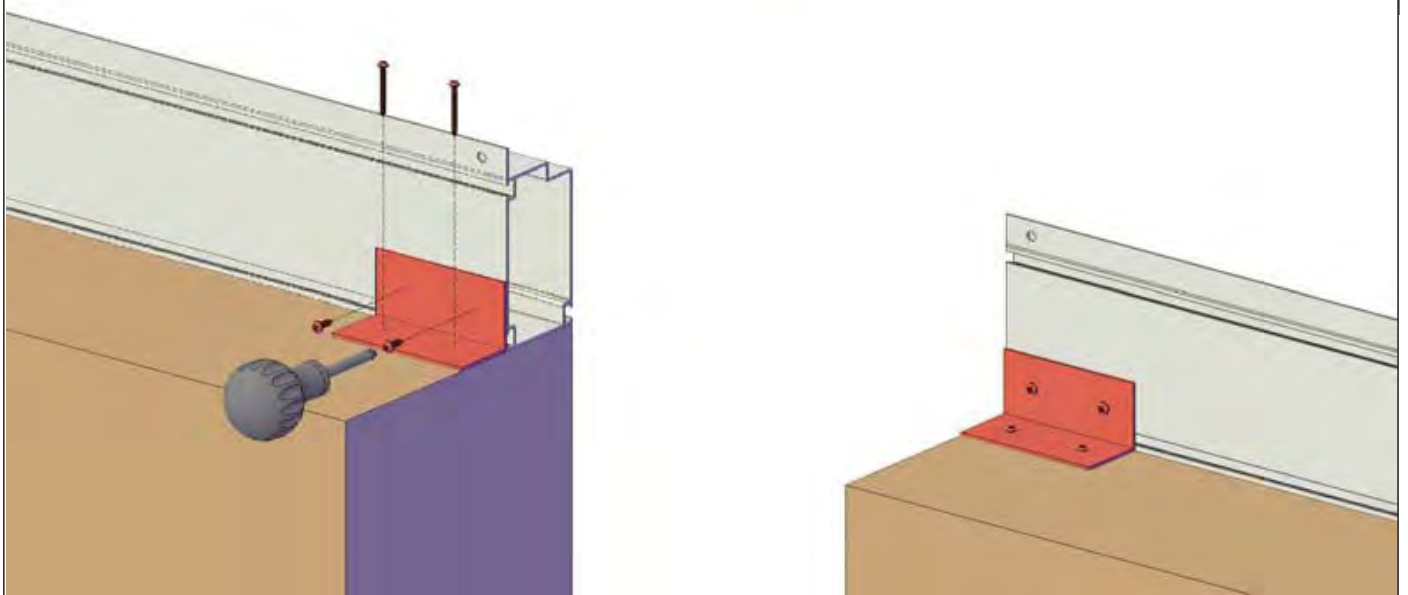
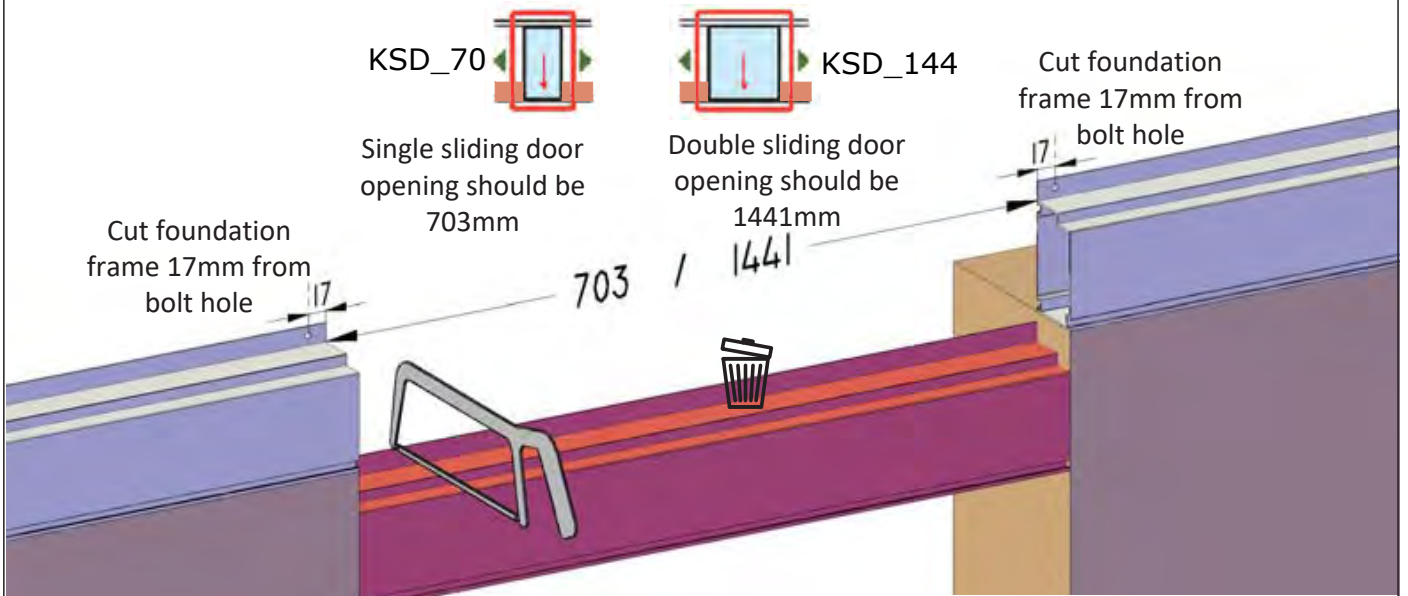

ALTERNATIVE

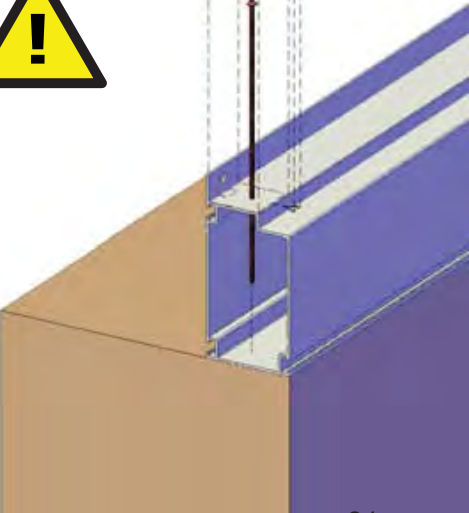
(hardware not included)



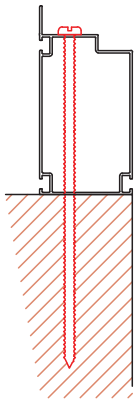

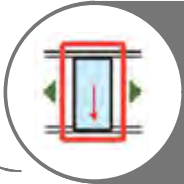
OPTIONAL UPGRADE: Fall 2022 Low Threshold for Sliding Door/s

KSD

KSD_70



Single sliding door opening
should be 703mm

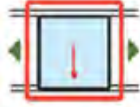

KSD_144

Double sliding door opening
should be 1441mm

Cut foundation
frame 17mm from
bolt hole

Cut foundation
frame 17mm from
bolt hole

703 / 1441

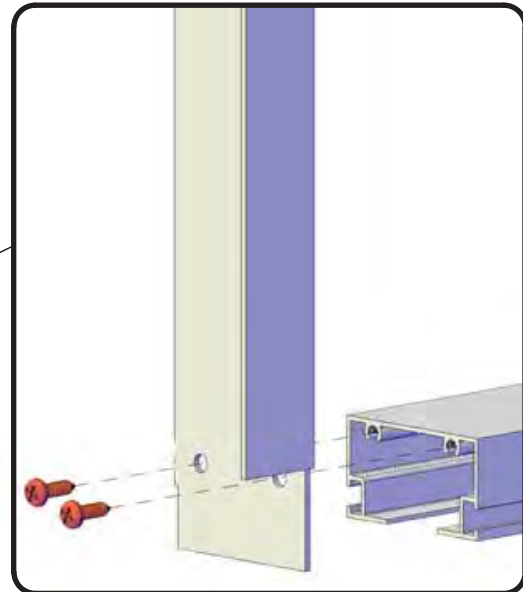
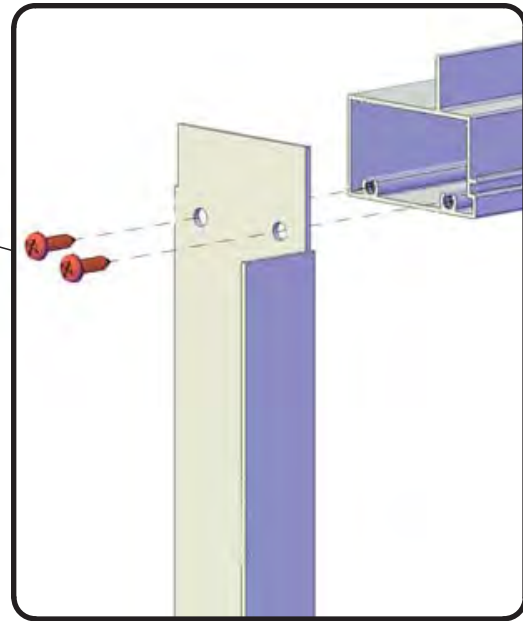
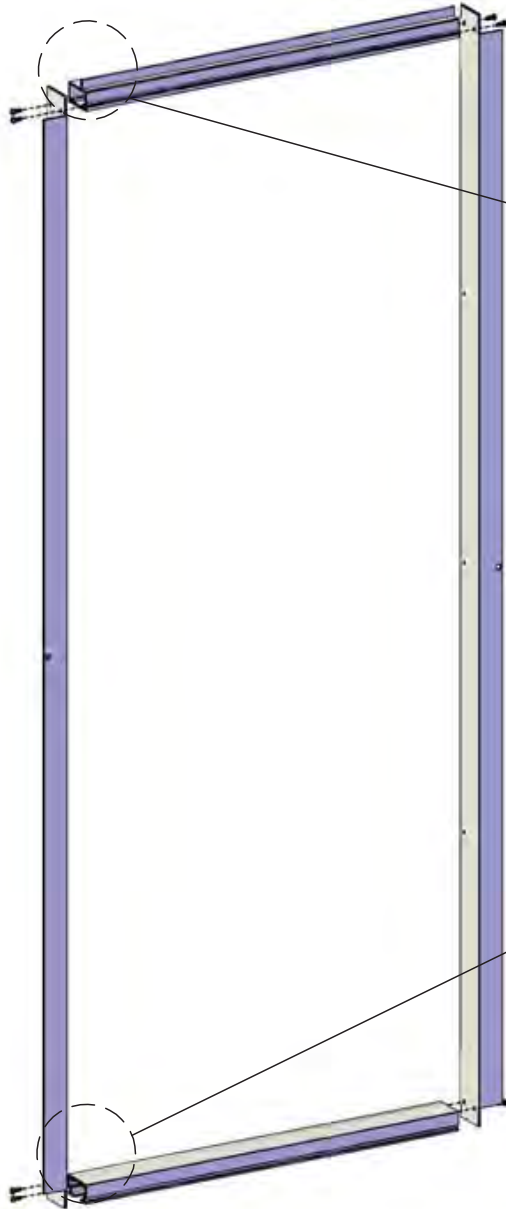
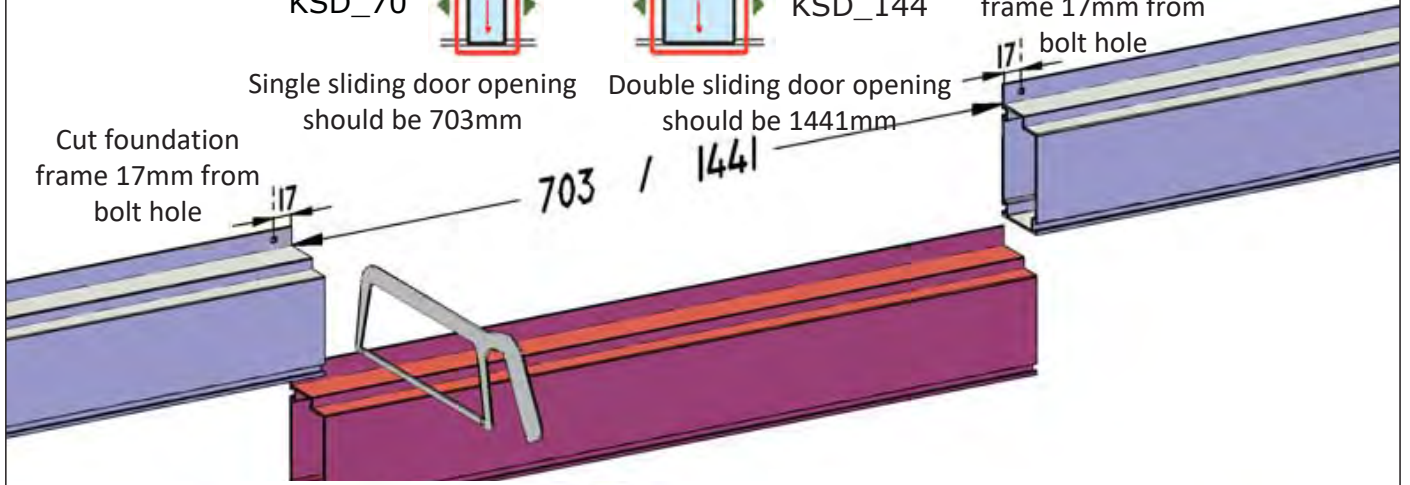

KSD_1

OPTIONAL UPGRADE: Fall 2022 - Low Threshold for Sliding Door/s

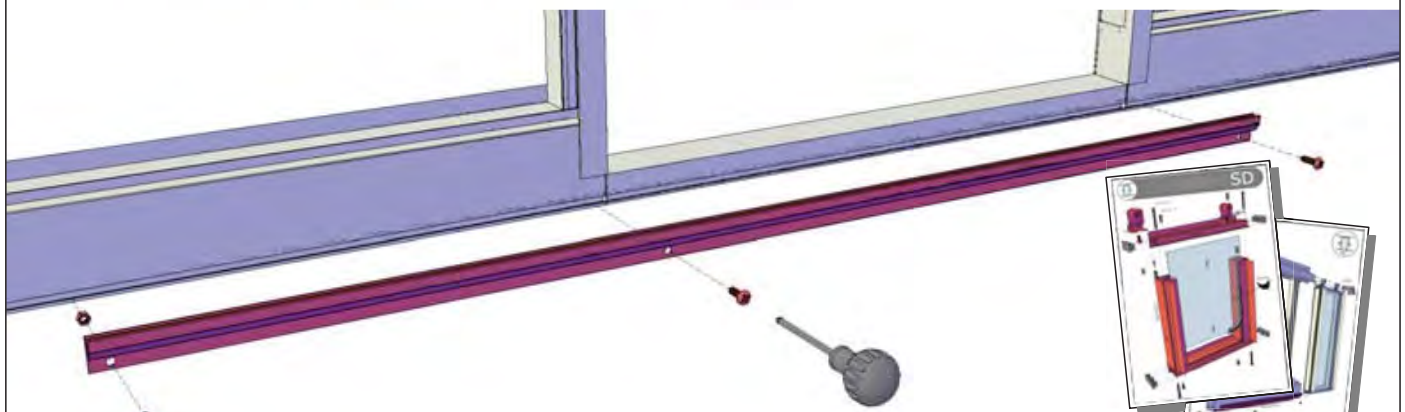
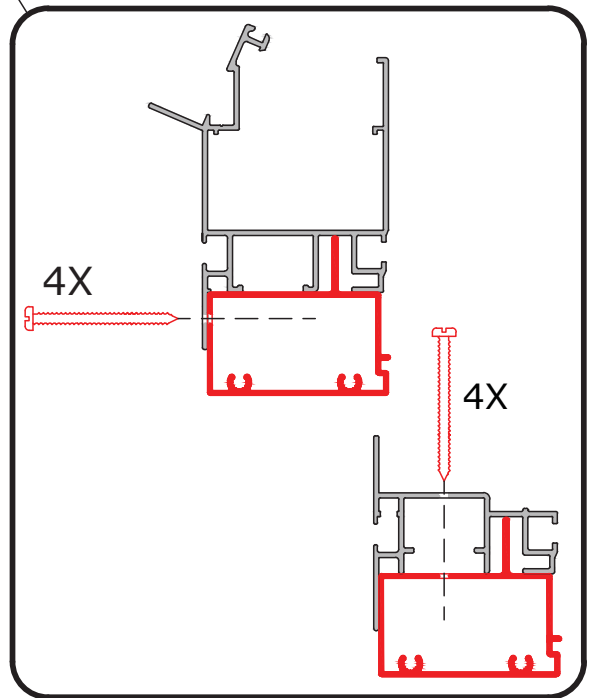
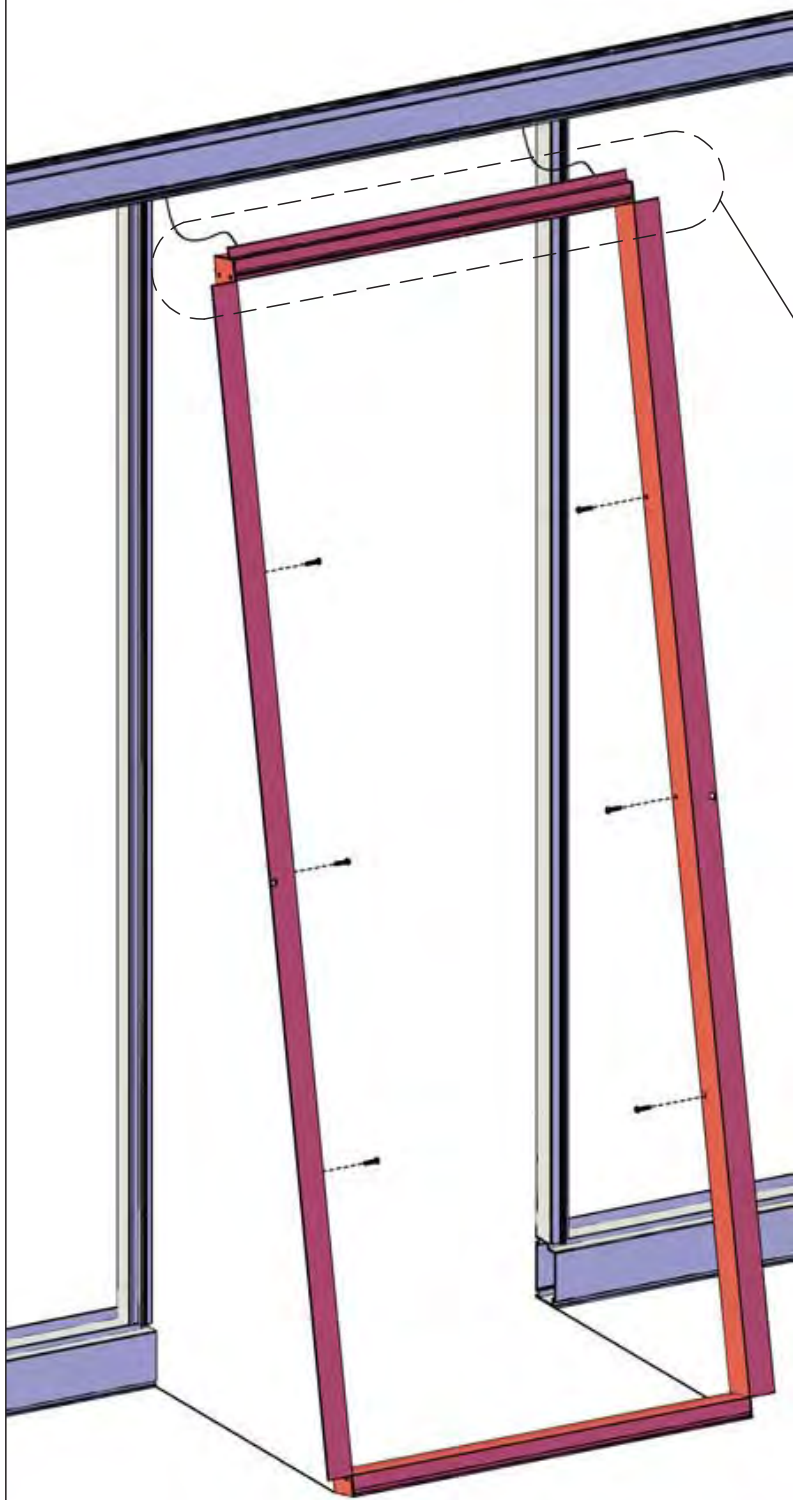

Optional Upgrade: Lock installation with Low Threshold

Kit

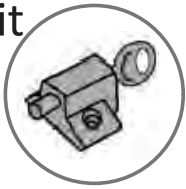

KSD_70

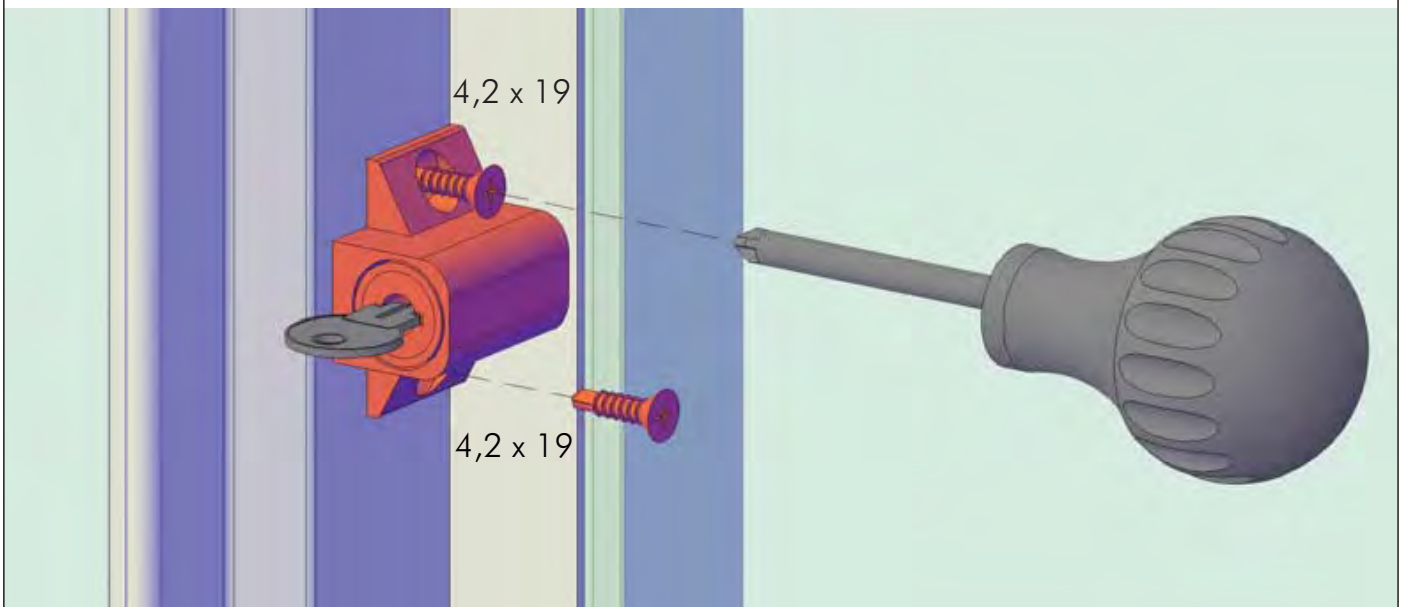
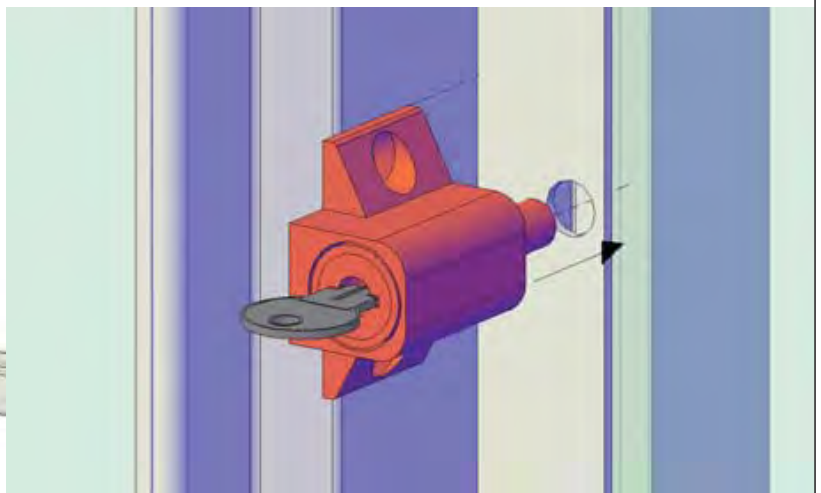
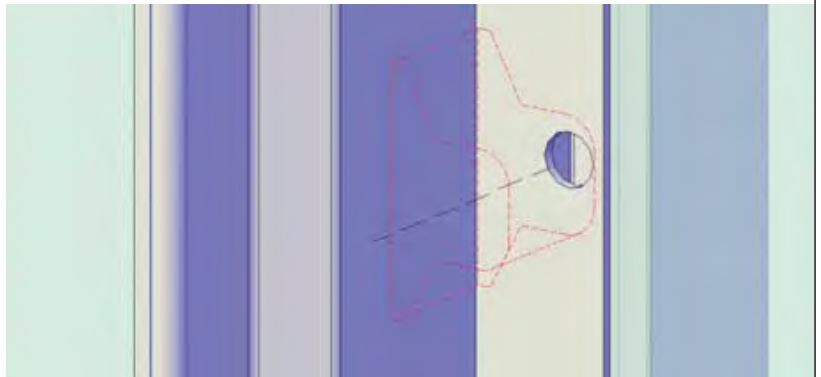
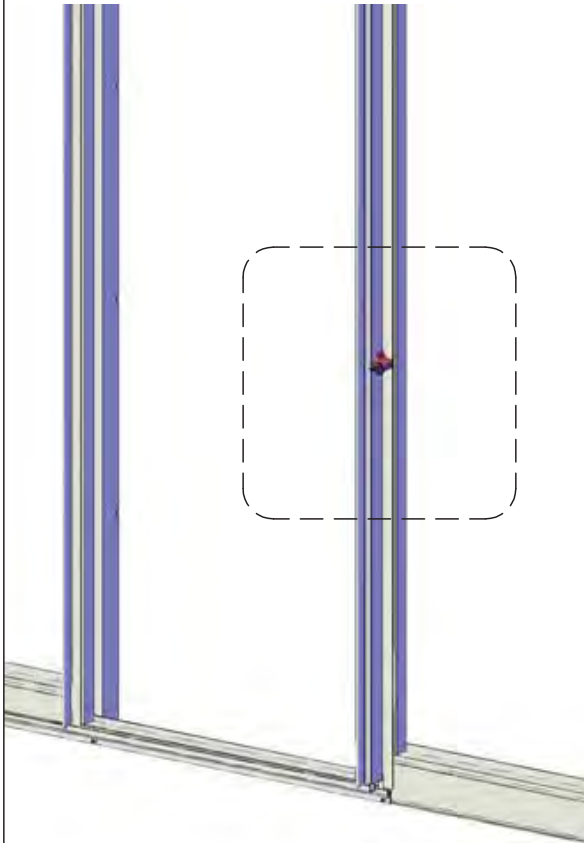
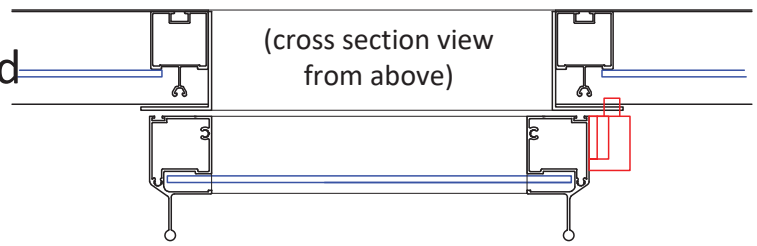

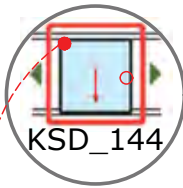
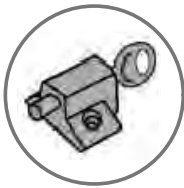

KSD_144

Optional Upgrade: Lock installation with Low Threshold Kit (Double Sliding Door - installed on the inside on one door)

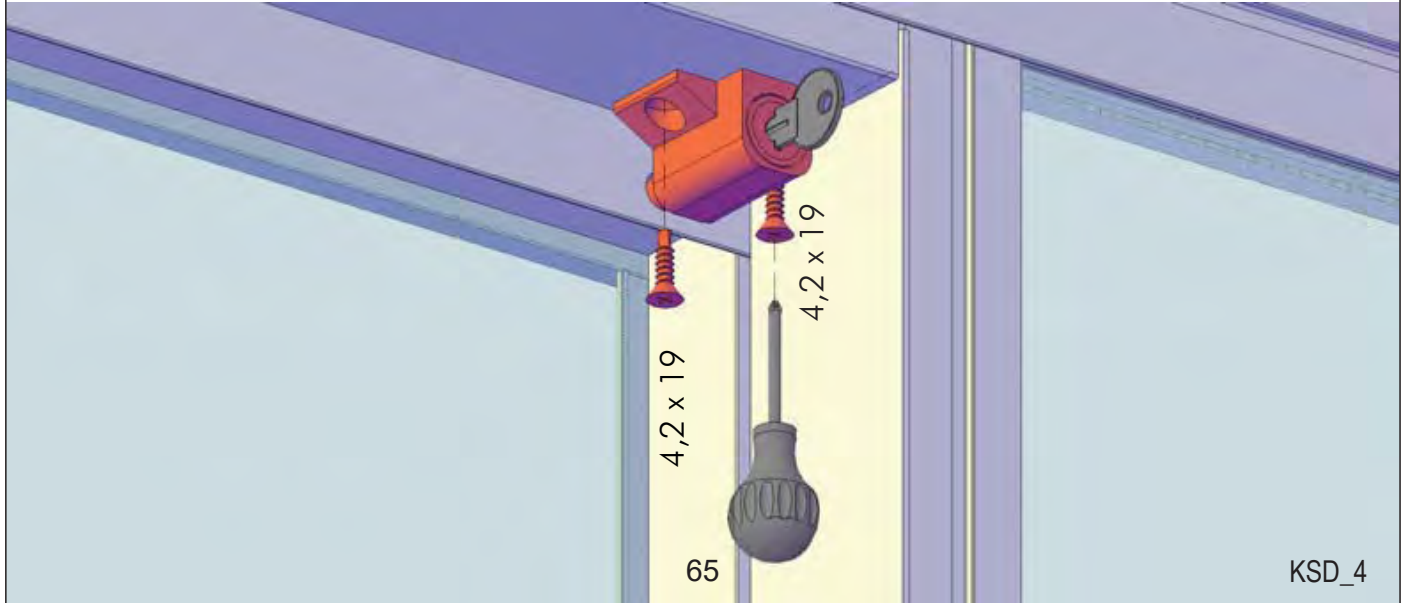
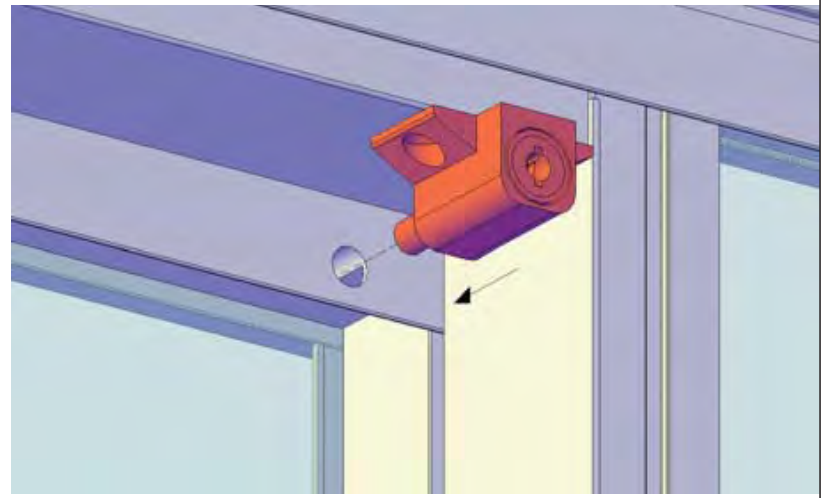
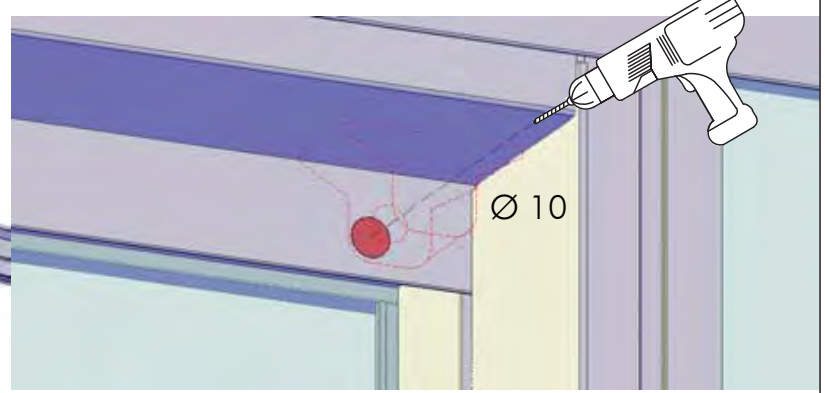
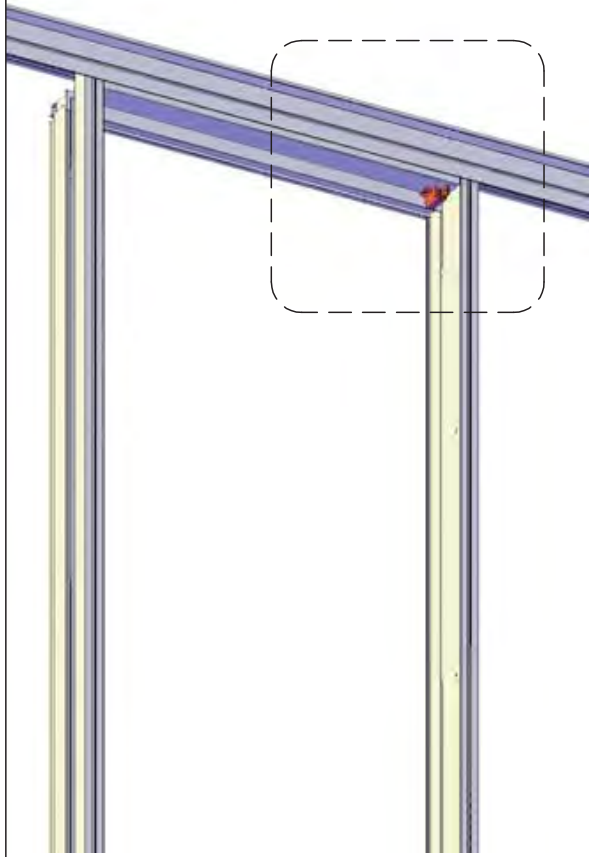
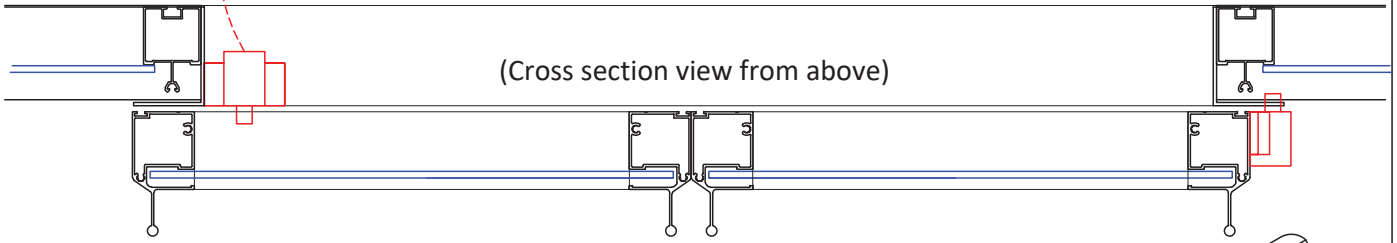

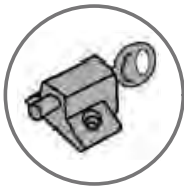

Optional Upgrade: Lock installation with Low Threshold Kit (Double Sliding Door - installed on the exterior for other door)

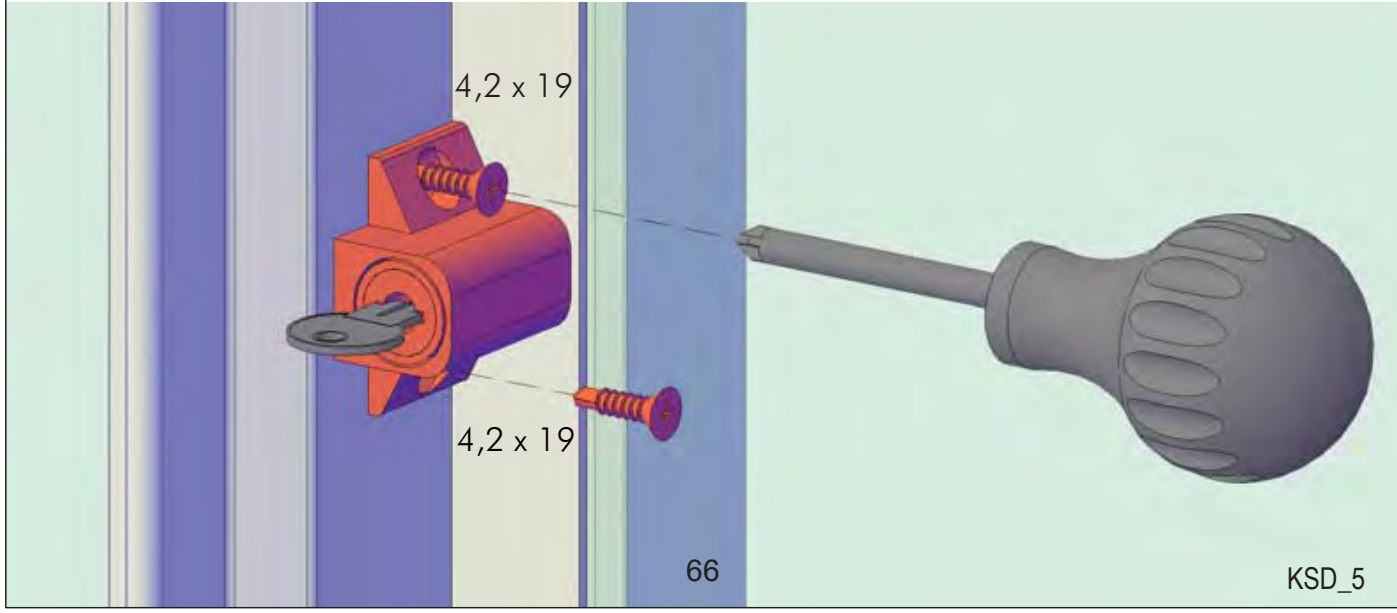
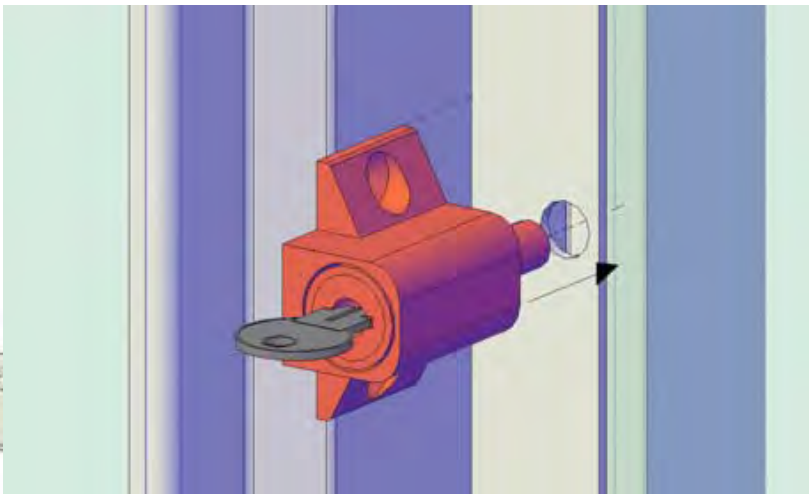
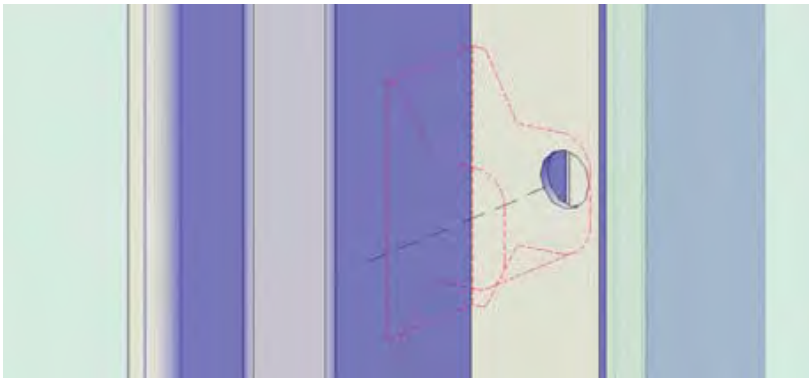
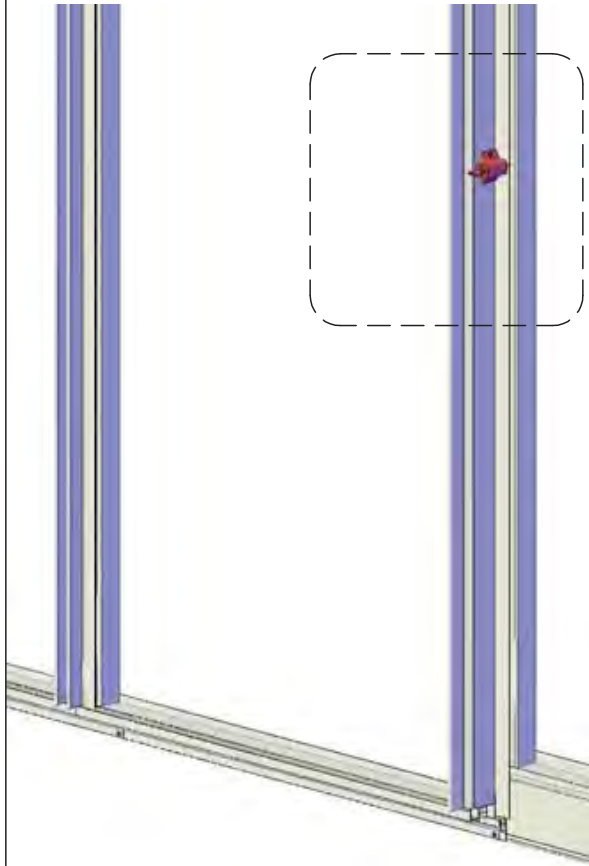
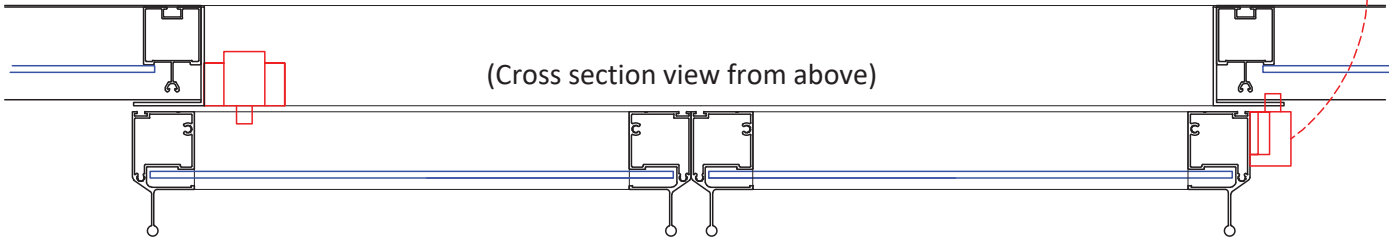
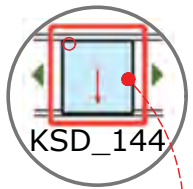

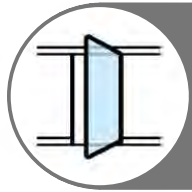

OPTIONAL UPGRADE: Hinged Door

HD



IMPORTANT: Find Janssens Accessory installation video on our site here:

<https://www.exaco.com/greenhouse-victorian.php>

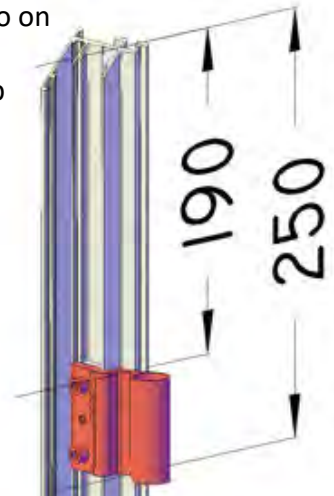
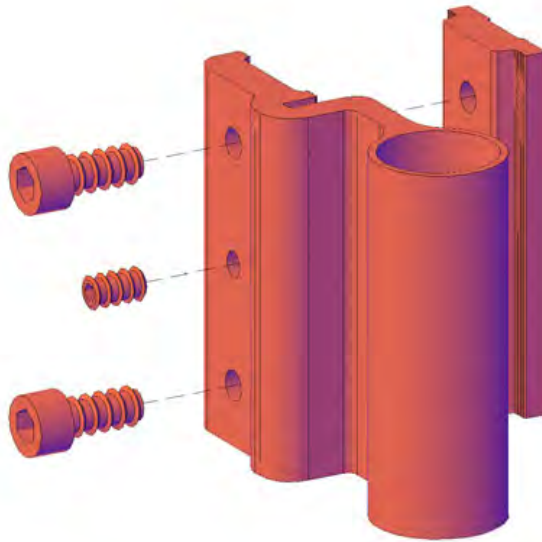



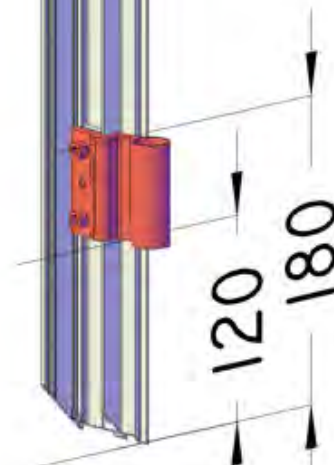
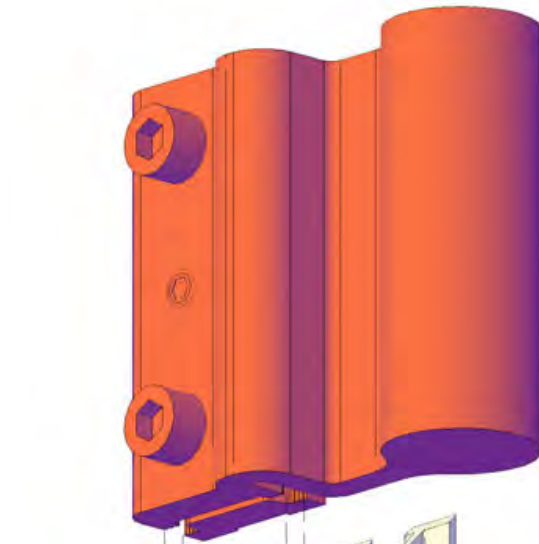
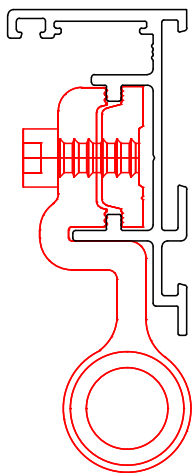

Hinges in door jamb will need to be adjusted.
Distances are in millimeters.

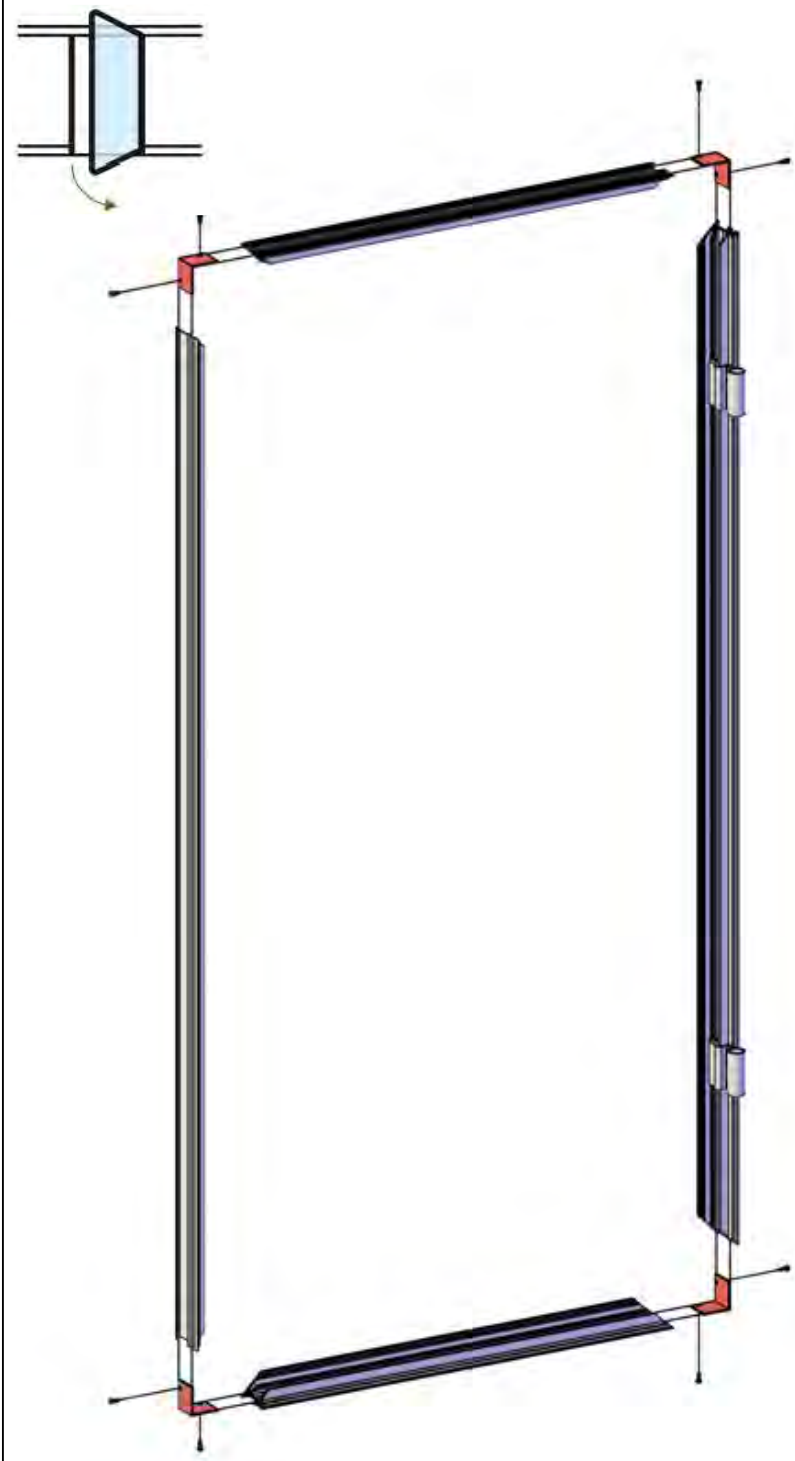

HD 1

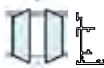

	ITEM	PC.	L
	L 40X40	4 PC	36 MM
	PRO6280	2 PC	703 MM
	PRO6280	2 PC	1.441 MM
	PRO6280	2 PC	1.930 MM
	4,2 x 13	8 PC	

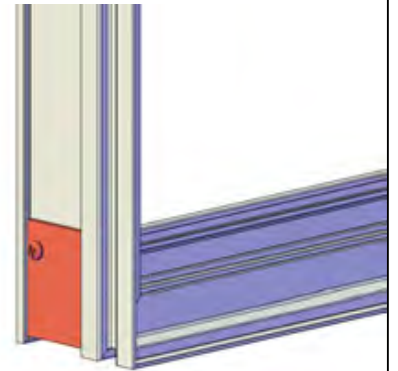
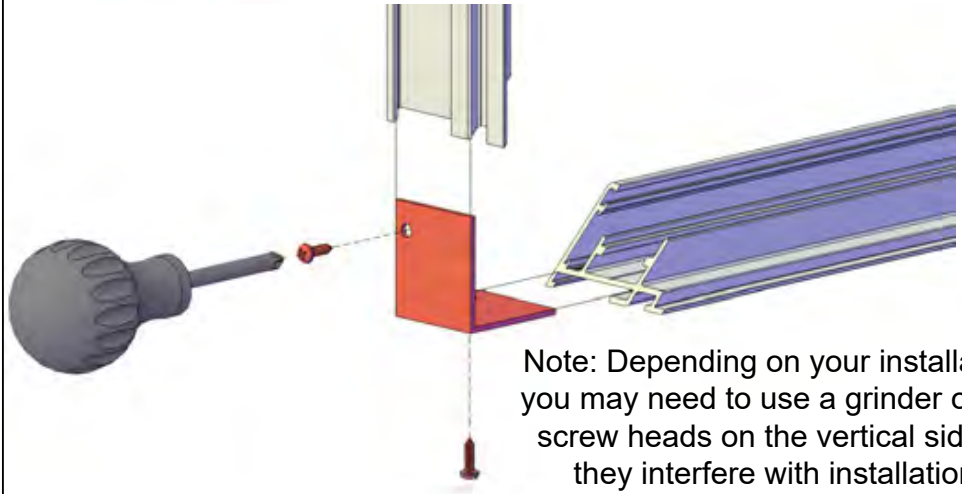
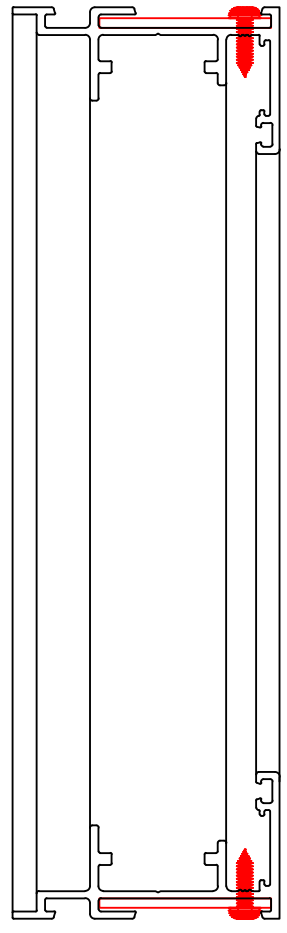

Note: Depending on your installation, you may need to use a grinder on the screw heads on the vertical sides if they interfere with installation.

Double Hinged door will need opening of 1441mm, 17mm from bolt holes on foundation frame.

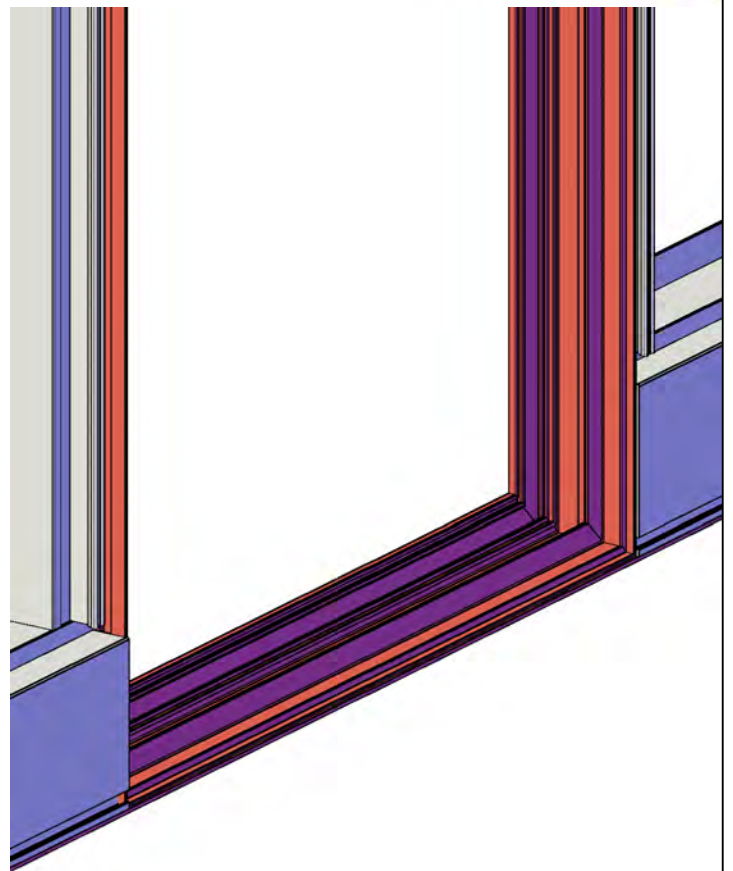
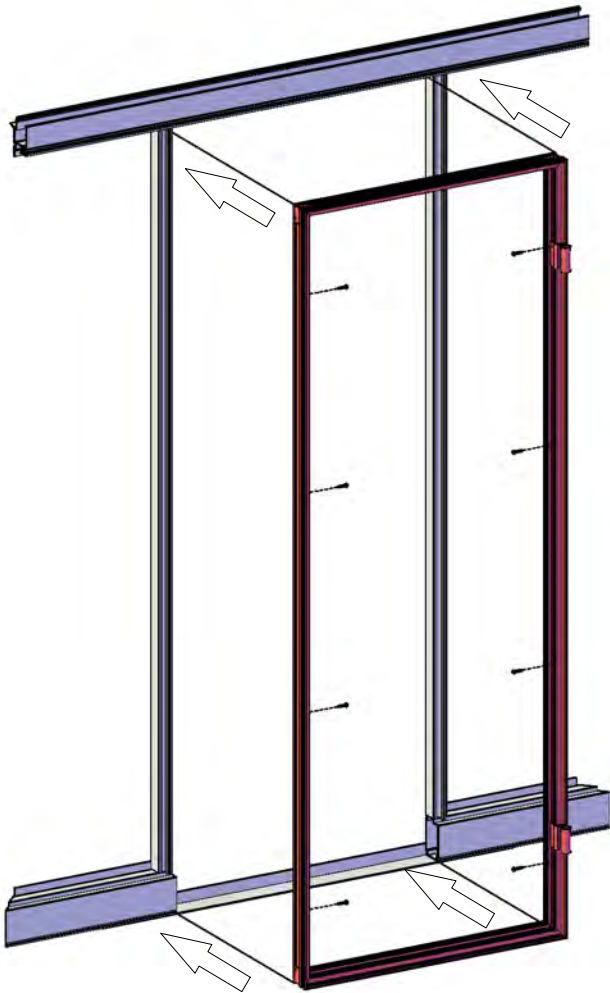
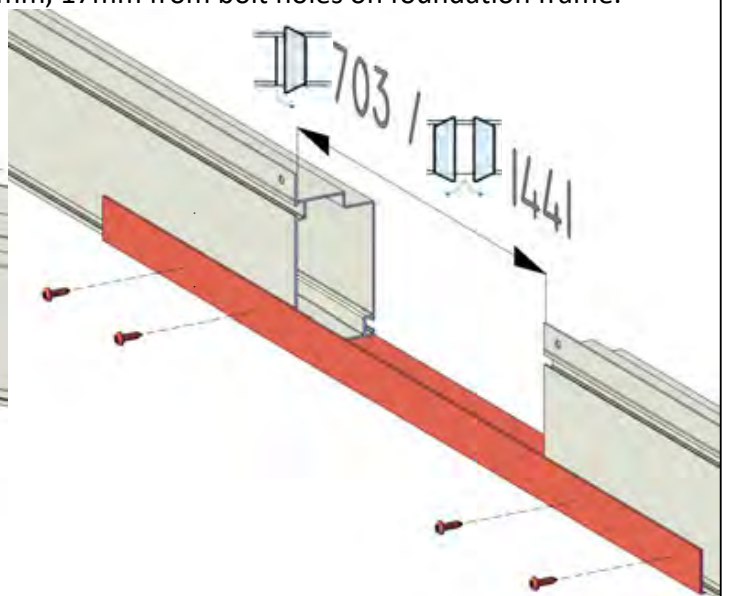
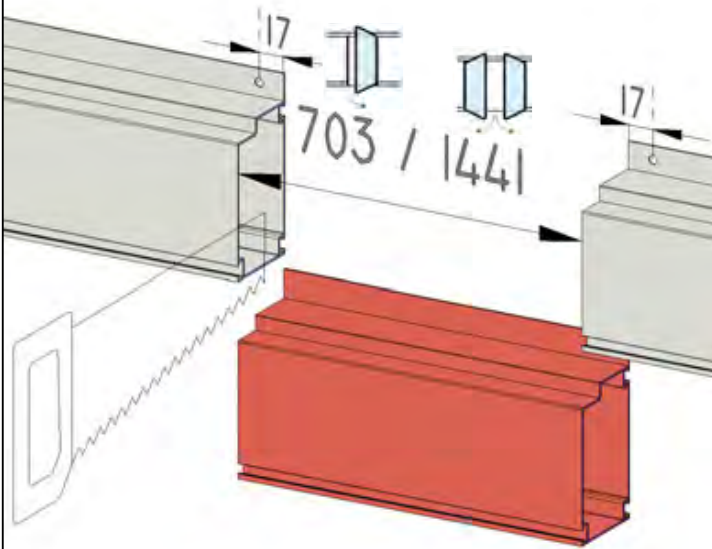

(Single door shown, double door jamb installation will be identical)

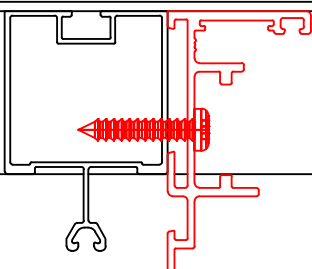

(view from top)

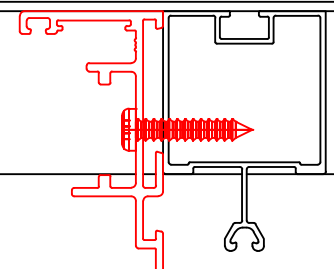

HD 3

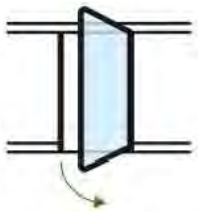

Single hinged door

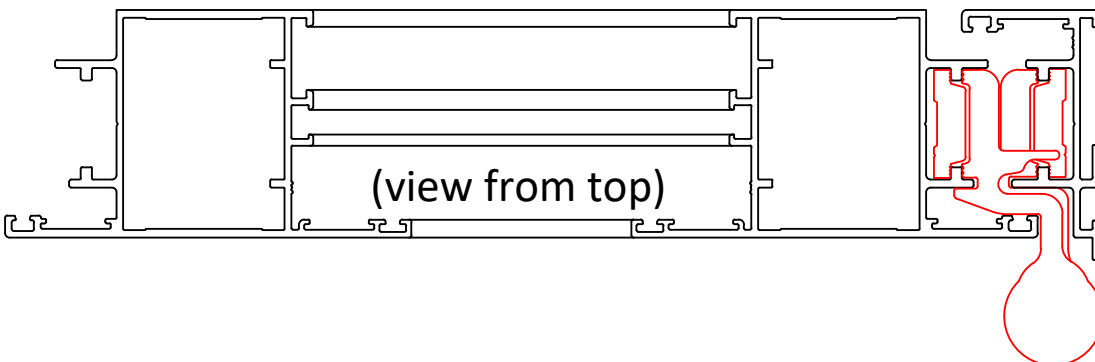
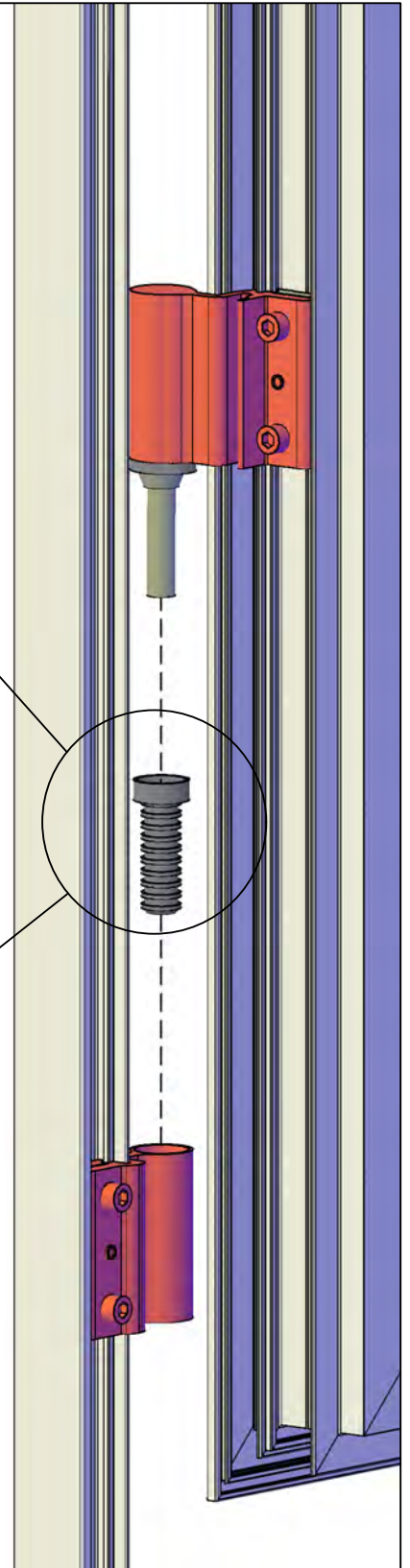
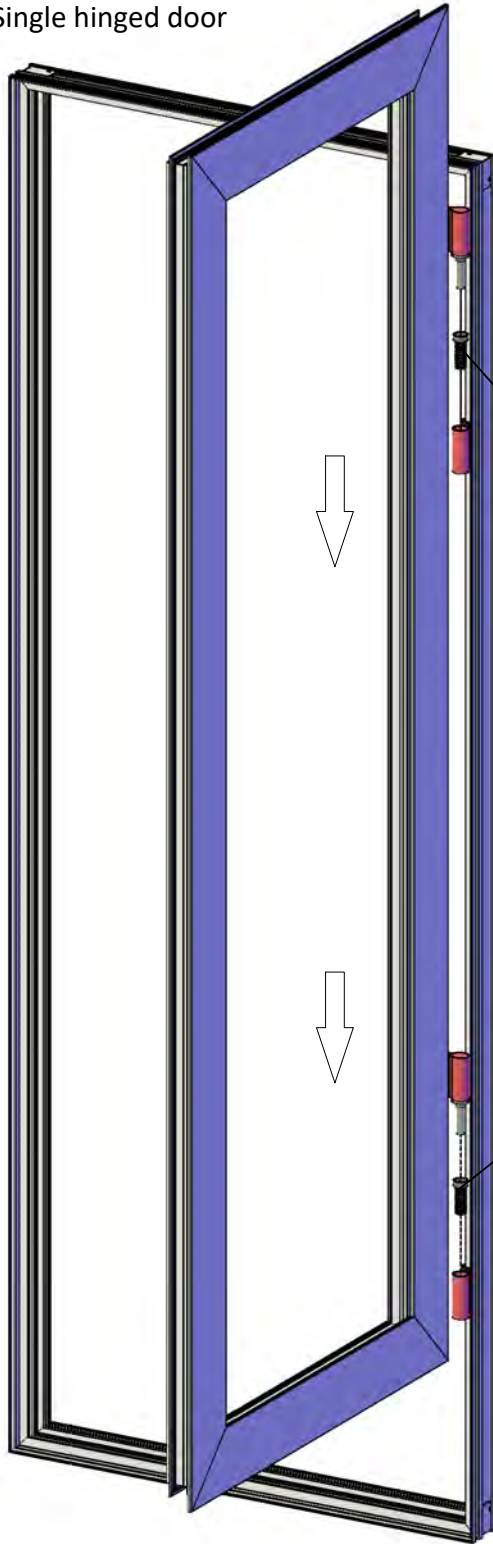

HD 4

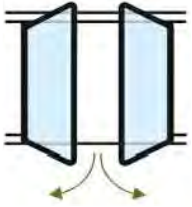

OPTION: Double Hinged Door

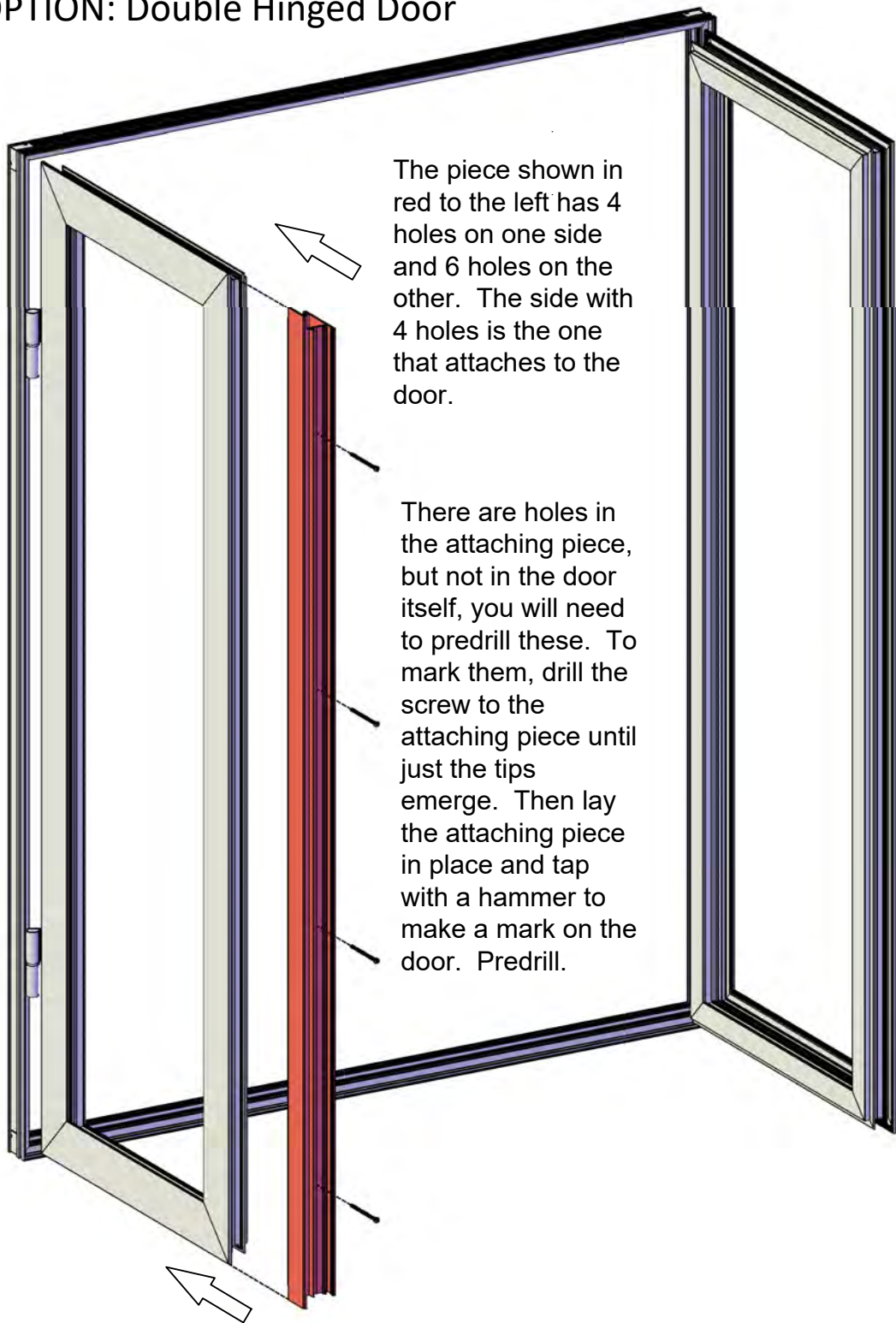

The piece shown in red to the left has 4 holes on one side and 6 holes on the other. The side with 4 holes is the one that attaches to the door.

There are holes in the attaching piece, but not in the door itself, you will need to predrill these. To mark them, drill the screw to the attaching piece until just the tips emerge. Then lay the attaching piece in place and tap with a hammer to make a mark on the door. Predrill.

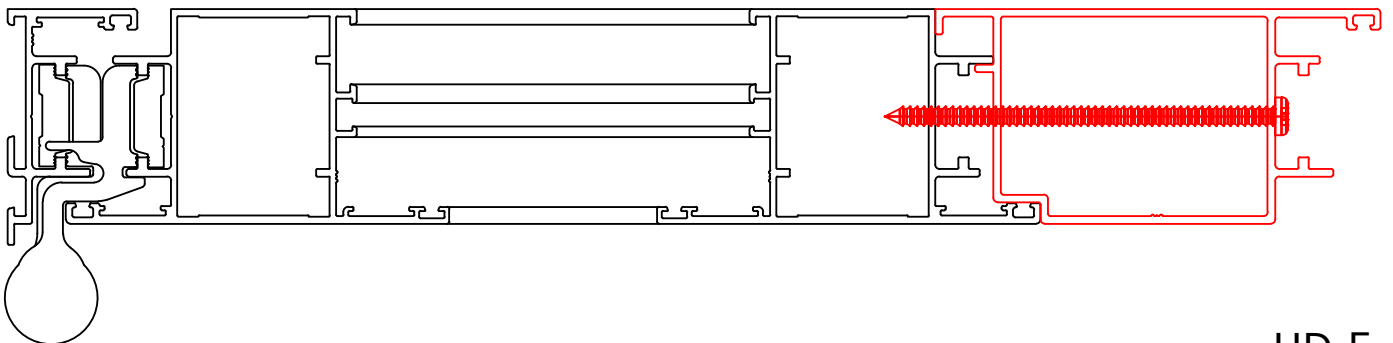

HD 5

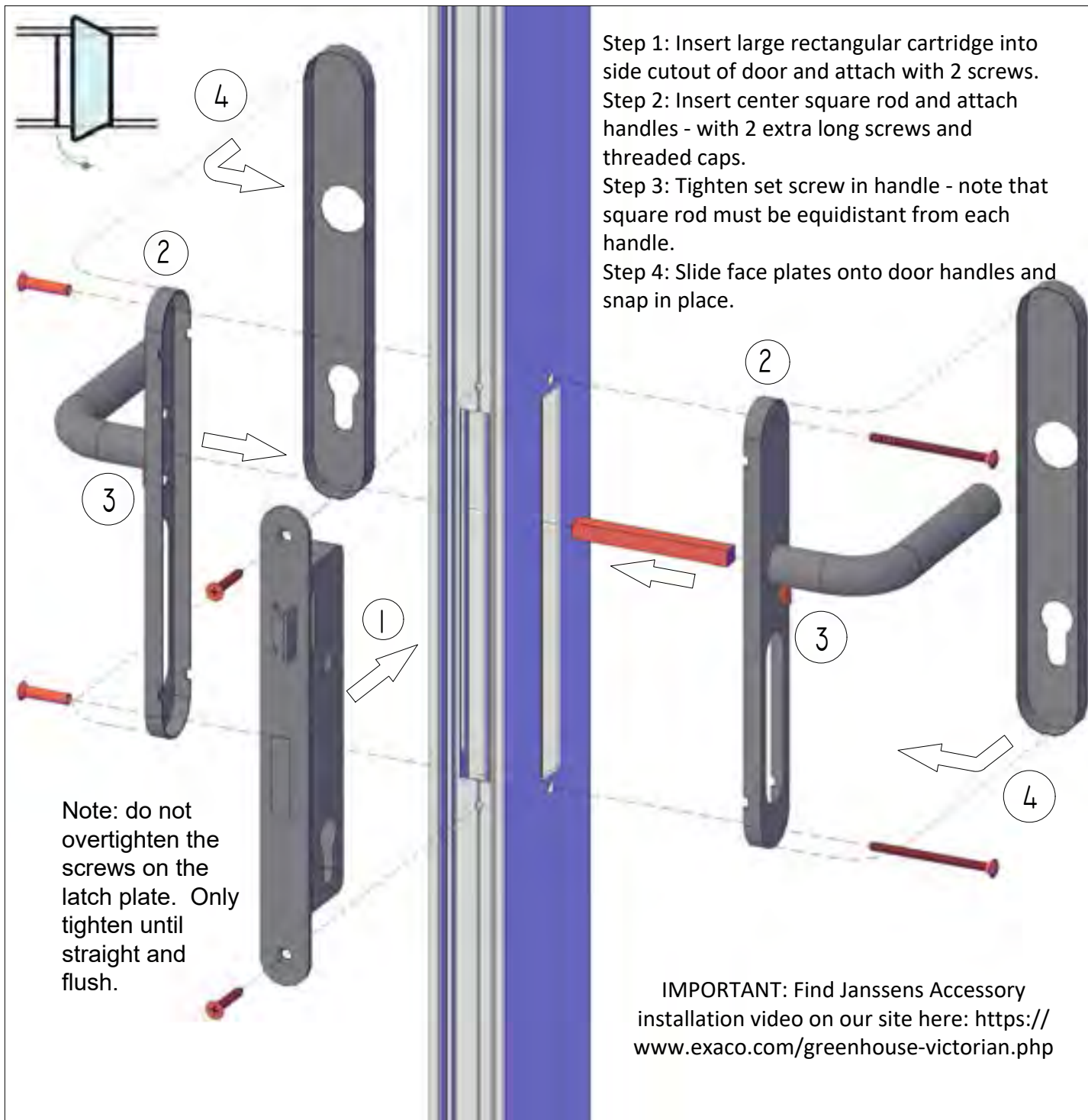

HD 6

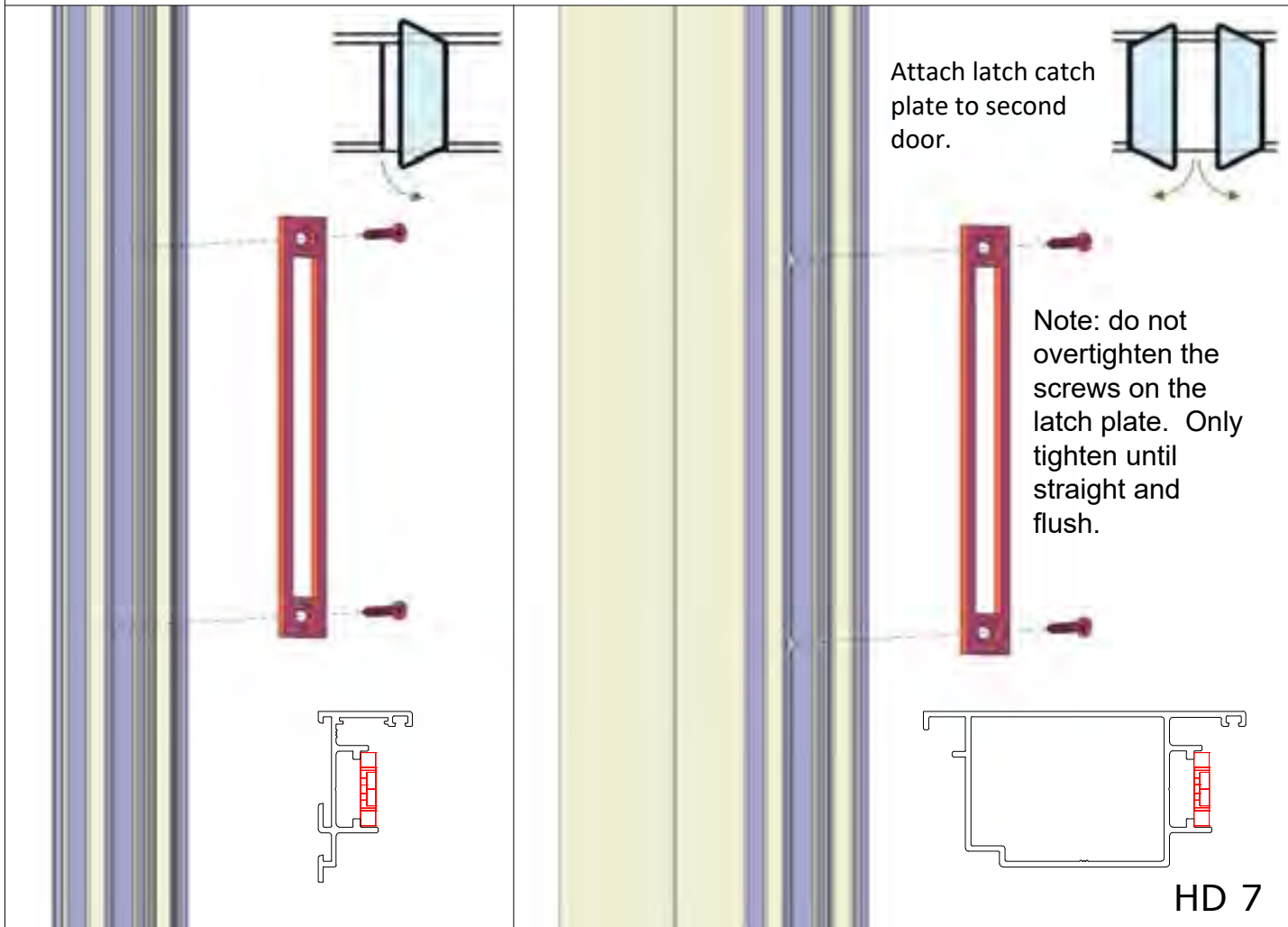
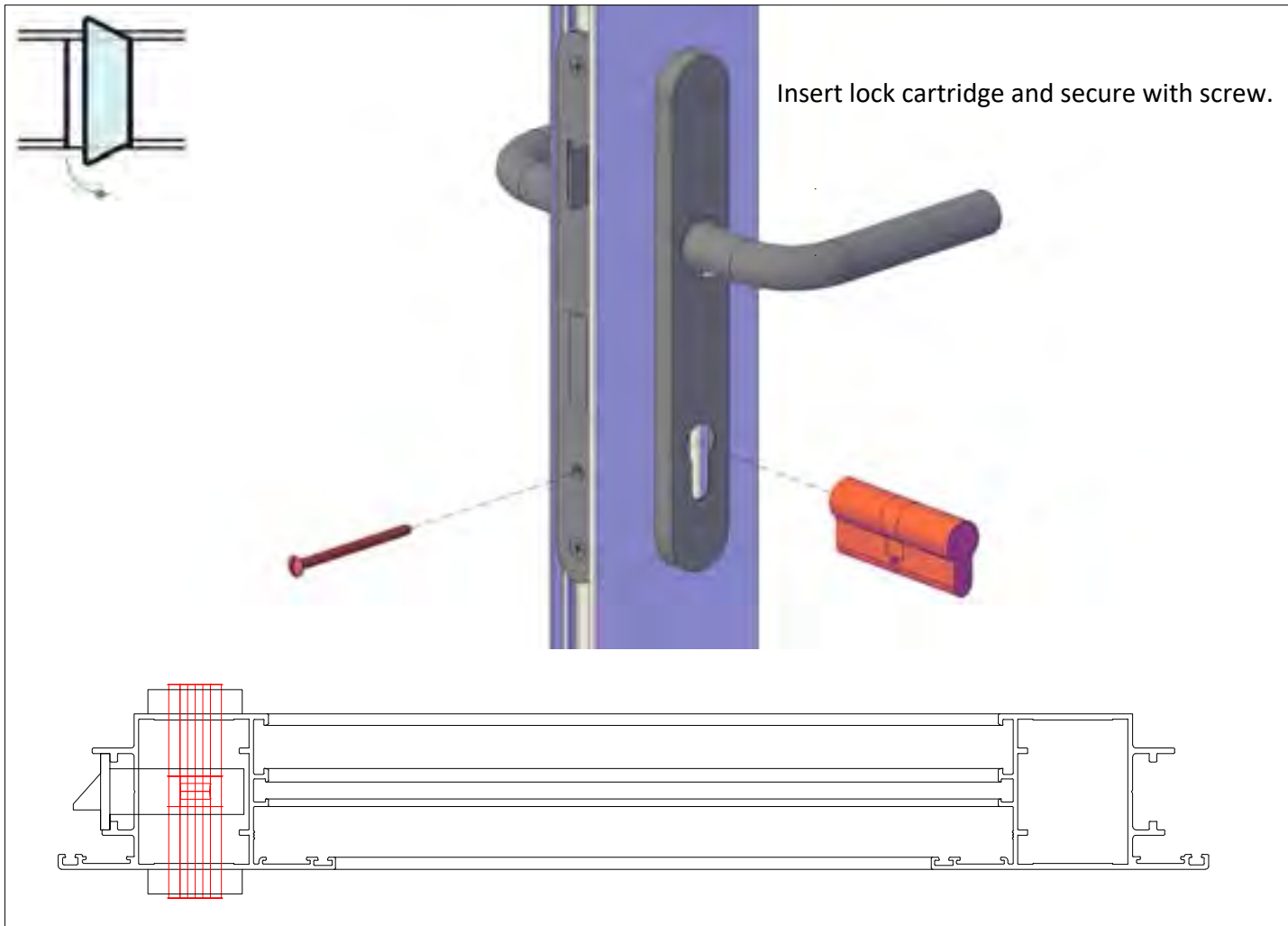

HD 7

For the next step, we recommend placing the door flat until glass is installed.

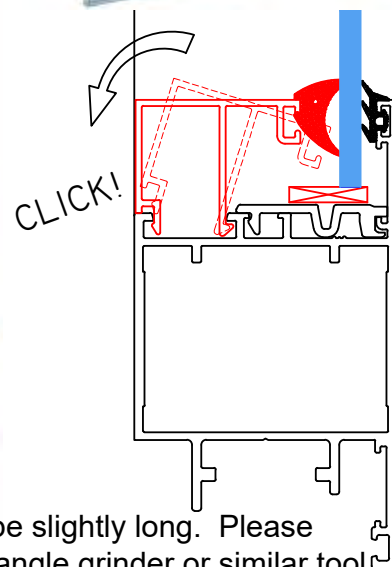
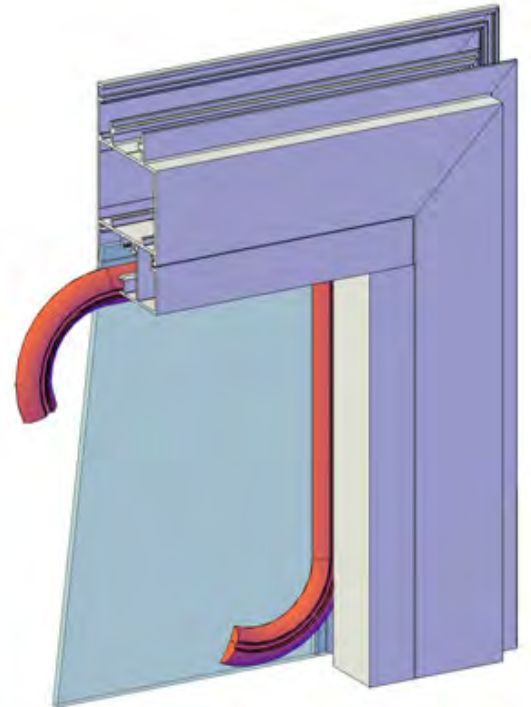
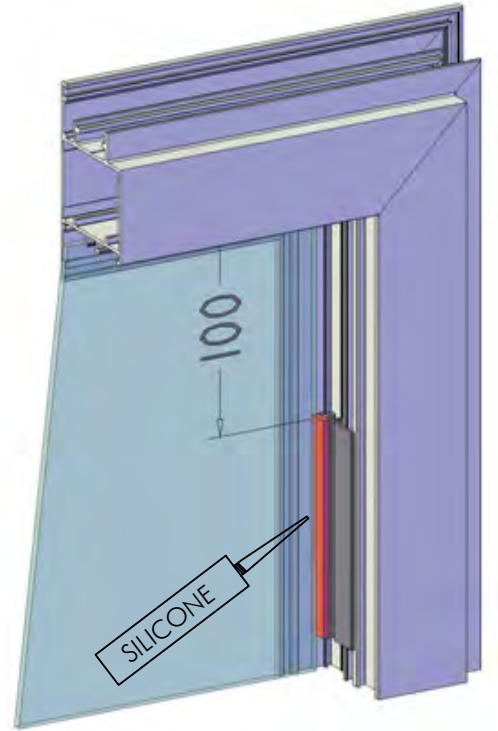
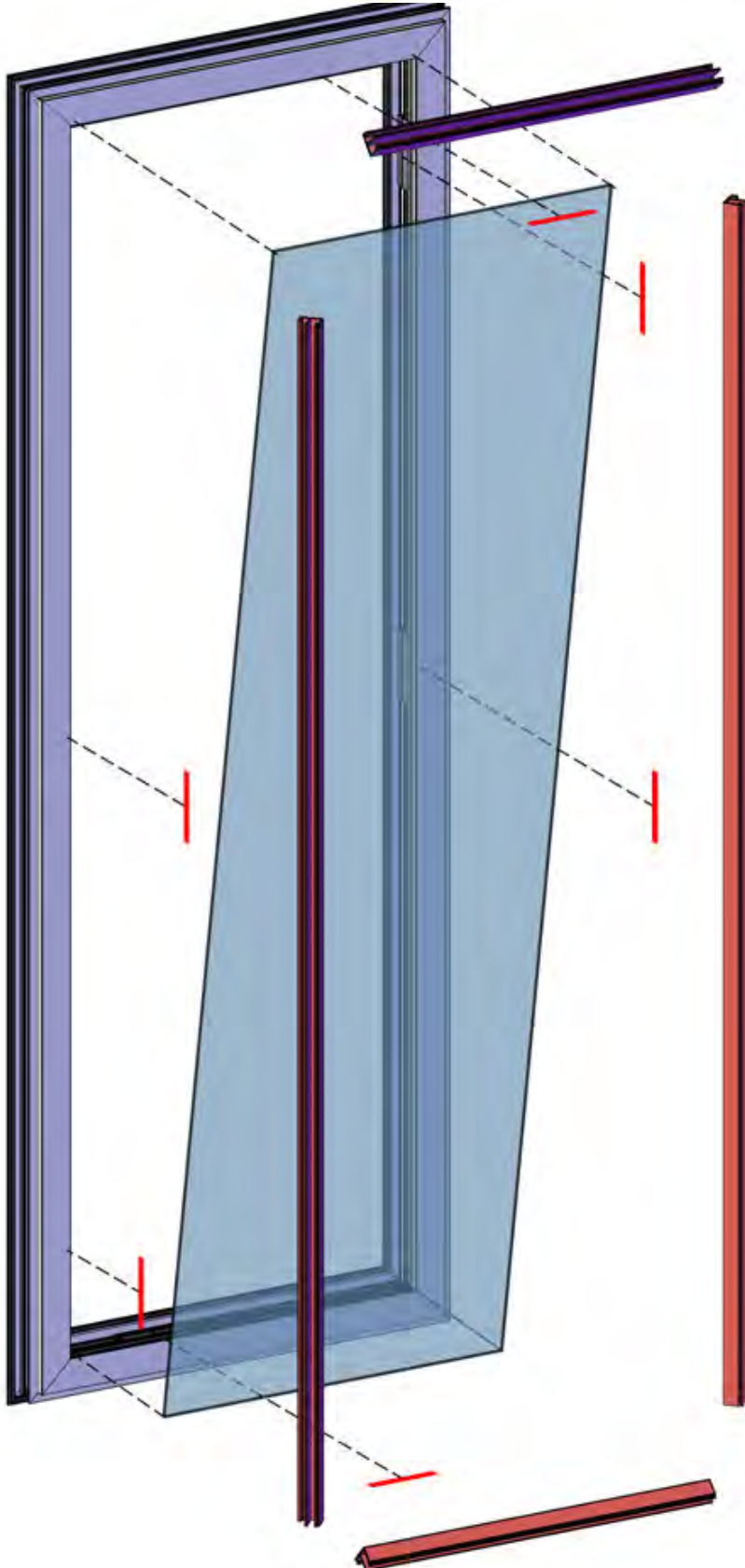
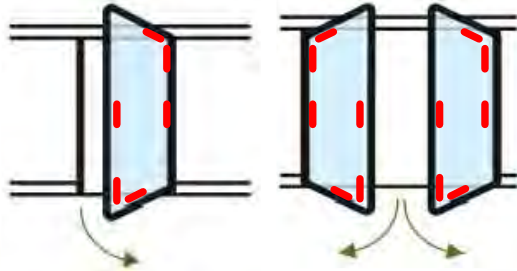

NOTE: the horizontal glazing strips shown in red above may be slightly long. Please measure and trim to fit your door using a hacksaw, hand file, angle grinder or similar tool.

HD 8

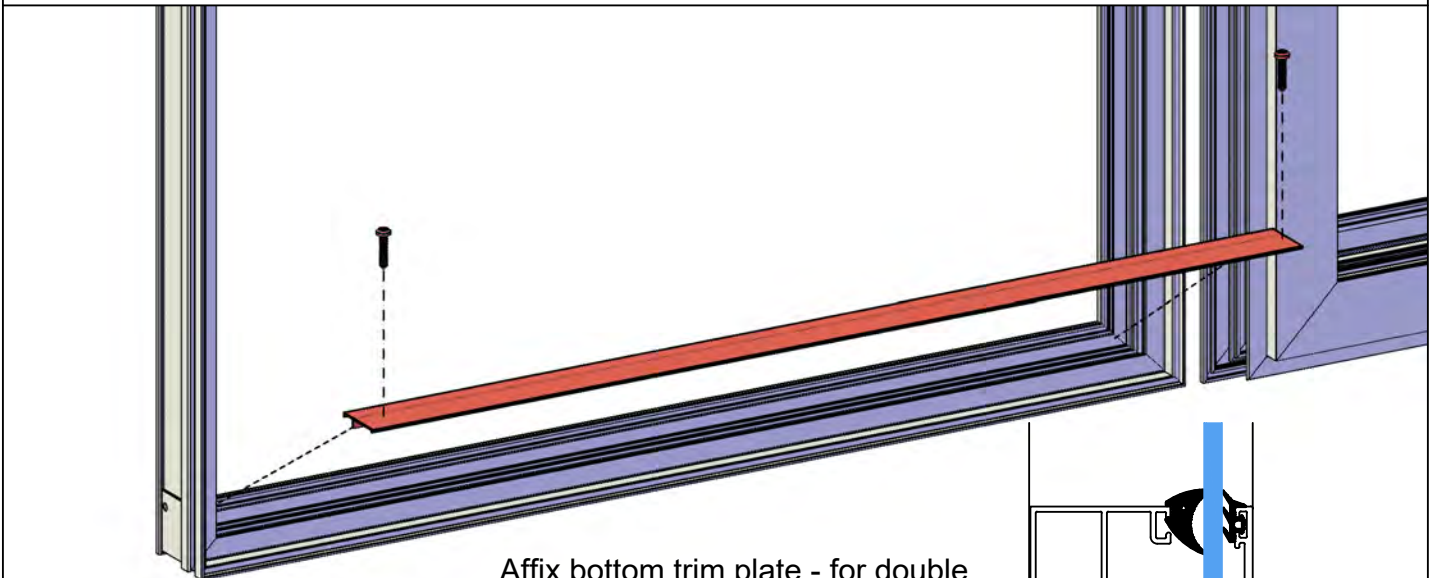
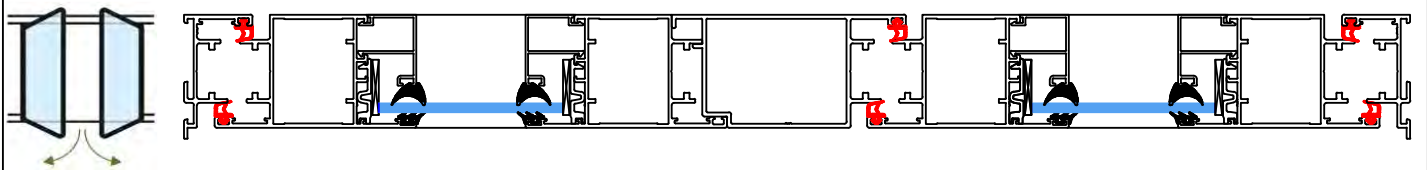
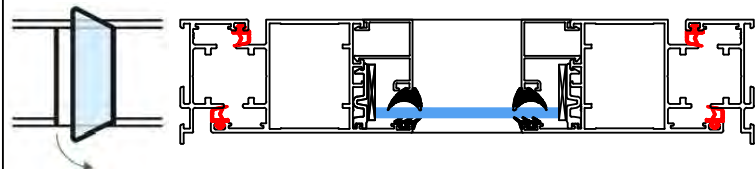
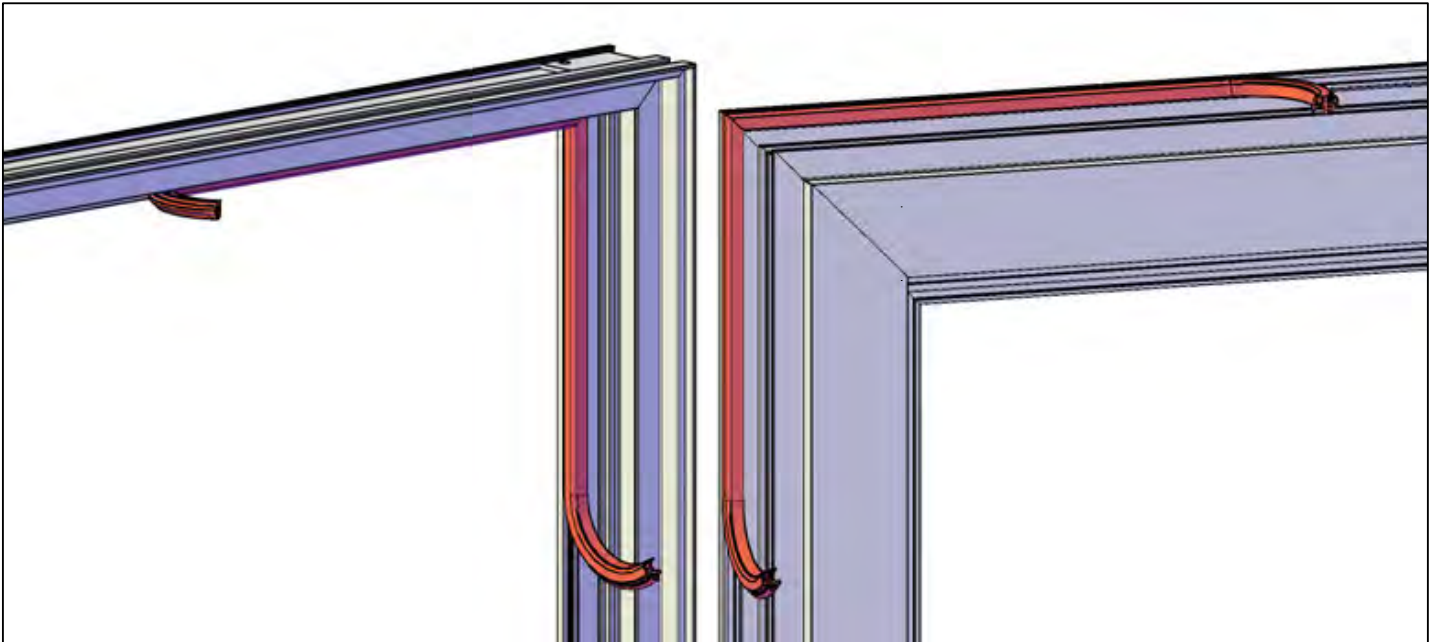

Affix bottom trim plate - for double doors see next page.

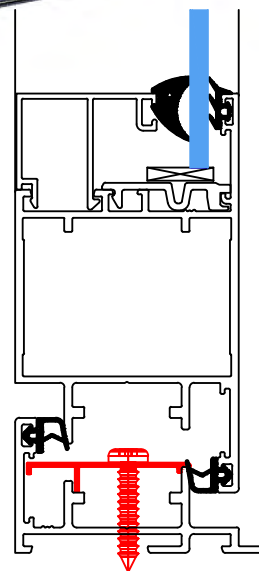

HD 9

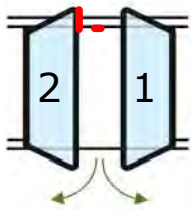

This page only applies to double hinged doors.

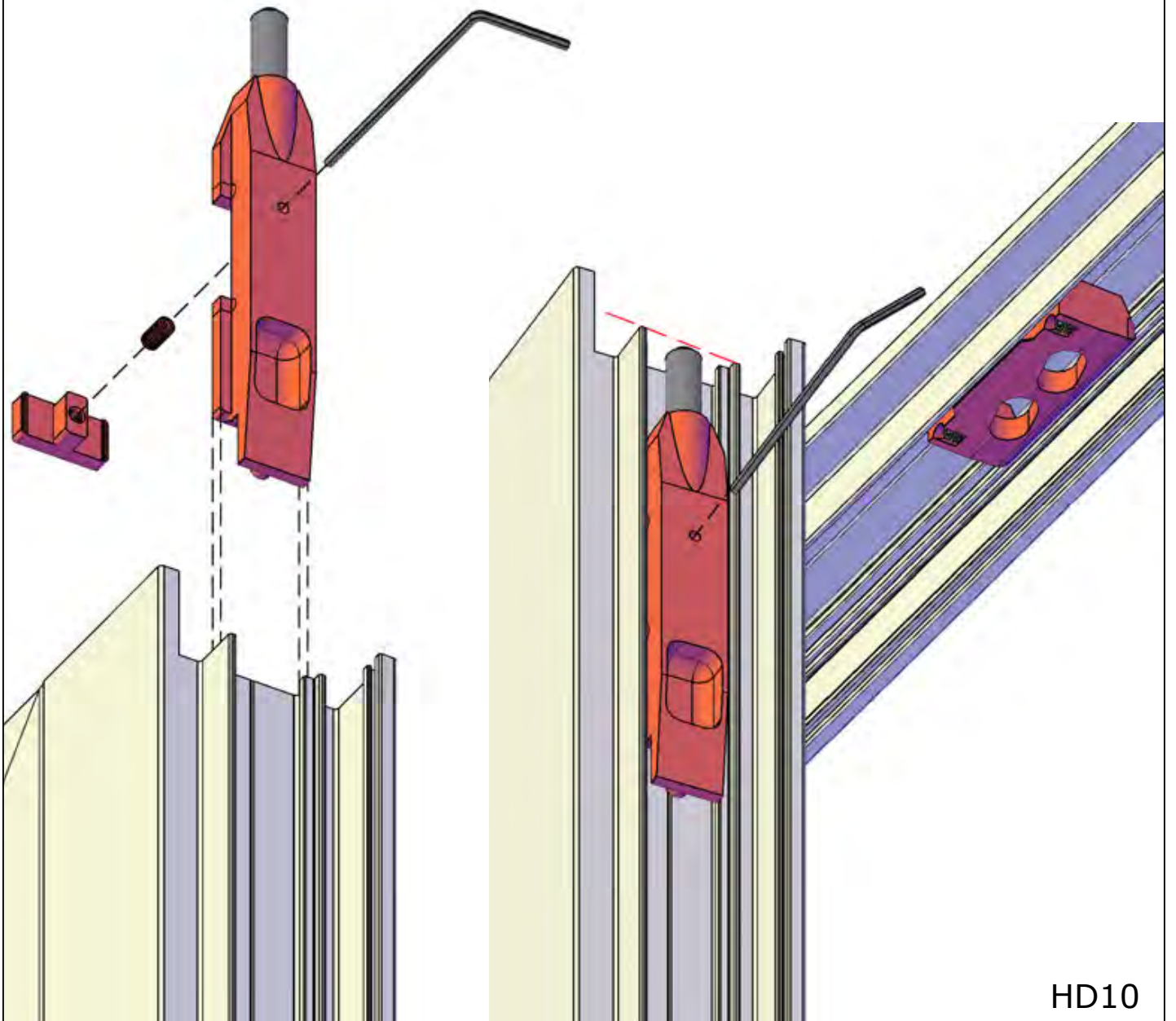
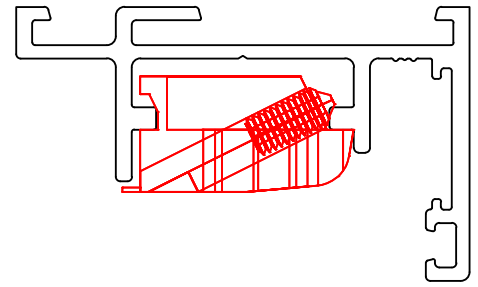
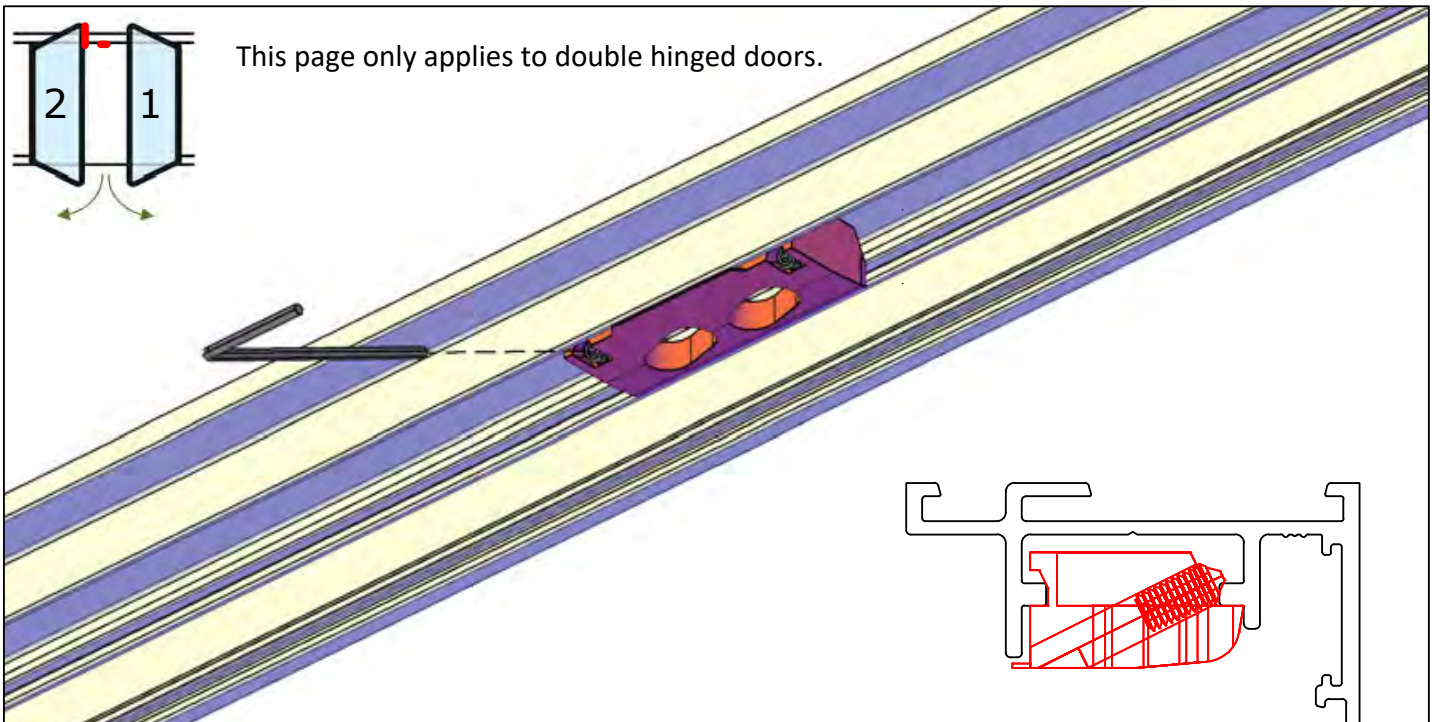

HD10

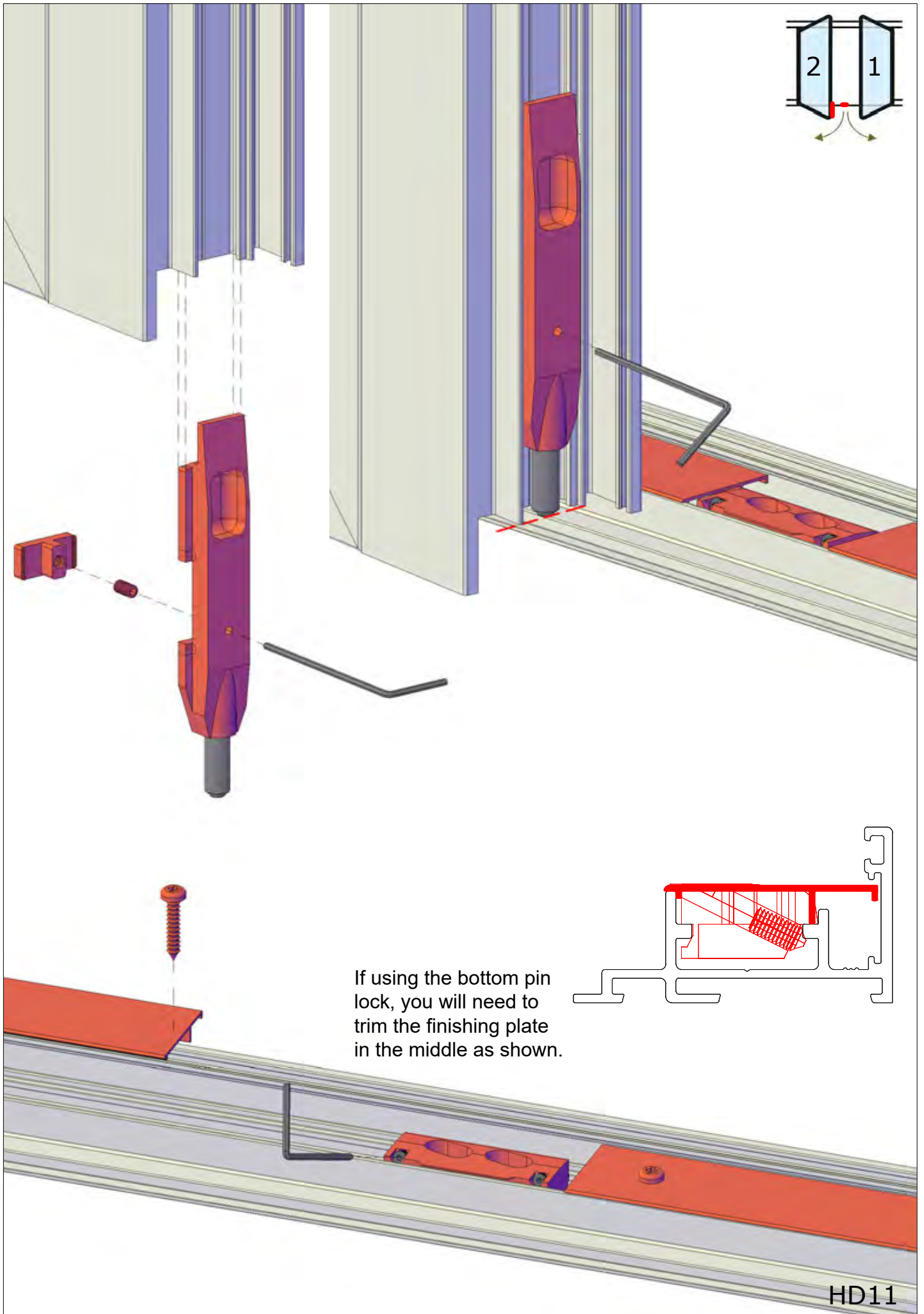

If using the bottom pin lock, you will need to trim the finishing plate in the middle as shown.



HINGE
ADJUSTMENT
(Left to Right)

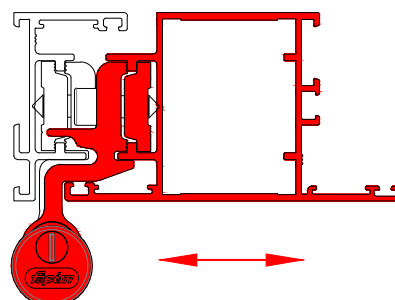
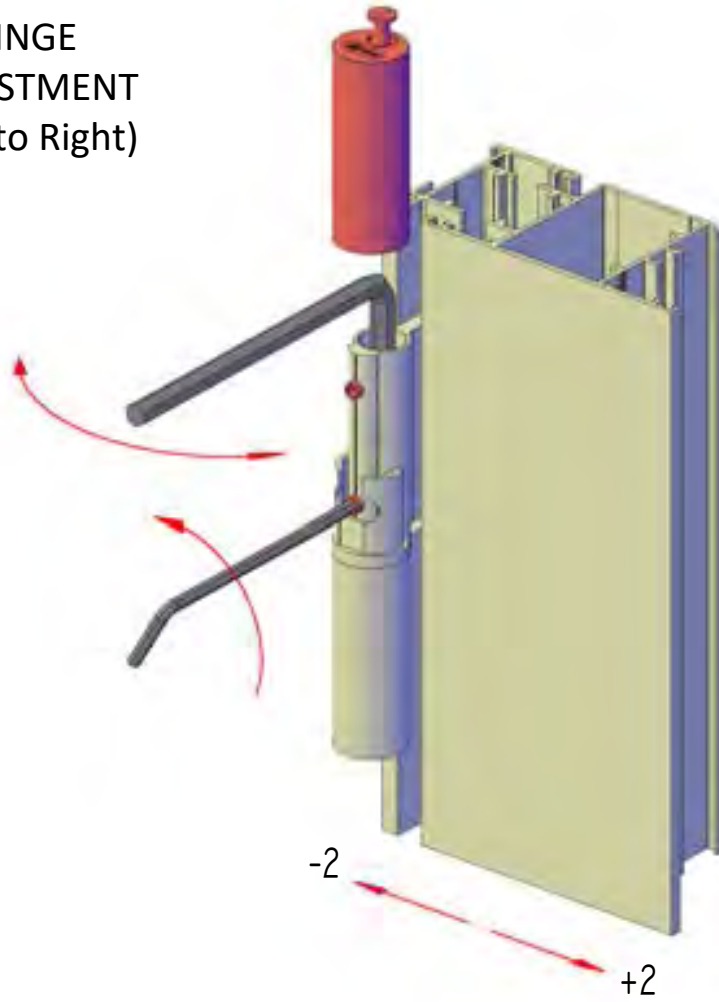

HD12



HINGE ADJUSTMENT (Up)

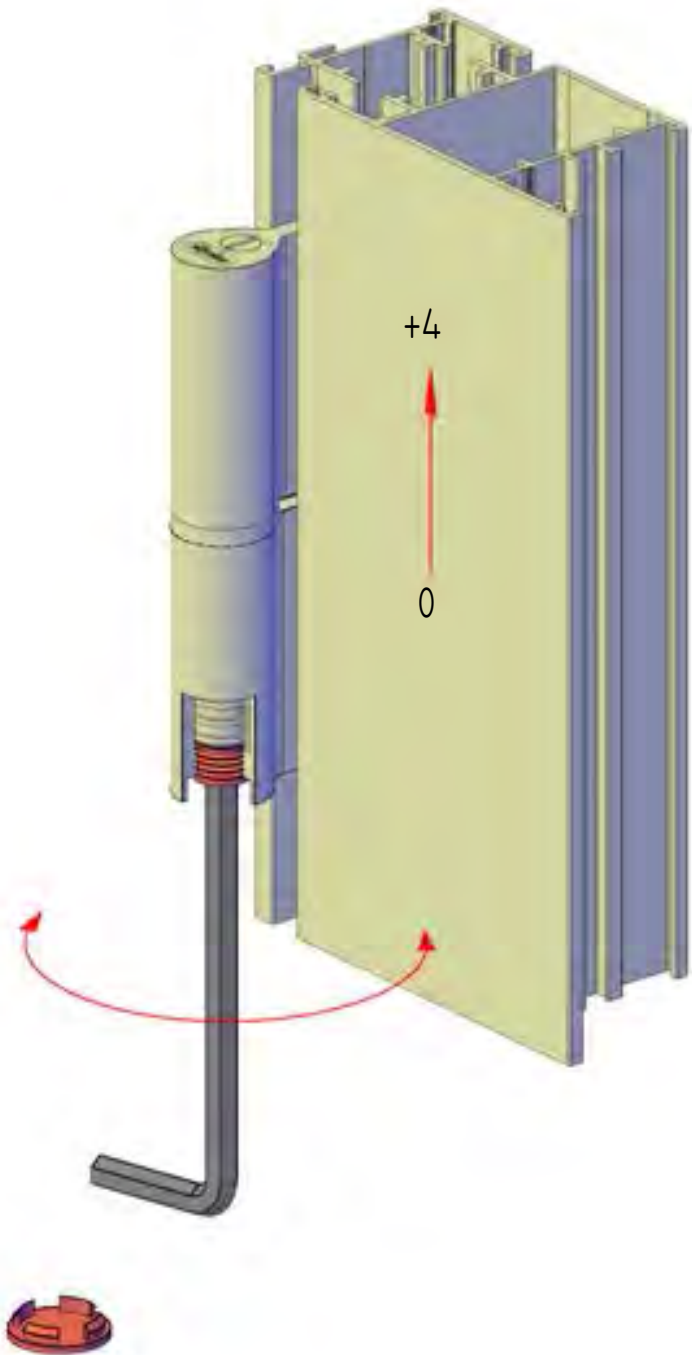

HINGE ADJUSTMENT (Front/Back)

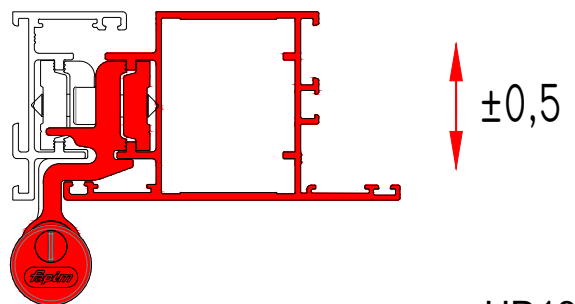
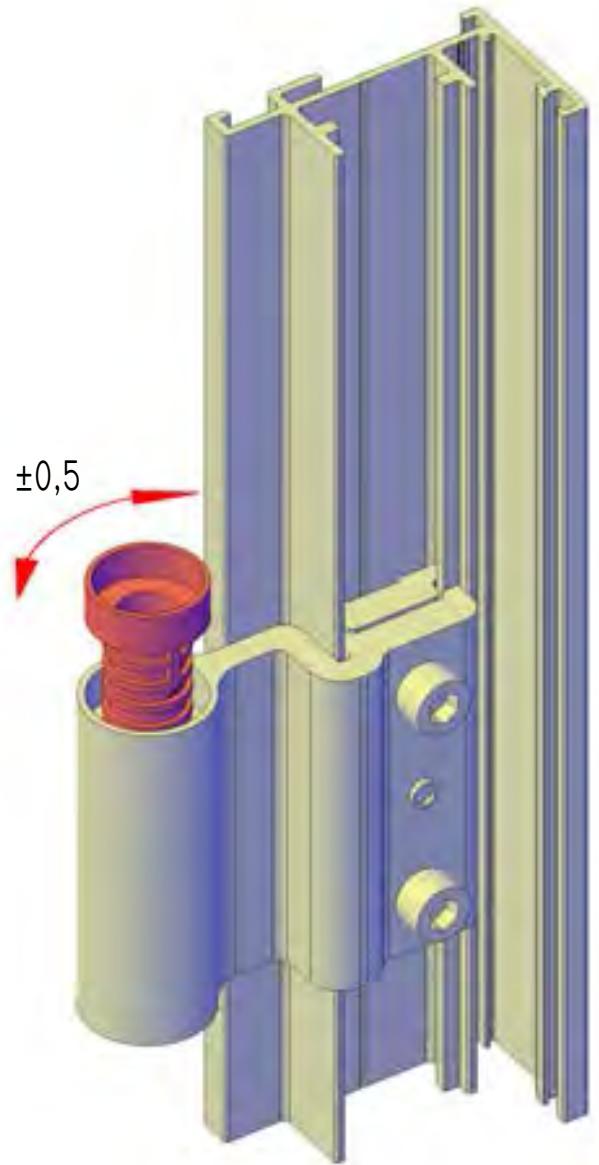

HD13



Optional Upgrade: Door Fly Screen

FD

Notes about Fly Screen Door: This slides along the interior of the greenhouse, and will not be compatible with greenhouses on a stem wall. May be used with sliding or hinged doors.

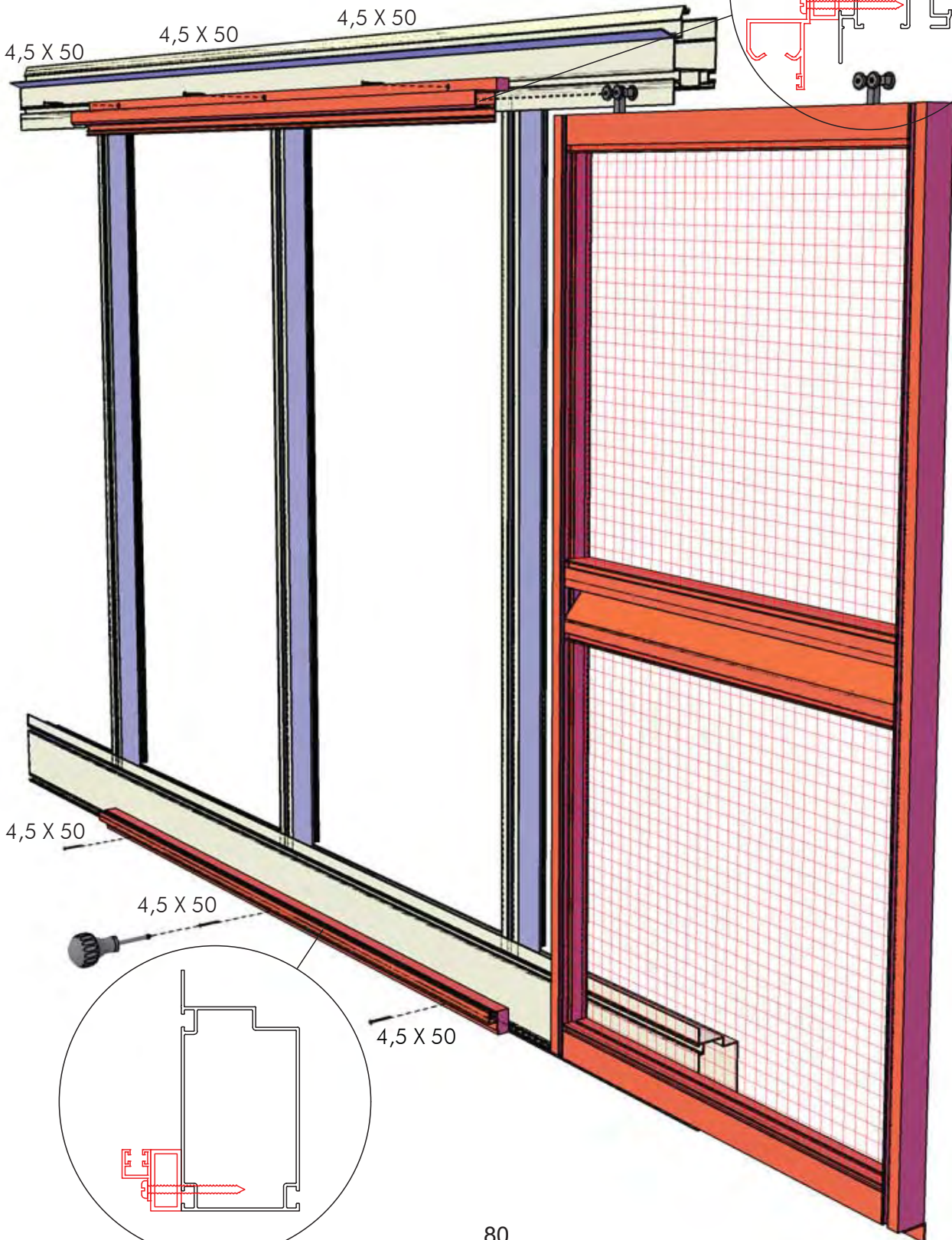
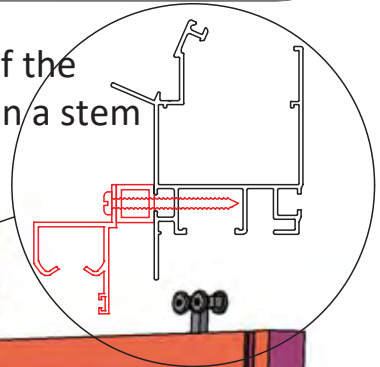

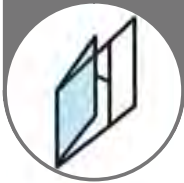

Roof Window /Vent -

all hardware will be included in roof vent package - including crossbar to frame opening

RW

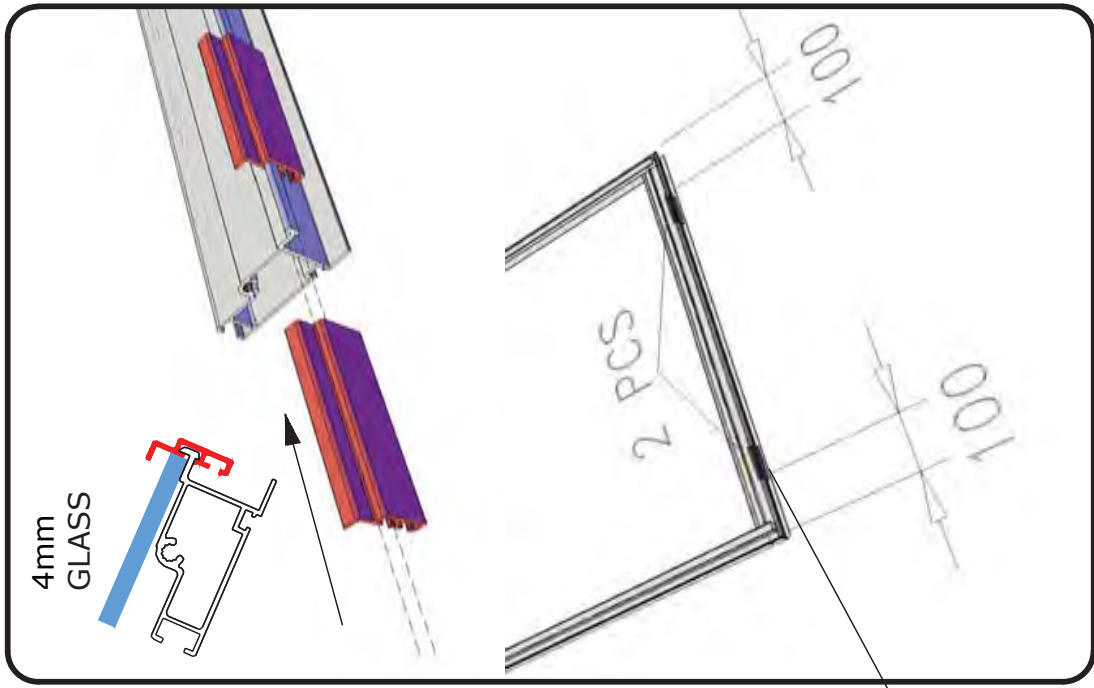
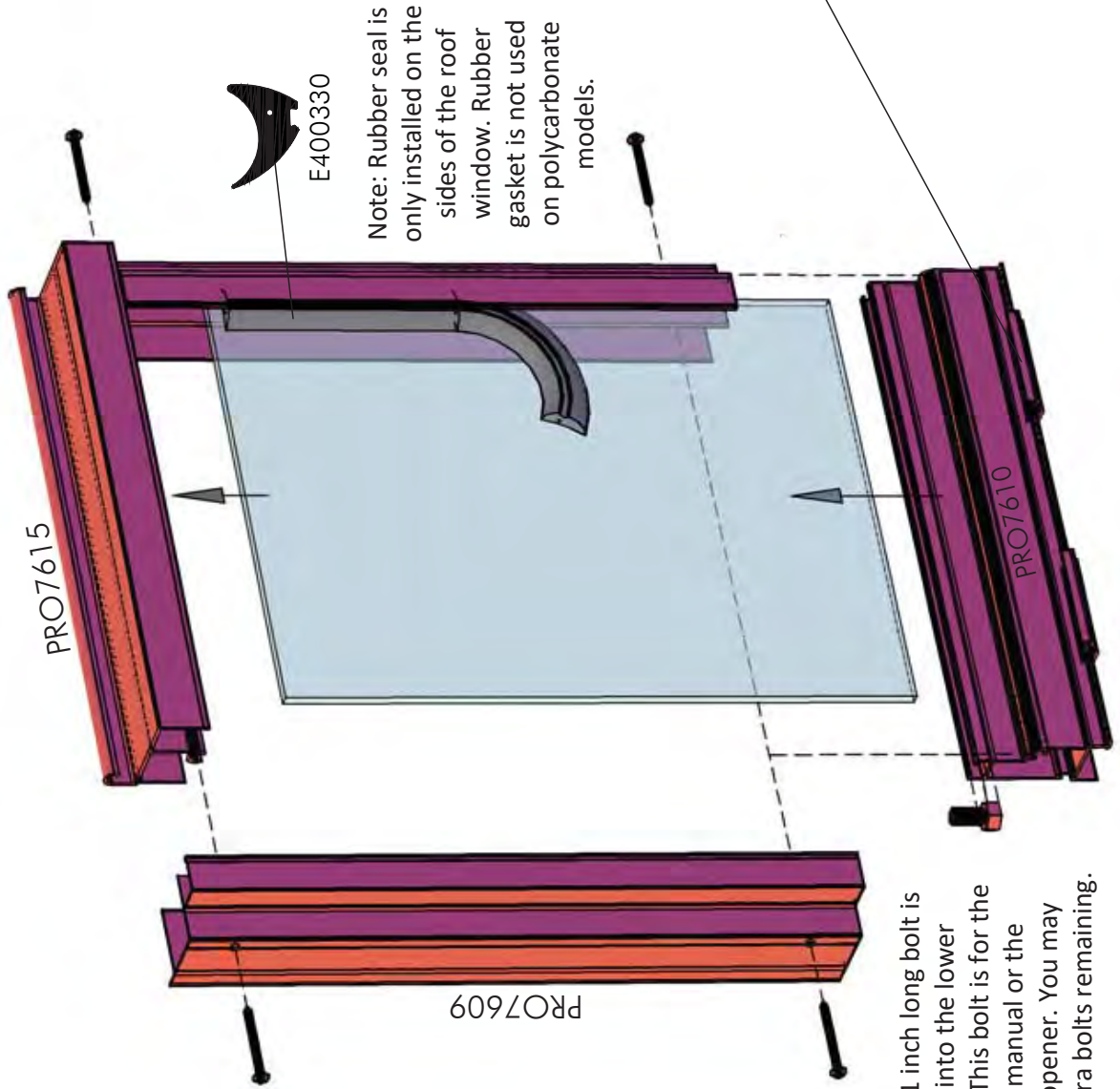

Roof Window Installation

Note: Inserting a bolt/nut on both sides of the roof window will prevent it from moving side to side once it is in place.

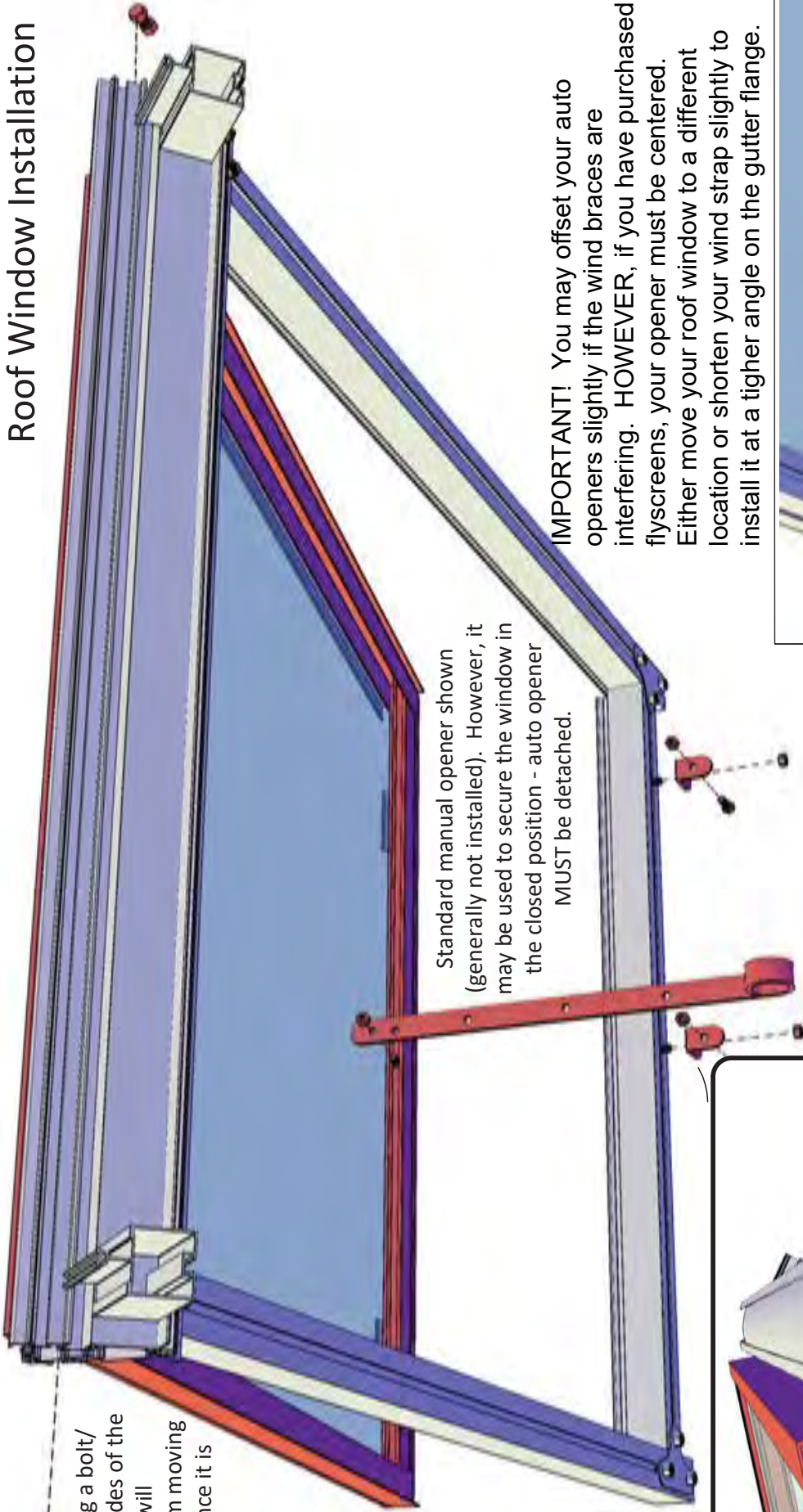

Standard manual opener shown (generally not installed). However, it may be used to secure the window in the closed position - auto opener MUST be detached.

IMPORTANT! You may offset your auto openers slightly if the wind braces are interfering. **HOWEVER**, if you have purchased flyscreens, your opener must be centered. Either move your roof window to a different location or shorten your wind strap slightly to install it at a tighter angle on the gutter flange.

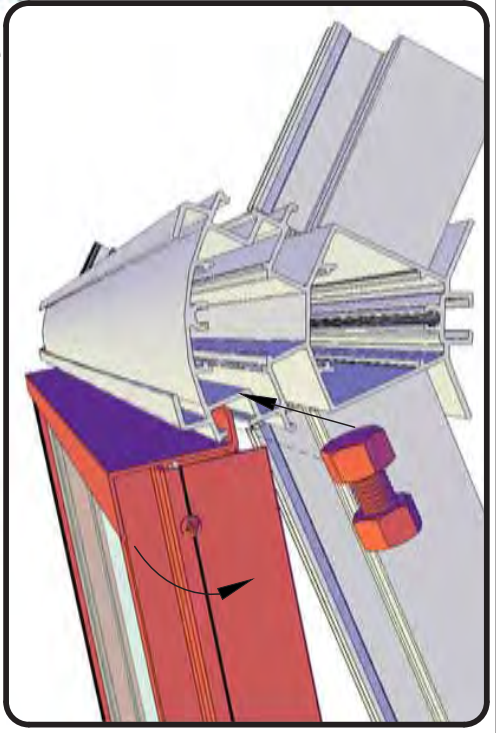

TO INSTALL: Slide window into the ridge beam from either end of the greenhouse. The "hook" on the top of the roof window profile will slide into the channel of the ridge beam (shown to the left).

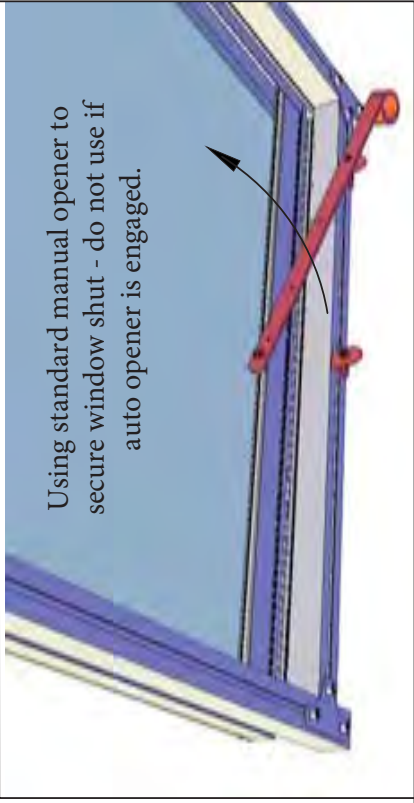

Using standard manual opener to secure window shut - do not use if auto opener is engaged.

OPTION: Auto Opener (Ventomax)

IMPORTANT! Read installation instructions included in your Ventomax auto opener box to ensure proper installation. There is also information to fully understand the functioning and maintenance of these unique openers.

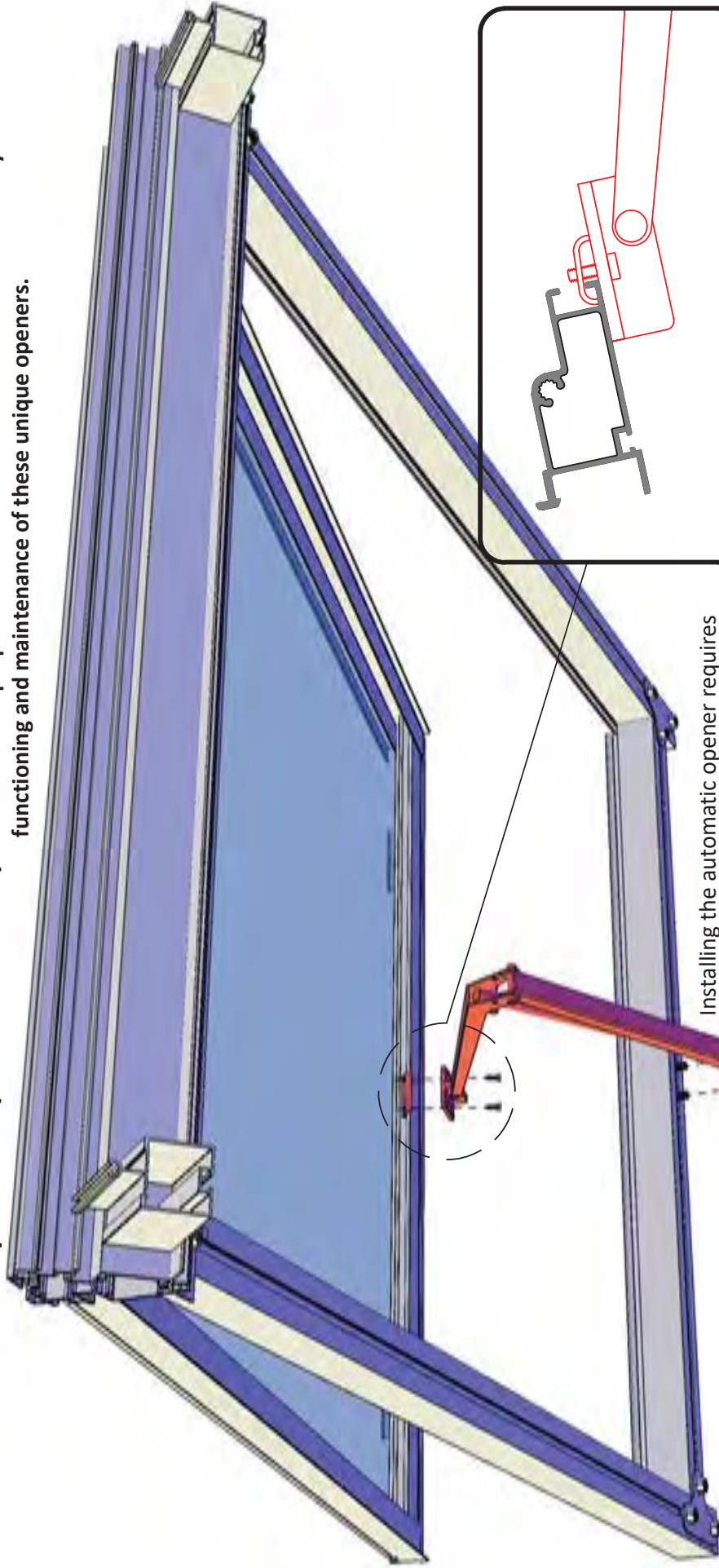

The Ventomax openers work with an oil filled piston (black cylinder). The oil begins to expand around 72 degrees and will push out and open your window when the temperature in the greenhouse is above 75 degrees (outdoor temp will likely be cooler).

If you are struggling to install your piston and it is above 70 degrees, place the piston in cold water/ fridge for 10 minutes so the rod can retract.

Oil piston rod 2-3 times/year with a light oil such as WD40 or even olive oil.

Installing the automatic opener requires 2 bolts to be inserted into the roof crossbar for the lower mount. The upper mount will clamp onto the window profile. (Shown to the right)

OPTION: Spindle Manual Opener

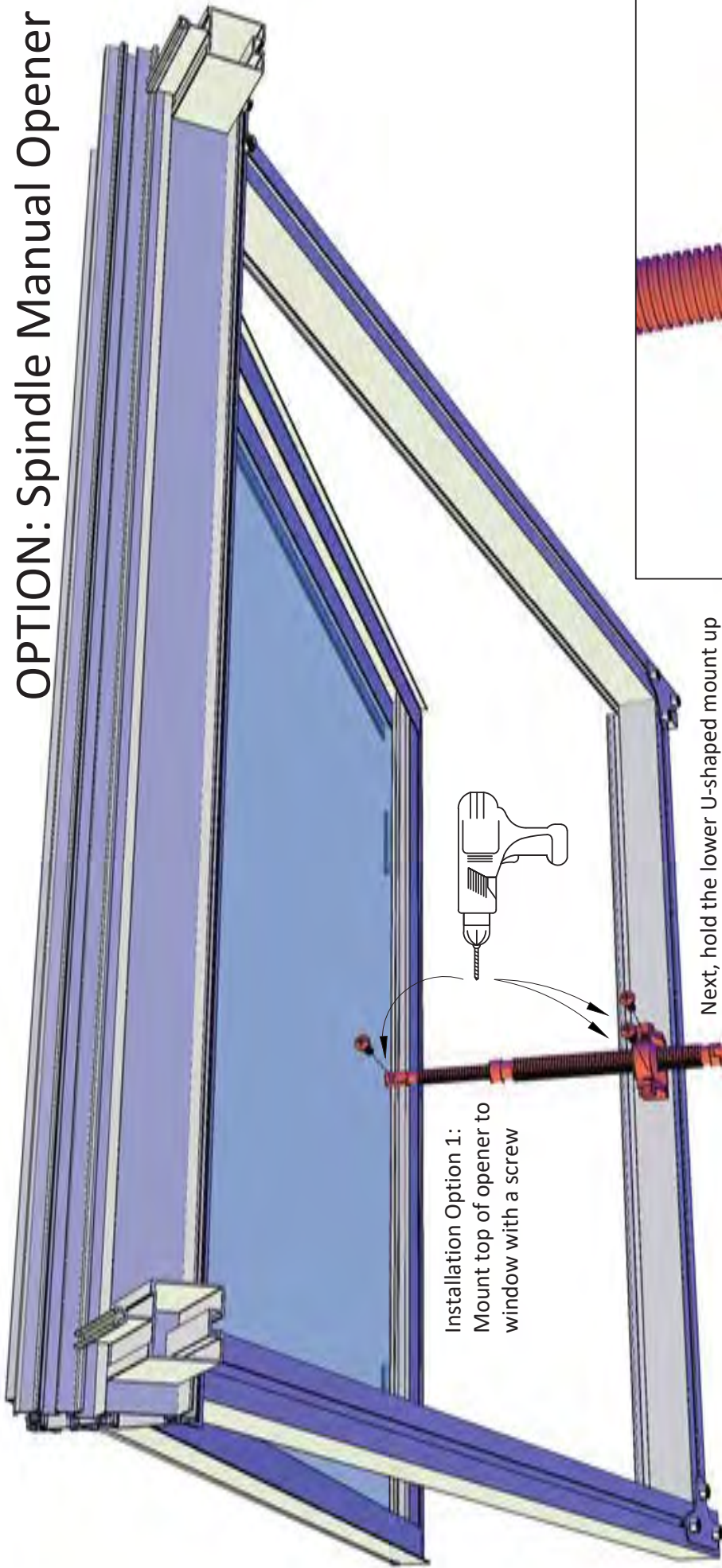

Installation Option 1:
Mount top of opener to
window with a screw

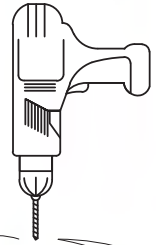

Installation Option 2: Insert a 1 inch long bolt into lower roof window channel. Slide to the center and lock it in place with a nut as shown below.

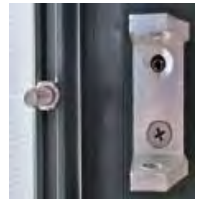
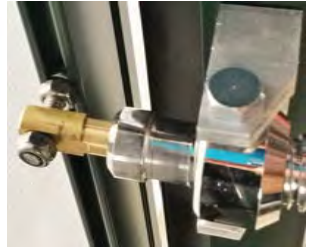

Next, hold the lower U-shaped mount up to the crossbar and mark the center of one hole. Using a 1/8" drill bit, drill the first hole, then screw the bracket on, check for level - then mark and drill the second hole. Slide the brass part of the opener over the bolt in the window channel. Use the supplied nylock nut to secure the opener on the top mounting bolt. Finally thread the large side bolts into the U-shaped mount and the opener is installed.

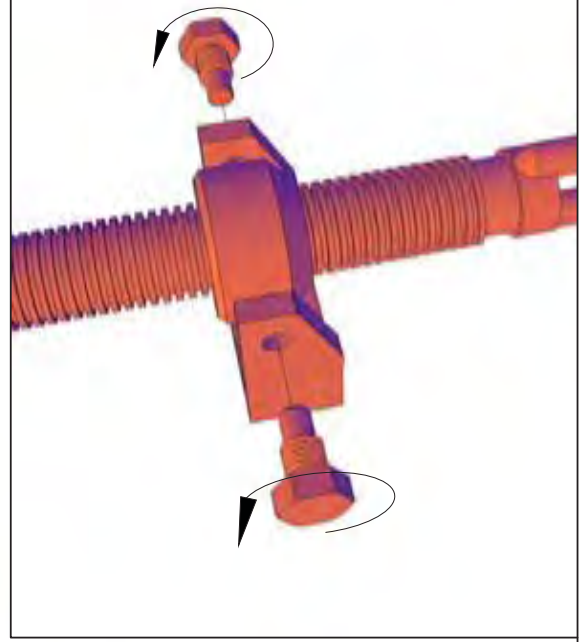



OPTIONAL UPGRADE: Fly screen for roof vent

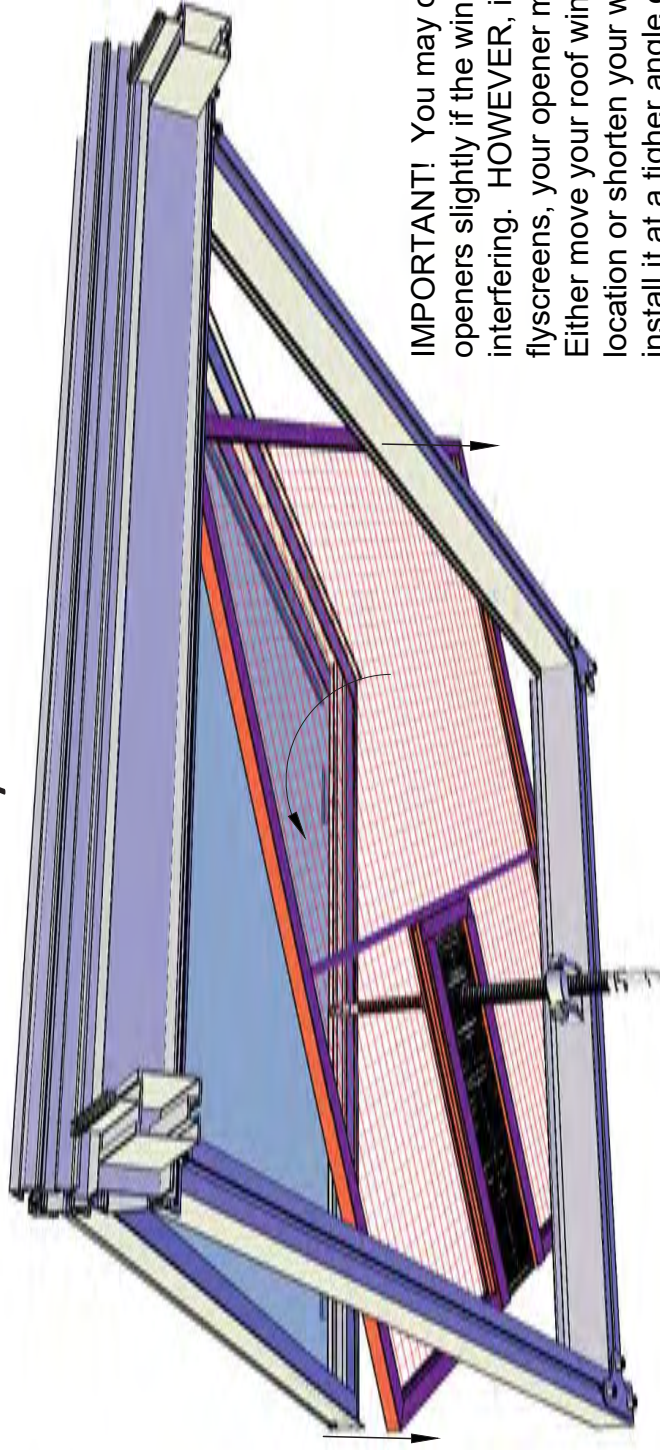

IMPORTANT! You may offset your auto openers slightly if the wind braces are interfering. **HOWEVER**, if you have purchased flyscreens, your opener must be centered. Either move your roof window to a different location or shorten your wind strap slightly to install it at a tighter angle on the gutter flange.

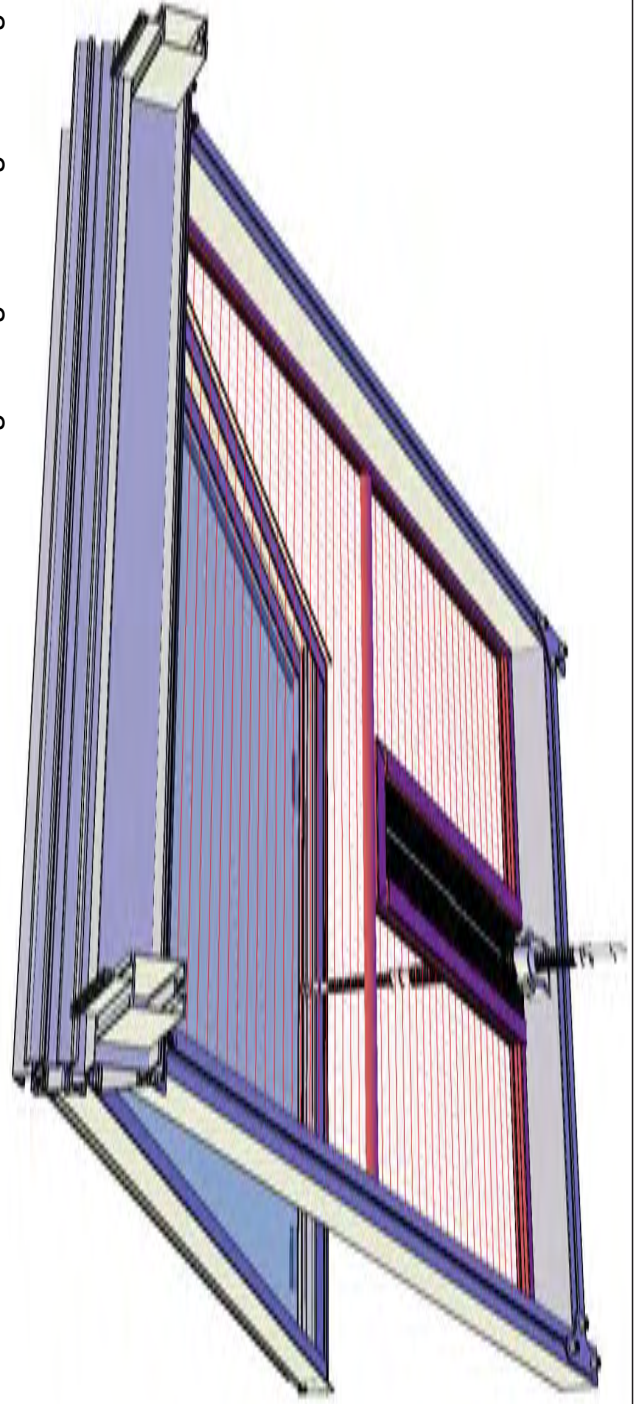



Louvre Window - All Standard Royal models include one louvred window

LV

Note: All louvered window are black (even with green models)

Numbers below refer to steps in the following pages



It is likely that your kit include an automatic opener (SESAM LIBERTY) for the louvre vent. Please refer to the Installation and Care manual packaged with the Sesam Liberty opener. You will need to remove the manual opener following the directions.

Piston maintenance: apply a light oil (WD40 or olive oil work) to the piston rod to keep it moving smoothly 2-3 times/year.

1

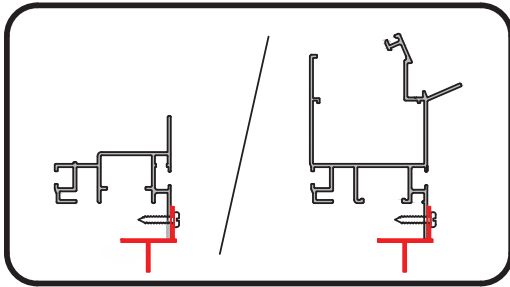

Louvre window may be installed on sidewall (under gutter profile (PRO20227)) or on gable end (under horizontal gable profile (PRO20229)). Both are shown to the left and below.

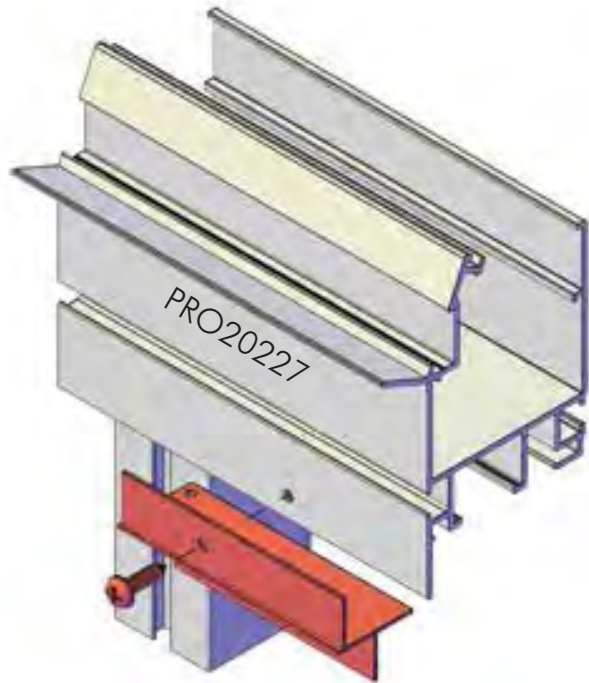
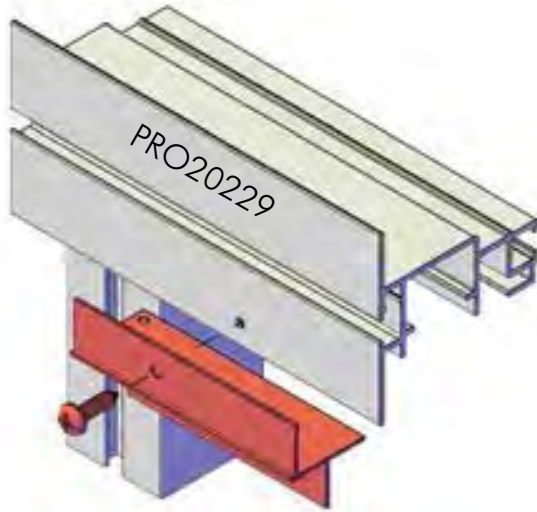

2

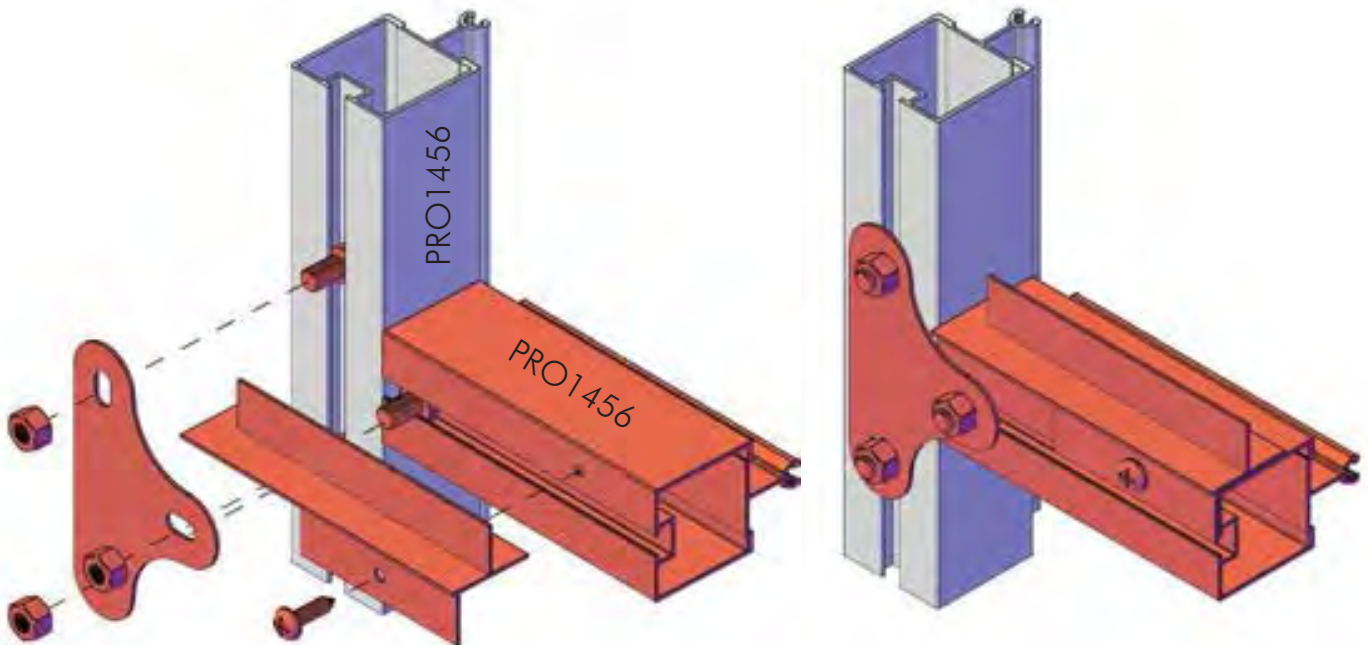

3

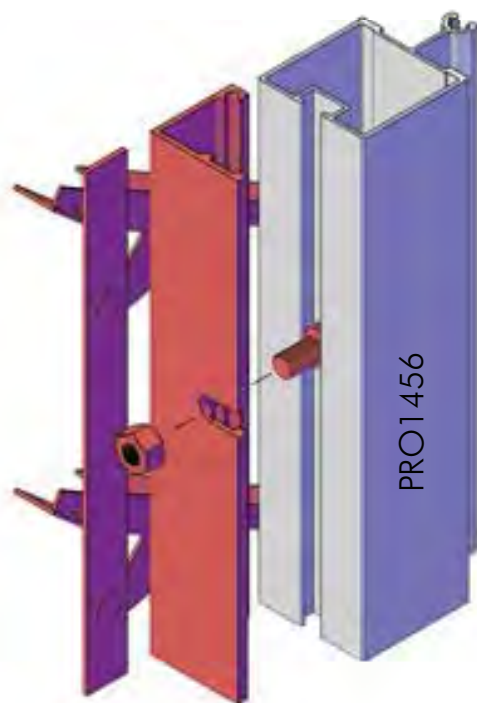

Insert a washer (not included) between black louvre frame and the greenhouse profile at all four bolt locations.

4X

4

Pinch louvre clamps together to hold glass. We recommend using a few dabs of silicone where the glass meets the clamps to hold the glass more securely. You may use the silicone that came with your red shims.

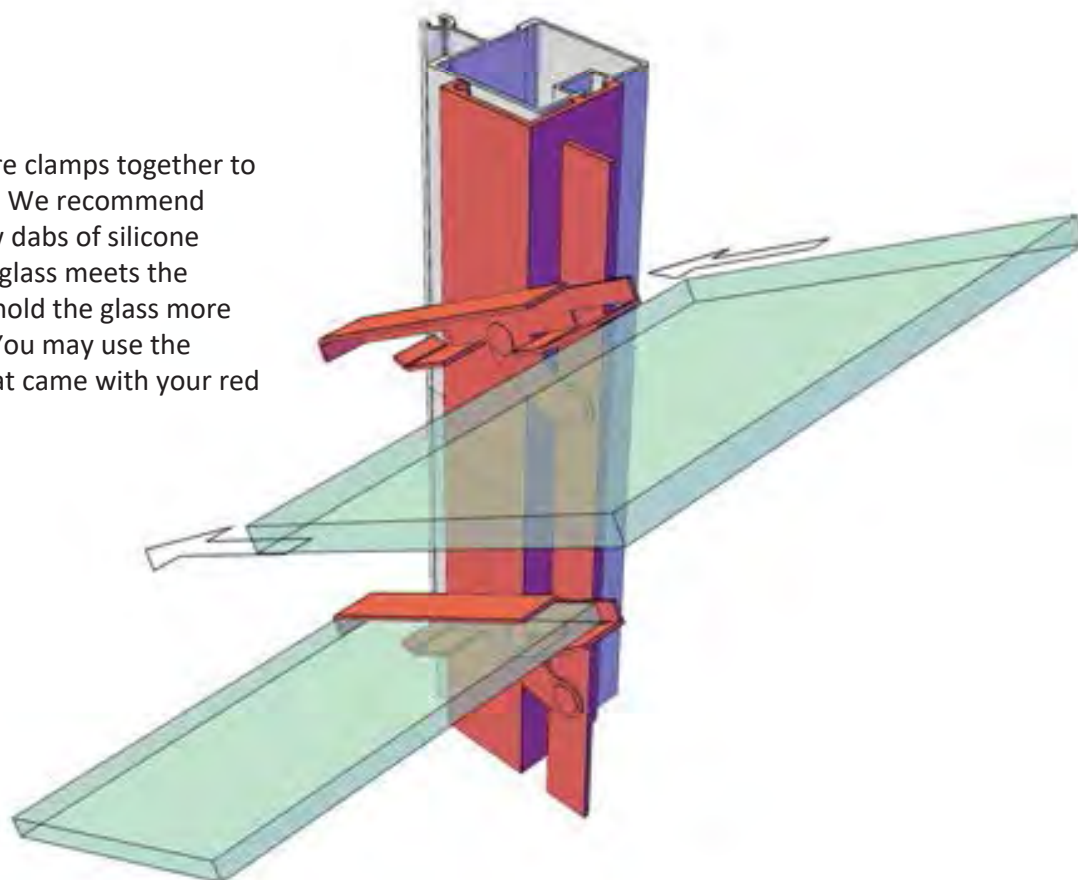

Louver Window Cover

During cold weather, the louvered window may get drafty. Your kit includes a lexan cover to seal the louvers during this time.

To install the Lexan panel:

- Unscrew the piston from your auto opener
- Go outside the greenhouse and pull back the heavy duty rubber gaskets that hold in the panes of glass to the left, right, and bottom of the louvered window (see picture to the right)
- Place the lexan panel over the louvers as though it were a pane of glass and replace all the heavy duty gaskets (see photos below)





OPTIONAL UPGRADE: Louvered
Window Fly Screen

FLV



Installed on exterior of the greenhouse

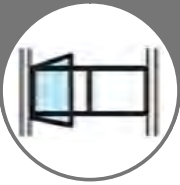

OPTIONAL UPGRADE: Push out window -
only Retro Victorians include this option

SW

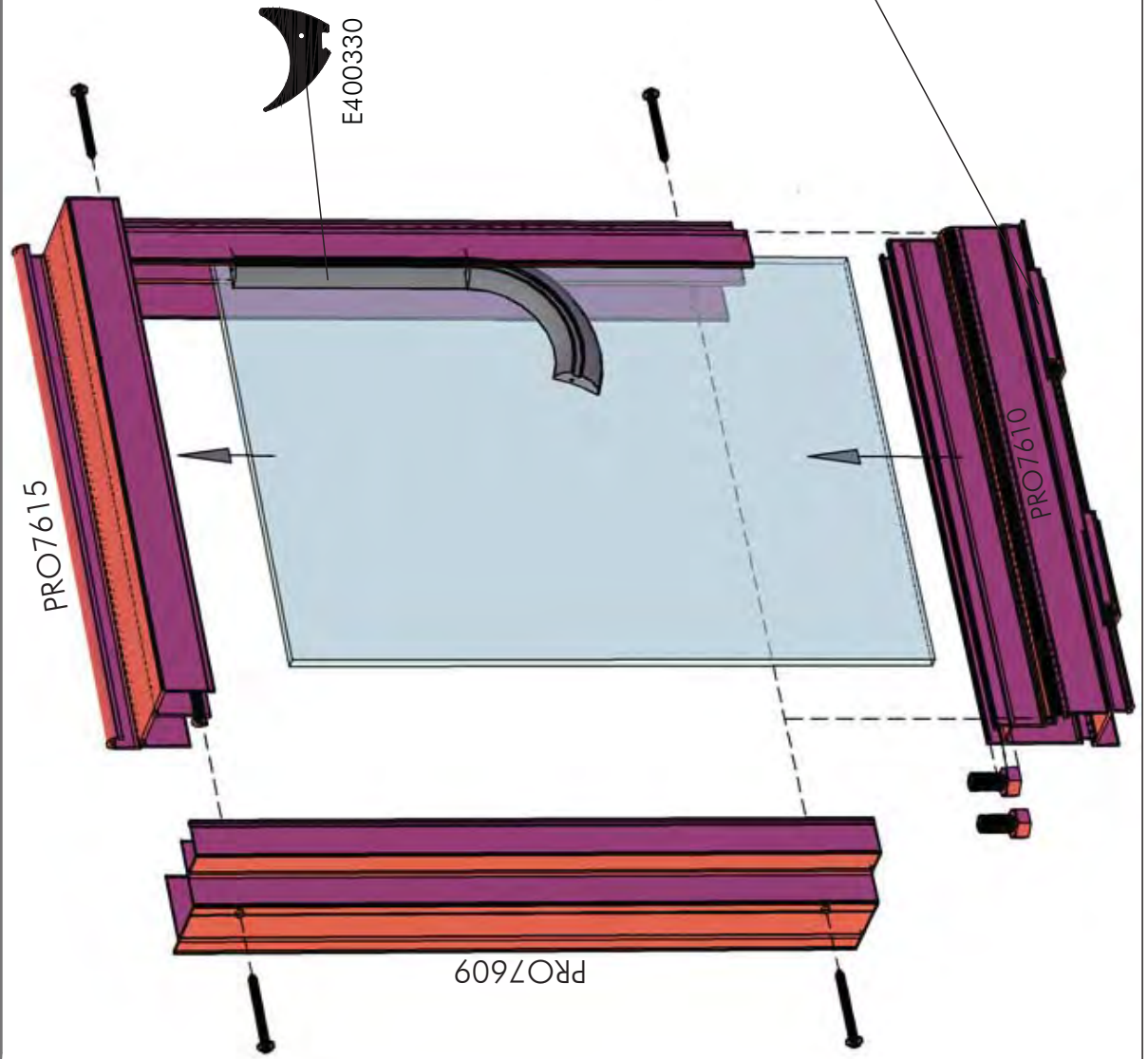
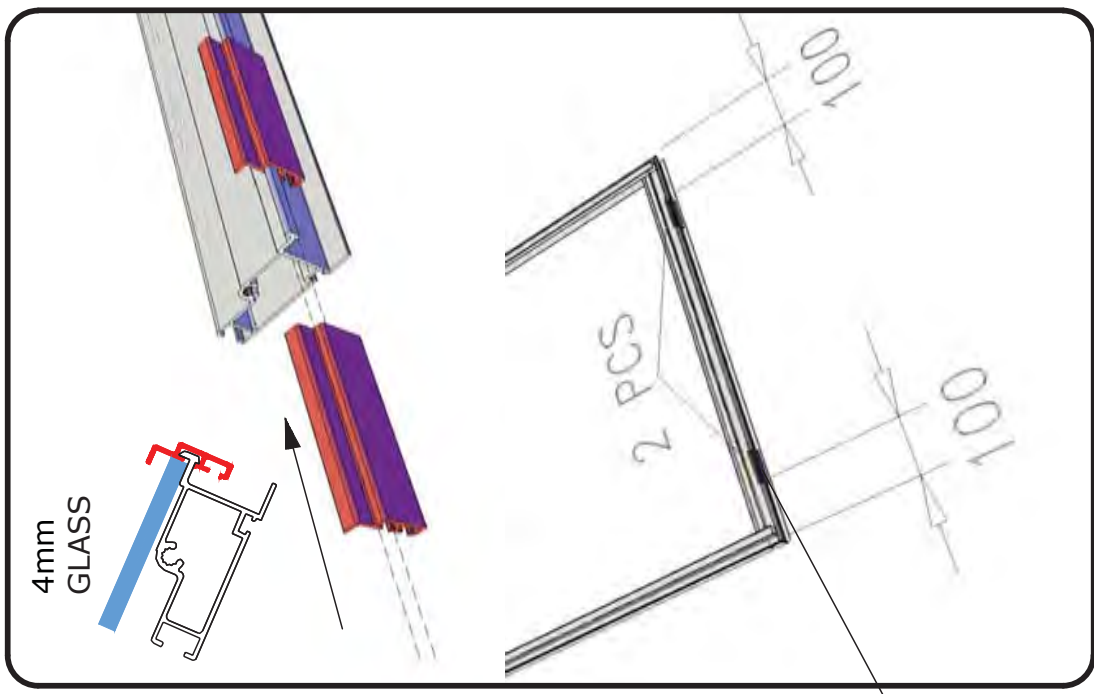

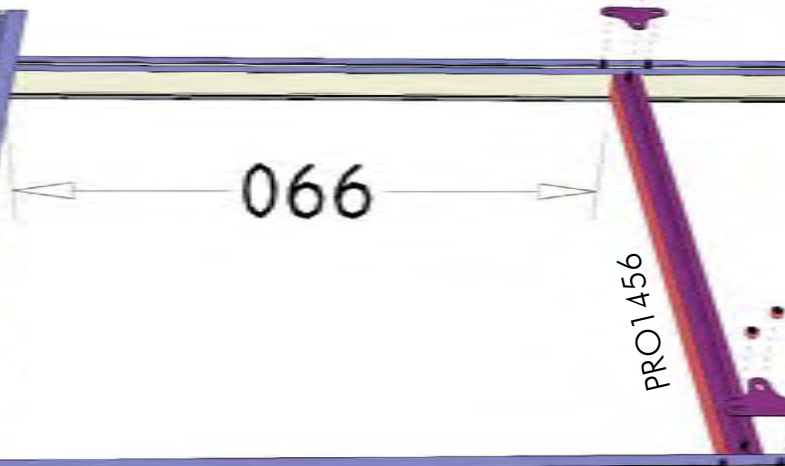
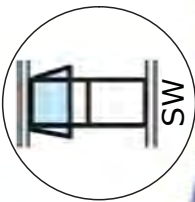

You may have a shorter push out window. If so, install small piece of glass and crossbar (PRO1456) underneath your window.

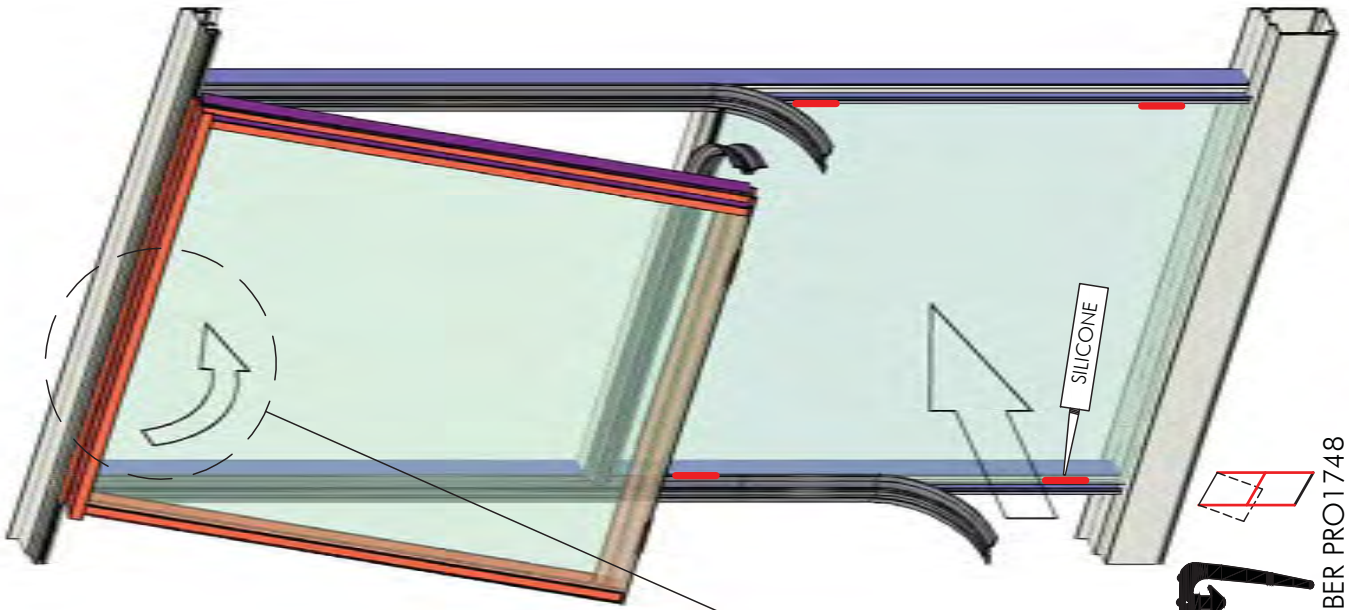
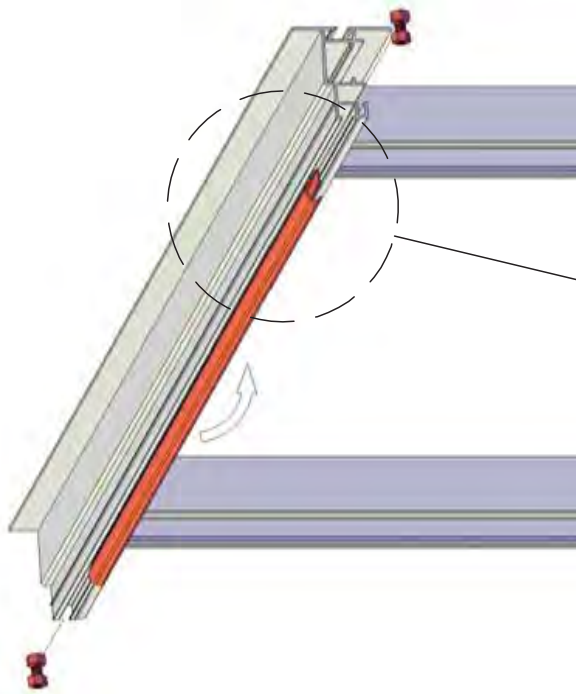
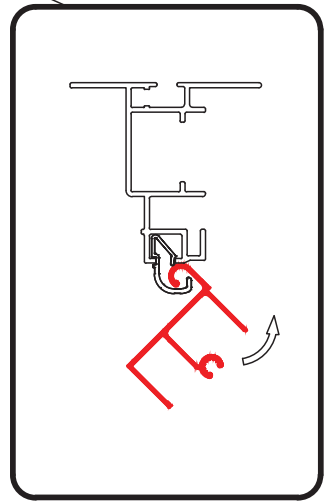
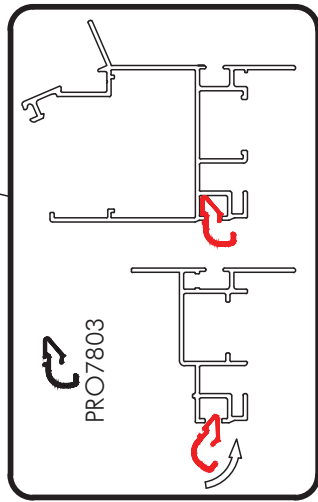

RUBBER PRO1748

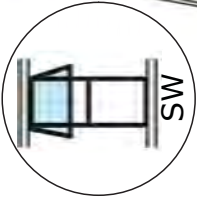
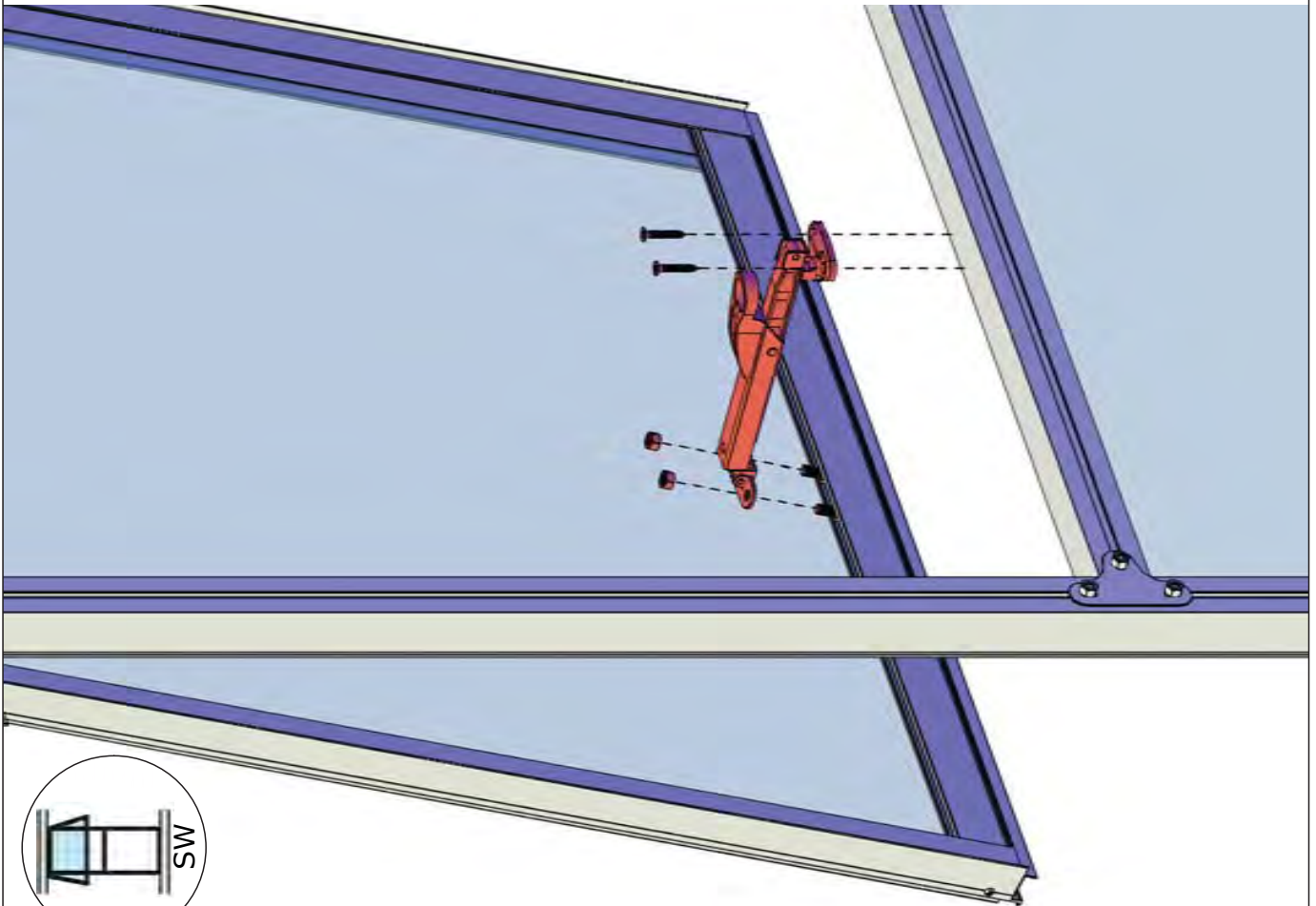
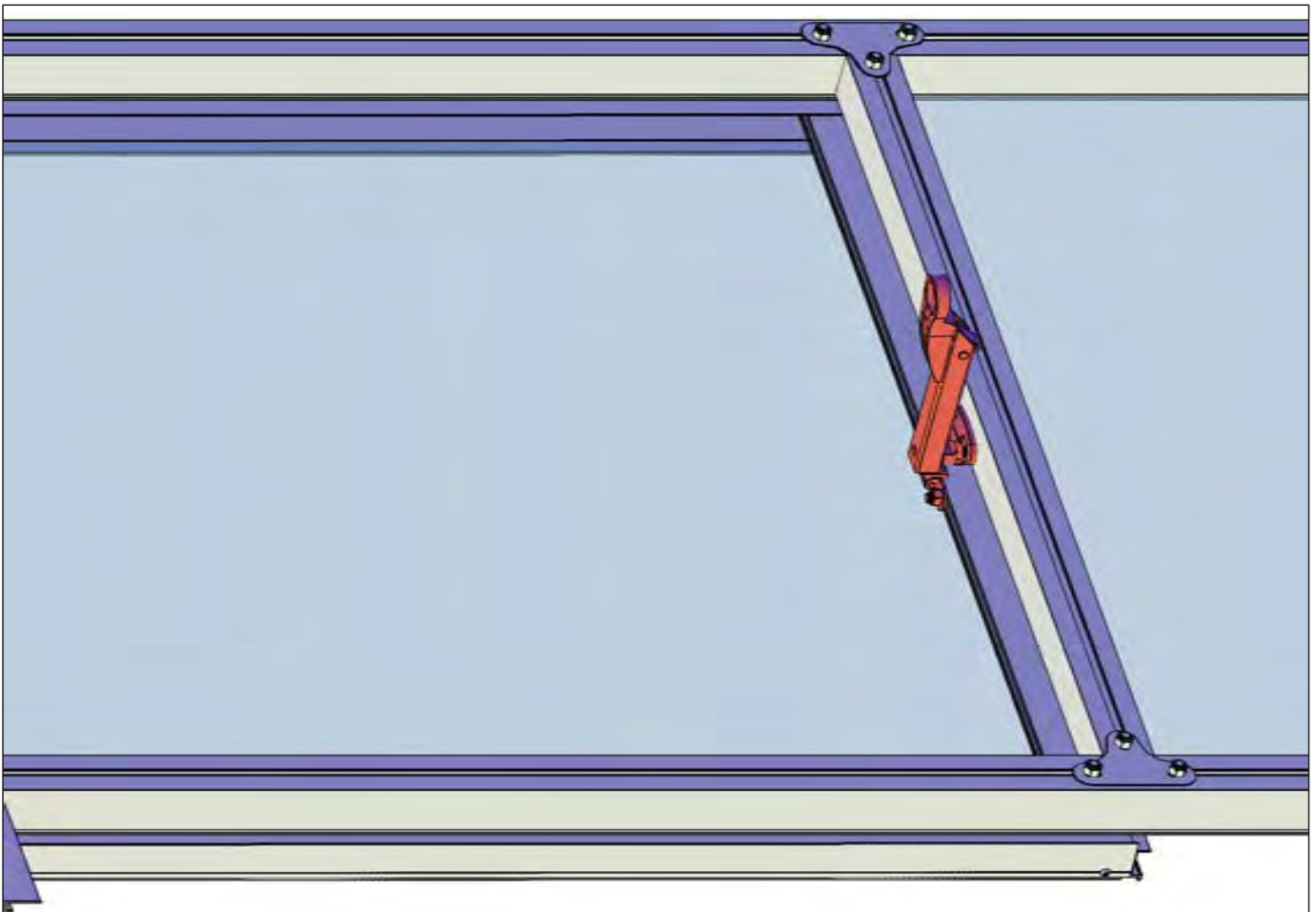

OPTION: Narrow Top Shelf - please check your order to see if this is included

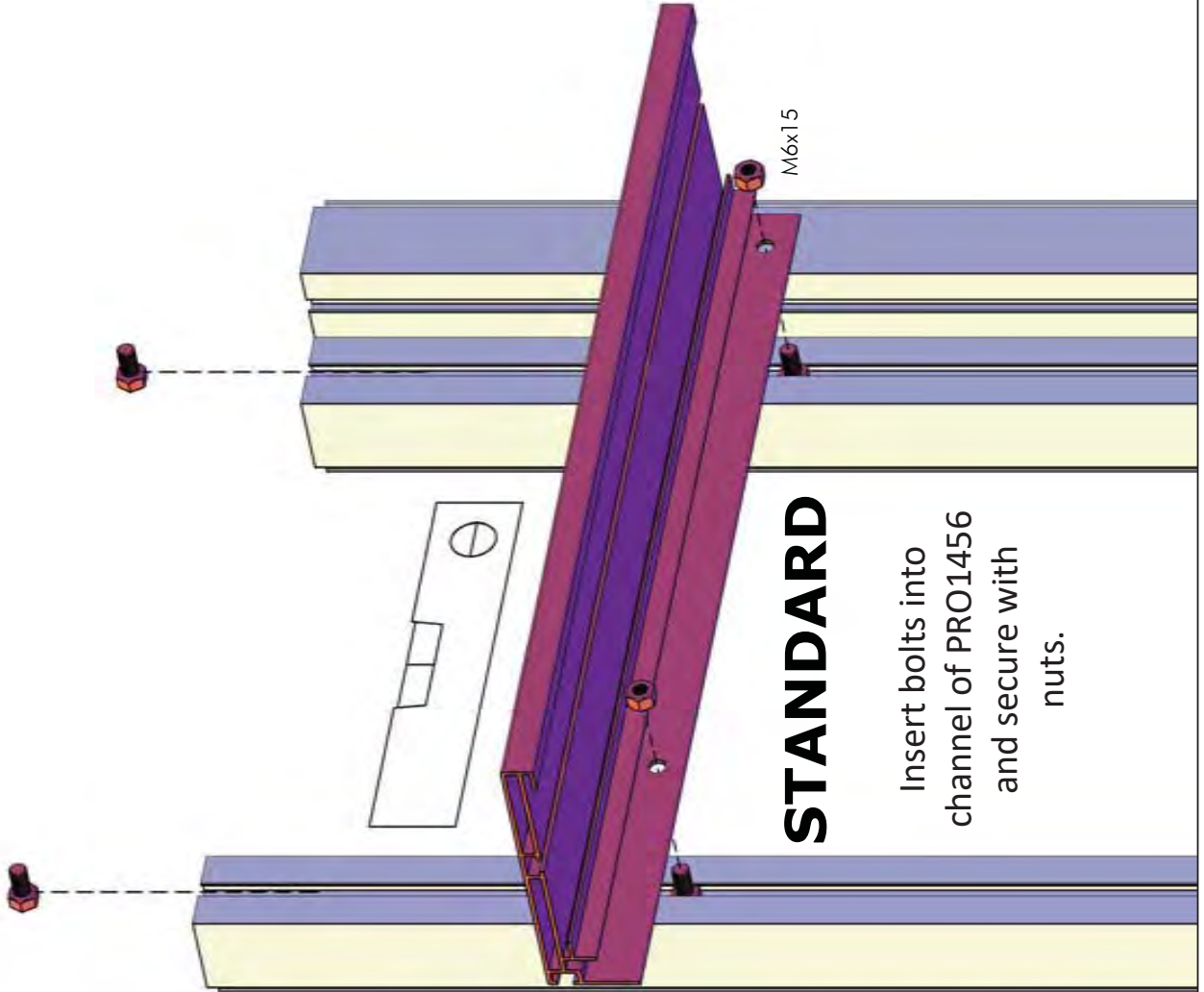
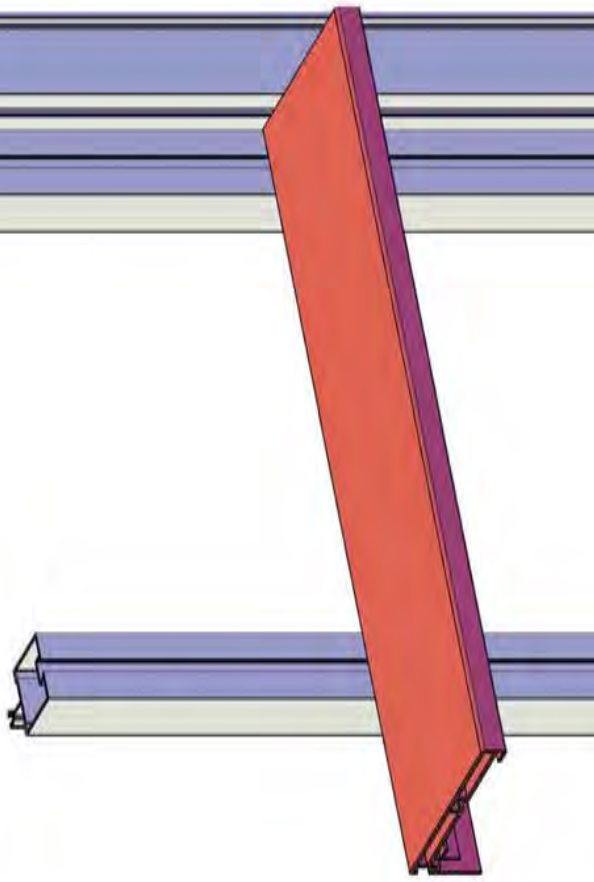

STANDARD

Insert bolts into channel of PRO1456 and secure with nuts.

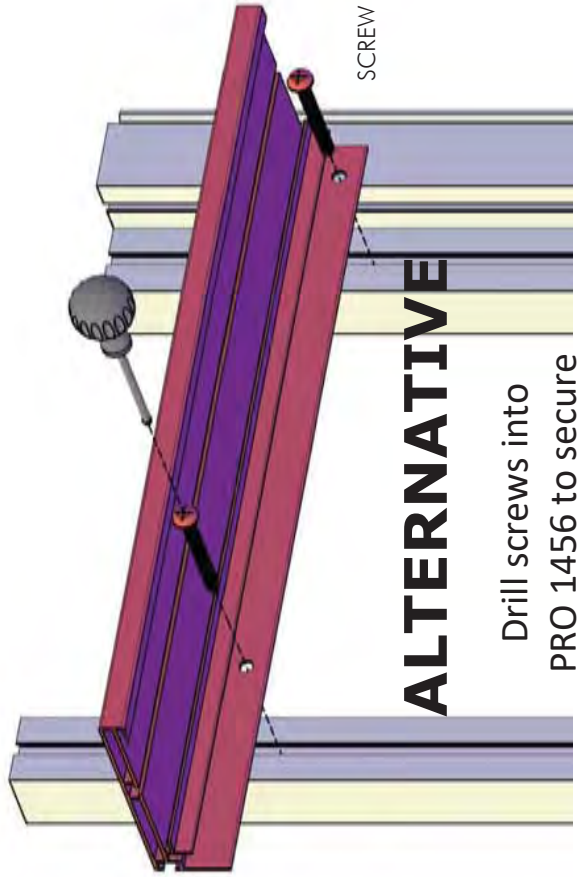

ALTERNATIVE

Drill screws into PRO 1456 to secure

SH

OPTION: SEEDBED/SEEDTRAY (ST) Please check your order to see if this was included

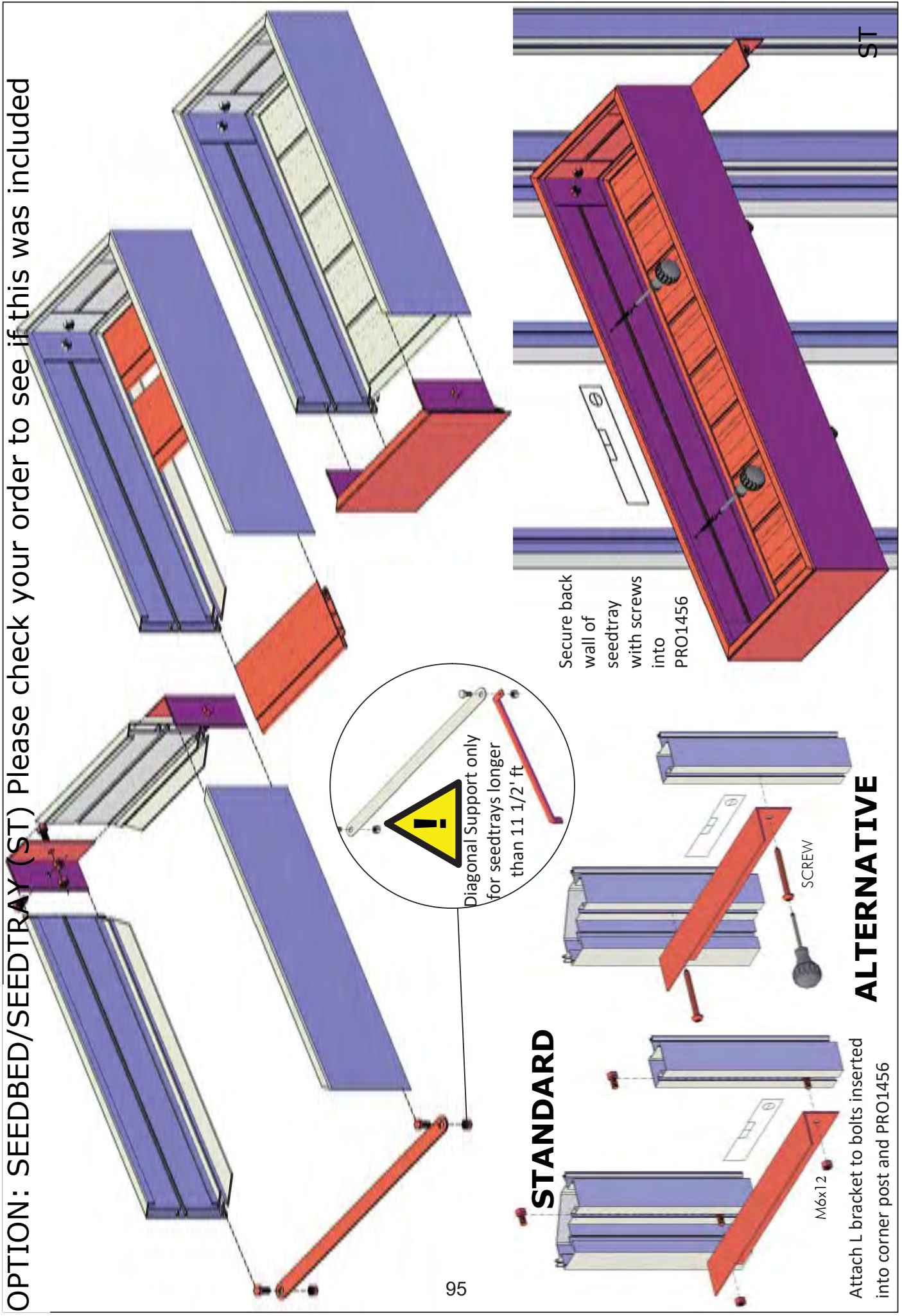

STANDARD

ALTERNATIVE

Secure back wall of seedtray with screws into PRO1456

Attach L bracket to bolts inserted into corner post and PRO1456

SCREW

M6x12

ST

OPTION: 2 Slat Shelf (TAB2)

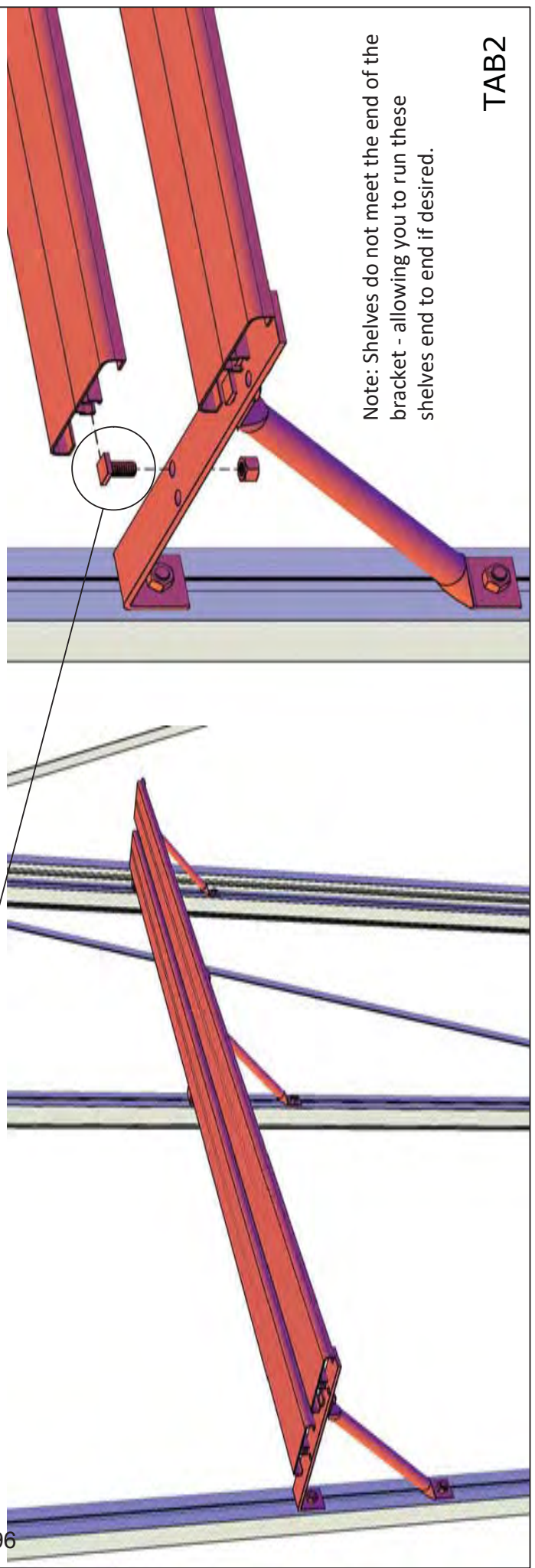
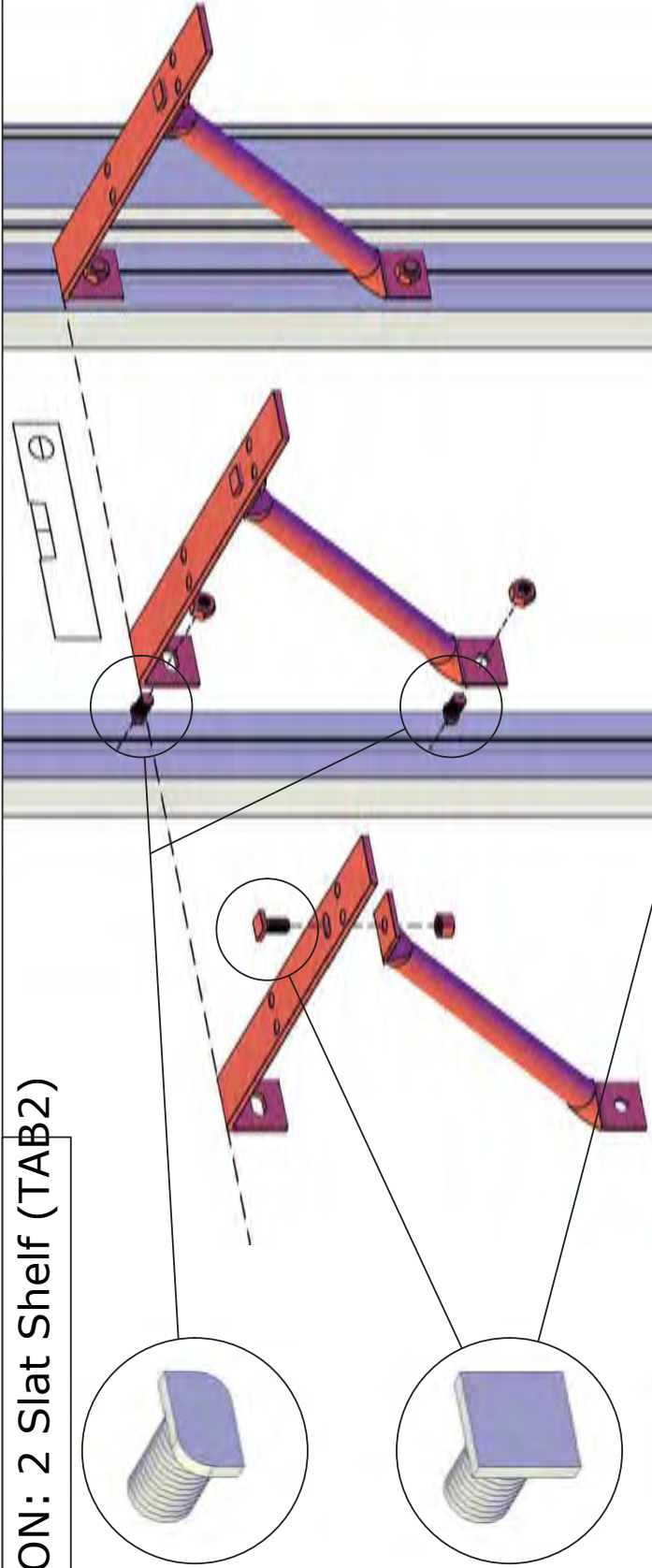

Note: Shelves do not meet the end of the bracket - allowing you to run these shelves end to end if desired.

TAB2

OPTION: 5 Slat Shelf (TAB5)

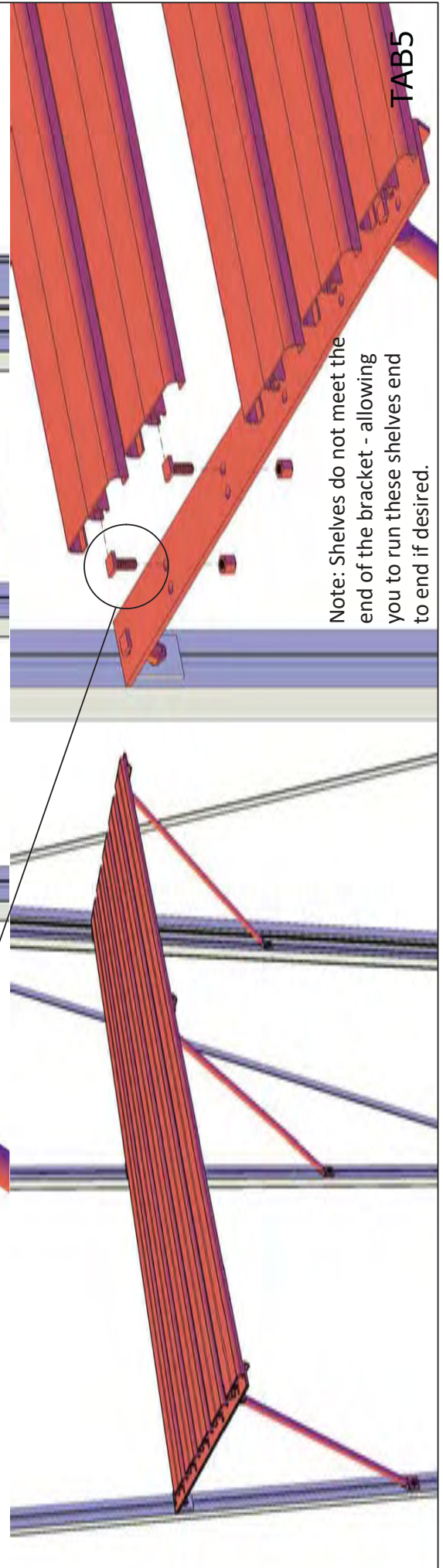
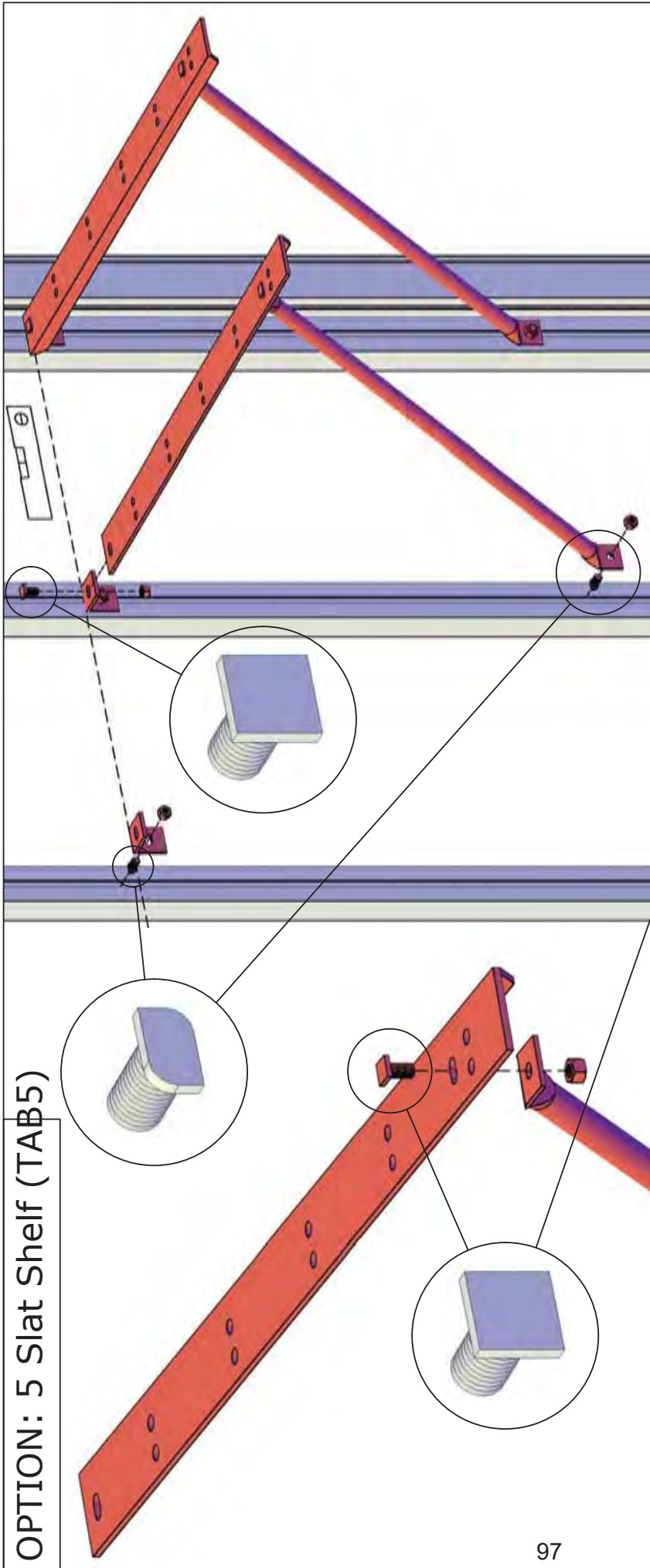

Note: Shelves do not meet the end of the bracket - allowing you to run these shelves end to end if desired.

TAB5

OPTIONAL ACCESSORY: SHADECLOTH (2 additional pages to follow)

Inserting the curlicue hooks into the curtain: The curlicue hooks that insert into the curtain will go in every 6th loop in the white ribbon— look at the picture diagram to ensure you are inserting them in the correct direction so the curtain hangs well. Your curtains will have one looped ribbon running across the center (for the ridge) and 3 white looped ribbons on either side. If you have a VI23 you will use the ribbons closest to the center, the VI34 and 36 as well as the Royal Orangerie use the center ribbons. The VI46 will use the ribbons closest to the edge. Please note in the 10 ft long curtains there are 2” gaps located about 30” in from each edge along the center ridge ribbon, this is not a defect. These gaps are intentional to allow for misting system support hooks (as needed) and diagonal supports (VI 34/36/46). **Please note: if you have forgotten to insert any items during assembly, you may “notch” the channel with a ½” drill bit in an inconspicuous place. We can send a touch up paint pen if you need one.**

VI 23 (7’9” x 10’2”) - One shadecloth section (SUN236-300). The misting system is best hung from one bolt/hook at one end of the shadecloth and through the intentional gap at the other side. This allows for the curtain to be gathered around one of the hooks when not needed. Insert the following in this order:

- In ridge profile:
 - 1 bolt (for L bracket that connects at gable end)
 - Twist lock (optional)
 - 30 Sliding Eye Hooks
 - Twist lock (optional)
 - 1 bolt (for L bracket that connects at gable end)
- In each gutter profile:
 - 1 Twist lock (optional)
 - 30 Sliding Eye Hooks
 - 1 Twist lock



VI 34 (10’2” x 15’) - Has three separate curtains – (2) SUN310-73 (these smaller sections fit between each gable end and the diagonal support) and (1) SUN310-300 (placed in the longer middle section). The misting system is best hung from 2 bolts/hooks placed next to each diagonal support so the larger curtain moves freely in the middle. Insert the following in this order:

- In ridge profile:
 - 1 bolt (for L bracket that connects at gable end)
 - 9 Sliding Eye Hooks
 - 1 bolt for diagonal support
 - 1 bolt for hook for misting system
 - Twist lock (optional)
 - 30 Sliding Eye Hooks
 - Twist lock (optional)
 - 1 bolt for hook for misting system
 - 1 bolt for diagonal support
 - 9 Sliding Eye Hooks
 - 1 bolt (for L bracket that connects at gable end)
- In each gutter profile:
 - 1 Twist lock (optional)
 - 48 Sliding Eye Hooks
 - 1 Twist lock

VI 36 (10’2” x 19’11”) and VI 46 (12’7” x 19’11”) -Shade cloths are (2) SUN310-300. The diagonal supports at the gable ends will be inserted through the intentional gaps in the shadecloth. The misting system is best supported by (3) bolts/hooks: one by each of the diagonal supports and one in the center. The VI 36 and VI 46 have additional “scroll” supports that are placed across the gutter and ridge profiles in the middle of the greenhouse – there is no hardware inserted in these profiles for the supports, but they will be mentioned. Insert the following in this order:

- In ridge profile:
 - 1 bolt (for L bracket that connects at gable end)
 - 9 Sliding Eye Hooks
 - 1 bolt for diagonal support
 - 1 bolt for hook for misting system
 - 20 Sliding Eye Hooks
 - Twist lock (optional)
 - 1 bolt for hook for misting system
 - Space for “scroll” support
 - 1 Twist lock (optional)
 - 20 Sliding Eye Hooks
 - 1 bolt for hook for misting system
 - 1 bolt for diagonal support
 - 9 Sliding Eye Hooks
 - 1 bolt (for L bracket that connects at gable end)
- In each gutter profile:
 - 1 Twist lock (optional)
 - 30 Sliding Eye Hooks
 - Space for “scroll” support
 - 30 Sliding Eye Hooks
 - 1 Twist lock (optional)

OPTION: Shadecloth (please see next page as well)

TYPE	SUN236_73	SUN310_73	SUN236_300	SUN310_300
	24 pcs	24 pcs	93 pcs	93 pcs
	24 pcs	24 pcs	93 pcs	93 pcs

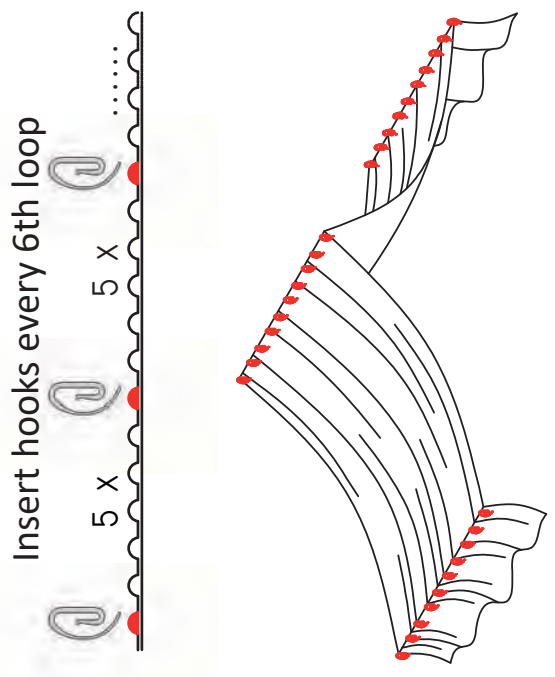
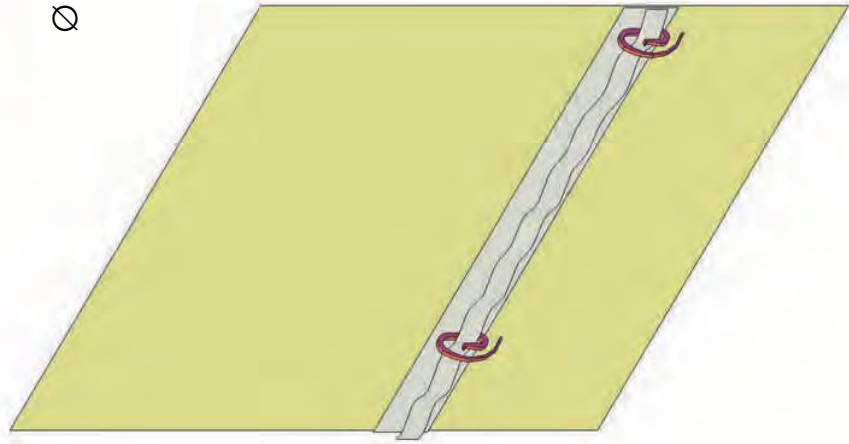
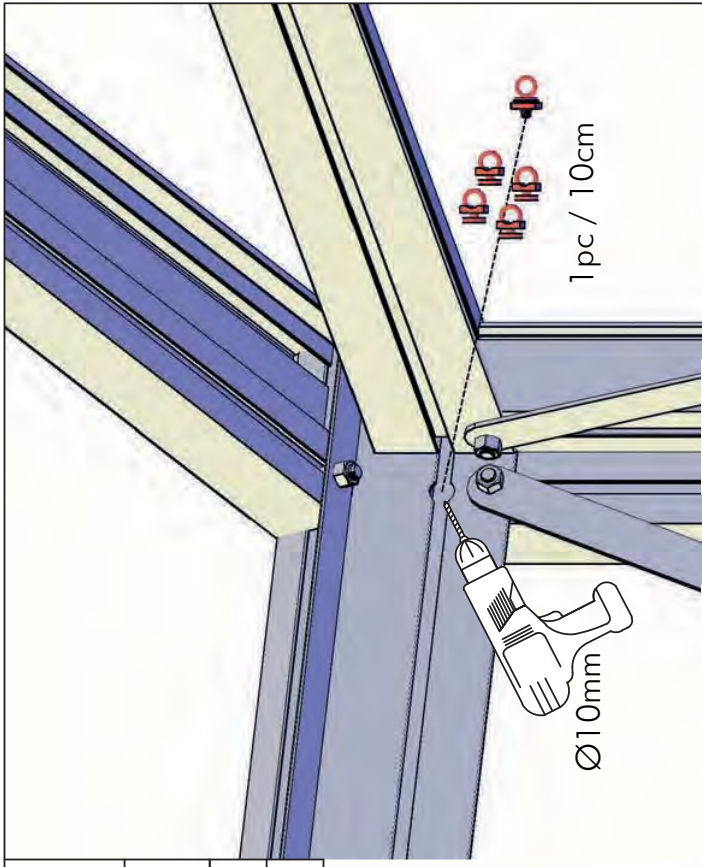
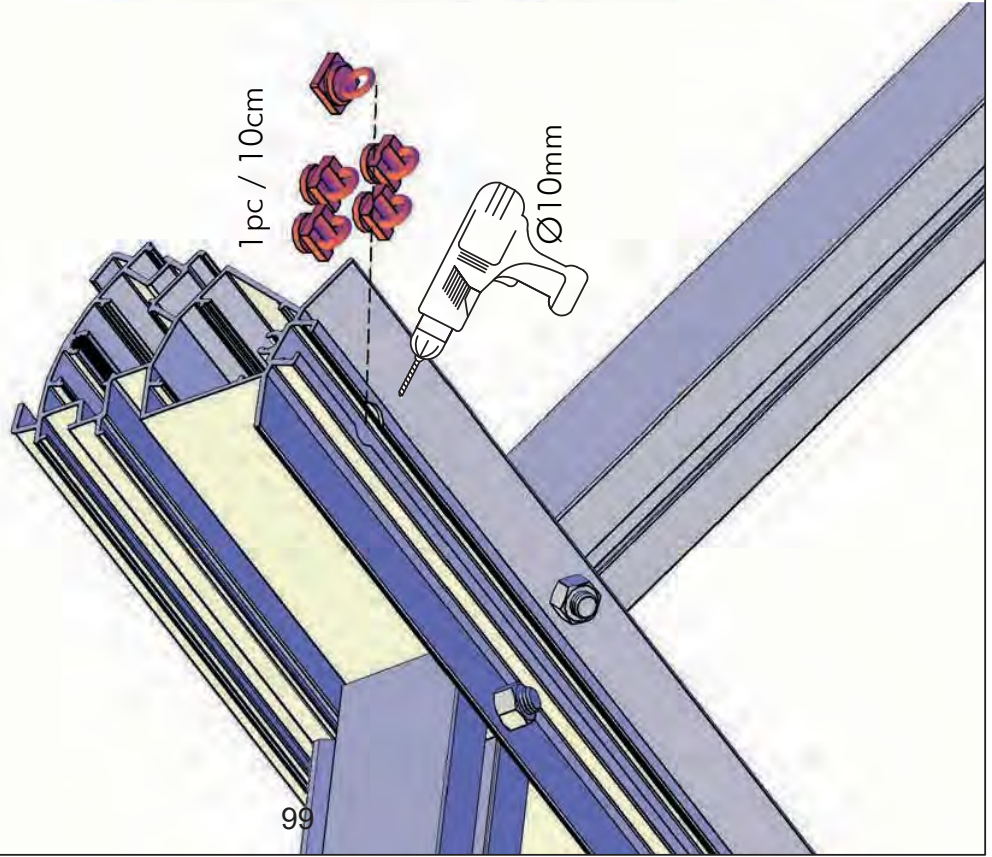

VICTORIAN CURTAIN GUIDE

VI 23

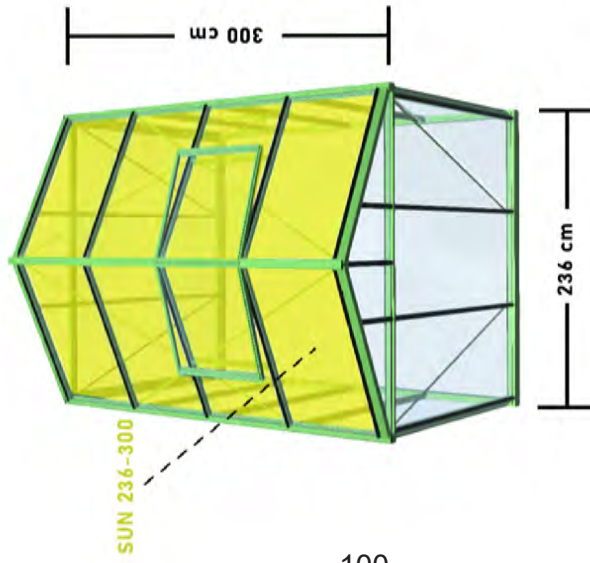

VI 34

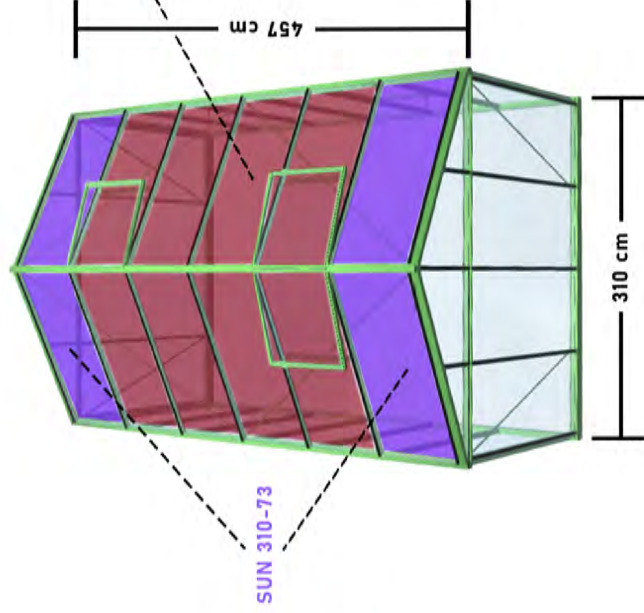

VI 36/46

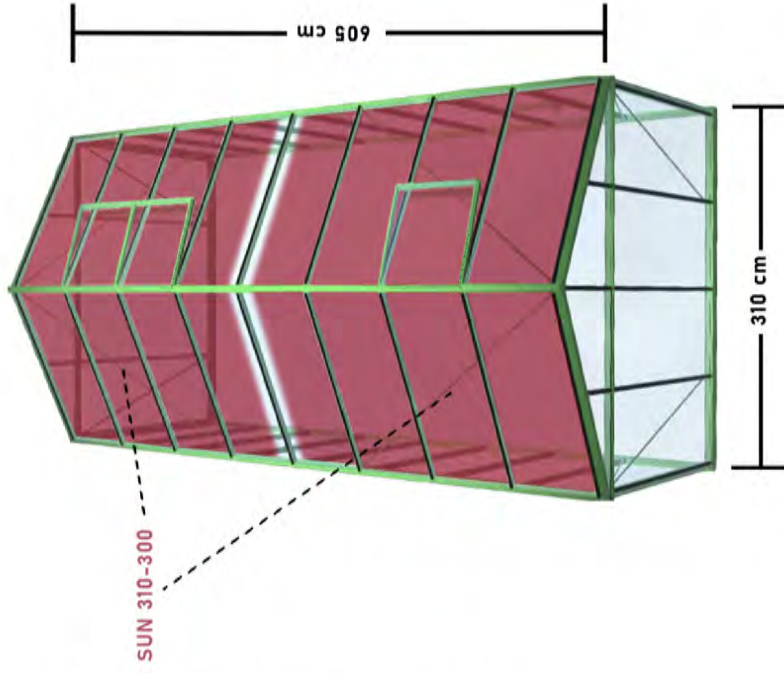







VI 23: Is one shade cloth section of **SUN236-300**

VI 34: Is one shade cloth section of **SUN310-300** and two shade cloth sections of **SUN310-73**

VI 36/46: Is two shade cloth sections of **SUN310-300**

Misting System (If Equipped)

Vi23 Vi34/36
TYPE 310 458

	3X	4X
	1X	1X
	1X	1X
	2300	3300
	2X	3X
	1X	1X



Note: If curtains are going to be installed, the misting system should be hung with bolts as shown to the left. The hangers will need top to be bent into position.

If there are no curtains it can be hung by drilling holes and hooking the hangers through them. (Shown below)

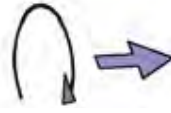

Most users find it easiest to attach a garden hose with a garden hose timer to the end of the misting. You will need a kit like the one pictured below (available at home improvement/garden stores). You will then trim the threading off you hose and attach the hose to the nozzle, slide the clamp on and tighten.

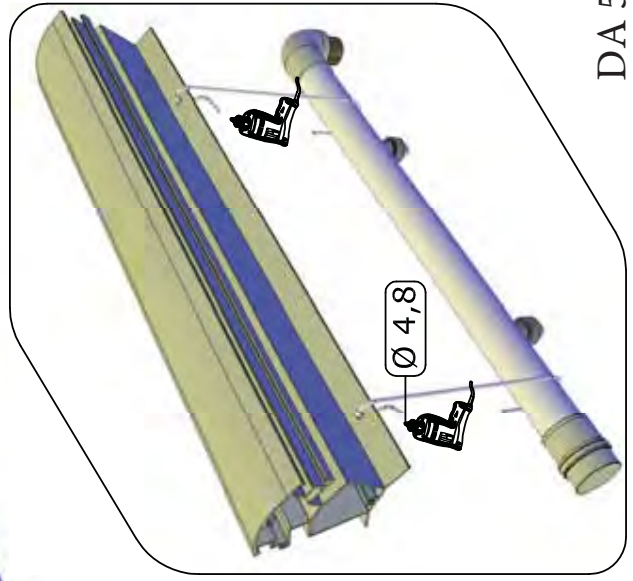
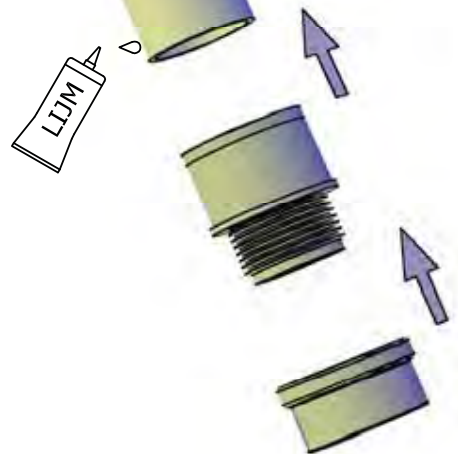
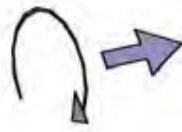
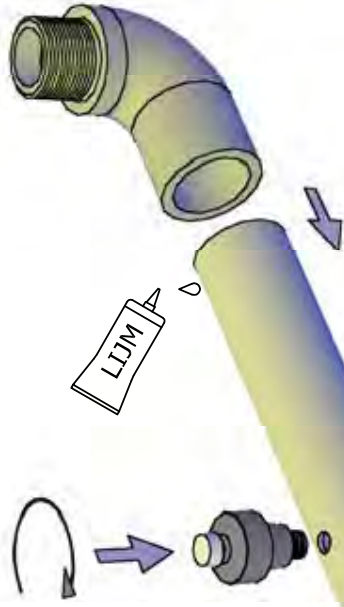

INSTALLING AN EXHAUST FAN IN A VICTORIAN GREENHOUSE

The exhaust fan in a Victorian Greenhouse should be installed up high in one of the gable ends of the greenhouse. If you happen to have polycarbonate walls on your Victorian, you may cut an opening in the polycarbonate to accommodate the fan. If you have glass glazing, we recommend replacing one of your upper angled gable panes with a piece of Lexan. We do offer a pre-cut panel for purchase that is cut with this unusual shape (with a square cut out) that will replace one of the gable panes of glass.

OPTION 1: Attach fan with bolts inserted into channel of PRO1456



Once your panel with the cutout for the fan is in place, mount the fan on the interior of the greenhouse using bolts in the channels of the aluminum extrusions. These bolts will fit through the holes on the exhaust fan. You may need to cut the corner off due to the diagonal support beam being in the way. Once the fan is mounted on two sides to the aluminum extrusions caulk around the area where the box of the shutters meets the glazing.

Option 2: Attach with self-tapping screws

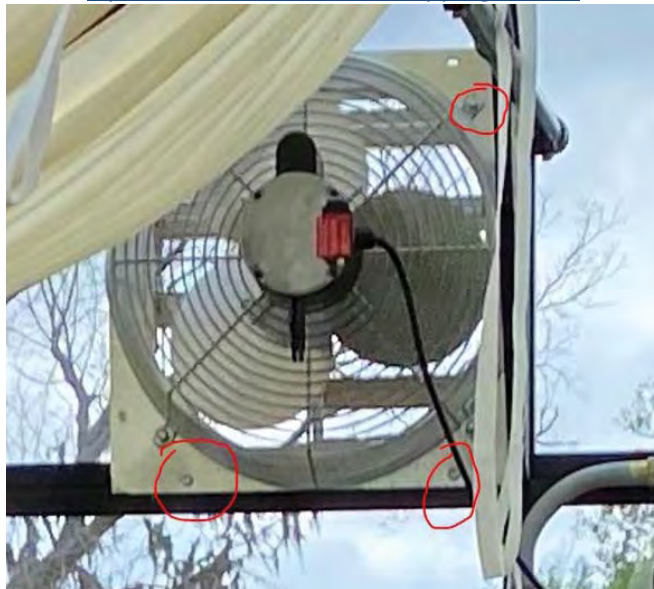

Conversely, you can use self-tapping screws to hold the Exhaust Fan in place. Pre-drill holes in the exhaust fan metal to match up with the Pro1456 Gable piece. You may need to cut the corner off due to the diagonal support beam being in the way. Once the fan is mounted on two sides to the aluminum extrusions caulk around the area where the box of the shutters meets the glazing.



Customer Service or
Assembly Questions?

Give us a call
Toll free: 1-877-760-8500
customerservice@exaco.com
Exaco Trading
www.EXACO.com

*Please watch our animated assembly
video on our Exaco Trading Co
YouTube Channel.
Find the link at www.exaco.com*

Janssens NV Mechelsesteenweg 388, B-2500 Lier Belgium
(T) +32 15 30 67 80 (W) www.janssens-alusystems.be (E) info@janssens-alusystems.be