

atlantis cabana

Adding a dramatic sense of style to any setting has never been easier. The Atlantis Cabana is an impressive combination of TUUCI's distinctive style and customary utility. Topped with a vector vent and flanked with ample drapes in high-performance marine-grade fabric, the Atlantis is built with an Armor-Wall™ aluminum marine alloy frame. It can be secured directly to a deck or in portable bases to create the perfect temporary or permanent outdoor room.

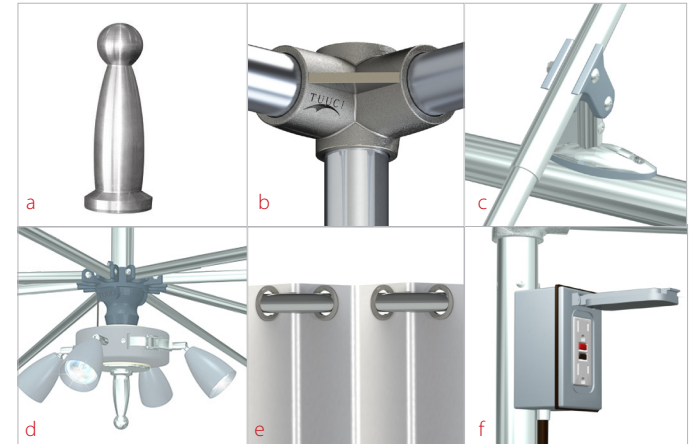

features:

- a. Venice Aluminum Finial
- b. Armor-Wall Mast
- c. Reinforced Strut Joints
- d. Aluminum Construction w/ Stainless Steel Components
- e. Stainless Steel Curtain Rings, Grommets and Clips
- f. Optional Pre-Wired Junction Box

shapes & sizes



square

ft.	/	m.
8.0'	/	2.45
9.0'	/	2.75
**10.0'	/	3.0
**11.0'	/	3.4



rectangle

ft.	/	m.
**8' x 12'	/	2.45 x 3.65

side wall option / curtains



accent curtains



full curtains

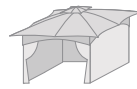

tensioned fabric walls



tensioned fabric walls with windows



1 tensioned back wall & full curtains

**includes highwind stabilizers

global headquarters
2900 NW 35th Street, Miami, FL 33142 USA | 305.634.5116 | info@tuuci.com

european office
Nedervonder 17, 5061 JP Oisterwijk, The Netherlands | +31.13.522.0471 | info@tuuci.eu

atlantis cabana *in dura-teak finish*

The Atlantis cabana in dura-teak finish takes everything we love about the Atlantis, but goes a step further by using Dura-TEAK™ wood-grain polymer frame construction. This state-of-the-art polymer resin is impervious to saltwater and UV degradation. The result is a frame that looks like wood yet won't rot, peel, rust or crumble and is completely resistant to acid rain for years of little-to-no maintenance. The Atlantis cabana in dura-teak finish can be secured directly to a deck or in portable bases to create a perfect temporary or permanent outdoor room.



shapes & sizes



square

ft. / m.
8.0' / 2.4
9.0' / 2.7
**10.0' / 3.1
**11.0' / 3.4



rectangle

ft. / m.
**8' x 12' / 2.4 x 3.7

side wall options / curtains



accent curtains



full curtains



tensioned privacy wall

finish options

dura-teak finish



natural

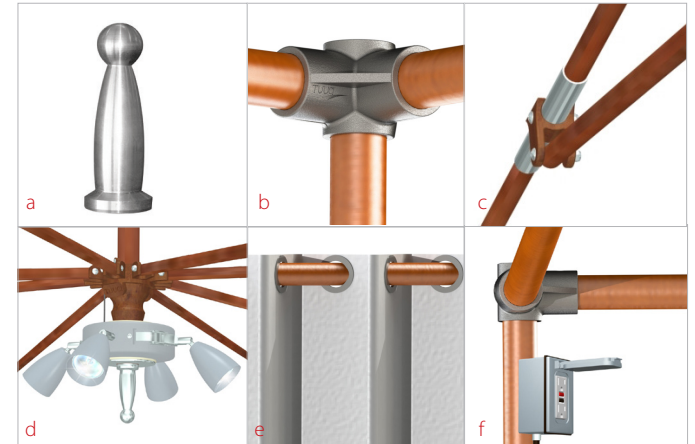

features:

- a. Venice Aluminum Finial
- b. Dura-TEAK Armor-Wall Mast
- c. Reinforced Strut Joints
- d. Dura-TEAK Aluminum Construction w/ Stainless Steel Components
- e. Stainless Steel Curtain Rings, Grommets and Clips
- f. Optional Pre-Wired Junction Box

**includes highwind stabilizers

global headquarters
2900 NW 35th Street, Miami, FL 33142 USA | 305.634.5116 | info@tuuci.com

european office
Nedervonder 17, 5061 JP Oisterwijk, The Netherlands | +31.13.522.0471 | info@tuuci.eu

v.06.13.17

tuuci.com