

WARNING: Failure to follow installation and hitch-up instructions may cause property loss, serious injury, or death!

CAUTION: Under no circumstances do we recommend exceeding the towing vehicle manufacturers recommended vehicle towing and load capacity.

READ ALL INSTRUCTIONS BEFORE STARTING THE INSTALLATION

Equipment Required:
M13 Socket
Torque Wrench
Lithium Grease

NOTE: It is recommended that you start with the M5 Leg Instructions.

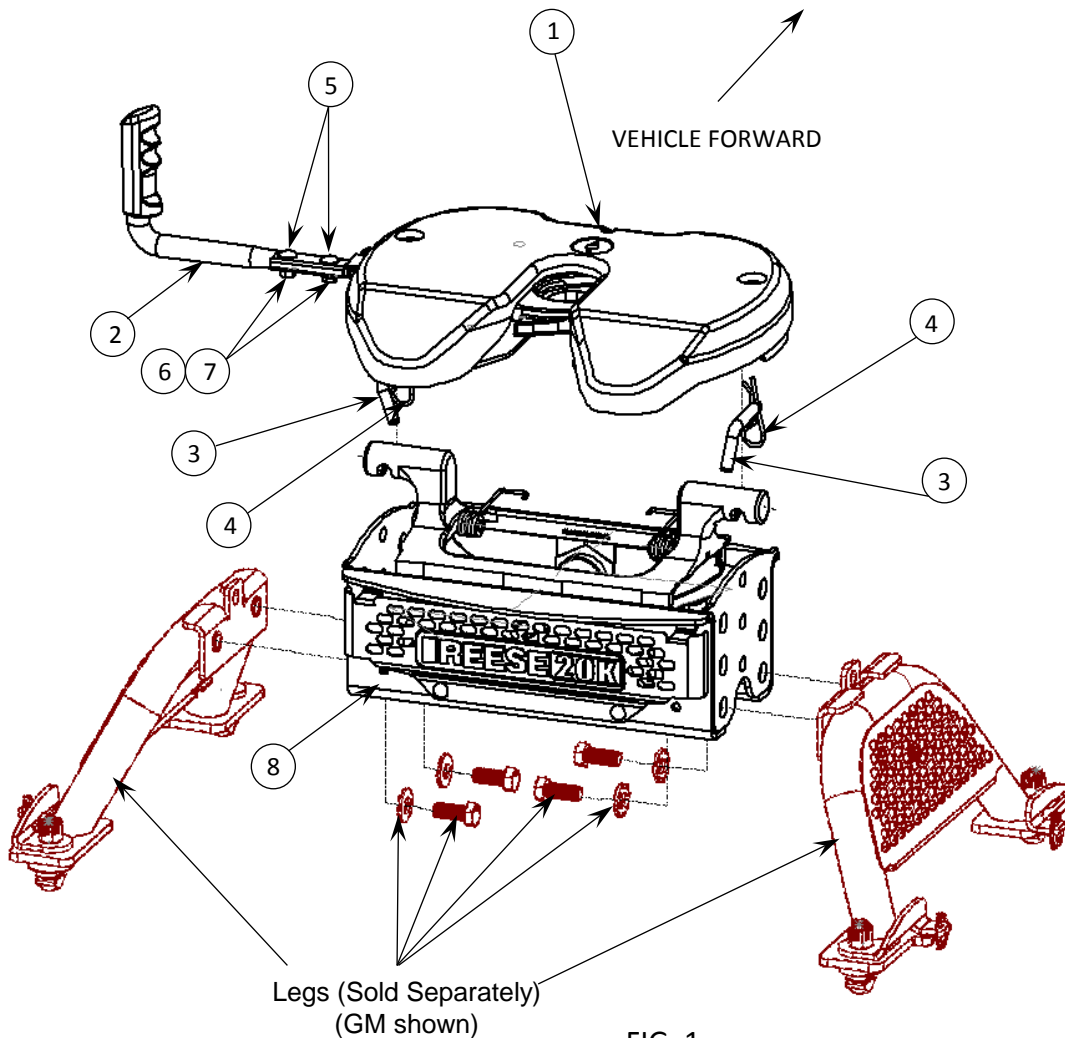

#	Description	Qty.
1	M5 Head Unit (30892)	1
2	Handle	1
3	½" Pull Pin	2
4	Spring Clip	2
5	M8 Carriage Bolt	2
6	M8 Lock Washer	2
7	M8 Nut	2
8	M5 Center Section (30884)	1

FIG. 1

Table of Contents

Installation	p 2	- Handle Position Overview	p 7
- Assembly	p 2	- Hitching	p 8
- Added clearance to Cab	p 3	- Pull Test	p 8
- Guidelines for matching hitch, truck, and trailer	p 4	- Unhitching	p 9
Use Instructions	p 7	- Maintenance	p 10

*Note: Leg Assembly instructions can be found under their individual part number

ASSEMBLY

Handle Assembly

- Slide handle over the bar as shown in figure 2, and securely tighten with carriage bolts, lock washers and nuts with M13 wrench. Handle should be snug.

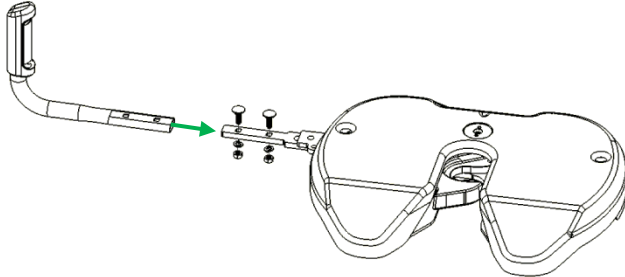

FIG. 2

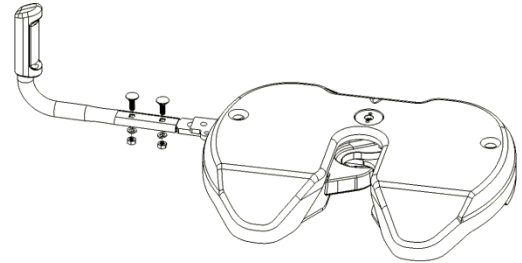

FIG. 3

Center Section Attachment to Legs

- Fasteners and assembly instructions are included with the M5 Leg Structure, **sold separately**.
- For height adjustment, the unit should be set to have a minimum of 6" clearance between the truck bed rail and the bottom of the trailer. This unit has 3 possible attachment locations, with 4" of overall adjustment.

NOTICE: Failure to adjust and monitor gap between truck bed and trailer may lead to property damage.

- For added clearance to the truck cab, see page 7.

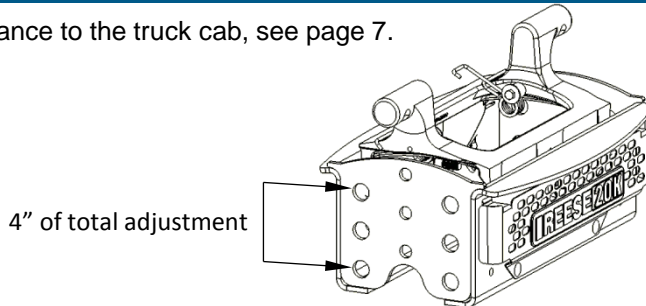

FIG. 4

Head Attachment to Center Section

- In order to ensure quiet performance, apply grease per page 3, figure 9A. Place head unit on top of center section. Insert pull pin as shown in figure 6, and secure with spring clips. Both sides required.

CAUTION: Avoid putting any body parts in pinch point areas (Fig 5)

- Inspect through sight holes on top of head unit to make sure clips are assembled correctly, as shown in figure 7.

WARNING: Failure to install both pull pins and clips may lead to property damage, injury, or death.

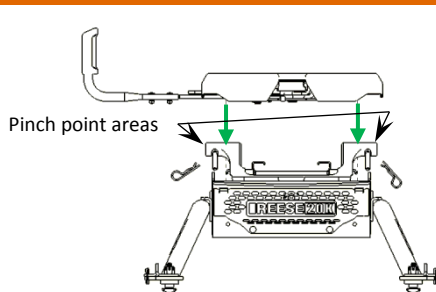

FIG. 5

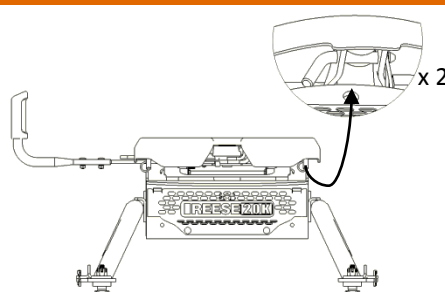

FIG. 6

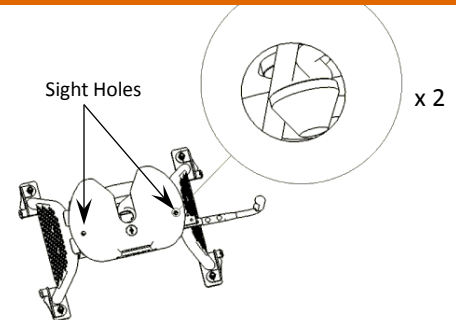

FIG. 7

TO INCREASE THE GAP BETWEEN TRAILER AND TRUCK CAB by 1-1/2".

The center section has an option to increase the gap between the trailer front and the truck cab by 1-1/2" by rotating the center section 180 degrees. Whenever possible, it is recommended to locate the king pin ahead of truck rear axle and maintain proper truck cab clearance.

1. Remove the head by pulling the spring clips off the head retainer pins. Then pull the head retainer pin out of the head.

NOTICE: A slight push down on the head will help to pull the head retainer pin out.

CAUTION: Avoid getting fingers pinched in pinch point areas.

2. Lift the head off and set aside.
3. Remove the bolts holding the legs on the center section and rotate the center section (all vehicles), **OR** disconnect the feet from the bed and rotate the center section and leg assembly (not possible with RAM vehicles).
4. Re connect the center section or the center section and leg assembly per the installation instructions of that portion.
5. Remove the logo/rating cover by gently prying the two lower plastic retainers with the cover away from the center section. Avoid scratching the paint by using plastic auto trim tools. The top will pivot and pull away once the cover rotates up enough.
6. Re-install on the other side (truck rear) by reversing the above process.
7. Remove the head springs by removing the 1/4" bolt (7/16" socket) and flip them from right to left. When installed properly, the springs should be pointing up towards the truck cab and tighten to 7-8 ft-lbs. Springs will flex freely.
8. Re apply grease to the head and center section interface and re-install the head per instructions.

CAUTION: Place hands or fingers on either side of the pivot interface to prevent pinching.

9. Re-install head retainer pins and clips per head instructions.

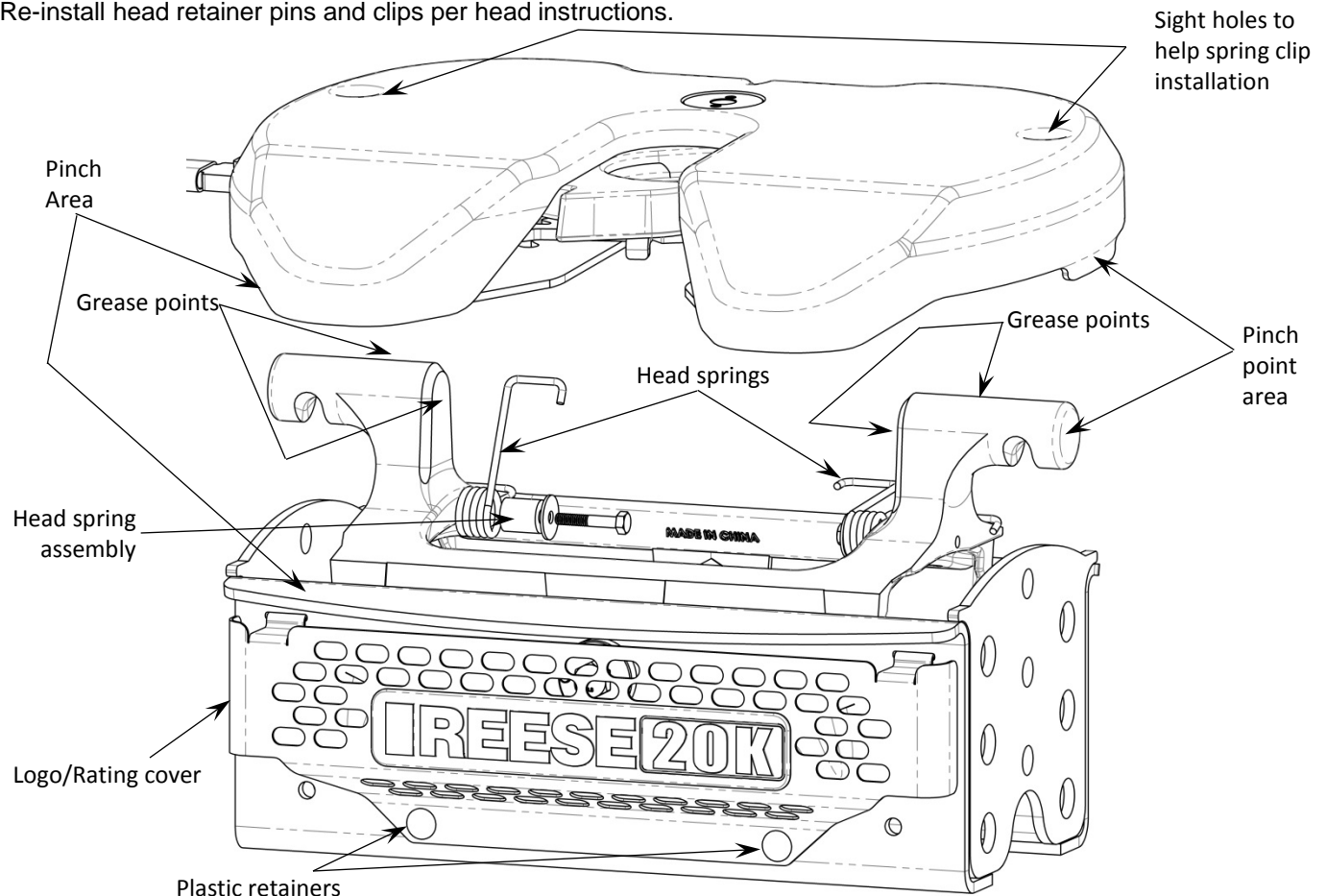

FIG. 18

Shown in factory location with offset towards cab of truck

GUIDELINES FOR MATCHING HITCH, TRUCK, AND TRAILER**WARNING:**

Failure to check and follow tow ratings could result in tow vehicle damage or truck and trailer separation while towing.

- Trailer and its contents together must not exceed truck, hitch (leg, center section, and head unit) and/or trailer tow ratings.
- Towing vehicle must have a manufacturer's rated towing capacity equal to or greater than the gross trailer weight (dry weight of the trailer plus payload of the trailer). (See Fig. 16)
- Gross weight of trailer must not exceed 20,000 lbs.
- King pin weight must not exceed 5000 lbs. If in doubt have king pin weight measured by qualified facility.

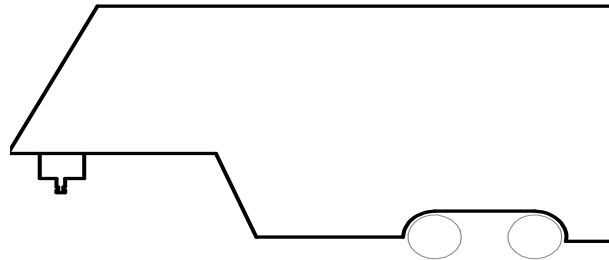
Figure 16

FACTORY TRAILER + FULL WATER
TANKS + CARGO, ETC.
= GROSS TRAILER WEIGHT

1. Check Tow Ratings:

Vehicle Tow Rating: _____

M-Series Hitch Rating: _____ 20,000 lbs. _____

Gross Trailer Weight (Figure 16): _____

*Trailer weight should be the lowest of these recorded ratings for safe towing conditions.

2. Reese hitches are designed for use with recreational fifth wheel trailers only.

3. Use only a SAE 2-inch king pin with your M-Series Fifth Wheel Hitch.

4. Approximately 15%-25% of trailer weight should be on hitch (Pin Weight). See Fig. 17.

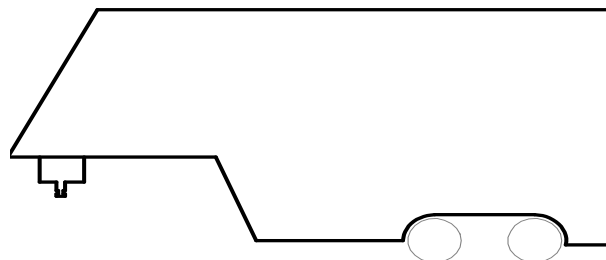
Figure 17

15-25%
GROSS TRAILER
WEIGHT
(PIN WEIGHT)

75-85%
GROSS TRAILER
WEIGHT

5. Trucks come in many different configurations. Reese's M-Series hitch is designed for use in light trucks such as the GMC Sierra and Chevrolet Silverado. We recommend the use of long bed (8ft) light trucks for the best combination in truck - trailer turning clearance.

NOTICE: The distance from the back of the truck cab to the center of the rear truck axle ("X" in Fig. 18), should be approximately 4 inches greater than one-half the trailer width ("Y" in Fig.18)

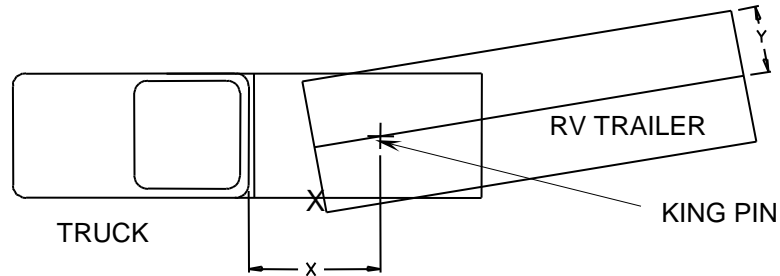
Figure 18

6. If a short bed pickup (less than 8 ft. but longer than 6 ft.) is to be used for towing, Reese recommends the trailer be equipped with a minimum 13" extended pin box to help gain additional truck - trailer turning clearance (See trailer manufacturer for options) (See Fig. 19).

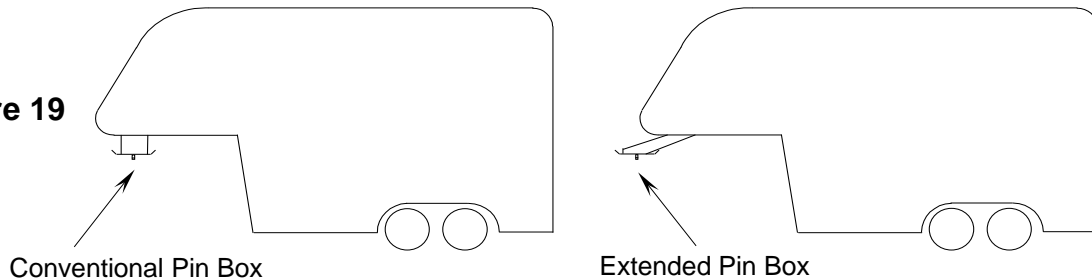
Figure 19

WARNING: Do Not install this fifth wheel hitch on or attempt to tow with a short bed pickup truck that has a bed shorter than 6 ft. Unless you use a REESE Sidewinder or Revolution Pin Box. Doing so could result in vehicle damage, serious injury, or death.

7. The height of the hitch and the pin box should be adjusted so the trailer is approximately level as it is towed. Allow approximately 6 inches clearance between the top of the pickup walls and the underside of the front of the trailer for pitch and roll of the trailer. (See Fig. 20). For off road use allow more clearance between pickup walls and trailer.

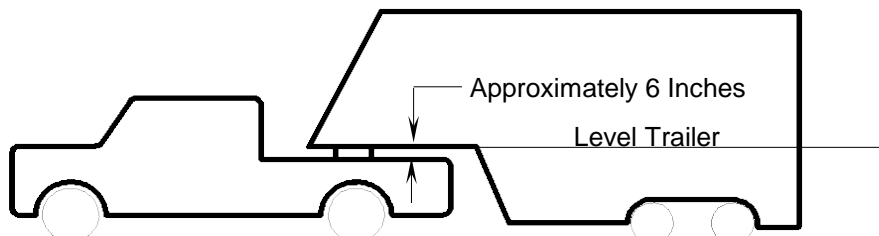
Figure 20

GUIDELINES FOR MATCHING HITCH, TRUCK, AND TRAILER

8. Hitch height determination:

- I. With trailer leveled and on level ground measure from the ground to the king pin box, "A" in Figure 21.
- II. Measure from the height of the inside of the truck bed, "B" in Figure 21. Dimensions "C" and "D" in Figure 21 can be used to determine the amount of clearance over the side rails, as mentioned in step 7.

$$\text{Hitch Height} = A - B + 2''$$

The 2" value is an estimate of suspension compression due to king pin weight of the trailer. This compression could range between 1"-5" depending on the truck being used and the trailer being towed.

$D - C + 2'' > 6''$ as stated in step 7.

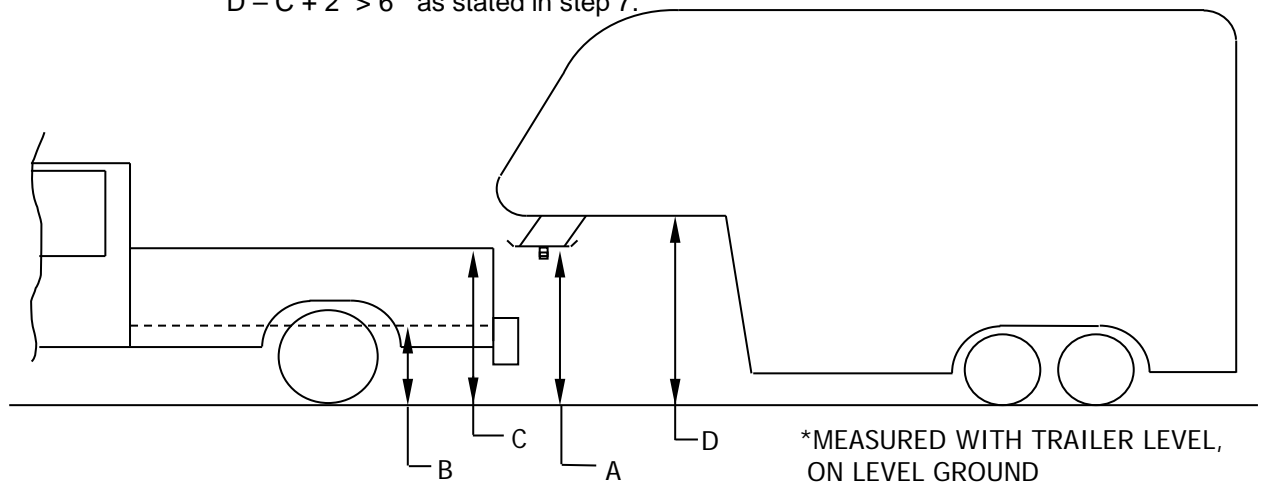
**Figure 21**

9. If a lube plate is to be used with an Elite Series 5th Wheel it must be at least 12" in diameter and not more than 3/16" thick. Reese offers this optional lube plate as part # 83001.

WARNING:

- Connection for trailer wiring must be located at the side of the truck bed between the driver's seat and the rear wheel to prevent operators from working between the truck and trailer.
- Avoid putting any part of your body under the trailer or between the truck and trailer. Unexpected or accidental movement of the truck or the trailer can cause serious injury or death
- If you must place any part of your body under the trailer or between the truck and trailer you **MUST** perform **ALL** of the following steps:
 - Check that the truck transmission is in park
 - Check that the emergency brake is set
 - Block in front of and behind all trailer tires
 - Check that the trailer landing gear are resting on firm ground

HANDLE POSITION OVERVIEW

Ready-to-Receive Position:

When will the head be in this position?

- When delivered
- When hitch not in use
- When coupling to trailer
- After uncoupling from trailer

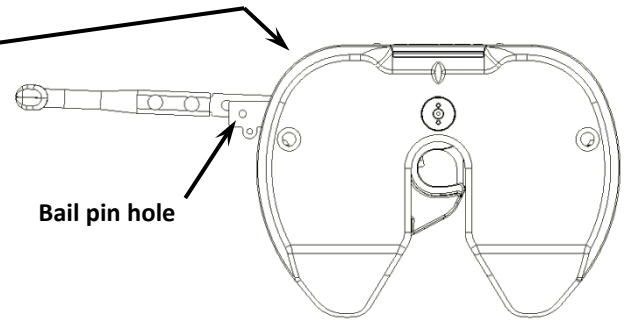
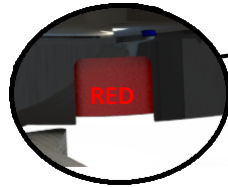

FIG. 10

How to tell the head is in this position:

- Handle is pulled out so holes do not align for bail pin
- Handle is easily movable towards cab, and returns to default position upon release
- Indicator shows **RED**

Latched Position:

When will the head be in this position?

- When latched to trailer

How to tell the head is in this position:

- Handle is in a position where holes align for bail pin insertion.
- Indicator shows 100% **GREEN**

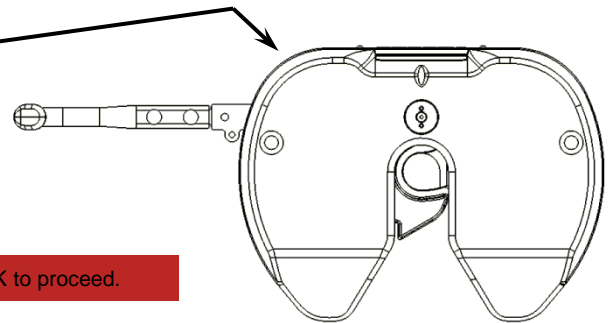
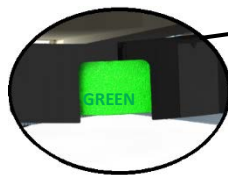

FIG. 11

DANGER: Any partial indicator position (Red and Green) means that it is NOT OK to proceed.

Unhitching Position:

When will the head be in this position?

- When unhitching the trailer

How to tell the head is in this position:

- Handle is in position shown*
- Indicator shows **RED**

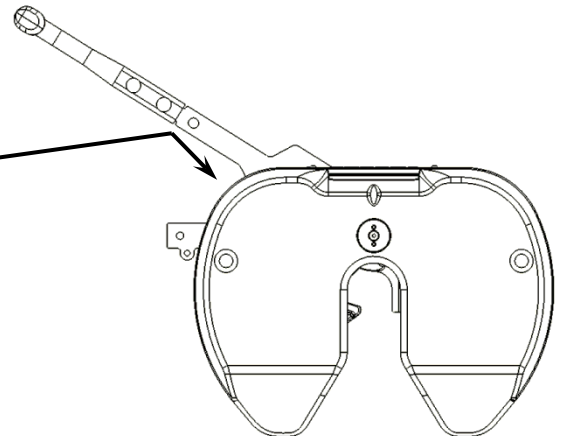
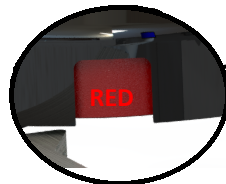

FIG. 12

NOTICE: If there is tension between truck and trailer, the truck or trailer may shift when handle is pulled. In this case, handle will start to return to ready-to-receive position, but trailer will still uncoupled.

HITCHING PROCEDURE

Before hitching to a trailer, make sure your 5th wheel hitch height is correct. Guidelines on how to properly set the height of your 5th wheel hitch can be found in the on page 5.

WARNING: Failure to follow these instructions may result in property damage, serious injury, or death.

1. Make sure the truck and trailer are in position to couple
 - A. 5th wheel hitch is correctly secured to truck
 - B. Truck tailgate is lowered if necessary
 - C. Blocks/Chocks are firmly against each trailer wheel to prevent any possible forward or rearward motion.
 - D. Pin box is at correct height for hitching (fig. 13 & 14).
 - E. Make sure head is in Ready-to-Receive position (pg. 4, fig.10)

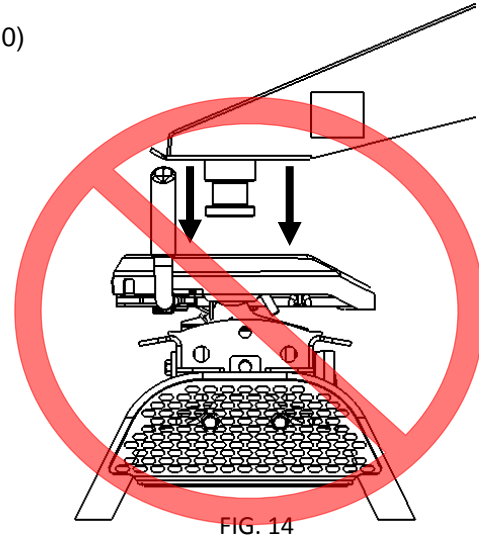
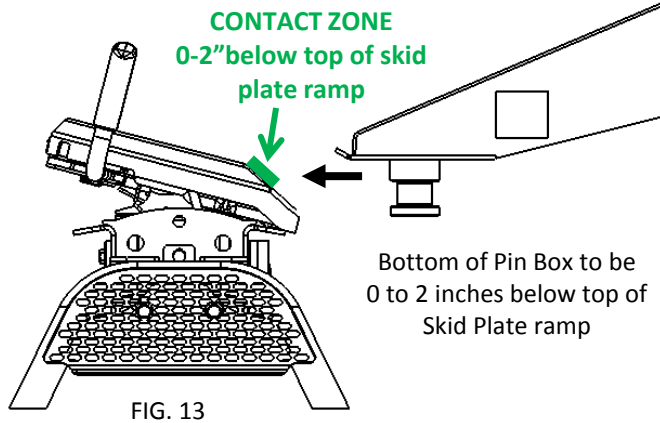

2. Back truck slowly into trailer so the trailer king pin and 5th wheel funnel align. Hitch will latch automatically when truck is backed completely into trailer king pin. When this occurs, the indicator will be 100% green (pg. 4, fig. 11).*
3. Perform Pull Test
 - A. With trailer wheels still firmly blocked, trailer landing gears firmly on the ground supporting trailer weight, and trailer brake on, make sure no one is between the truck and trailer.
 - B. Try to pull trailer slowly forward. If trailer is properly hitched, proceed to Step 4. If trailer is not properly hitched, trailer will separate from hitch, and truck will move forward - Repeat steps 1 thru 3.
4. Insert bail pin into bail pin hole, as shown in figure 15, or lock for added security. Possible lock dimensions shown on page 10.

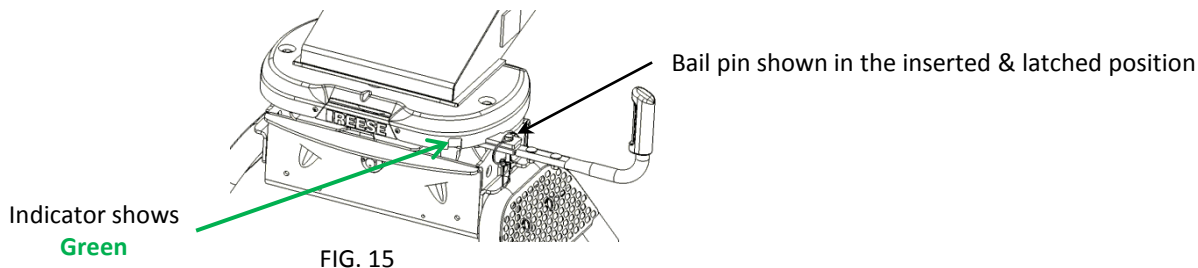

1. Connect electrical cable and breakaway switch cable between truck and trailer, raise tailgate as necessary.
2. Remove chocks/blocks and lift trailer jacks.

*Jaw may not close if it is under high compression load. If fully backed into trailer and not fully latched, pull truck slightly forward to remove load on jaw. Handle will latch automatically.

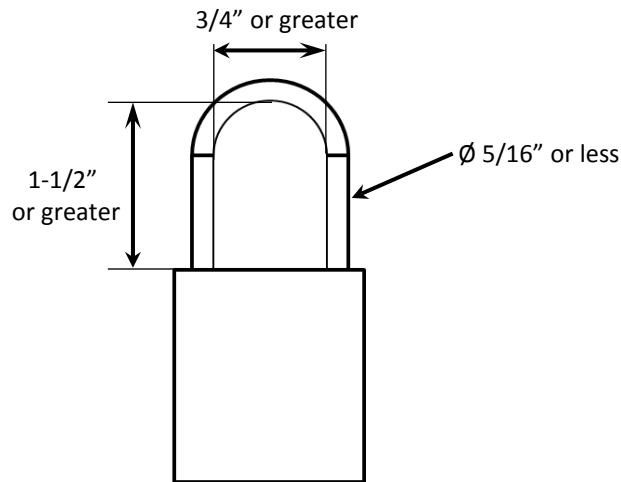
POTENTIAL LOCK DIMENSIONS**Unhitching Procedure**

WARNING: Failure to follow these instructions may result in property damage, serious injury, or death.

- 1) Make sure trailer is secure:
 - A. Blocks/Chocks are firmly against each trailer wheel to prevent any possible forward or rearward motion.
 - B. Trailer jacks are lowered and are firmly on the ground
- 2) Make sure truck is ready to unhitch:
 - A. Tailgate is lowered as necessary.
 - B. Electrical cable and breakaway switch cable are disconnected.
- 3) As truck and trailer may shift when unhitching, ensure no person or vehicle is in the vicinity of truck or trailer when unhitching.
- 4) Remove bail pin from locking hole, and move handle to unhitching position (fig. 17) by pulling out and pushing handle towards cab.*

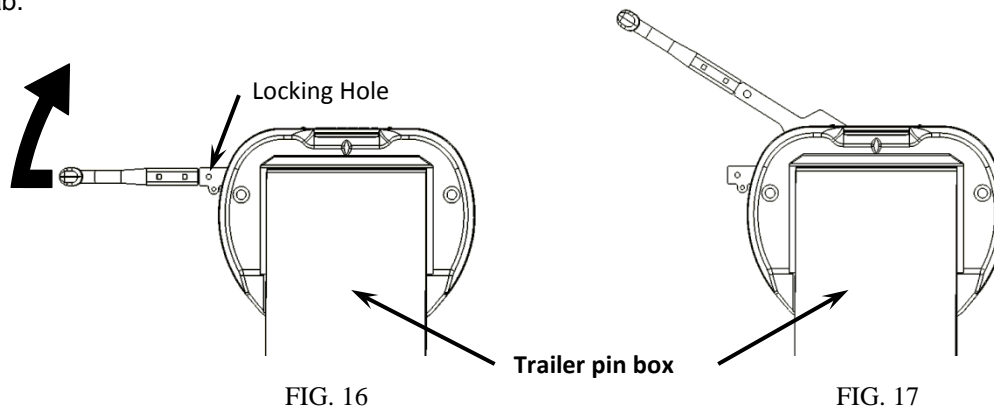

- 5) Drive truck forward, slowly away from trailer.

*If there is tension between the truck and trailer, the truck or trailer may shift when handle is pulled. In this case, handle will start to return to ready-to-receive position, but trailer will still uncouple.

MAINTENANCE

This unit is designed to need very little maintenance and be one of the quietest on the market. In order to ensure long term performance, it is recommended to lubricate as indicated below;

Every Use

1. Apply grease to skid plate surface, to provide lubricated surface for attachment to trailer.
Note: Plastic lube plates can be used to avoid messy grease. Plate must not exceed 3/16" in thickness to ensure hitch works properly. REESE 5th Wheel Lube Plate #83001 is recommended.
2. Apply grease to 5th wheel jaw and/or kingpin on the trailer.

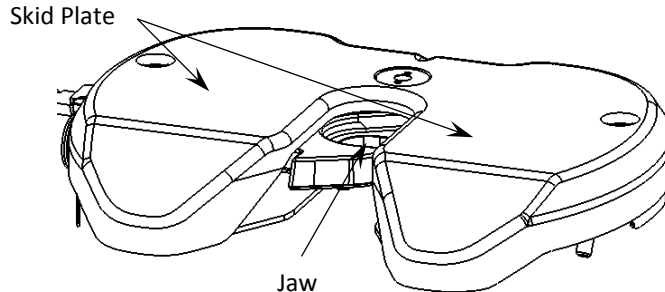

FIG. 8

Annually/As Required

1. Apply grease via the grease fitting on the top of the unit. (Grease needle required). Head comes pre-greased
2. Apply spray-on lithium grease to internal mechanisms - rotate handle a few times to distribute the lubricant.
Note: May need to wipe down unit to remove large debris before application of grease.
3. Greasing the pivot assemblies can easily be done with a grease gun that has a needle adapter installed.
4. The pivot assembly resistance is preset at factory. If head pivots and makes noise when trailer is not attached, adjust the resistance by tightening pivot bolt 1/2 turn at a time (2 full turns max.). See figure 9B.
5. The pivot assembly can be rebuilt if required. Instructions to do this will be in rebuild kit.

