



Soft Rooftop Tent RE Manual

Save this manual for future reference. Read and understand all instructions and safety precautions before use.



WARNING

Improper installation or use of your Roof Top Tent may result in serious injury or death. Follow these installation instructions carefully to ensure proper installation on your vehicle and for safe use of your Roof Top Tent. Please contact your vehicle manufacturer for specified loading capacity of your roof rack. Not all factory roof racks or aftermarket roof bars can safely accommodate tent models.

ANY ELEMENTS APPLIED ON THE VEHICLE ROOF CHANGES THE NORMAL VEHICLE HANDLING. THE MANUFACTURER DISCLAIMS ANY AND ALL RESPONSIBILITY IN THE CASE OF ACCIDENTS DUE TO IMPROPER USE, INCORRECT MAINTENANCE, OR NOT CHECKING THE TIGHTNESS OF THE FASTENING HARDWARE/ BRACKETS ON THE ROOF RACK SYSTEM

DO NOT CLIMB ON LADDER UNTIL CORRECT ANGLE IS ACHIEVED (approx. 60 degrees between ladder and ground).

NOTE: If the angle of the ladder is at 90 degrees and/or does not reach the ground, you will need a ladder extension or longer extendable ladder (sold separately, contact your distributor).

The wholesaler / manufacturer shall not be liable for special, indirect, incidental, or consequential damages including but not limited to lost profits.



WARNING

KEEP ALL FLAME AND HEAT SOURCES AWAY FROM THIS TENT. This tent is not fireproof. The fabric will burn if left in continuous contact with a flame source.

PRECAUTIONS

Do NOT use candles, matches or other open flames in or near a tent.

Fuel-powered lanterns and appliances are **NOT** recommended for use in or near a tent. If fuel-powered lanterns or appliances such as wood stoves or electric heaters are used, **exercise extreme caution**. Keep them away from the tent walls.

Do NOT leave them unattended. Turn them off before going to sleep. Make sure the tent is well ventilated at all times to avoid suffocation.

Build campfires downwind and several metres away from a tent. Extinguish campfires before leaving a campsite or going to sleep.

Do NOT fuel lamps, heaters or stoves in a tent.

Do NOT smoke in a tent.

Do NOT store flammable liquids in a tent.

Keep exits clear.

Do NOT apply any foreign substance to a tent. It may diminish the flame resistant properties of tent material(s).

VERIFY YOUR VEHICLE'S ROOF STRENGTH

This Roof Top Tent weighs 50kg.

Check your vehicle owner's manual or with the vehicle manufacturer to determine the vehicle's maximum effective roof load.

The maximum load on the roof of the vehicle must be observed. Determination of the effective roof load: weight of the roof bars + weight of the Roof Top Tent = effective roof load.





DO NOT transport additional items inside, attached to, or on top of the Roof Top Tent.

INSPECTION

Prior to beginning any trip with the Roof Top Tent installed on your vehicle, ensure that all nuts and bolts that attach the Roof Top Tent are tight and in good repair.

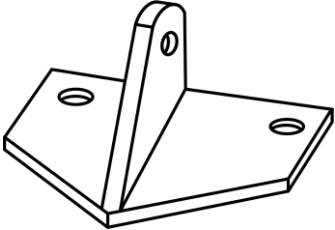
During the trip, regularly check that all fasteners continue to be tight and have not become loose.

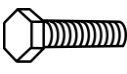
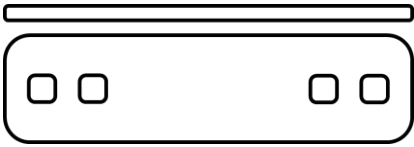
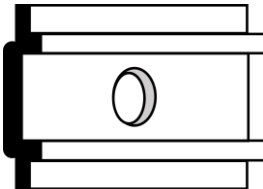
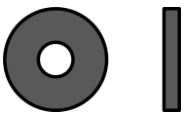
ROOF TOP TENT HARDWARE IDENTIFICATION CHART

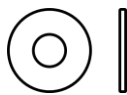
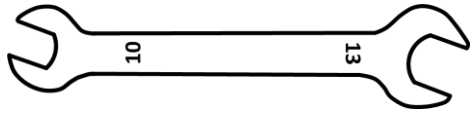
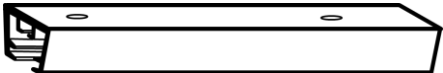
<u>Item</u>	<u>Description</u>	<u>Qty</u>	
1	Ladder Mounting Bracket	2	
2	55mm Stainless Steel M8 Bolt	8	
3	40mm Stainless Steel M6 Bolt	8	
4	16mm Stainless Steel M6 Bolt	2	
5	Stainless Steel Mounting Plate	4	
6	Aluminum Slide Plate	8	
7	Rubber Washer (for Ladder)	2	
8	M8 Self-Locking Nut	8	
9	M6 Self-Locking Nut	10	
10	Stainless Steel Washer	20	
11	Metric Wrench 10/13 mm	2	
12	Mounting Channel	2	

Attaching the Mounting Rails to the Roof Top Tent

Direction of Opening

Before you fit your Roof Top Tent to your vehicle, you will need to decide whether you wish to have the tent open to the back or to the side of the vehicle.

A. Opening to the Back

For most larger vehicles (SUVs), opening to the back is preferable. The advantages of this orientation are:

- Leaves extra roof space for additional storage.
- With the tent open, you will gain weather protection from the tent above your head when accessing the back of your vehicle.

The mounting channels will need to be cut off at both ends prior to being fitted to the base of the rooftop tent.

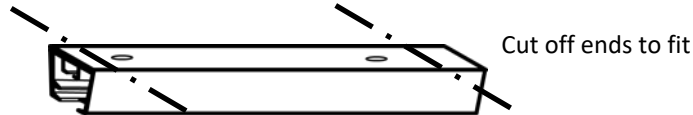

The mounting channels are then bolted to the base of the tent at right angles to the roof rack or roof bars, in the direction of opening (along the length of the tent base).



B. Opening to the Side

For most medium (like a Jeep Wrangler) or small vehicles, opening off the side is preferable. The advantages of this orientation are:

- Allows for tailgates to operate normally.
- Means the closed tent pack is better balanced on the roof and creates less wind drag as the narrow face of the tent pack is traveling forward.

The mounting channels bolt to the base of the tent at right angles to the roof rack or roof bars (across the width of the tent base).

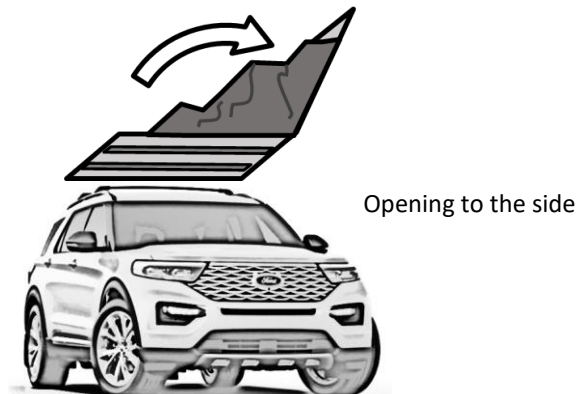

Attach the Mounting Channels to the Base of the Roof Top Tent

(Numbers in parenthesis refer to the Roof top tent hardware identification chart)

1. Remove the Roof Top Tent from the carton and place it on a clean surface. Observe the top surface. If it has four holes in the center area of the base, then this is the channel mounting surface. Otherwise, you are viewing the side that will receive the ladder. Open the tent and remove the hardware from the inside. The contents consist of the following items:

Ladder	1 pc
PVC Cover	1 pc
Window Rod	8 pcs

Mounting Channel	2 pcs
Mounting Accessories	1 bag

2. Close the Roof Top Tent so the channel mounting surface as described above is facing upward, then remove the plugs that are covering the holes.
3. Place a stainless steel washer (Item 10) on each of four 40 mm Stainless Steel M6 Bolts (Item 3). Use your hand to slide between the base and the mattress and insert a bolt with washer into each hole so that the bolt head is inside the tent below the mattress.
4. Place the Mounting Channels (Item 12) onto the protruding bolt threads. As discussed previously, if your orientation is to be Opening to the Back, ensure the Mounting Channels are parallel to the tent hinge. (Note: when mounting the channels for Opening to the Back orientation, the channels will need to be trimmed. Mark the channel ends and cut so it is flush with the base.) Otherwise, if your orientation is to be Opening to the Side, ensure the Mounting Channels are perpendicular to the tent hinge.
5. Individually slide an M6 Self-Locking Nut (Item 9) into the inner slot at the center of the Mounting Channel with the flat part of the nut towards the tent base. Align the nut with the protruding bolt thread and use the 10mm Metric Wrench (Item 11) to tighten firmly.

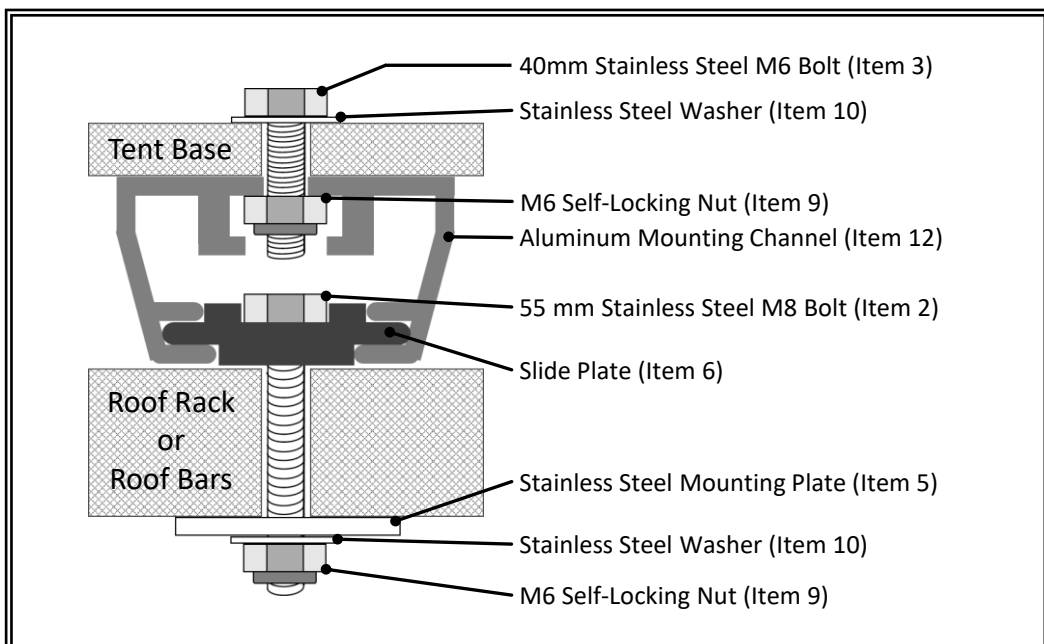

Mounting Diagram

Attach the Ladder to the Base of the Roof Top Tent

(Numbers in parenthesis refer to the Roof top tent hardware identification chart)

1. Once the Mounting Channels have been installed, and with the tent folded, turn the tent over so the Mounting Channels are underneath take care not to cause damage to the Mounting Channels.

2. Locate the pre-drilled holes at the edge of the base, opposite the hinge, and use four 40 mm Stainless Steel M6 Bolts (Item 3) to attach the Ladder Mounting Brackets. Place a washer on the protruding bolt threads then install an M6 Self-Locking Nut (Item 9). Secure the brackets in place by tightening the bolt and nut using the Wrenches (Item 11).

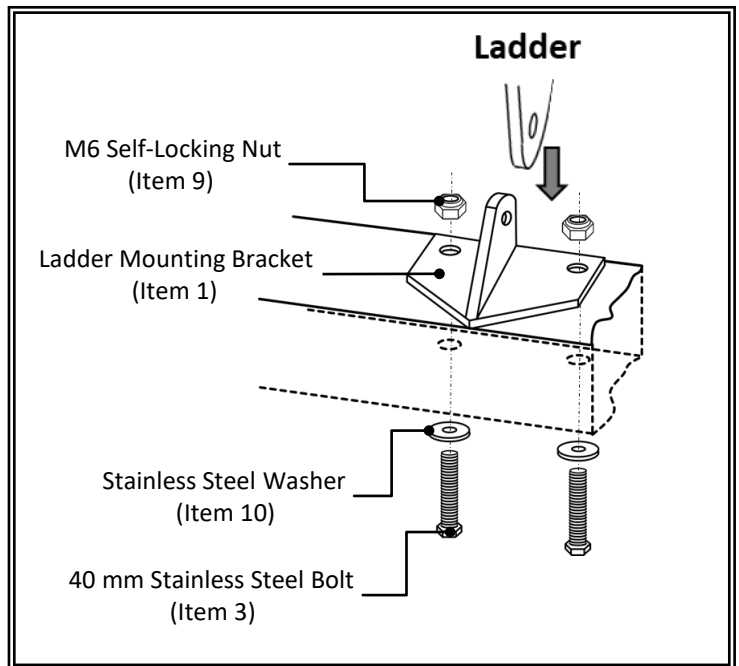

3. Once the Ladder Mounting Brackets are secured in place, lay the ladder on the base of the tent and align the holes on the tabs of the ladder to the holes in the tabs on the Ladder Mounting Bracket.
4. Put a Rubber Washer (Item 7) between each set of tabs, then place a stainless steel washer (Item 10) on each of two 16mm Stainless Steel M6 Bolts (Item 4) and insert the bolt through the tab holes.
5. Place a M6 Self-Locking Nut on the bolt threads and use the Wrenches (Item 11) to tighten.
6. Test that the ladder can pivot on the tabs. If it is too tight, loosen the nut by 1/8 to 1/4 turn.

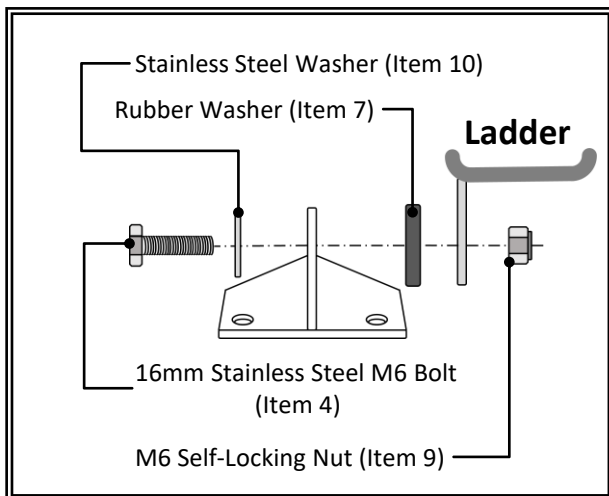

Installing the Roof Top Tent onto your Roof Rack or Roof Bars

(Numbers in parenthesis refer to the Roof top tent hardware identification chart)

1. Ensure the vehicle is parked in a safe, flat spot. Use a minimum of two people, or a mechanical advantage system, to lift the Roof Top Tent and place onto the vehicle's roof rack or roof bars.
2. Insert a 55 mm Stainless Steel M8 Bolt (Item 2) into each of the eight Aluminum Slide Plates. Slide two slide plates into each of the Mounting Channels on one side of the vehicle, lift the roof top tent and slide them so the two plates and bolts are on the inside edge of the roof rack or roof bars. Repeat this for the other side. Then slide two more plates into each of the Mounting Channels so these two plates and bolts are on the outside edge of the roof rack or roof bars. Repeat this for the other side. Refer to the Mounting Diagram and ensure the slide plates are inserted correctly.
3. Check that the position of the Roof Top Tent is centered on the roof rack and that it is positioned to open on the desired side. Adjust the position as necessary.

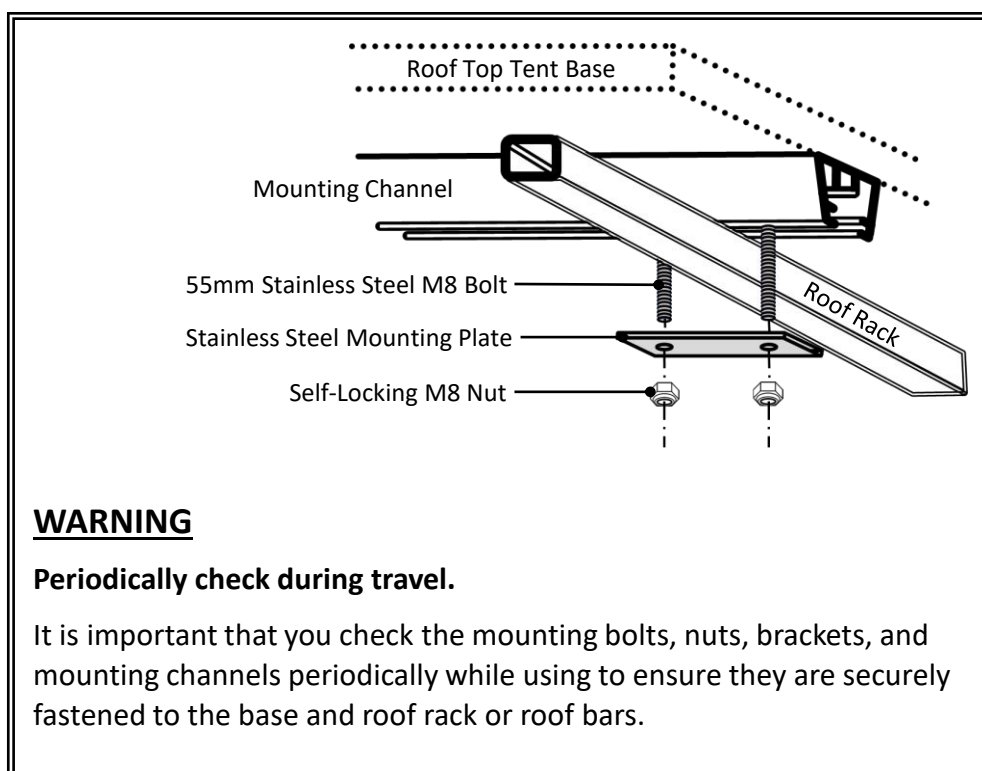

4. Attach the Roof Top Tent to your roof rack at the four points where the rack and Mounting Channels cross. Place a Stainless Steel Mounting Plate (Item 5) onto the protruding 55mm Stainless Steel M8 Bolts (Item 2) then place a M8 Self-Locking Nut (Item 8) onto the threads of each bolt. Use a Wrench (Item 11) to tighten all eight nuts, but do not over-tighten.
5. After ensuring the Roof Top Tent is positioned correctly, and all eight nuts are tightened, insert the rubber end caps into the ends of the mounting channel (this may require light tapping using a mallet).



WARNING

Do Not Install this tent onto an open frame structure.

The Roof Top Tent is not designed to be installed onto a truck bed rack or on any vehicle which allows for a great amount of airflow underneath the tent base. The amount of force applied to the base of the Roof Top Tent as caused by this increase of airflow will cause the mounting hardware to fail. The manufacturer shall not be held liable for any Roof Top Tent installed this way.

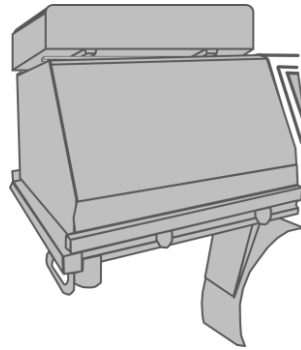

WARNING

Do Not Use the ladder at the incorrect angle.

The Ladder on the Roof Top Tent is designed to act as a brace and provide some support to the suspended base of the tent with an angle of approximately 60° relative to the ground. For your safety, DO NOT climb on the ladder if it is at 90° or at an angle less than approximately 60°. If the angle of the ladder is 90° and/or does not reach the ground, a ladder extension (not included) will be necessary. If the angle is too low, the ladder may need to be shortened by drilling additional holes above the existing locking pin holes. NEVER ADD HOLES BELOW THE EXISTING LOCKING HOLES. This will weaken the ladder and it will fail.

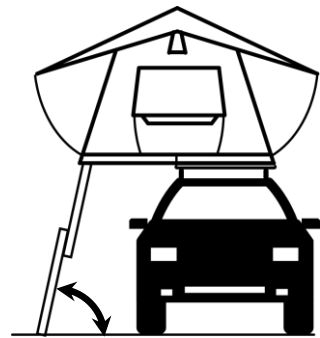
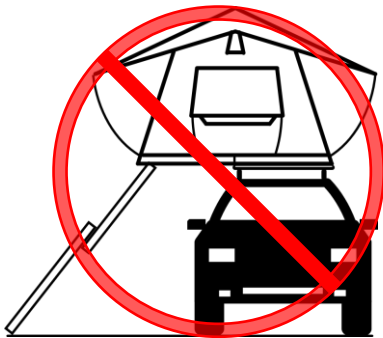

60° 



WARNING

Drive with Caution.

Any weight carried on the vehicle will adversely affect its handling particularly in cornering or in a cross wind and the vehicle should therefore be driven with increased caution.



WARNING

Do Not transport additional items inside the Roof Top Tent.

Additional items may shift or place excessive strain on the tent hinge which will cause damage. Properly store only original items that are used in your tent.

Set Up the Roof Top Tent

1. Park the vehicle on level ground and set the parking brake.
2. Remove the cover from the tent.
3. Release the hold down straps on the sides.
4. Slide the ladder out until the locking pins engage, then use the ladder as a lever to assist in opening the tent.
5. Adjust the ladder length so it is touching the ground and at an acceptable angle (approximately 60° relative to the ground). If the angle is too vertical, or if the ladder does not touch the ground, a ladder extension (not included) will be needed. Contact your distributor. If the angle is too small, shorten the ladder by changing to a different locking pin hole. If there is not a locking pin hole for the height needed, adjust the ladder to the correct angle, mark then drill new locking pin holes. NEVER ADD HOLES BELOW THE EXISTING LOCKING HOLES. This will weaken the ladder and it will fail.

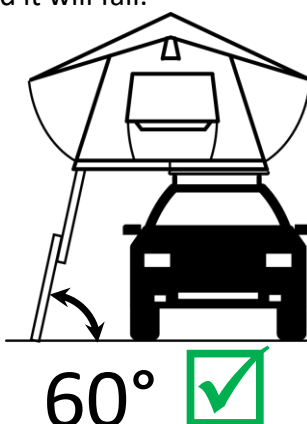

6. Install the rain fly by inserting the rain fly poles into the pockets on the sides of the tent, then tighten the straps on the rainfly.
7. Install the window rods on the rain fly and window shades. The window rods are designed to have tension and will have a “bow” when installed.
8. Unzip and roll up the screens and covers as desired. Use the hasps to hold them up.

Packing the Rooftop Tent

Follow the above steps in reverse order.



WARNING

The maximum capacity of this tent is 300kg (660lbs).

The tent will support up to 300kg after the vehicle is stopped, placed in park mode, with the parking brake set and with the tent properly set up. Overloading may cause injury or damage to the tent or vehicle.



WARNING

Always properly stow the tent prior to driving.

Never drive with a set up tent. Properly stow the tent and ensure the cover is fastened securely in place prior to driving.



WARNING

Always assist children and the infirm when using the ladder.

Do not let children use the ladder without supervision. A fall from small heights may result in serious injury. Use the straps to assist when entering the tent.

Additional Precautions for the Roof Top Tent

- When stowing the tent, it is unnecessary to use excessive force on the side retaining straps. These straps are only used to hold the tent base together and if excessive force is used to PULL the base together with these straps, they may fail.
- Try to avoid stowing the tent when wet. If you must stow the tent when wet, zip all doors and windows closed to try and prevent the inside of the tent from becoming wet. As soon as possible, and in a dry area, open the tent and allow it to thoroughly dry out to prevent mold and deterioration. Always ensure the tent is completely dry prior to any extended period of stowage.
- With a properly installed and stowed Roof Top Tent on a vehicle, the overall height of the vehicle is increased. Make note of the vehicle height and use caution when driving in areas with low overhangs.

Off-Vehicle Long Term Storage

- When storing off-vehicle, always ensure the tent is completely dry and stored in a dry area.
- Do not drag the stowed tent on the ground, doing so may damage the base or top.
- Avoid storing the stowed tent directly on the ground or concrete. If necessary, use wood blocks underneath the stowed tent to keep it from direct contact.

Care Instructions

- Clean only with cold water and a soft brush. Do not use soap, detergents, or bleach.
- Do not expose the tent to fuel, oil, or solvents.
- A new tent may experience weeping through the seams or fabric. This is normal and will stop after the fabric cures.
- The tent fabric may wear and lose its water-proofing over time. Re-proofing with a suitable waterproofing solution is recommended.



WARNING

BENEHIKE ("Manufacturer") warrants, to the original purchaser ("User") that its rooftop tent, if purchased from manufacturer or an authorized distributor or dealer, will be free of defects in material and/or workmanship under normal usage from the date sold and for the duration (the "Warranty Period") of 2 YEARS. This warranty shall ONLY be effective for the original purchaser and apply ONLY to the BENEHIKE rooftop tent that is correctly installed on the vehicle for which it is intended. BENEHIKE will either replace the product or provide you with a refund at our discretion provided that the fault is found to have been caused by a design or manufacturing defect that results in its failure to perform correctly as described. The limited warranty is the only one that applies to this product, and it sets forth all the responsibilities of BENEHIKE



WARNING

This warranty does not cover defects, failure or damage caused by incorrect installation, intentional damage, misuse or abuse. It is recommended that the installation should be performed by suitably qualified technicians or the warranty will be voided. For further clarity, this warranty is also void if the rooftop tent: is repaired, altered or modified carried out by anyone other than BENEHIKE, or without BENEHIKE's authorization, is damaged by mold and mildew as the tent is not properly dried prior to closing, is damaged by extreme weather (e.g. storm, hail or strong wind), extreme temperature, accidents, negligence, daily wear and tear, incorrect setup, or failure to check the condition of tent before each use, is damaged by UV degradation or acid rain to the tent/awning and its components, is damaged from improper storage, or a failure to provide routine maintenance, is used on permanent sites or commercial displays.



WARNING

If a BENEHIKE product is suspected of being defective, you'll need to provide proof of purchase (e.g. a screenshot of the order) and a picture and a video of the damaged goods in their entirety to service@benehike.com. If the product is found to be defective and covered by this limited warranty, the remedy is replacement or refund, at BENEHIKE's option. No charges will be accepted for external labour or materials.