

powermaster

SG

Slide Gate Operator for use in Commercial and Industrial Applications for gates up to 50' wide and 1,500 lbs. Use for up to 30 cycles per hour.

STANDARD FEATURES

- AVAILABLE IN SINGLE OR THREE PHASE
- SOLID STATE CONTROL BOARD WITH DIAGNOSTIC LEDS TO INDICATE ALL INPUT & OUTPUT FUNCTION
- ON BOARD, 3-BUTTON CONTROL STATION
- TIMER TO CLOSE WITH 0-60 SECOND ADJUSTMENTS
- SELF ADJUSTING MAXIMUM RUN TIMER
- EASY LEFT/RIGHT CHANGEVER
- HEAVY DUTY STEEL FRAME WITH POLYETHYLENE RUST & DENT PROOF COVER



*Complete selection of control stations
& accessories are available.*



Power Door Products

(914) 698-5083

www.PowerDoorProducts.com

SERVICING THE INDUSTRY SINCE 1969

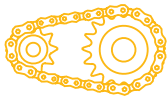

SPECIFICATIONS & FEATURES

AVAILABLE HORSE POWER: 1/2 HP - 2 HP

POWER REQUIREMENTS: 115/230V, 1 PHASE;
OR 230/460V, 3 PHASE

CLASS II LOW VOLTAGE CONTROL CIRCUIT

GATE CAPACITY: 1500 LBS, 50 FT WIDE, UP TO
30 CYCLES PER HOUR

TRAVEL SPEED: 9 INCHES PER SECOND

HEAVY DUTY #11 GA. STEEL FRAME

HARD SHELL, BAKED ON, WEATHER RESISTANT
POWDER COATING

40:1 GEAR REDUCER IN OIL BATH ASSURES
SMOOTH AND QUIET OPERATION

POST OR PAD-MOUNTABLE

PADLOCKABLE DRIVE DISCONNECT WITH BRASS
SLIDE FOR MANUAL OPERATION IN CASE OF
POWER FAILURE

UL 325 LISTED FOR USE IN CLASS I THROUGH IV
APPLICATIONS

SHIPPING WEIGHT: APPROX. 235 LBS

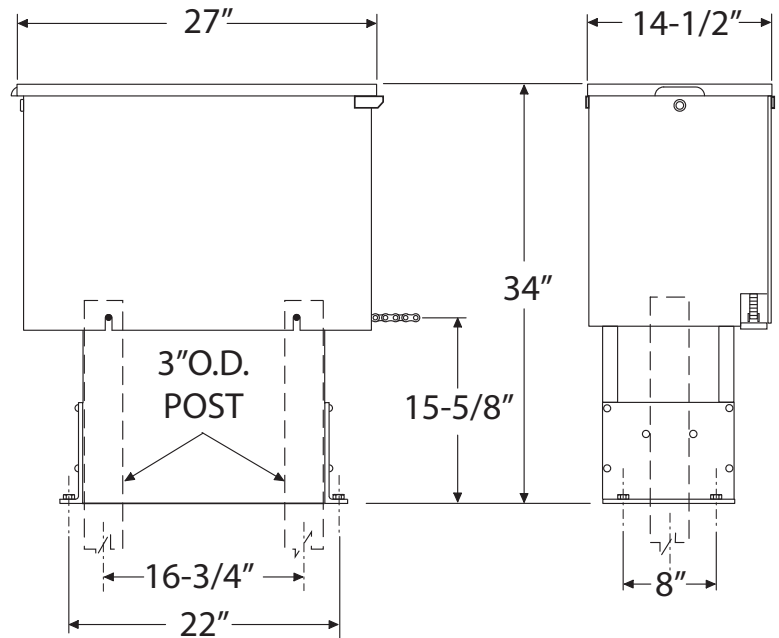

OPTIONAL EQUIPMENT

- ADDITIONAL SAFETY EDGE (CONTACT SAFETY SENSOR)
- ADDITIONAL PHOTO CELL (NON-CONTACT SAFETY SENSOR)
- PLUG-IN LOOP DETECTORS
- WARNING EQUIPMENT (HORNS, LIGHTS)
- GEAR BOX HEATER FOR COLD CLIMATES
- THERMOSTATICALLY CONTROLLED COOLING FAN FOR HOT CLIMATES
- TORQUE LIMITING CLUTCH
- STEEL COVER IN LIEU OF POLYETHYLENE COVER

CAUTION

A moving gate can cause serious injury or death! Carefully read and follow all safety instructions, precautions, and guidelines when installing and using this product. Motorized gates are for vehicles only. Pedestrians must use a separate entrance. NO ONE SHOULD CROSS THE PATH OF A MOVING GATE! Proper reversing devices must be installed on gates to avoid all hazards, pinch points and entrapment. Eliminate all hazards, pinch points and entrapment areas. Warning signs must be permanently installed and visible to traffic and pedestrians. Do not mount operating devices accessible through gates or between a gate and wall. Never allow children to lay in the path of a gate. Never allow children to operate or play with the gate controls. Follow UL 325 and ASTM F220-02 standards. Do not install this product unless all hazards, pinch points and entrapment points are protected.

