

# powermaster

## J

**Door Operator for Sectional Doors with Standard Lift, High Lift, or Vertical Lift, as well as Rolling Service Doors and Grilles**

### **STANDARD FEATURES**

- HIGH STARTING TORQUE MOTOR WITH FULL OVERLOAD PROTECTION
- ON BOARD OPEN/CLOSE/STOP BUTTONS FOR SERVICE AND ADJUSTMENTS
- SOLID STATE CIRCUITRY WITH FEEDBACK LED'S
- FIELD ADJUSTABLE BUILT-IN FUNCTIONS
- AUTO DETECT MONITORED PHOTO BEAM FOR SIMPLIFIED INSTALLATION
- FLOOR LEVEL DISCONNECT FOR MANUAL OPERATION
- HEAVY DUTY V-BELT AND CHAIN REDUCTION, MECHANICALLY SELF LOCKING



*Complete selection of control stations  
& accessories are available.*

**All door operators are required to have a monitored safety system, such as monitored photo eyes and/or monitored 2 or 4 wire obstruction sensing edge. In addition, an ancillary device may be used. The primary device must be a constantly monitored, anti entrapment/safety device.**



Power Door Products

(914) 698-5083

[www.PowerDoorProducts.com](http://www.PowerDoorProducts.com)

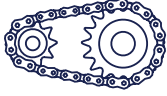

## SPECIFICATIONS & FEATURES

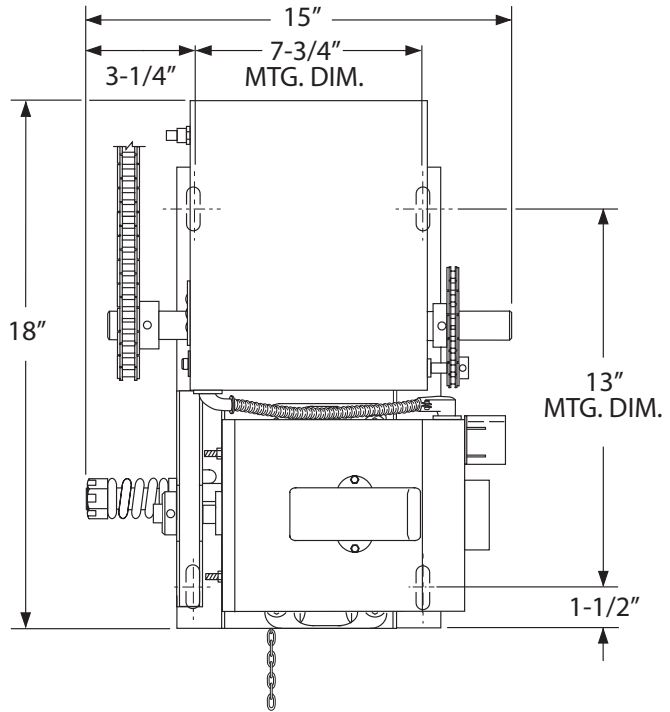
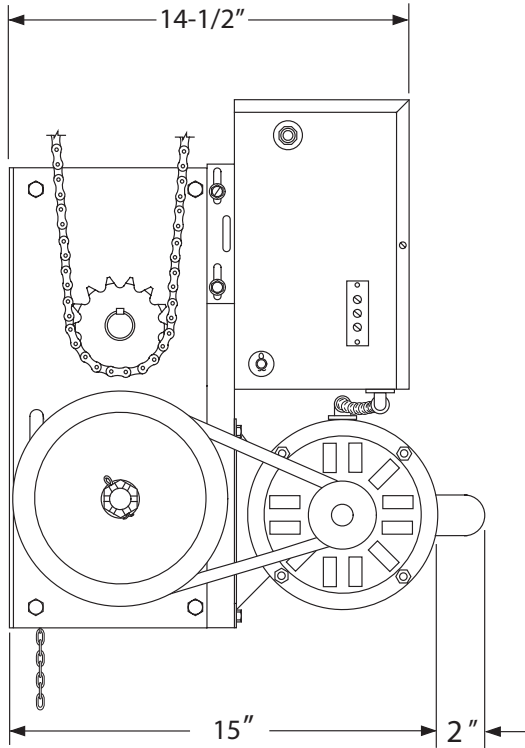

**AVAILABLE HORSE POWER:** 1/2 HP - 1 HP

**POWER REQUIREMENTS:** 115/230V 1Ø OR 208/230/460V 3Ø

SELECTABLE OPERATING MODES B2, C2, D1, E2, T, TS

FIELD ADJUSTABLE BUILT IN FUNCTIONS INCLUDING: TIMER TO CLOSE, MID-STOP, DELAY ON REVERSE, LOCK BAR SENSING, MAXIMUM RUN TIME, ETC.

HEAVY DUTY #50 ROLLER CHAIN AND DRIVE SPROCKET INCLUDED

ADJUSTABLE TORQUE LIMITING CLUTCH

BAKED ON, BLACK POWDER COAT FINISH

**SHIPPING WEIGHT:** APPROX. 85 LBS

## CAUTION

A moving door can cause serious injury or death! Carefully read and follow all safety instructions, precautions, and guidelines when installing and using this product. Motorized doors are for vehicles only. Pedestrians must use a separate entrance. **NO ONE SHOULD CROSS THE PATH OF A MOVING DOOR!** Proper reversing devices must be installed to avoid all hazards and entrapment. Eliminate all hazards and entrapment areas. Warning signs must be permanently installed and visible to traffic and pedestrians. Never allow children to operate or play with controls. Follow UL 325 and ASTM F220-02 standards. Do not install this product unless all hazards and entrapment points are protected.

