

LUMUX

POST TOP PT530SC

The Lumux Post Top ("PT") series is a family of precision engineered, energy efficient LED architectural post tops that are designed for durability and performance. Constructed from the highest quality materials and components, the PT series is a powerful solution to illuminate large areas such as parking lots, public spaces, common areas, parks, entrance ways, in addition to many others. The Lumux PT housing features low-copper, corrosion resistant, die cast aluminum that is designed for long-lasting applications in severe weather conditions. All hardware is vandal resistant, stainless-steel while also featuring closed cell, silicon foam gasketing that seals out moisture, dust, and insects for weather-tight operation. All Lumux PT luminaires are dark-sky friendly, as all models offer a shielded light source with either a visor or a hood, while a glass diffuser reduces glare and enhances visual comfort. The PT series offers a range of design options that are suitable for both modern and classic architecture and a variety of mounting and installation options are available such as pole mounting, wall mounting, or pendant mounting.

Housing: Heavy-duty construction of corrosion resistant, low-copper die cast aluminum. All hardware is vandal resistant, grade 316 stainless-steel.

Lens: 1/8" thick shatter proof clear glass diffuser

Mounting: Pole mount, wall mount, or pendant; multiple configurations available (please refer to diagram)

Installation: Wall mount bracket is 6.25" in diameter; post top tenon is 3.0" in diameter by 3.5" in length

Finish: Zinc polyester powder coat finish in black, white, silver, bronze, or any custom RAL color. Consult factory for marine grade or anti-microbial finish.

Driver: Constant current and universal input voltage 120/277V, starting temperature rated at -20°F. Dimmable option available (0-10v).

Gasket: Closed cell silicon foam gasket that seals out moisture, dust, and insects for weather tight operation.

Protection Class: IP65, ETL Listed for wet locations

Wattage: 47.6W

Color Temperature: 2700K / 3000K / 3500K / 4000K

Delivered Lumens: 2700K 3000K 3500K 4000K
1090Lm 1215Lm 1280Lm 1347Lm

Please consult factory for higher lumen packages

CRI: 90

Warranty: 5 year limited warranty

DATE: _____
PROJECT: _____
FIRM: _____
CATALOG NO.: _____
COMMENTS: _____



Dimensions:

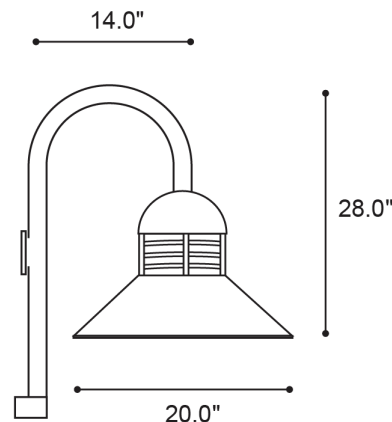

LUMUX

POST TOP PT530SC

DATE:

PROJECT:

FIRM:

CATALOG NO.:

COMMENTS:

Ordering Guide:

Catalog No.	LED Color	Color Temp ¹	Voltage	Finish	Options ²
PT530SC	White	2700K	120/277	Black	<input type="checkbox"/> Dimmable driver (0-10v) <input type="checkbox"/> Post Top - 1 Head <input type="checkbox"/> Post Top - 2 Heads <input type="checkbox"/> Post Top - 3 Heads <input type="checkbox"/> Wall Mount <input type="checkbox"/> Pendant <input type="checkbox"/> Photocell
		3000K		White	
		3500K		Silver	
		4000K		Bronze	
				Custom RAL ²	

¹Consult factory for additional options

²Consult factory for pricing

²Consult factory for pole lengths

Catalog No.: _____