

QUARRY MINING

& CONSTRUCTION EQUIPMENT PTY LTD

EXPERTISE

QUALITY

INNOVATION

GROUT MIXERS AND PUMPS

- ✓ Versatile and easy to use
- ✓ Mesh guards fitted

OPTIONS:

- ✓ 150 and 500 litre capacities
- ✓ Thixotropic bowl or flat bottom
- ✓ Standard or high torque mixer
- ✓ Standard or high flow pumps



WWW.QUARRYMINING.COM

EXPERTISE YOU CAN DEPEND ON

NSW: 9/14 Yangan Drive, Beresfield NSW 2322 ph: +61 (0)2 4966 5028 fax: +61 (0)2 4910 9022 e: orders@quarrymining.com
QLD: 5/35 Iridium Drive, Paget QLD 4740 ph: +61 (0)7 4998 5295 fax: +61 (0)7 4805 6126 e: ordersqld@quarrymining.com

M150 & M150EQ Grout pump performance at 689 kPa air pressure, pumping water.
 M150P Grout pump performance at 600kPa air pressure pumping water.

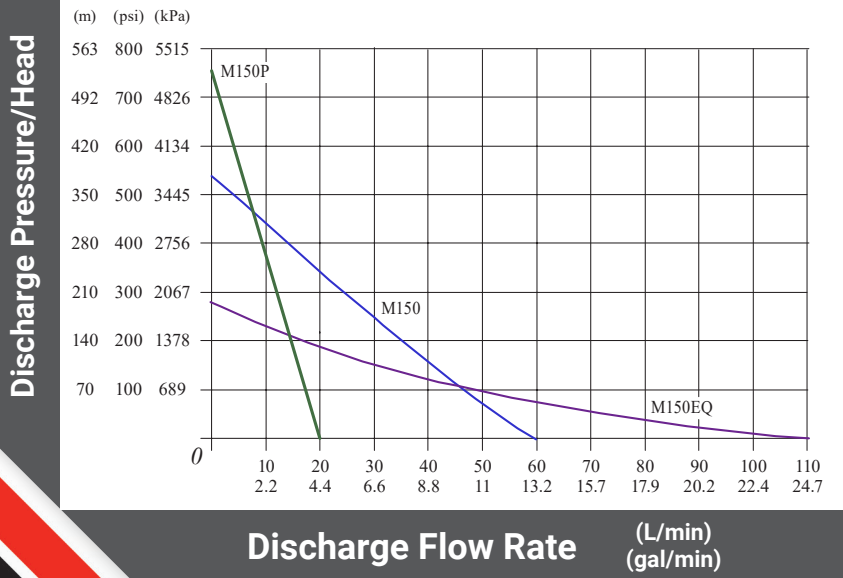

SPECIFICATIONS	M150P	M150	M150EQ
Motor Piston (Ømm)	150	150	150
Weight (kg)	16.6	17	19
Length (mm)	1056	1090	1095
Maximum Flow (L/min)	20	60	110
Maximum Pressure (kPa)	5100	3500	1900
Maximum Air Supply (m³/h)	50	50	50
Discharge Port (mm BSP)	25	25	40

Power curve 08TD1000M air motor

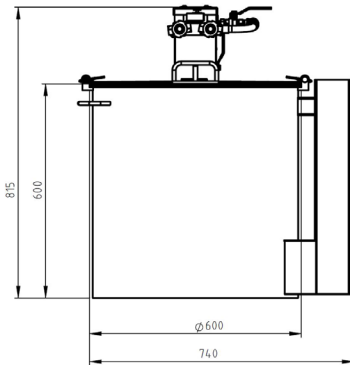
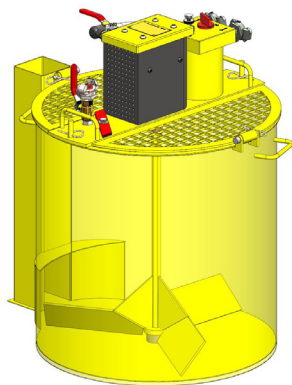
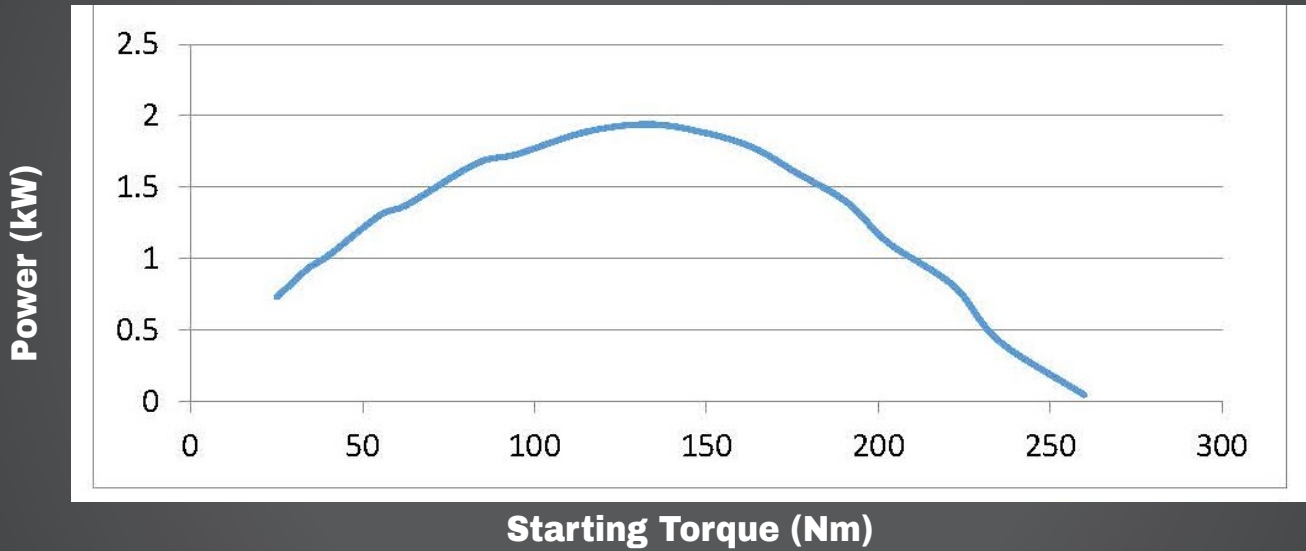

GP407 GROUT MIXER

- Power: 1.94 kW @ 133 rpm
- Maximum free speed: 260 rpm
- Starting torque: 279 Nm
- Stall torque: 501 Nm
- Air Consumption: 37 L/sec
- Weight: 49 kg