

Electric  
AVENUE

 **Yatti**  
— PRO LITE

48A LEVEL 2 EV CHARGER  
INSTALLATION & USER GUIDE



### Proper Disposal:

Electric Avenue's Watti Pro Lite EV charger is electronic and therefore may not be disposed of as part of unsorted domestic waste. Inquire with local authorities regarding proper disposal. Product materials are recyclable as marked.

### Legal:

Any information in this manual may be changed without prior notice and does not represent any obligation on the part of the manufacturer. Any resulting damage due to disregard or actions contrary to the instructions in this manual is excluded from the product warranty. Images in this manual are for illustration purposes only and may differ from the delivered product.

© 2023 Electric Avenue Manufacturing Inc. All rights reserved. This document is protected by the copyright laws of Canada, the United States and other countries. Modification, reproduction and/or distribution of this material is strictly prohibited without prior written permission of Electric Avenue.

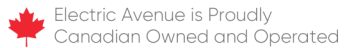

## TABLE OF CONTENTS

Important Safety Information.....	2
Charger Specifications.....	5
Getting Started	
Charger Interface.....	6
Package Contents.....	8
Tools Required for Installation.....	9
Setting the Desired Output Current.....	10
Installation	
Mounting the Charger.....	11
Hardwire Installation.....	13
Connect to a Network (LAN).....	15
Connect to a Network (WiFi).....	17
Connect to Central System.....	18
Operating the Charger	
Choosing the Charge Mode.....	19
Operating as Plug and Charge.....	20
Operating with the Mobile App.....	22
Download the Mobile App.....	22
Operating with the Mobile App.....	23
Operating with RFID.....	24
RFID Setup.....	24
Operating with RFID.....	25
LED Indicator Light Meanings.....	26
Error & Warning Messages.....	27
Troubleshooting Tips.....	28
Charger Management Backend.....	29
Configuring Device Settings.....	30
Configuring Maintain Settings.....	32
Configuring Operate Settings.....	33
Changing Account Settings.....	33
Warranty.....	34



## IMPORTANT SAFETY INFORMATION

**WARNING:** This manual contains important instructions for installing and using the Watti Pro Lite EV charger. When using electrical products, always follow basic precautions, including the following.

**Read and follow all safety warnings and instructions before installing and operating the Watti Pro Lite EV charger.**

Install and operate only as instructed. Failure to do so may lead to property damage, injury or death and will void the standard warranty.

**Only allow licensed professionals to install, adjust or service the Watti Pro Lite EV charger and adhere to all national and local building codes and standards.**

Before installing or servicing the Watti Pro Lite EV charger, consult with a licensed contractor, such as a licensed electrician, and allow a trained installation expert to ensure compliance with local building and electrical codes/standards, climate conditions, safety standards, and all applicable codes and ordinances. Inspect the charging station for proper installation prior to use.

**IMPORTANT:** Under no circumstances will compliance with the information in this manual relieve the user of their responsibility to comply with all applicable codes or safety standards. This document describes the most commonly used installation scenarios. If situations arise in which it is not possible to perform an installation following the procedures provided in this document, contact Electric Avenue.

**Electric Avenue is not responsible for any damages that may occur resulting from custom installations that are not described in this document or for any failure to adhere to installation recommendations.**



## IMPORTANT SAFETY INFORMATION

### **WARNING:**

- DO NOT put fingers into the EV connector.
- DO NOT touch the charging connector terminal with any sharp metallic objects, in order to prevent damage.
- DO NOT use this product if the power cord or EV cable is frayed, has broken insulation, or shows any other indication of damage.
- DO NOT use this product if the enclosure or the EV connector is broken, cracked, open, or shows any other indication of damage.
- DO NOT attempt to remove, open, disassemble, repair, tamper with, or modify the charger.
- DO NOT use this product with an extension cord.
- DO NOT put heavy objects on the charger.

**WARNING:** This device must be grounded. Failure to ground the charging station can lead to risk of electrocution or fire. The charging station must be connected to a grounded, metal, permanent wiring system. Equivalently, an equipment grounding conductor shall be run with circuit conductors and connected to the equipment grounding terminal or grounding lead on the EV charger.

**WARNING:** This device should be supervised when used around children.

**WARNING:** To reduce the risk of fire, connect only to a branch circuit over-current protection device in accordance with the CSA C22.1-15 Canadian Electrical Code, Part 1 (Canada) or ANSI / NFPA 70 National Electrical Code (USA).

**WARNING:** Disconnect electrical power prior to installing the charging station.

**WARNING:** Risk of explosion. This device has arcing or sparking parts that should not be exposed to flammable vapors and is not suitable for use in hazardous locations. Do not install or use the charger near flammable, explosive, corrosive, or combustible materials, chemicals, or vapors.



## IMPORTANT SAFETY INFORMATION

**CAUTION:** Use appropriate protection when connecting to the main power distribution cable.

**CAUTION:** Type B, C or D breakers with the appropriate current rating should be installed in the upstream AC distribution box.

Circuit Breaker Options				
Output Amperage	16A	32A	40A	48A
Circuit Breaker Options	20A	40A	50A	60A

**CAUTION:** The device shall be mounted at a height between 60 cm (2 ft) and 120 cm (4 ft) from the ground.

**CAUTION:** Do not operate in conditions outside its operating range. The range of use for the Watti Pro Lite EV charger is a maximum 95% relative humidity and between  $-40^{\circ}\text{C}$  to  $50^{\circ}\text{C}$  ( $-40^{\circ}\text{F}$  to  $122^{\circ}\text{F}$ ).

**CAUTION:** Avoid moisture or water in the charger. If there is water or moisture in the charger, immediately power off and notify a professional to carry out maintenance before next use.

**CAUTION:** Other than the charging cable, the Watti Pro Lite EV charger contains no field serviceable parts. Do not attempt to repair or service any other part of the charger. If the charger requires servicing, please contact Electric Avenue support.

**CAUTION:** Always ensure that the charging cable is positioned so it is not stepped on, tripped over, or subjected to damage or stress.

### NEED ASSISTANCE?



Electric Avenue Technical Support:  
1-888-353-2283  
[support@goelectricave.com](mailto:support@goelectricave.com)

## CHARGER SPECIFICATIONS

Model Numbers	EAWPLT48-18WI1HWBL, EAWPLT48-18WI1HWWH, EAWPLT48-25WI1HWBL, EAWPLT48-25WI1HWWH
Rated Input Voltage	200-240 VAC
Rated Output Voltage	16/32/40/48A
AC Power Frequency	60 Hz
Input Protection	UVP, OVP, RCD (CCID20), SPD, Ground Fault Protection
Output Protection	OCP, OTP, Control Pilot Fault Protection
Output Interface	SAE J1772 AC Charging Connector
Operation Temperature	-40°C to 50°C (-40°F to 122°F)
Storage Temperature	-40°C to 70°C (-40°F to 158°F)
Relative Operation Humidity	Up to 95% non-condensing
Relative Storage Humidity	Up to 95% non-condensing
Network Connection	LAN Version / WiFi Version
Internet Function	10M / 100M Base-T
WiFi Function	802.11 b/g/n
Cable Length	5.5m (18ft) / 7.6m (25ft)
Protection Level	NEMA 4X / IP65
Installation Type	Wall-Mounted/ Pedestal-Mounted
Altitude	≤ 6561ft
Status Indication	Red, Green, Blue LED

## GETTING STARTED

### CHARGER INTERFACE



**CAUTION:** Avoid placing the charger near hot objects or in high temperature locations. Place the charger away from dangerous substances such as flammable gases and corrosive materials.

---

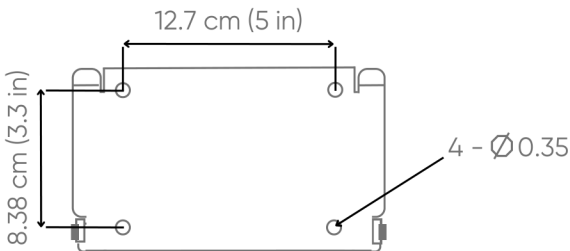
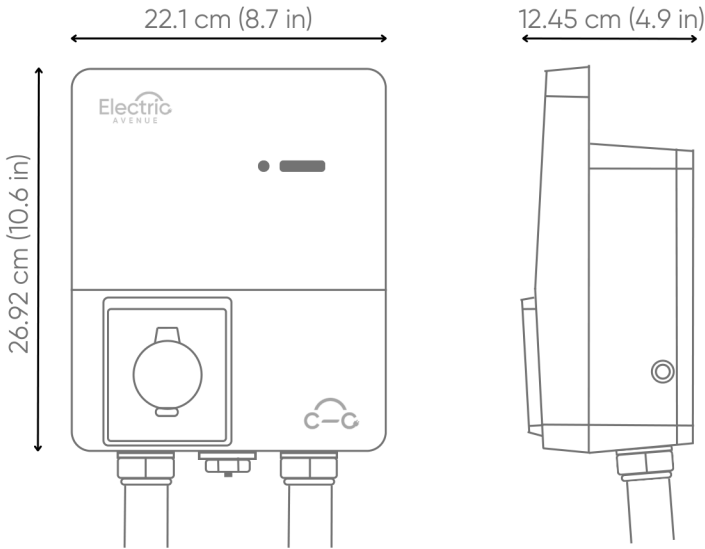



## GETTING STARTED

### CHARGER INTERFACE



**CAUTION:** Avoid placing the charger near hot objects or in high temperature locations. Place the charger away from dangerous substances such as flammable gases and corrosive materials.

Front

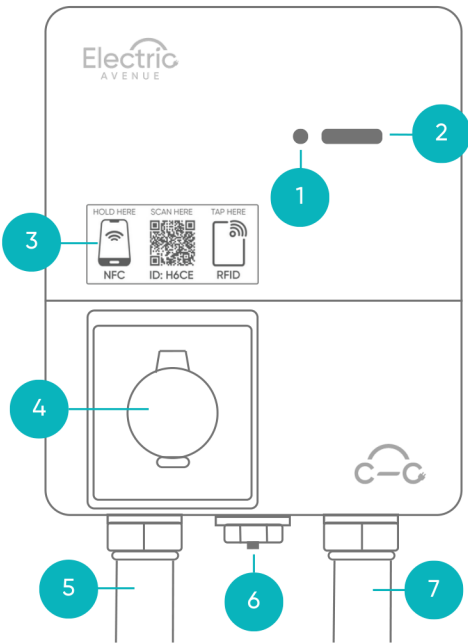

Back

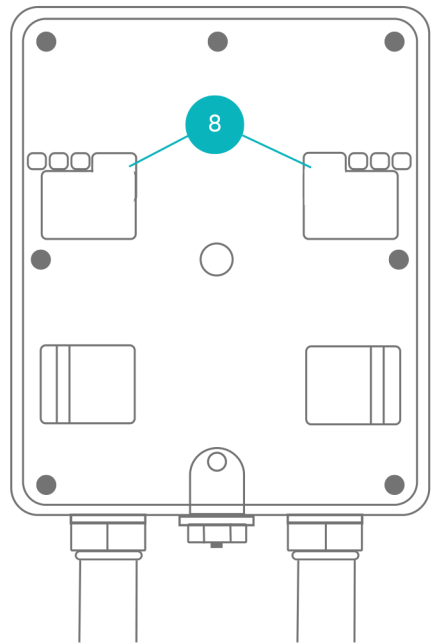

#### Charger Interface Components:

- |                                |                                       |
|--------------------------------|---------------------------------------|
| 1. LED network indicator light | 5. AC power cable                     |
| 2. LED status indicator light  | 6. Exterior ethernet (LAN) cable port |
| 3. NFC, QR code & RFID sensor  | 7. Charging cable                     |
| 4. Charging connector holster  | 8. Rear notches                       |

## GETTING STARTED

### PACKAGE CONTENTS

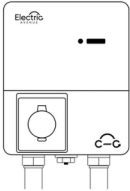

(1) Watti Pro Lite EV charger



(1) Installation and user guide

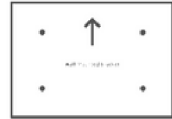

(1) Quick Start Guide with WALL BRACKET MOUNTING TEMPLATE



(1) Mounting bracket



(4) M6 hexagonal expansion screws



(4) Screws and drywall anchors



(2) M5 anti-theft round head screws



(1) Allen wrench



(1) Black flex conduit



(1) Hardwired ethernet Kit

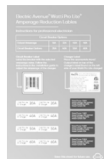

(1) Amperage reduction label sheet



(2) RFID cards

## GETTING STARTED

### TOOLS REQUIRED FOR INSTALLATION

Gather the following tools before beginning to install the Watti Pro Lite charger:

1. Wire stripper
2. Socket wrench
3. Voltmeter or digital multi-meter
4. Level
5. Pencil or marker
6. Drill and drill bit
7. Phillips screwdriver
8. Stud finder (optional)

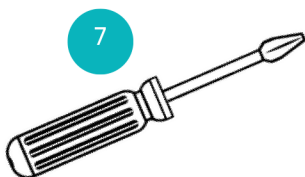
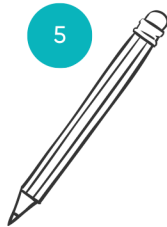
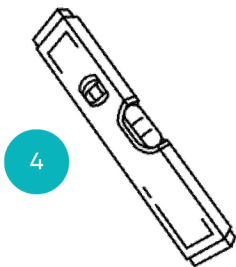
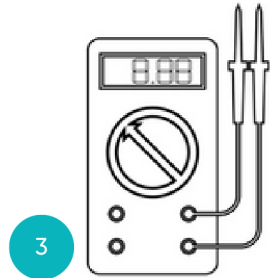
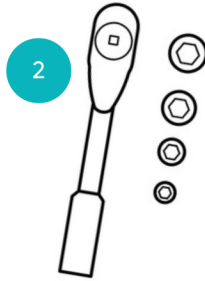

## GETTING STARTED

### SETTING THE DESIRED OUTPUT CURRENT

The Watti Pro Lite EV charger can support different maximum output currents by adjusting the rotary switch behind the front cover.

#### STEP 1

Determine the desired charging amperage with the owner. Set the amperage based on the electrical capacity and availability of space in the panel.

#### STEP 2

Access the rotary switch by removing the (7) screws on the back of the charger and removing the front cover.

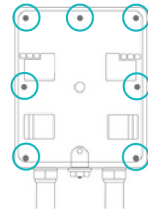

#### STEP 3

Use a non-conductive object to adjust the switch. Set the switch setting number based on the maximum output current in the table below.

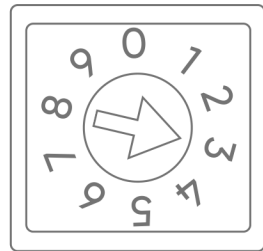

Rotary Switch Settings				
Switch Setting Number	0	1	2	3
Maximum Output Current	16A	32A	40A	48A

#### STEP 4

Reattach the cover using the (7) screws, ensuring they are secure.

## INSTALLATION

### MOUNTING THE CHARGER



**WARNING:** In areas with frequent thunderstorms, add surge protection at the service panel for all circuits. Ensure all power and ground connections, especially those at the breaker and bus bar, are clean and tight.



**CAUTION:** Not recommended to be installed in coastal environments with high humidity or high dust.

#### STEP 1

Select an appropriate mounting location with electrical capacity.

Ensure the owner has chosen a mounting location that allows the charging cable to reach the car's charging port while still providing slack.

The device must be anchored into 2" x 4" studs, a solid wall of concrete or brick or a properly reinforced drywall surface using drywall anchors (supplied).

The device shall be mounted at a height between 2 feet (60 cm) and 4 feet (120 cm) from the ground.

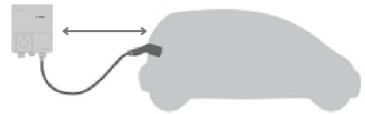

Note: Outdoor installation requires an outdoor-rated, weather-resistant electrical outlet or hardwired installation.

#### STEP 2

Place the mounting template over the selected location. Ensure the template is level before drilling holes for the mounting screws.

Pre-drill the four mounting holes.

Remove the mounting bracket template.



## INSTALLATION

### MOUNTING THE CHARGER

#### STEP 3

Place the mounting bracket on the wall, aligning the screw holes with the pre-drilled holes.

If mounting to brick or concrete, use the (4) hexagonal expansion screws to secure the wall-mounted bracket to the wall.

If mounting to drywall, use the (4) anchors and (4) drywall screws to secure the bracket to the wall and studs.

Ensure the bracket is level before tightening.

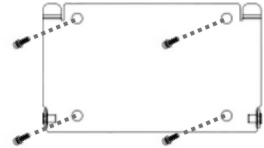

#### STEP 4

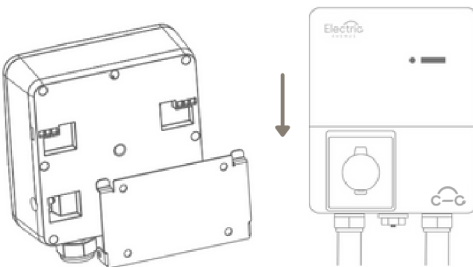

Align the rear notches of the charger with the wall-mounted bracket, and guide the charger over the notches. Gently press and slide the charger downward to secure the charger into the bracket.

Ensure the screw holes on the right and left side of the charger align with the screw holes on the left and right side of the mounting bracket.

#### STEP 5

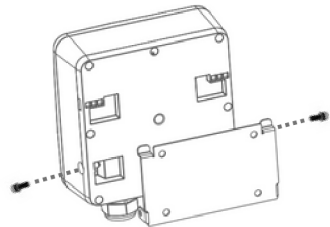

Insert and tighten the M5 anti-theft screws on either side of the charger to secure it in place. Installation is complete.

## INSTALLATION

### HARDWIRE INSTALLATION



**RISK OF SHOCK:** Switch the circuit breaker OFF. Do not restore power until installation is complete. Failure to follow these instructions could result in shock or electrocution.



**WARNING:** This device must be grounded. Disconnect electrical power prior to installing the charging station.



**WARNING:** Improper connection of the equipment-grounding conductor would result in a risk of electric shock. Check with a qualified electrician or serviceman if you are not sure whether the product is properly grounded. Do not modify the plug provided with the product – if it doesn't fit the outlet, have a proper outlet installed by a qualified electrician.



**CAUTION:** Use appropriate protection when connecting to the main power distribution cable.



**CAUTION:** Ensure that the wire type, diameter, current rating, and temperature rating comply with the local electrical standards and requirements in your local area.

### STEP 1

For safe use of electricity, install the appropriate circuit breaker protection on the input power side of the charger. The circuit breaker must be switched to the OFF position before wiring the charger. See page 4 for breaker sizes.

### STEP 2

Install the appropriate electrical conduit or armoured cable from the electrical supply panel to a junction box or disconnect. Place the junction box or disconnect within 20 inches of the bottom left-hand corner of the charger.

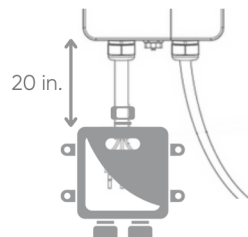

# INSTALLATION

## HARDWARE INSTALLATION

### STEP 3

Hardwire the charger leads to the electrical supply panel. To complete the wiring, make the following connections:

- Connect the L1 lead to the grid L1
- Connect the L2 lead to the grid L2
- Connect the PE lead to the grid PE

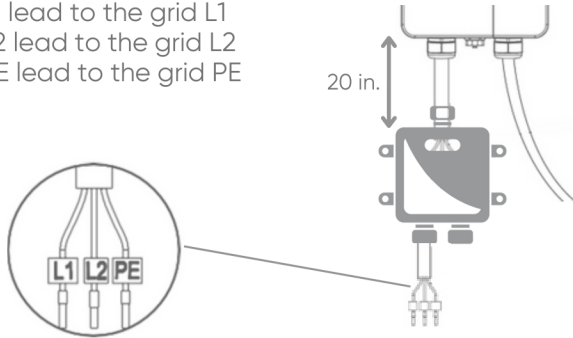

### STEP 4

Affix the supplied amperage label with the appropriate rating to the circuit in the panel, and the corresponding label on the charger's product label, as indicated.

Electric Avenue® Watti Pro Lite®  
Amperage Reduction Labels

Instructions for professional electrician

Output Amperage	10A	20A	40A	60A
Circuit Breaker Options	20A	40A	50A	60A

**Circuit Breaker Label:** Label the breaker with the selected amperage value. Follow the instructions in the installation guide to install with amperage of the charger.

**Charger Label:** Place this representative label/ sticker that replicates the charger's label (found on the left side of your device) into the slot.

Save this sheet for future use.

Example for 20A Breaker

Rated Voltage: 200-240VAC  
Power Frequency: 60Hz  
Rated Current: 16A

Charger Label

Electric Avenue® Electric Vehicle AC Charging Station  
Model No: EA-WPL148-18W1H-WBL  
Electric Avenue Manufacturing Inc.

Conforms to: CSA Std. C22.2#280  
Conforms to: UL Std. 2594  
For use with electric vehicles where ventilation not required.

S/N: EA-WPL02310001  
Protection Level: NEMA 4X/IP55  
Temp. Rating: -30°C to 50°C

Rated Voltage: 200-240VAC  
Power Frequency: 60Hz  
Rated Current: 40A

1-888-353-2283  
GoElectricAve.com  
support@goelectricave.com

20A Breaker Label

Watti Pro Lite EV Charger 20A

Breaker Panel

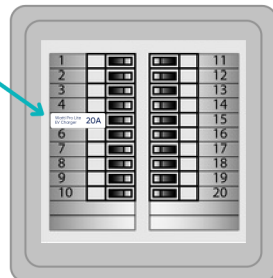



## INSTALLATION

### CONNECT TO NETWORK (LAN)



**RISK OF SHOCK:** Switch the circuit breaker OFF. Do not restore power until installation is complete. Failure to follow these instructions could result in shock or electrocution.



Follow these steps if the charger will be permanently connected to a network port

#### STEP 1

Access the charger's ethernet (LAN) port by removing the (7) screws on the back of the charger and removing the front cover.

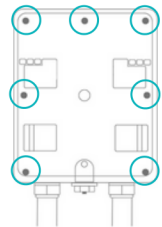

#### STEP 2

Take the ethernet (LAN) cable provided in the Hardwired Ethernet Kit and insert one end into the RJ45 port, found on the right side of the green board located at the top of the front cover.



#### STEP 3

Insert the other end of the ethernet (LAN) cable into the RJ45 port located at the bottom of the back inside of the charger.



#### STEP 4

Feed the external ethernet cable, that will be used for permanent network the charger, through the supplied 1/2 inch grommet.



## INSTALLATION

### CONNECT TO NETWORK (LAN)



**RISK OF SHOCK:** Switch the circuit breaker OFF. Do not restore power until installation is complete. Failure to follow these instructions could result in shock or electrocution.



Follow these steps if the charger will be permanently connected to a network port

#### STEP 5

Field terminate a RJ45 connector (not supplied) to the end of the ethernet cable.

RJ45 Pinout T-568A

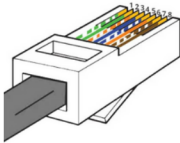

12345678



1. White Green
2. Green
3. White Orange
4. Blue
5. White Blue
6. Orange
7. White Brown
8. Brown



#### STEP 6

Connect the end of the this ethernet cable to the exterior RJ45 port at the bottom of the charger and screw the grommet around the ethernet cord until it's firmly secured. Finish the connection to the network port by neatly running the exterior ethernet cord back to your network port.

#### NEED ASSISTANCE?



Electric Avenue Technical Support:  
1-888-353-2283  
[support@goelectricave.com](mailto:support@goelectricave.com)

# INSTALLATION

## CONNECT TO NETWORK (WIFI)



Follow these steps if the charger will be permanently connected to a WiFi network

### STEP 1

Connect to the charger's WiFi access point. Open the WiFi settings on a laptop or handheld device and locate the 'EA-WPL-XXXXXXXX' network and press 'Connect'.

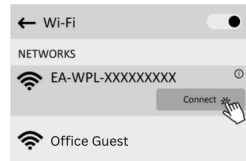

The network name includes the last 9-digits of the serial number, which can be found on the label on the left side of the charger. For example, EAWPL012310001.

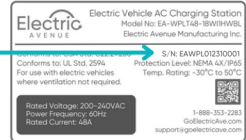

### STEP 2

In the address bar of your browser, type the following IP Address: **192.168.1.1**

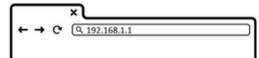

### STEP 3

Log into Electric Avenue's Charger Management Backend using the following credentials:

**Username: admin**  
**Password: admin**

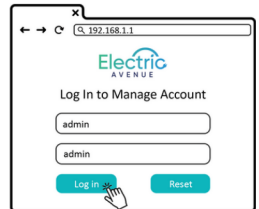

### STEP 4

Locate the WiFi block, then choose the desired WiFi network from the SSID dropdown list. Input the WiFi network password and press 'Submit'. Press 'OK' in the resulting pop-up window.



## INSTALLATION

### CONNECT TO NETWORK (WIFI)

#### STEP 5

The network indicator light will begin to flash blue. This signals that the charger is in the process of establishing connection to the WiFi network.



#### STEP 6

Then, the network indicator light will begin to flash green (may take up to 2 minutes). This signals that the charger has successfully established connection to the WiFi network.



### CONNECT TO A CENTRAL SYSTEM

If the charger is linked to an Enterprise Software subscription, the indicator light will change to quick blinking green, signaling connecting to a central system. Then it will change to solid green, signaling a successful connection to the Electric Avenue central system.

To purchase an Enterprise Software subscription and access smart charging features, visit [GoElectricAve.com](https://GoElectricAve.com) or scan the QR code with the camera on your mobile device.



Scan to shop Enterprise Software Packages:



## OPERATING THE CHARGER

### CHOOSING THE CHARGE MODE

The Watti Pro Lite EV charger can support three different modes of charging: Plug and Charge, Local RFID List, and OCPP. For instructions on how to modify the charge mode, see page 29.

#### PLUG AND CHARGE



Plug and charge mode is an offline mode of charging. Simply put, the user plugs in their EV, and the charger delivers power.

- No software required
- No network connection required
- No user authentication required to charge
- Cannot apply charging tariffs (fees)

#### LOCAL RFID LIST



Local RFID List is also an offline mode of charging. In this mode, RFID cards are used to authenticate (start) a charging session.

- No software required
- No network connection required
- Cannot apply charging tariffs (fees)

RFID cards are programmed directly into the charger (via the Charger Management Backend) and are given to the appropriate user.

#### OCPP (most common mode)



OCPP is a smart charging mode with enhanced features that include remote monitoring, revenue generation, user management and access control, energy reporting, and dynamic load management and more. A stable network connection is required. The Electric Avenue app allows drivers to create accounts, add payment methods, locate available chargers, and start charging. A software subscription is required per char.

## OPERATING THE CHARGER

### OPERATING AS PLUG AND CHARGE



**WARNING:** Do not use this product if the power cord or EV cable is frayed, has broken insulation, or shows any other indication of damage. Do not use this product if the enclosure or the EV connector is broken, cracked, open, or shows any other indication of damage.



**WARNING:** This device should be supervised when used around children.



**CAUTION:** Please use the charger properly. Do not hit or press hard on the enclosure. If the case is damaged, please contact a professional technician



**CAUTION:** Do not put heavy objects on the charger.



**CAUTION:** Do not forcefully pull the charging cable, damage it with sharp objects, or place fingers or insert foreign objects into any part of the charging connector.



**CAUTION:** This charger is designed only for vehicles that are compatible with the SAE J1772 Level 2 charging standard.

Plug and Charge does not require the use of a credit card, RFID tag, or mobile app to initiate a charging session.

If user authentication or payment collection is necessary, an Electric Avenue Enterprise Software subscription is required.

To purchase an Enterprise Software subscription and access smart charging features, visit [GoElectricAve.com](https://GoElectricAve.com) or scan the QR code with the camera on your mobile device.



Scan to shop Enterprise Software Packages:



## OPERATING THE CHARGER

### OPERATING AS PLUG AND CHARGE

#### STEP 1

##### Standby Mode:

After being powered on, during boot up, the charger will flow through a series of network indicator lights and status indicator lights before remaining constantly blue to indicate the charger is in standby mode and ready to use.

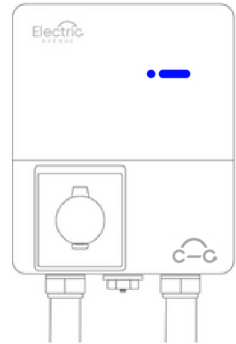

#### STEP 2

##### Connect Your Vehicle:

Plug the charging connector into your EV.

#### STEP 3

##### Active Charging:

During charging, the status indicator light will blink green (Charging).

*If the light is red (Fault), disconnect and reconnect the charging connector to your vehicle. If the light is still red, refer to the Errors and Warnings section on page 27.*

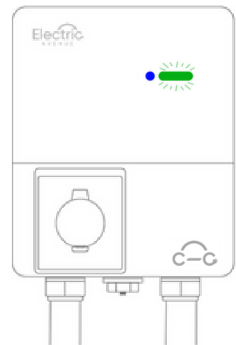

#### STEP 4

##### Charging Complete:

When charging is complete, the status indicator light will display solid green. Press the button on the connector and remove to disconnect the charging connector from your vehicle.

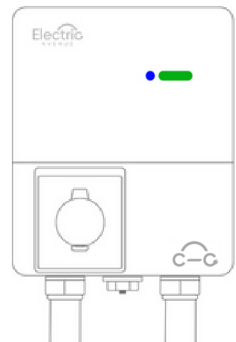

## OPERATING THE CHARGER

### OPERATING WITH THE MOBILE APP

The free Electric Avenue mobile app allows users to find available chargers on the map, add payment methods, and use their account to control start, stop or scheduling charging sessions on any available Electric Avenue commercial charger.



App functionality is only available for chargers that are connected to the Electric Avenue central system and have an Enterprise Software subscription.

To purchase an Enterprise Software subscription, visit [GoElectricAve.com](http://GoElectricAve.com)

## DOWNLOAD THE ELECTRIC AVENUE APP

### STEP 1

Download the Electric Avenue app for iOS or Android.



### STEP 2

Follow the steps to create your user account within the app.

### STEP 3

Add a payment method.

Tap the hamburger menu in the top left corner and tap the green circle beside Pay via: N/A to add a credit card to your account for your payment method.

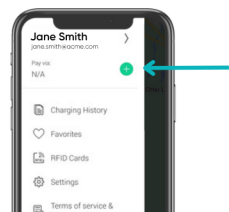



## OPERATING THE CHARGER

### OPERATING WITH THE MOBILE APP



App functionality is only available for chargers that are connected to the Electric Avenue central system and have an Enterprise Software subscription.

#### STEP 1

In the Electric Avenue app, tap the QR code icon in the center of the bottom menu, and scan the QR code sticker found on the front of the charger, or enter the charger's ID # manually (4-digit and/or letter combo).



#### STEP 2

In the Electric Avenue app press 'Start Charging'.

#### STEP 3

Connect your vehicle by plugging the charging connector into your vehicle's charging inlet.

#### STEP 4

The session is already initiated and the vehicle will begin to charge automatically. During charging, the status indicator light (bar) will flash green.

*If the light is red (Fault), disconnect and reconnect the charging connector to your vehicle. If the light is still red, refer to the Errors and Warnings on page 27*



#### STEP 5

When charging is complete, the status indicator light (bar) will display solid green.

Press the button on the connector and remove to disconnect the charging connector from your vehicle.



## OPERATING THE CHARGER

### OPERATING WITH RFID

To associate the included RFID cards to your Electric Avenue account, or to set up additional RFID cards and/or FOBs within the Electric Avenue app, follow the instructions below.



Need more RFID cards? Purchase packages of 10, 25 or 100 RFID cards and keychain FOBs through our website at [goelectricave.com](http://goelectricave.com).

### RFID SETUP

#### STEP 1

Download the Electric Avenue app for iOS or Android (see 'Operating with The Mobile App' section, on page 23) and create your user account, following the steps within the app.

#### STEP 2

Within the Electric Avenue app, tap the hamburger menu in the upper left and select "RFID Cards", and then "Add RFID Tag".

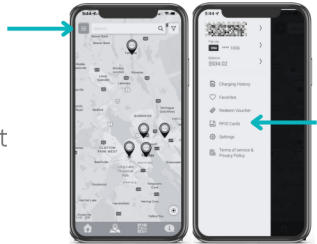

#### STEP 3

Tap "Scan QR Code" and scan the QR code sticker, found on the front of the charger (NOTE: RFID setup can be done on any networked OCPP Electric Avenue charger)

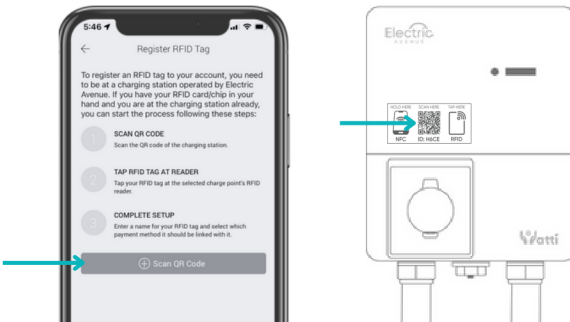

## OPERATING THE CHARGER

### OPERATING WITH RFID

#### RFID SETUP

##### STEP 4

Tap the RFID Card or Tag directly on the RFID card icon on the front of the charger.

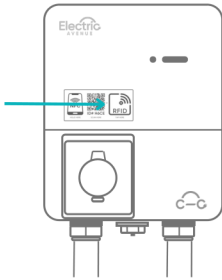

##### STEP 5

In the app you will be prompted to enter a name for your RFID tag and select your payment method from the drop down menu, then tap "Save"



Once an RFID has been added to a user account, the RFID can be used to initiate a charging session on any public charger within our network.

### OPERATING WITH RFID

#### STEP 1

Connect your vehicle by plugging the charging connector into your vehicle's charging inlet.

#### STEP 2

Tap the RFID card or FOB directly on the RFID icon on the front of the charger.

#### STEP 3



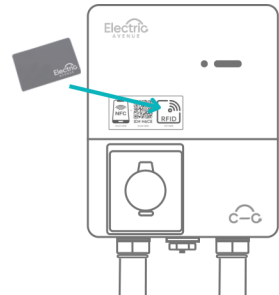

When charging is complete, remove the charging cable and place the connector back in the charger's holster.







## OPERATING THE CHARGER

### LED INDICATOR LIGHT MEANINGS

#### NETWORK INDICATOR LIGHT (CIRCLE)

Offline	Connecting to WiFi	Connected to WiFi	Connected to central system	Connection Failed
				
Solid Blue	Blinking Blue	Blinking Green	Solid Green	Solid Red

#### STATUS INDICATOR LIGHT (BAR)

Standby: Waiting to Plug In	Initiating Charge: Communicating with Vehicle	Charging In Progress	Charging Complete	Fault
				
Solid Blue	Solid Green	Blinking Green	Solid Green	Solid Red

#### NEED ASSISTANCE?



Electric Avenue Technical Support:  
 1-888-353-2283  
[support@goelectricave.com](mailto:support@goelectricave.com)

## OPERATING THE CHARGER

### ERROR AND WARNING MESSAGES

Fault Status	Red
Voltmeter fault	1 flash followed by 3 sec pauses
Control pilot fault	2 flashes followed by 3 sec pauses
Input UVP	3 flashes followed by 3 sec pauses
Input OVP	4 flashes followed by 3 sec pauses
OTP	5 flashes followed by 3 sec pauses
OCP	6 flashes followed by 3 sec pauses
Ground fault	7 flashes followed by 3 sec pauses
Relay fault	8 flashes followed by 3 sec pauses
RCD abnormal	9 flashes followed by 3 sec pauses
RCD self-test fault	10 flashes followed by 3 sec pauses

#### NEED ASSISTANCE?



Electric Avenue Technical Support:  
 1-888-353-2283  
[support@goelectriccave.com](mailto:support@goelectriccave.com)

## OPERATING THE CHARGER

### TROUBLESHOOTING TIPS

#### Network Connection Failed



If the LED network indicator light (circle) is solid red (connection failed notification), it means the network connection to the charger has been lost. Reboot the WiFi access point or network switch. If the error persists, contact your network service provider.

#### Charging Connection Fault



If the LED Status Indicator light (bar) is solid red (fault notification), it means the connection between the charger and vehicle has been lost. Unplug the charging connector from the vehicle and cycle through a power off/power on sequence by switching the circuit breaker OFF and then switching it back ON. If the error persists, contact Electric Avenue Support for additional instructions on how to resolve the error.

#### Charging In Progress



When initiating a charge, if the LED status indicator light (bar) does not transition from solid green (indicating initiating a charge: communicating with the vehicle) to blinking green (indicating charging in progress), unplug the connector from the vehicle and restart the session. If unwarranted tariffs are a result of this failure, please reach out to Electric Avenue for compensation.

#### NEED ASSISTANCE?



Electric Avenue Technical Support:  
1-888-353-2283  
[support@goelectricave.com](mailto:support@goelectricave.com)

## CHARGER MANAGEMENT BACKEND

The Charger Management Backend allows for the adjustment of various charger settings. This section reviews the configuration options and describes them in detail. To log into the Charger Management Backend, follow steps 1-3 on page 17.

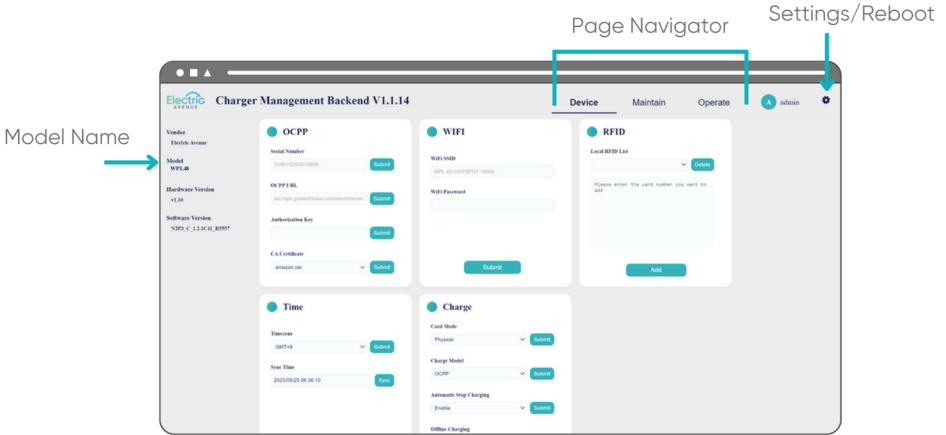

The Charger Management Backend consists of three distinct settings pages: Device, Maintain, and Operate.



### DEVICE

This section allows you to manage and customize the operational settings of the charger itself. You can adjust the parameters within the blocks labeled OCPP, WiFi, RFID, Time, and Charge.

### MAINTAIN

This section provides the option to update the charger's firmware and alternate CA Certificates.

### OPERATE

This section is where the charger can be restored to its original factory settings.

# CHARGER MANAGEMENT BACKEND

## CONFIGURING DEVICE SETTINGS



### OCPP BLOCK

Sub-Setting	Details
Serial Number	Unique identifier assigned to each individual charger. Also used to identify the EVSE on the OCPP central system (sometimes referred to as the Charge Point ID).
OCPP URL	WebSocket used to point the charger to the desired OCPP central system. The connection can be non-secure (ws://) or secure (wss://) depending on the server requirements.
Authorization Key	Used when a secure OCPP URL connection (wss://) is required. Provided by the OCPP central system host.
CA Certificate	Used by the central system to verify the EVSE through the OCPP gateway host. Electric Avenue uses Amazon AWS IoT core. For alternate certificates, visit the "Upload" section under "Maintain".

**OCPP**

**Serial Number**

**OCPP URL**

**Authorization Key**

**CA Certificate**

### RFID BLOCK

Sub-Setting	Details
Local RFID List	Facilitates the direct programming of RFID cards into the charger by utilizing their 6-digit HEX code. This feature enables user access control in the absence of an OCPP connection or software subscription.
Adding RFID Cards	Type the hex code on the back of your Electric Avenue RFID card into the Local RFID List field, and click the 'Add' button.
Delete RFID Cards	Select the card number you wish to delete from the drop-down list and click the 'Delete' button.

**RFID**

**Local RFID List**

Please enter the card number you want to add



# CHARGER MANAGEMENT BACKEND

## CONFIGURING DEVICE SETTINGS



### TIME BLOCK

Sub-Setting	Details
Timezone	Manually set the local time zone
Sync Time	Clicking the 'Sync' button will sync the device to the local time. It is not required when connecting the EVSE to the Electric Avenue OCPP central system. Some alternate OCPP Central Servers may require this to be set.



### CHARGE BLOCK



Once you've entered the preferred settings in the Charge block, click 'Apply Changes' to ensure the modifications are saved.

Sub-Setting	Details
Charge Mode	<ul style="list-style-type: none"> <li>Plug and Charge: No authentication required – plug the charger into the vehicle and charging will begin. No network connection is required.</li> <li>Local RFID List: Control access by only allowing sessions to begin when an authorized RFID card has been tapped (See RFID block on previous page). No network connection is required.</li> <li>OCPP: Choose this when connecting the Watti Pro Lite to the Electric Avenue OCPP Central Server or other OCPP Central Servers.</li> </ul>

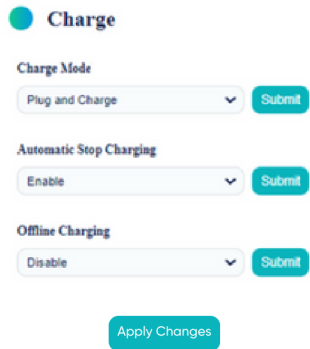

# CHARGER MANAGEMENT BACKEND

## CONFIGURING DEVICE SETTINGS

### CHARGE BLOCK (CONTINUED)

Sub-Setting	Details
Automatic Stop Charging	<p>Sets the desired operation when the car has reached its charge limit.</p> <ul style="list-style-type: none"> <li>• Enable (default) - After a charging session finishes, if the battery falls below its initial charge limit, the charger will continue supplying energy to the vehicle. This is also useful for pre-conditioning the vehicle, in which the energy required for pre-conditioning will be drawn from the charger.</li> <li>• Disable - The charger will end the charging session and will no longer send additional energy to the vehicle, even if the battery drains while the cable is still plugged in.</li> </ul>
Offline Charging	<p>Sets the desired operation of the charger when a connection to the OCPP Central Server is lost.</p> <ul style="list-style-type: none"> <li>• Enable - Allows the vehicle to continue to charge without a connection to the OCPP server (ie. during a network outage).</li> <li>• Disable (default) - Does not allow charging when connection to the OCPP Central Server is lost.</li> </ul>

**Charge**

**Charge Mode**

Plug and Charge

**Automatic Stop Charging**

Enable

**Offline Charging**

Disable

### CONFIGURING MAINTAIN SETTINGS

Device
**Maintain**
Operate
A admin
⚙️

Sub-Setting	Details
Upload	This section is used to upload new firmware files and alternate CA Certificates.
Download	Download charging data (not yet supported).
Maintain	Not used by installers or operators. Electric Avenue use only.

**Upload**

Please select what to upload

Update System Firmware

No file chosen

---

**Download**

Please select what to download

Charging Record 0

---

**Maintain**

Please input command

# CHARGER MANAGEMENT BACKEND

## CONFIGURING OPERATE SETTINGS

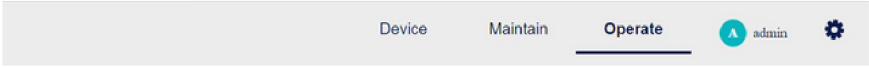

Sub-Setting	Details
Restore Factory Settings	Resets the charger to the factory default settings

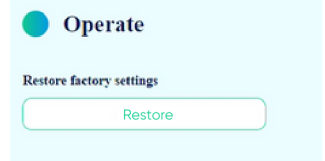

## SETTINGS



Sub-Setting	Details
Theme	Select desired interface theme for the page (Light/Dark).
Language	Select desired language from English, French, and Spanish.
Change Username	Change Charger Management Backend login username
Change Password	Change Charger Management Backend login password
Reset Account	Resets the Charger Management Backend login username and password to admin/admin
Log Out	Logs the current user out of the Charger Management Backend and return to login page
Reboot Device	The device will power off and back on automatically. All submitted settings will be saved.

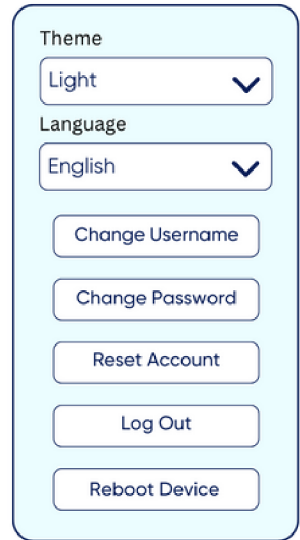

## WARRANTY

Electric Avenue offers a three (3) year limited warranty in the event a defect occurs with an Electric Avenue EV charger. Electric Avenue guarantees that EV chargers shall be free of manufacturer defects. The warranty is applicable to the original purchaser only and is non-transferable. This warranty will be void if any original parts have been changed or any attempt to repair a non-working EV charger has been made by anyone other than authorized Electric Avenue personnel. This warranty is void if the EV charger was used in a manner other than the specified operating range or was used in an application not intended for the EV charger. This warranty is void if the EV charger is altered or modified.

### Warranty Exclusions:

- Damage or rendered non-functional because of power surges, lightning, earthquake, fire, flood, pest damage, abuse, accident, misuse, negligence, or failure to maintain the product or other event beyond Supplier's reasonable control or not arising from the normal operating condition.
- Cosmetic or superficial defects, dents, marks, or scratches after use.
- Components that are separate from the product, ancillary equipment, and consumables, such as door key, RFID card, air filter, fuse, cable, wires, and connectors.
- Damage because of modifications, alterations, or disassembling which were not preauthorized in writing by Supplier.
- Damage due to the failure to observe the applicable safety regulations governing the proper use of the product.
- Installed or operated not in strict conformance with the documentation, including without limitation, not ensuring sufficient ventilation for the product as described in the Supplier installation instructions.

If a defect occurs during the warranty period, the unit(s) or parts must be returned in accordance with the return policy. A copy of the original invoice or other proof of purchase must accompany the returned unit(s) or parts. Electric Avenue reserves the right to repair or replace, at our option, any defective EV charger within the warranty period. Electric Avenue is under no obligation to repair or replace EV chargers that have components blown out by use of excessive loads or input conditions beyond the stated range of the EV charger specification.

To file a warranty claim, contact Electric Avenue support by phoning 1-888-353-2283 or send a detailed email to [support@goelectricave.com](mailto:support@goelectricave.com).









**Always Be Charging**