

Smart Home
EV Charger

INSTALLATION & USAGE GUIDE

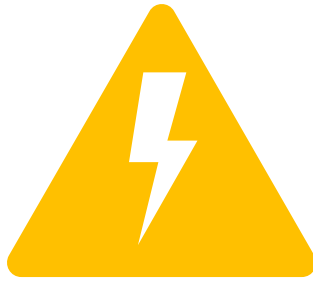

WARNING - RISK OF ELECTRICAL SHOCK!

Improper connection of the equipment-grounding conductor may result in a risk of electric shock, leading to death or serious injury. Electric Avenue recommends that installation be performed by a licensed electrician or other qualified professional in accordance with the regional electrical code where it is being installed to ensure the Watti Home is properly grounded. Do not modify the provided plug – if it will not fit the outlet, have a proper outlet installed by a licensed electrician or other qualified professional.

GROUNDING INSTRUCTIONS

The electrical system must be grounded. If the Watti Home EV Charger should malfunction or break down, grounding provides a path of least resistance for electric current to reduce the risk of electric shock. The Watti Home EV Charger is equipped with a cord having an equipment-grounding conductor and a grounding plug. The plug must be plugged into an appropriate receptacle that is properly installed and grounded in accordance with all local codes and ordinances. In accordance with National Electric Code, breakers should be rated for at least 125% of the Watti Home EV Charger's continuous load.

SAFETY INFORMATION

Read these instructions before using the EV Charger.

- Charging should be supervised when used around children.
- Do not put fingers in EV connector.
- The Watti Home EV Charger is intended for use with electric vehicles only.
- Specifically, it is intended only for electric vehicles not requiring ventilation during charging.
- Do not use the Watti Home EV Charger in any manner other than specified in this installation guide.
- Do not attempt to disassemble or repair any of the components of the Watti Home EV Charger. There are no user serviceable parts inside.
- If you believe the charging station, cables, or connector gun may have been damaged in any way; do not attempt to use them.
- Do not install the Watti Home EV Charger in environments with explosive gas or vapors; nor in damp or wet environments; nor where temperatures are outside its operating range of -22°F to 122°F (-30°C to 50°C)

WHAT'S IN THE BOX

Your new Watti Home EV Charger contains the following items. If any of these items are missing or if you believe they've been damaged, call support immediately.

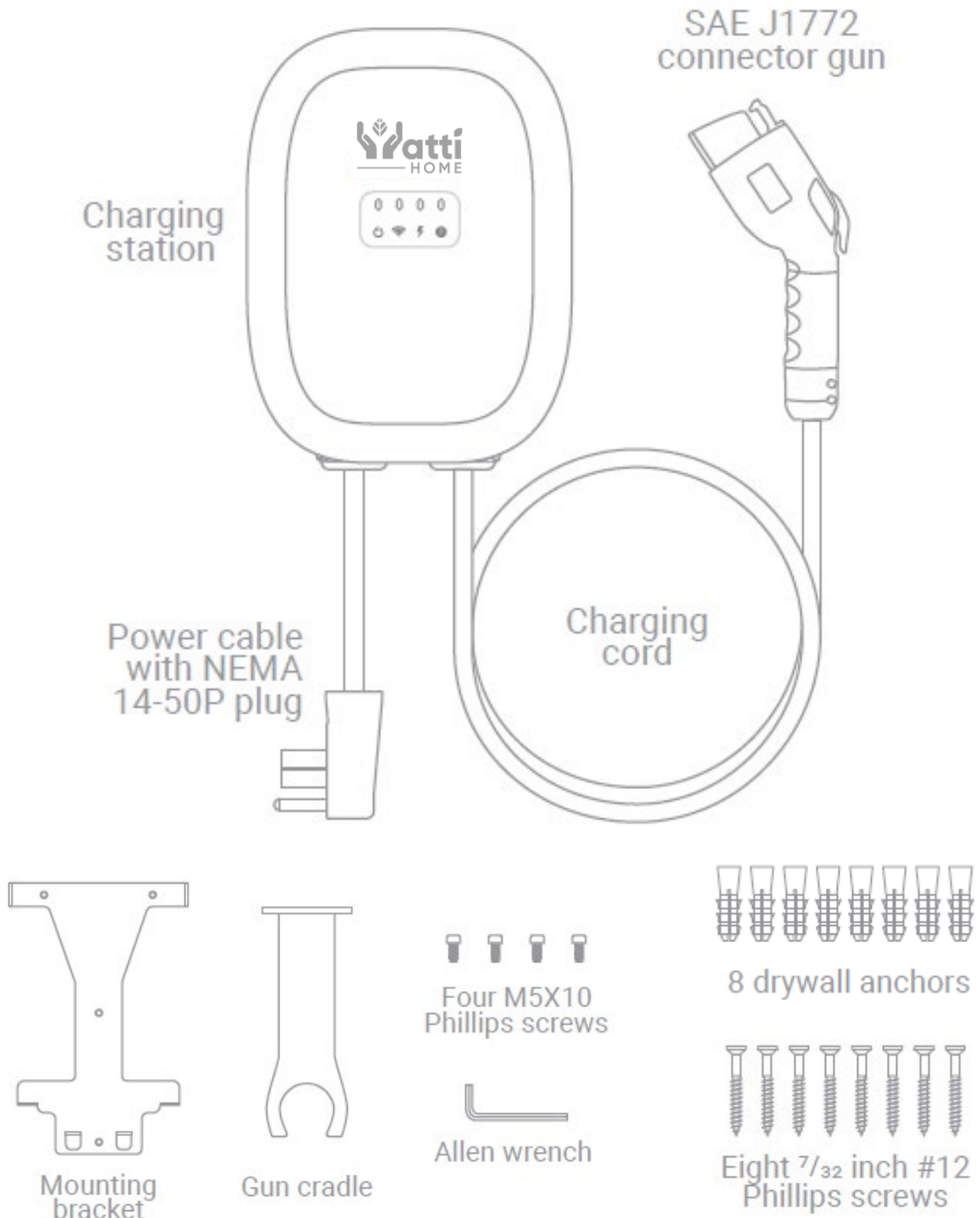

BEFORE YOU GET STARTED

Here are the tools you will need to install the EV Charger.



Phillips and flathead screwdrivers



Bubble level



Pencil



Hammer



iOS or Android phone or tablet

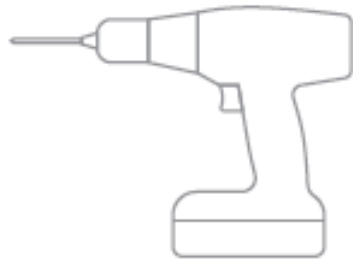

Drill with a 5/16" drill bit

Need help?
goelectricave.com
support@goelectricave.com

STEP 1: DOWNLOAD THE APP

Use your phone to check the signal strength of your Wi-Fi network where the EV Charger will be installed. Low/no signal may require a Wi-Fi extender for the Charger to work.

Download our free partner app, **Emporia Energy**, onto your phone or tablet from the Apple App Store or from Google Play.

Create an account and begin the setup process.



STEP 2: HOW IS THE EV CHARGER POWERED?





Hardwired installation See Step 8a

- EV Charger can supply a maximum charge of 48A to the EV
- Requires a dedicated dual-pole breaker. We recommend 60A.



Plugged-in installation See Step 8b

- EV Charger can supply a maximum charge of 40A to the EV
- Requires a dedicated dual-pole breaker. We recommend 50A.
- Requires a NEMA 14-50R receptacle outlet.

Dedicated Breaker	Charge Power @ 240V			
15A	2.9kW	12A	Y	Y
20A	3.8kW	16A	Y	Y
25A	4.8kW	20A	Y	Y
30A	5.8kW	24A	Y	Y
35A	6.7kW	28A	Y	Y
40A	7.7kW	32A	Y	Y
45A	8.6kW	36A	Y	Y
50A	9.6kW	40A	Y	Y
60A	11.5kW	48A	Y	N

STEP 3: FIND A PLACE FOR THE EV CHARGER

Locate a place to mount the EV charger where the charger is 24-48" above the floor/ground; the distance from the vehicle allows slack for 25' cable; temperatures are between -22°F to 122°F; the charger is within range of WiFi signal; and if plugged-in, the distance from the NEMA outlet allows slack for a short cable.

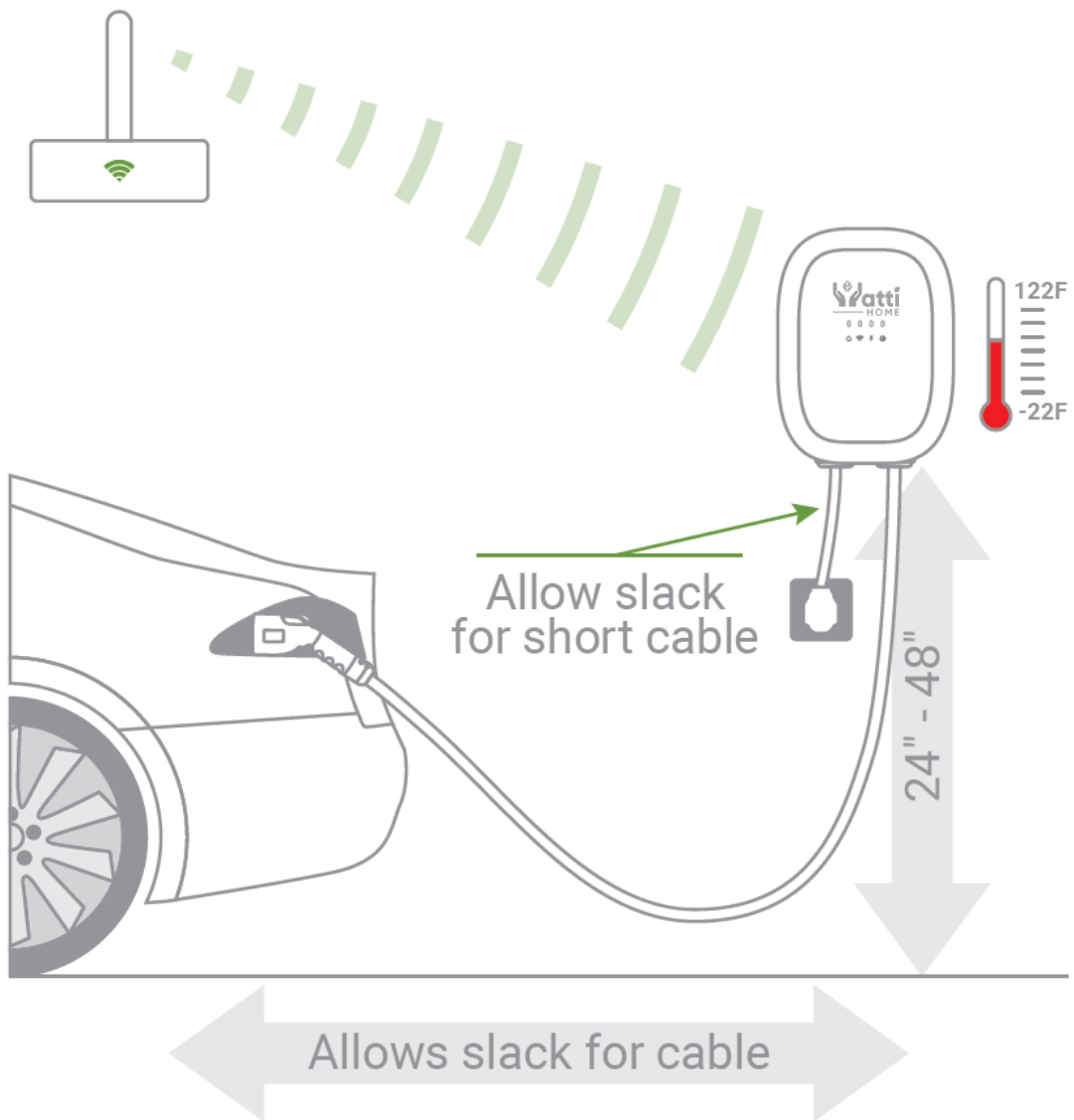

STEP 4: MARK THE MOUNTING BRACKET LOCATION

Use a bubble level to draw a horizontal line where the top of the EV Charger will sit on the wall ensuring it is 24-48" above the floor/ground and allows slack for the NEMA cable if it will be plugged in. Then, align the top of the mounting bracket to the line and mark the 4 mounting holes.

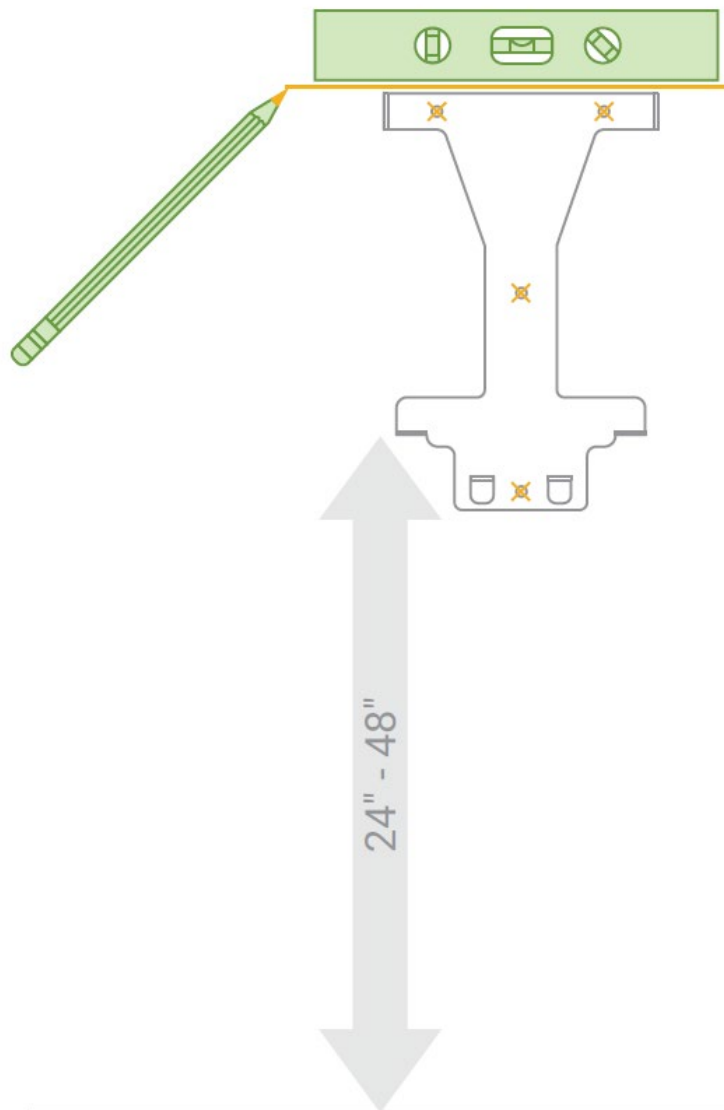

STEP 5: INSTALL THE MOUNTING BRACKET

For each mark, drill a 5/16" hole in the wall. Use a hammer to tap in the 4 drywall anchors. **If you would like to install the gun cradle under the EV Charger**, install the mounting bracket with 3 Phillips screws into the top 3 anchors, omitting the bottom screw, and go to Step 6a. **If you'd like to install the gun cradle off to the side of the EV Charger**, install the mounting bracket with the 4 Phillips screws into the anchors and proceed to Step 6b.

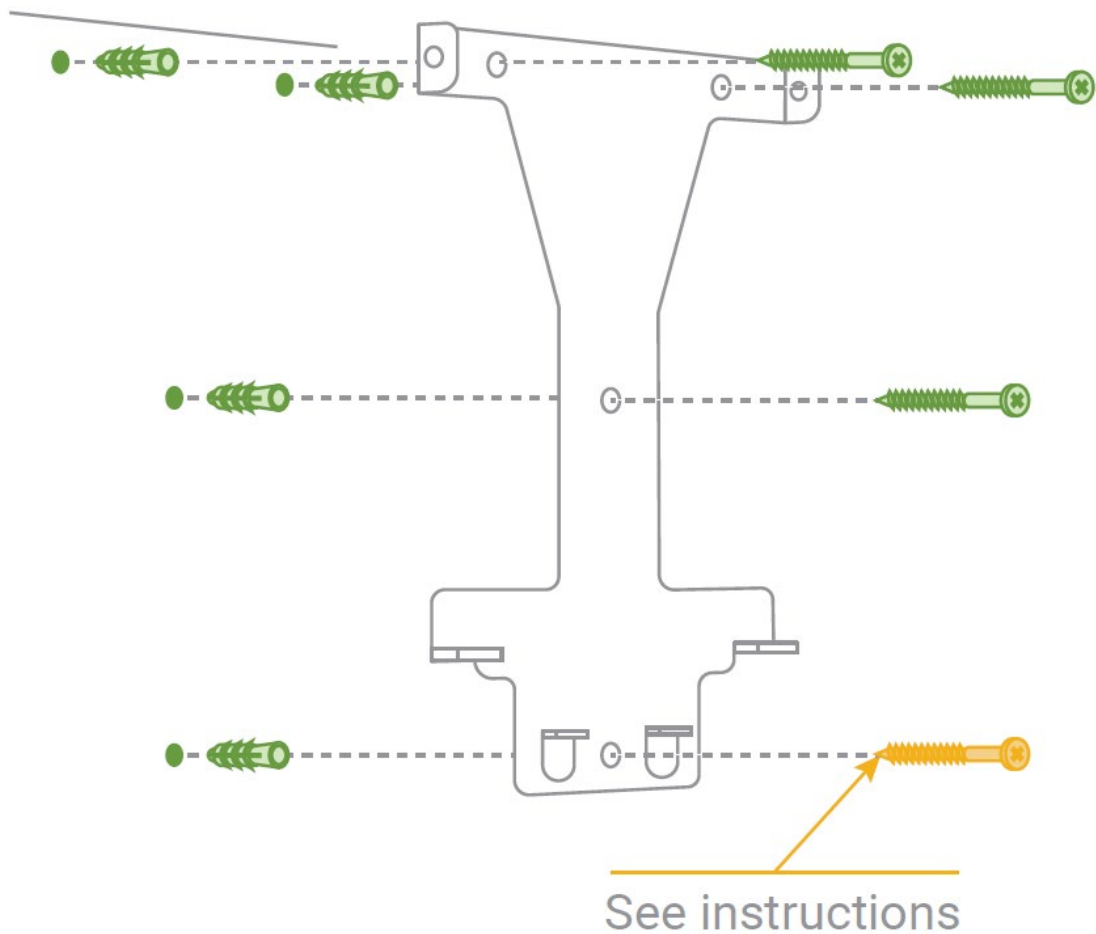

STEP 6: INSTALL THE GUN CRADLE UNDER THE CHARGER

The gun cradle is designed to be installed directly under the EV Charger. **If you wish to install it off to the side of the EV Charger, skip to Step 6b.** Hang the gun cradle on the mounting bracket hooks. Mark the bottom mounting hole of the gun cradle. Drill a 5/16" hole in the wall at your mark. Use a hammer to tap in a drywall anchor. Install the gun cradle with 2 Phillips screws into the anchors.

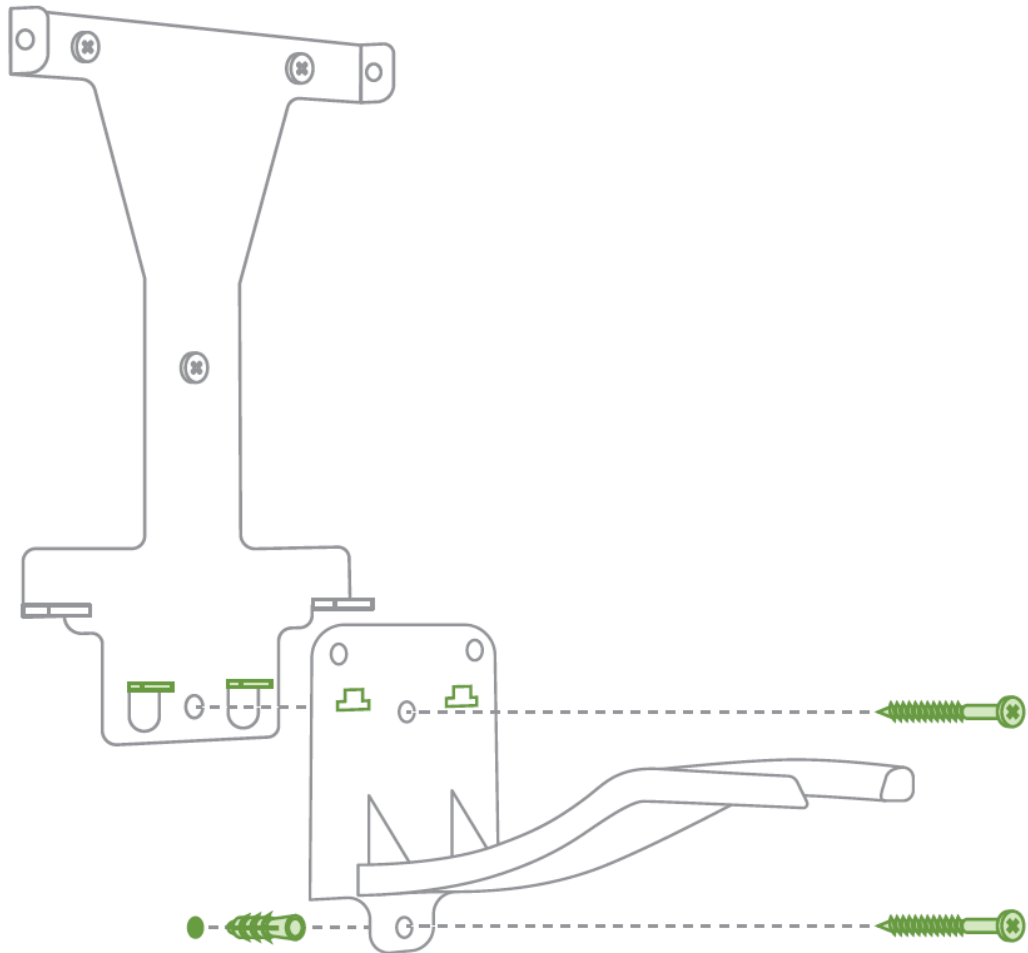

STEP 6B: INSTALL THE GUN CRADLE BESIDE THE CHARGER

Use a bubble level to draw a horizontal line at least 12" away from the mounting bracket at the height you'd like the cradle beside your EV Charger. Holding the gun cradle up to your line, mark the top two and bottom mounting holes of the gun cradle. Drill a 5/16" hole in the wall for each mark. Use a hammer to tap in 4 drywall anchors. Install the gun cradle with 4 Phillips screws into the anchors.

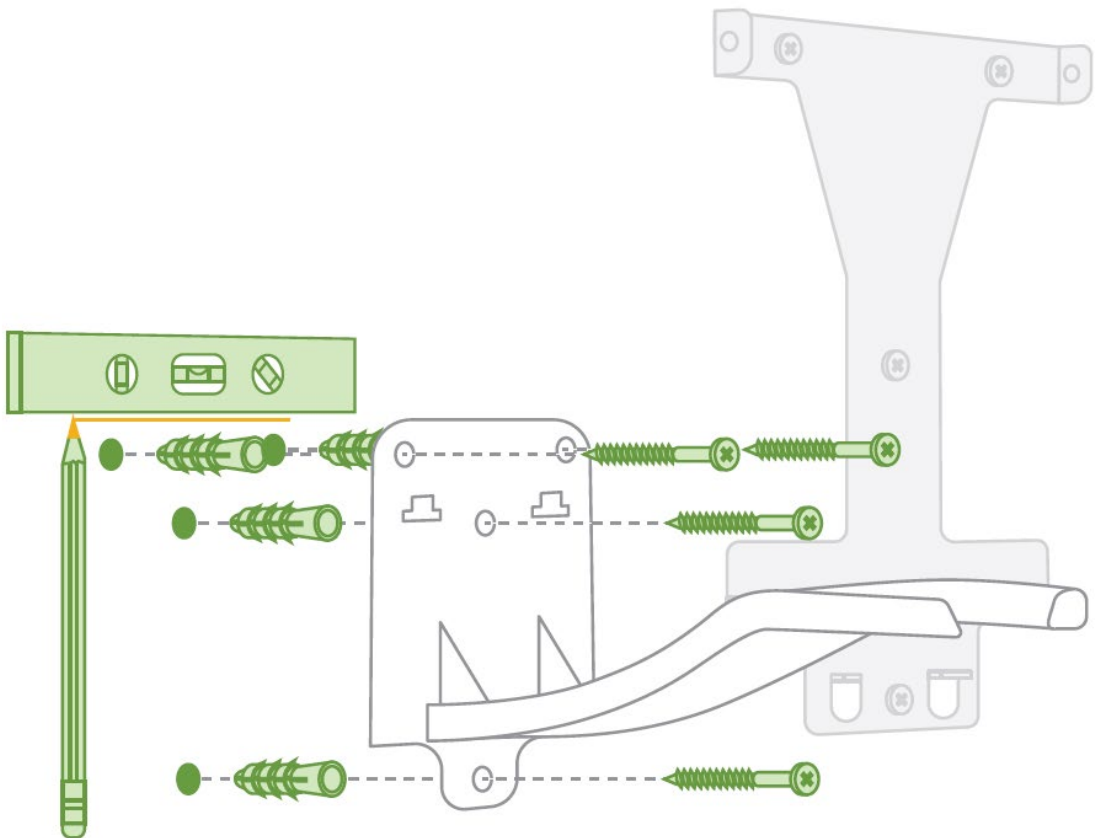

STEP 7: MOUNT THE EV CHARGER

Use a Phillips screwdriver and the 4 Phillips bolts to install the EV Charger on the mounting bracket.

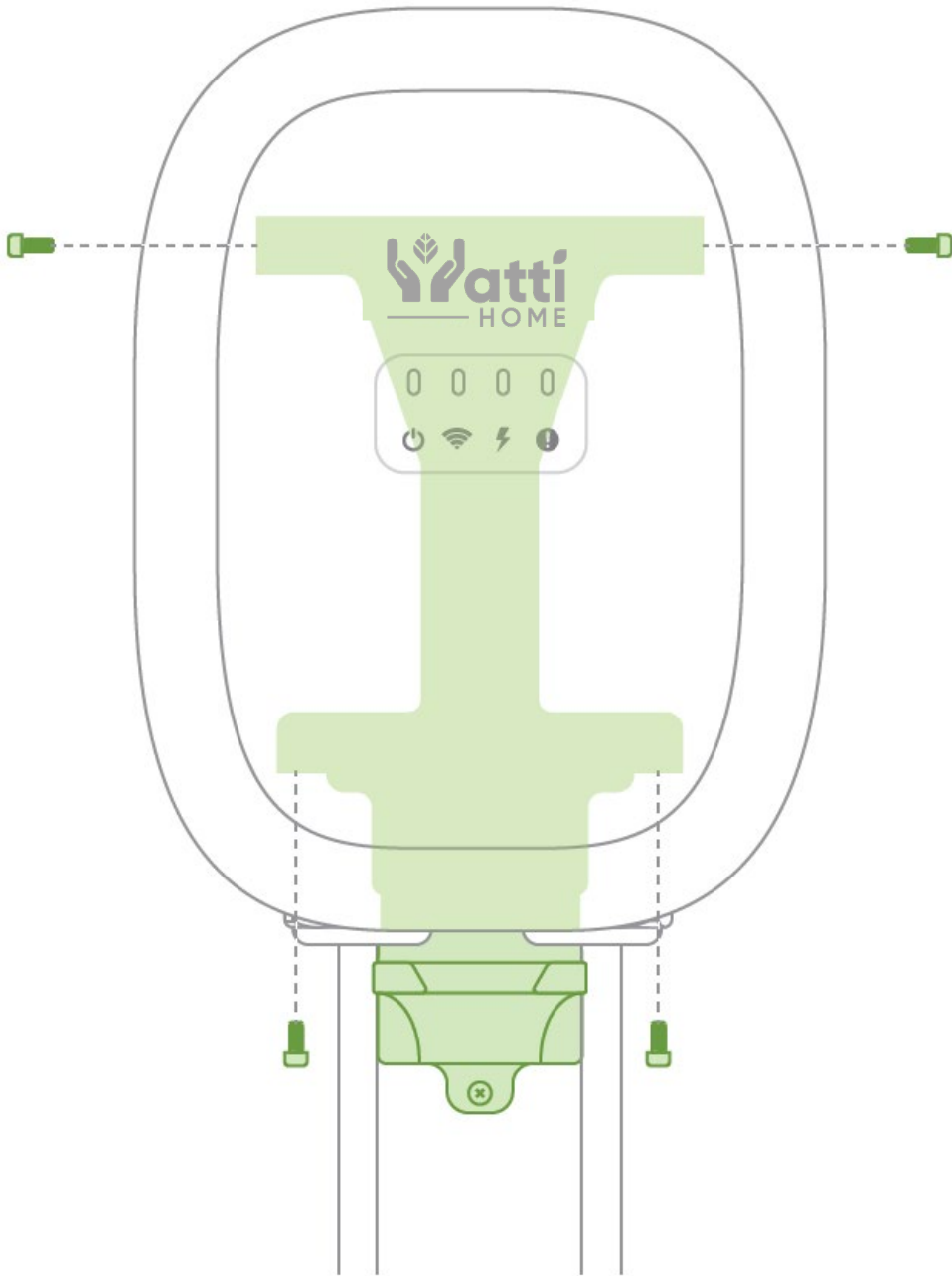



STEP 8A-1: HARDWIRED INSTRUCTIONS FOR ELECTRICIANS

A licensed electrician or other qualified professional can follow these instructions to hardwire the EV Charger to a breaker. If you plan to power your EV Charger with a NEMA 14-50R receptacle outlet, skip to Step 8b. First, turn off the dedicated dual-pole breaker that will power the EV Charger.

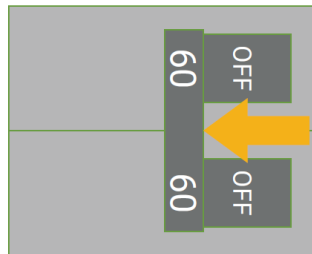

STEP 8A-2: HARDWIRED INSTRUCTIONS FOR ELECTRICIANS

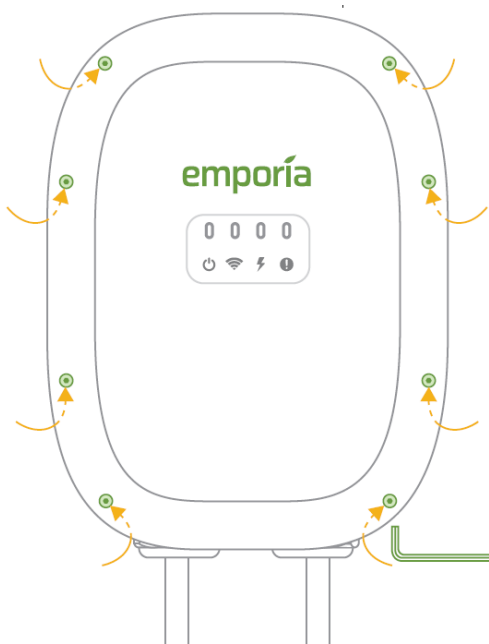

From the back of the EV Charger, use the Allen wrench to remove the 8 screws to detach the front cover. Caution: there's a cable connecting the cover to the circuit board in the Charger. To remove the cable, gently grab the cable bundle and pull it away from the circuit board.



STEP 8A-3: HARDWIRED INSTRUCTIONS FOR ELECTRICIANS

Unscrew the screws for terminals 1, 2, and 3 to remove the Black, Red, and Green NEMA cable wires.

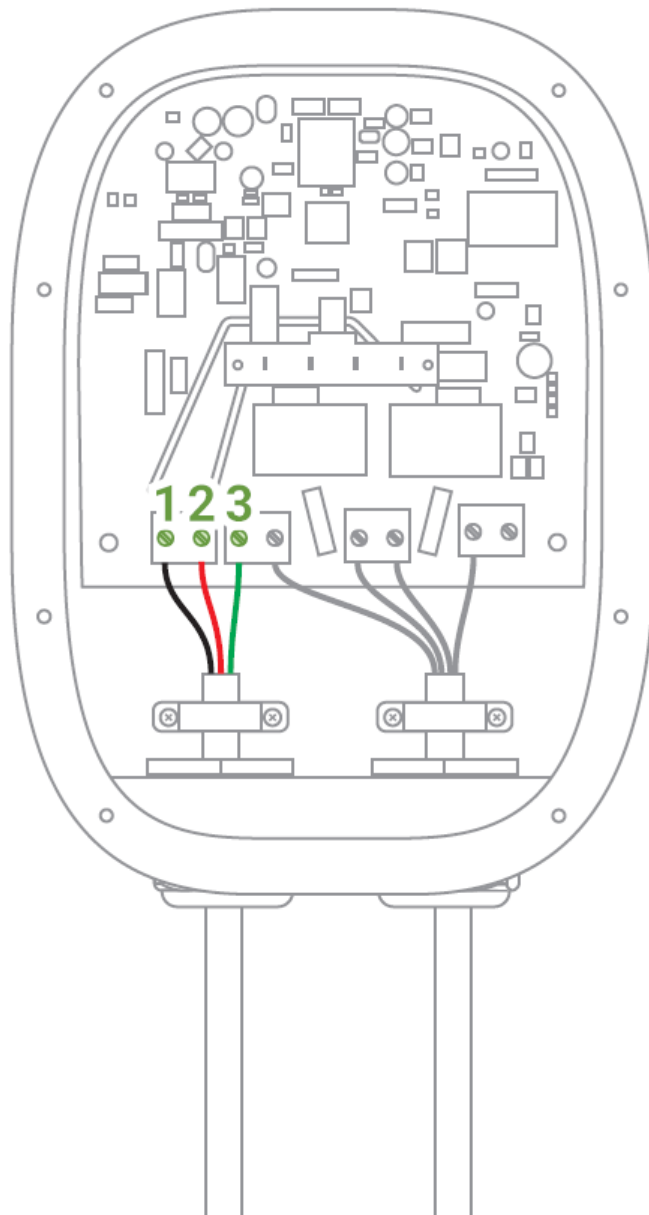



STEP 8A-4: HARDWIRED INSTRUCTIONS FOR ELECTRICIANS

Unscrew the screws to remove the clamp securing NEMA cable. Then, remove the NEMA cable from the assembly. Finally, unscrew the nut holding the cable gland in place and remove it from the assembly.

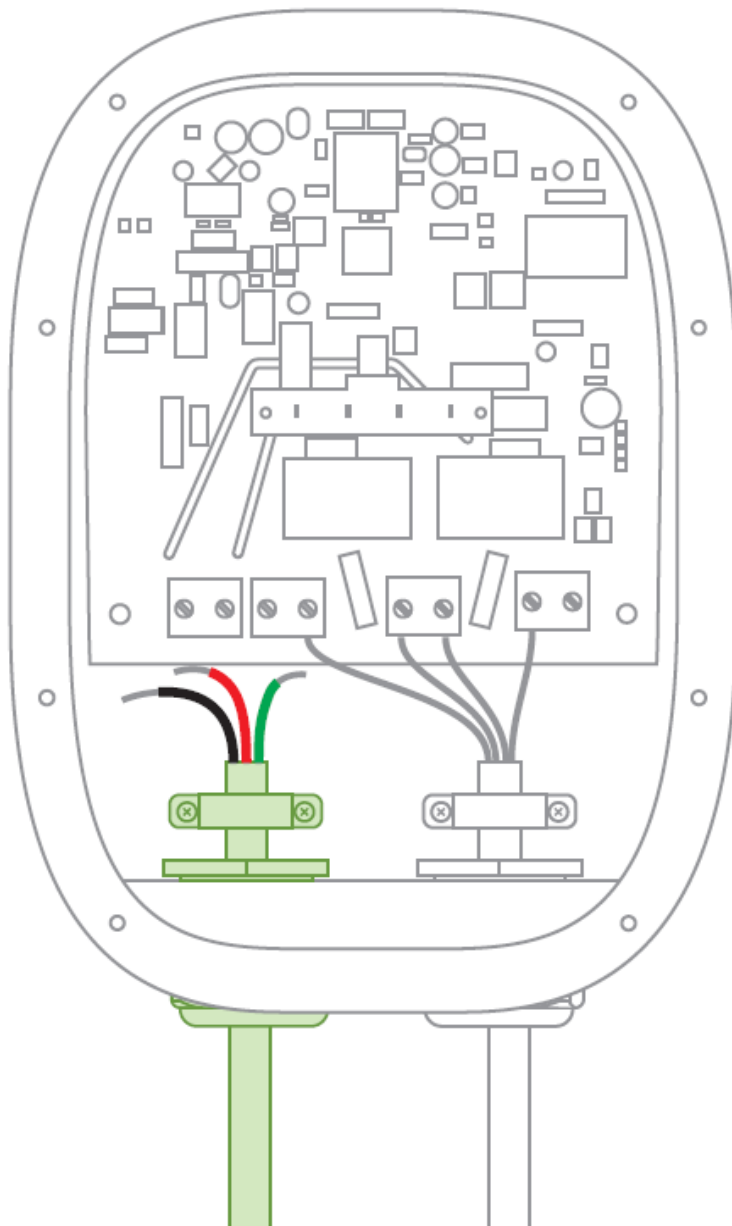



STEP 8A-5: HARDWIRED INSTRUCTIONS FOR ELECTRICIANS

Using 1-1/4" conduit and proper fittings for the connections, bring 6AWG leads with a temperature rating at or above 75°C (e.g., type THHN) from both phases of the breaker along with a ground/earth lead into the EV Charger assembly. Insert the phase 1 lead into terminal 1, the phase 2 lead into terminal 2, and the ground into terminal 3 and secure them with the screws.

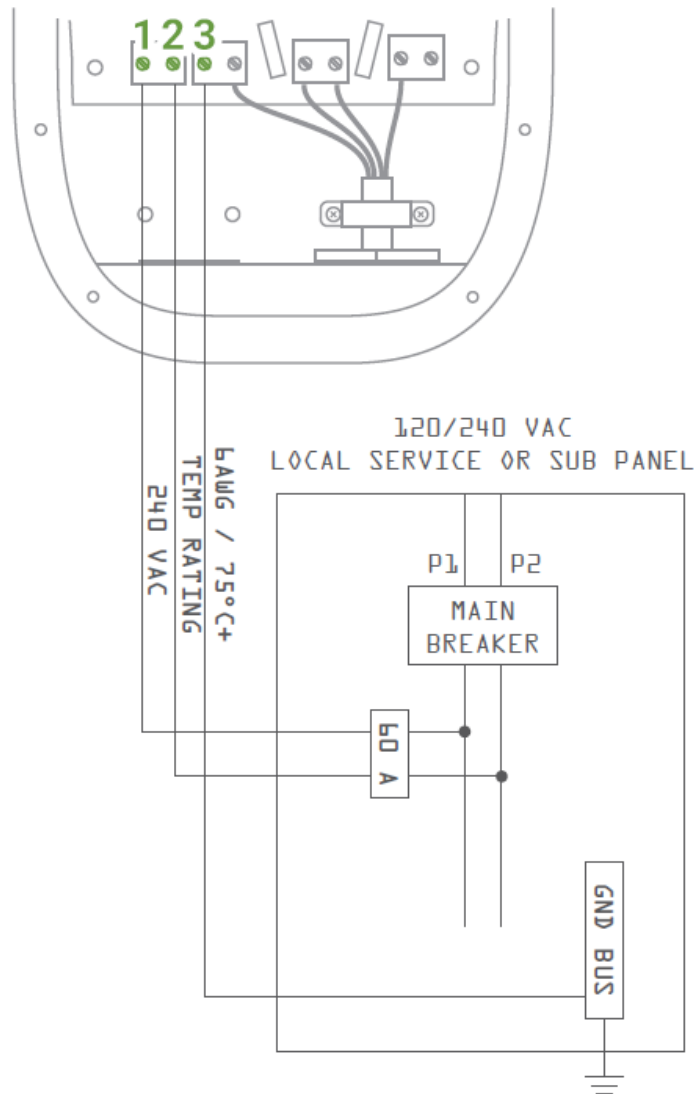



STEP 8A-6: HARDWIRED INSTRUCTIONS FOR ELECTRICIANS

Gently reattach the cable to the cover and the circuit board. Then, from the back of the EV Charger, use the Allen wrench to replace the 8 screws to reattach the front cover.

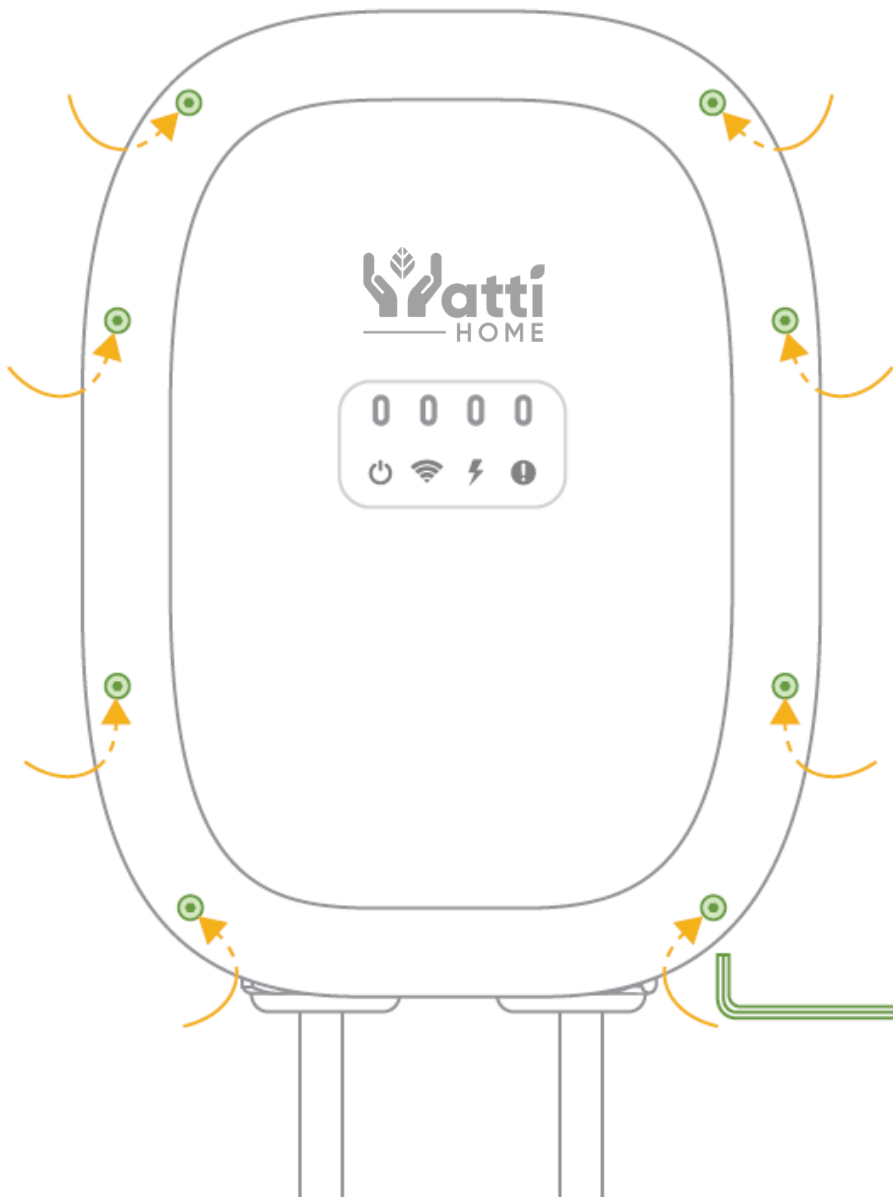



STEP 8A-7: HARDWIRED INSTRUCTIONS FOR ELECTRICIANS

Turn on the breaker and ensure that the power light on the front of the EV Charger is illuminated.

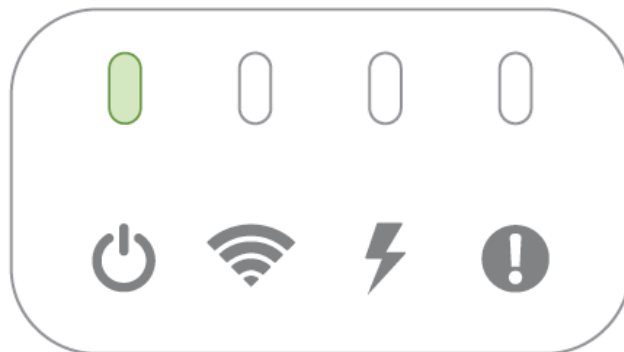
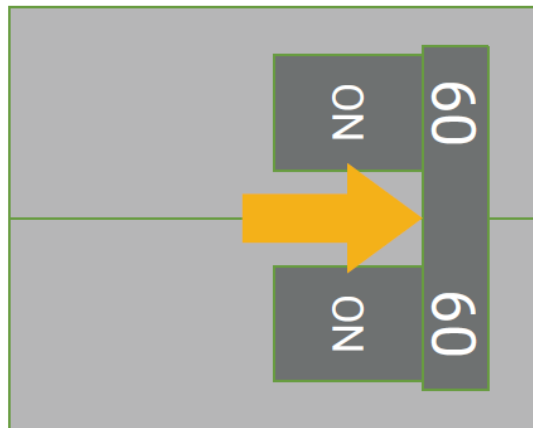

Need help?
goelectricave.com
support@goelectricave.com



STEP 8B-1: PLUGGED IN INSTRUCTIONS FOR ELECTRICIANS

If a NEMA 14-50R receptacle outlet is not already at the EV Charger location, a licensed electrician or other qualified professional can follow these instructions to install one. First, turn off the dedicated dual-pole breaker that will power the EV Charger.

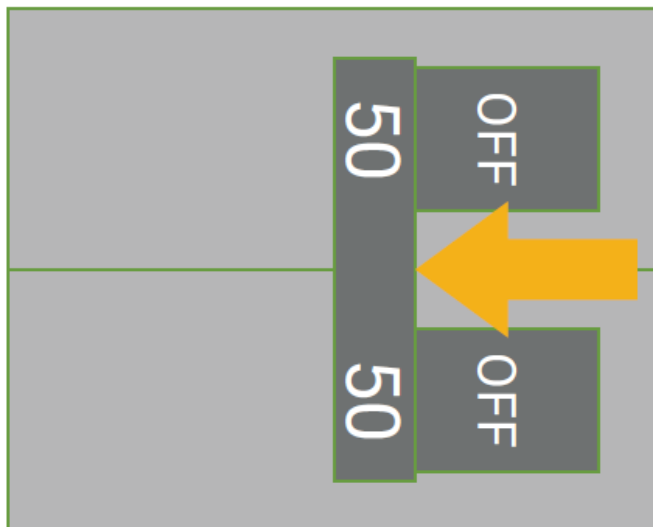

Need help?
goelectricave.com
support@goelectricave.com



STEP 8B-2: PLUGGED IN INSTRUCTIONS FOR ELECTRICIANS

Install a NEMA 14-50R receptacle outlet with the ground facing downward ensuring the distance between the NEMA outlet and the EV Charger allows slack for a short cable. Bring leads from both phases of the breaker along with a ground/earth lead to the outlet and connect them. **Neutral is not required.**

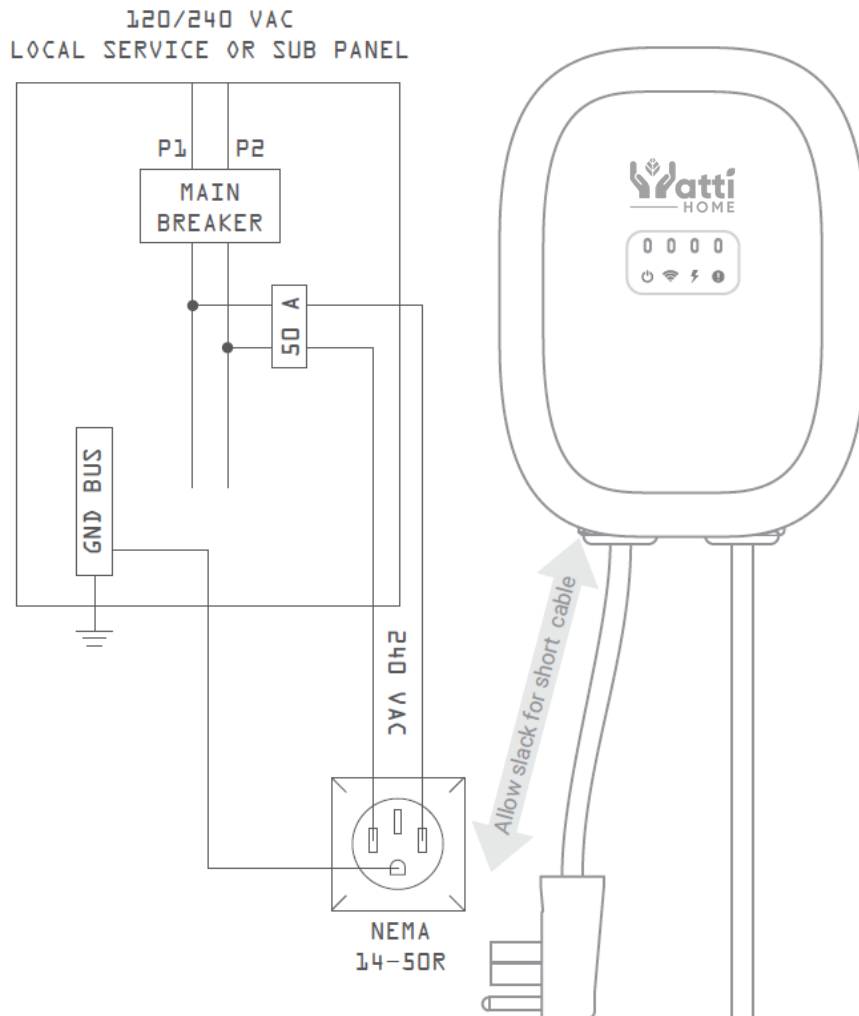



STEP 8B-3: PLUGGED IN INSTRUCTIONS FOR ELECTRICIANS

Plug in the NEMA 14-50P plug from the EV Charger into the receptacle outlet. Turn on the breaker and ensure that the power light on the front of the EV Charger is illuminated.

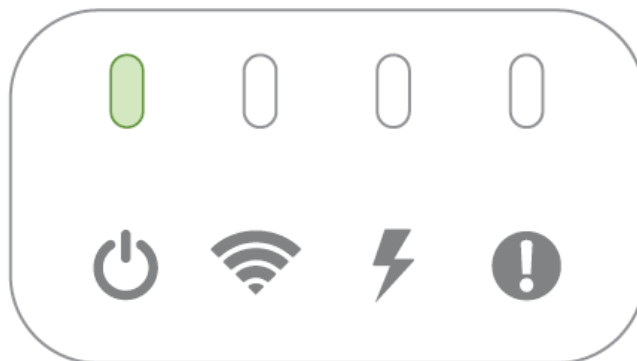
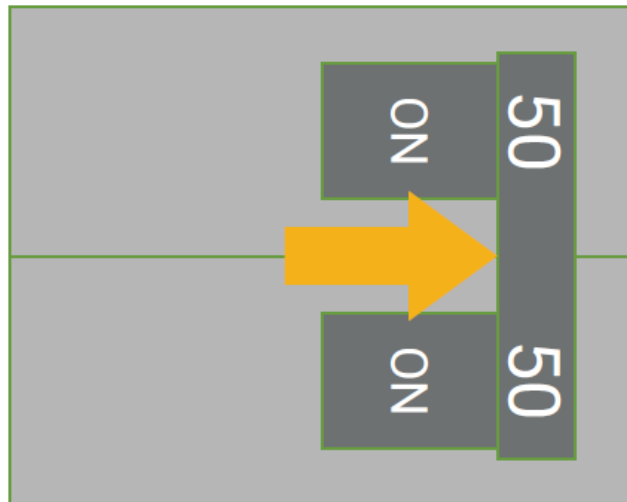

STEP 9: COMPLETE THE SETUP

Your EV Charger is now ready to charge your vehicle. It is set from the factory to charge at 40 Amps. To change the charge rate to match your breaker size and to take advantage of the numerous other features available from Watti Home, return to our partner app, Emporia Energy, choose Add a Device under Manage Devices and follow the instructions to set up your EV Charger. Your phone will connect via Bluetooth to the system and then you'll connect to a nearby Wi-Fi router. Make sure you have your Wi-Fi name and password.



Need help?
goelectricave.com
support@goelectricave.com

CHARGING YOUR VEHICLE

Your charger is set from the factory to charge at 40 Amps. You can only change this rate through the Electric Avenue Home app. To charge your vehicle, open the port door and plug the EV Charger gun into the port. You will see the charge light on the EV Charger switch to solid blue when it is connected to the vehicle. It will begin breathing blue as the vehicle charges. Additionally, most Evs have indicator lights on the dashboard to let you know that you're charging. Do not attempt to drive your vehicle while the charging cable is connected to your vehicle.

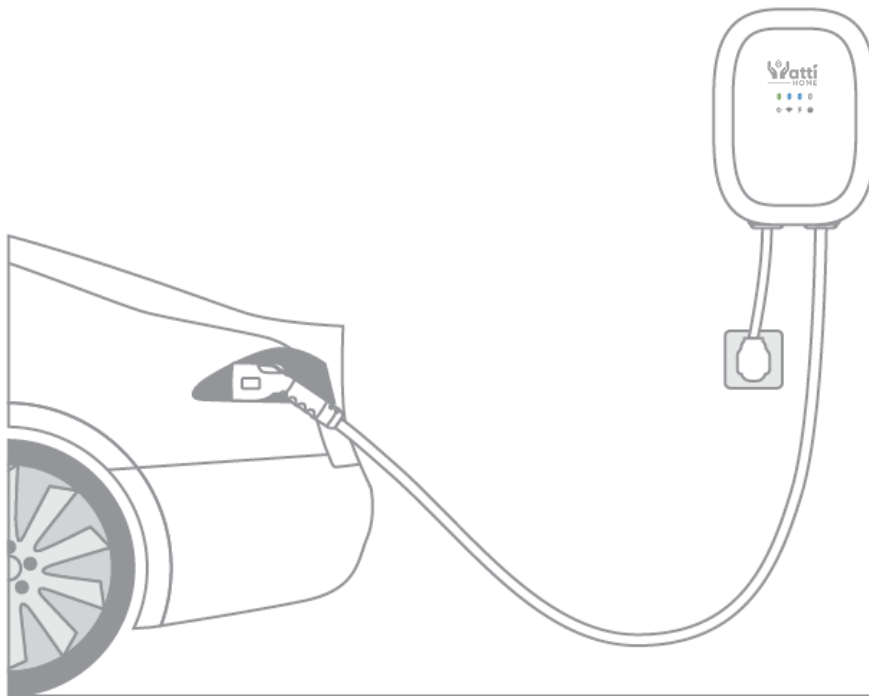

Need help?
goelectricave.com
support@goelectricave.com

CHARGING YOUR TESLA EV

The Watti Home EV Charger requires a Tesla J1772 adapter to charge a Tesla. If you don't already own one, these can be purchased directly from shop.tesla.com.

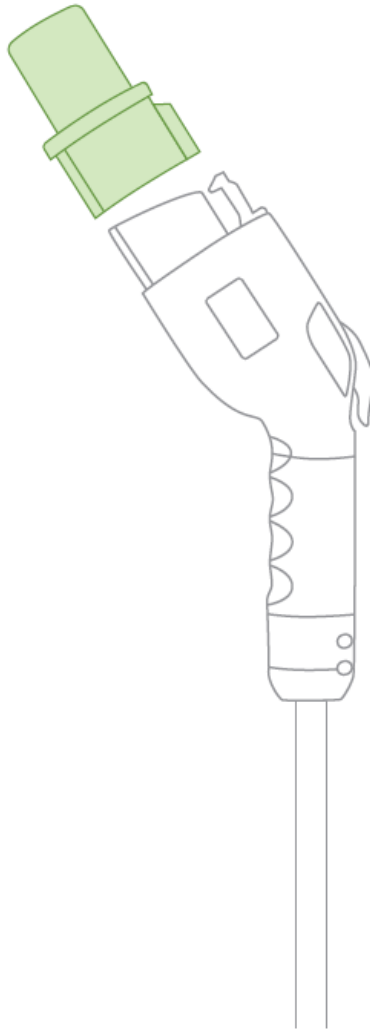





Need help?

goelectricave.com

support@goelectricave.com

EV CHARGER LED LIGHTS

 Power	
Off	Charger does not have power
Solid green	Charger has power
 Charge	
Off	No vehicle connected
Solid Blue	Vehicle connected
Flashing Blue	Preparing to charge
Breathing Blue	Vehicle charging
 WiFi	
Solid Red	Not connected to router
Flashing Red	Lost connection to router
Flashing Green	Connecting to router
Solid Green	Connected to router, but not the Internet
Solid Blue	Connected to the router and the Internet
 Fault	
Flashing orange 1 slow/1 fast	Abnormal control pilot circuit Unplug and plug-in Emporia EV Charger. If issue persists, contact Support.
Flashing orange 1 slow/2 fast	Charger has exceeded operating temperature lower bound. Ensure the charger is installed where temperatures do not drop below -22F (-30C)
Flashing orange 1 slow/3 fast	Input voltage is too low If plugged in, check that the NEMA 14-50P is plugged in securely. Check the supply breaker in your breaker panel for damage and replace if necessary. If issue persists, contact Support.
Flashing orange 1 slow/4 fast	Input voltage is too high If plugged in, check that the NEMA 14-50P is plugged in securely. Check the supply breaker in your breaker panel for damage and replace if necessary. If issue persists, contact Support.
Flashing orange 1 slow/5 fast	Charger has exceeded nominal temperature Ensure the charger is installed where ambient temperatures will not exceed 122°F (50°C). If issue persists, contact Support.

EV CHARGER LED LIGHTS (Continued)

! Fault (cont.)	
Flashing orange 1 slow/6 fast	Output surge current Unplug from car. Disconnect charger from power. Confirm there is no visible damage or foreign material in the EV gun. Return power to charger. If issue persists, contact Support.
Flashing orange 1 slow/7 fast	Current leakage Unplug from car. Disconnect charger from power. Confirm there is no visible damage or foreign material in the EV gun. Return power to charger. If issue persists, contact Support.
Flashing orange 1 slow/8 fast	Output short circuit Unplug from car. Disconnect charger from power. Confirm there is no visible damage or foreign material in the EV gun. Return power to charger. If issue persists, contact Support.
Flashing orange 1 slow/9 fast	Output over current Unplug from car. Disconnect charger from power. Confirm there is no visible damage or foreign material in the EV gun. Return power to charger. If issue persists, contact Support.
Flashing orange 2 slow/1 fast	Vehicle is not responding. Ensure that the latch on the EV charging cable handle is locked into place. If the handle is not latched securely, the vehicle will not charge. If the latch is pressed down during charging, charging automatically stops. Ensure that the vehicle is not set up to begin charging at a specific time of day.
Flashing orange 2 slow/2 fast	Vehicle interface issue. Ensure that the latch on the EV charging cable handle is locked into place. If the handle is not latched securely, the vehicle will not charge. If the latch is pressed down during charging, charging automatically stops. Ensure that the vehicle is not set up to begin charging at a specific time of day.
Flashing orange 2 slow/3 fast	Relay fused in position Disconnect from power immediately. Contact Support.
Flashing orange 2 slow/5 fast	Charger is not grounded Ensure that the EV Charger is properly wired and grounded. Check the line and neutral connections, as they may be reversed in the adapter or outlet. Unplug and reboot EV charger. If issue persists, contact Support.
Flashing orange 3 slow/1 fast	The car is requesting ventilation during charging, which is not supported by the Emporia EV Charger. Contact Support.

TROUBLESHOOTING TIPS

The Electric Avenue Home app is not finding my EV Charger after I've installed it.

- Ensure the Charger has power:
 - Check for a green power light.
 - Check the EV Charger is wired properly.
 - Check that the breaker powering the EV Charger is turned on.
- Ensure your phone can connect to the EV Charger.
 - Check your phone's Bluetooth is on.
 - If you're using an Android, turn on Location Services for your phone to properly scan for Bluetooth devices.
- Try power cycling the breaker to which the EV Charger is connected.
- Try restarting the Electric Avenue Home App.
- Try rebooting your phone.

My vehicle is not responding or charging.

- Ensure that the latch on the EV charging cable handle is locked into place. If the handle is not latched securely, the vehicle will not charge. If the latch is pressed down during charging, charging automatically stops.
- Ensure that the vehicle is not set up to begin charging at a specific time of day.

Need help?

goelectricave.com

support@goelectricave.com



FCC ID:
2AS6P-EMEVSE1
Model: EMEVSE1

The Watti Home Smart EV Charger contains FCC ID: 2AS6P-EMEVSE1. This device complies with part 15 of the FCC Rules. Operation is subject to the following two conditions: (1) this device may not cause harmful interference, and (2) this device must accept any interference received, including interference that may cause undesired operation. This equipment complies with FCC RF radiation exposure limits set forth for an uncontrolled environment. This equipment should be installed and operated with a minimum distance of 20 centimeters between the radiator and your body.

CAUTION: Any changes or modifications not expressly approved by Electric Avenue Manufacturing Inc. void the user's authority to operate the equipment.

Need help?

goelectricave.com

support@goelectricave.com