

30kW Wall Mount DC Fast Charger

User Manual & Installation Instructions

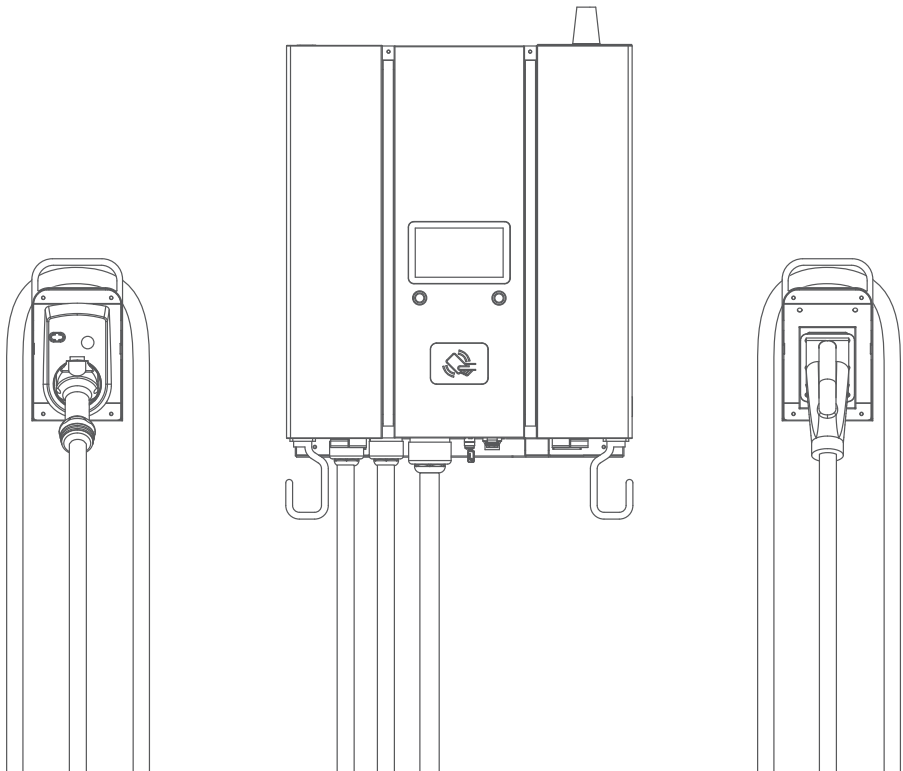

info@goelectricave.com

Copyright © 2022, Electric Avenue Manufacturing Inc.

Electric Avenue reserves the right to update the manual without any notice.

CONTENT

Introductions	1
Features	1
Applications	1
1. Basic User Interface	2
2. Specification	3
2.1 Product Specification	3
2.2 WD30 Version Description	5
2.2 LED Indication and Operation Status	5
2.3 Dimmensions	7
2.4 Direction of cooling Airflow	8
3. Installation Instruction	9
3.1 Before Installation	9
3.2 Grounding and Safety Requirement	10
3.3 Unpack the charger	12
3.4 Recommended Tools for Installation and Inspection.....	15
3.5 Installation Procedure	16
3.6 Installation Inspection & Commissioning	21
4. Network Setting	24
4.1 Wi-Fi Network Setting	24
4.2 3G/4G Setting	26
4.3 Time setting	28
5. Operation Process	30
5.1 Operating Sequence	30
5.2 Operating Procedure	30
5.3 Troubleshooting	36
5.4 Status Codes	36
6. Maintenance	57
6.1 General Maintenance.....	57
6.2 Replacement Kits and Accessories	58
7. Limited Product Warranty.....	59
Appendix - Package list.....	60

Introductions

The Watti Direct 30kW Wall Mount DC Fast Charger is the top choice to power battery electric vehicles (BEV) and plug-in electric vehicles (PHEV). It is designed for quick charging in both public and private locations, such as retail and commercial parking spaces, fleet charging stations, highway service areas, workplace, residence, etc.

The Watti Direct 30kW Wall Mount DC Fast Charger has the advantage of easy installation. The wall-mounted design and pluggable power modules realize flexible and cost-effective installation for different types of locations. The DC Wall-Mounted charger also has network communication capability. It is able to connect with remote network systems and provide drivers of electric cars real-time information, such as the location of charging stations, charging progress and billing information. The Watti Direct 30kW Wall Mount DC Fast Charger has a clear user interface with function buttons, safety certifications and an excellent waterproof and dust proof design to provide the best choice for outdoor environments.

Features

- Wall-Mounted design and pluggable power modules make installation easy and flexible.
- Offers customers the convenience of start/stop charging control from an authorized RFID smart card or mobile APP.
- Built on latest industry standards for DC charging.
- Carries an outdoor rating capable of withstanding solid and liquid intrusions in outdoor settings making the unit more stable and highly reliable.
- Provides a high-contrast, screen interface with multi-function buttons.

Applications

- Public and private parking areas
- Community parking areas
- Parking areas of hotels, supermarkets and shopping malls
- Workplace parking areas
- Charging stations
- Highway rest areas

1. Basic User Interface

Main unit :

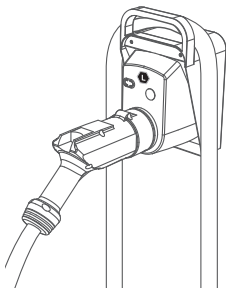
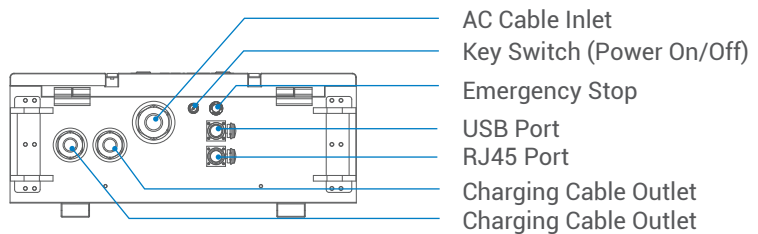
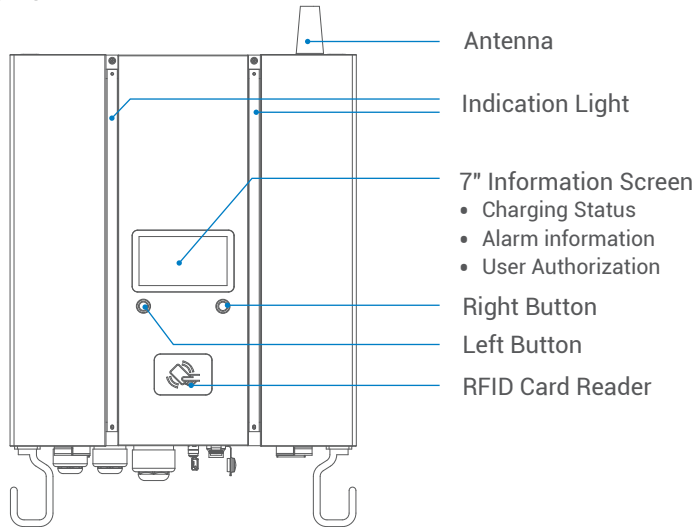

Notice: According to EN-17186 requirement, this document lays down harmonized identifiers for power supply for electric road vehicles. The requirements in this standard are to complement the informational needs of users regarding the compatibility between the EV charging stations, the cable assemblies and the vehicles that are placed on the market. The identifier is intended to be visualized at EV charging stations, on vehicles, on cable assemblies, in EV dealerships and in consumer manuals as described.

2. Specification

2.1 Product Specification

Model Name		Watti Direct 30kW Wall Mount
AC INPUT	Voltage Rating	3Φ480 Vac (+10%, -15%).
	Input current	40A
	Electrical Distribution	3P+ N +PE (Wye Configuration)
	Power Grid System	TN / TT
	Frequency	50/60Hz
	Max. Input Power	33 kVA
	Power factor	> 0.99
	Efficiency	> 94%
DC OUTPUT	Output voltage range	CHAdEMO: 150 ~ 500 Vdc CCS1: 150 ~ 950 Vdc
	Max. output current	CHAdEMO & CCS1: 500Vdc@60A CCS1: 950Vdc@31.5A
	Max. output power	30kW
	Voltage accuracy	+/- 2%
	Current accuracy	+/- 2%
User Interface	Display	7-inch LCD
	Button	Right Button : Select charging connector. (*Not applicable to this model) Left Button : Home / Stop charge
	User Authorization	RFID: support ISO 14443A/B, ISO 15693, FeliCa Lite-S (RCS966) OCPP, 2D barcode, APP, Mobile Payment
	Backend support	OCPP 1.6JSON
	Display information	*Charging process and status *Status codes
Electrical Isolation	Isolation between input and output	
Standby Power	< 100W	

Communication	External	Ethernet/4G/Wi-Fi
	Internal	CAN Bus / RS485
Input Protection	OVP, OPP, UVP, SPD	
Output Protection	SCP, OCP, OVP, LVP, OTP, IMD	
Internal Protection	OTP, AC contactor detection, DC contactor detection, Fuse detection	
Load Management	Via OCPP 1.6JSON	
Operation conditions	Operation Temperature	-30°C to 50°C (-22°F to 122°F)
	Storage Temperature	-40°C to 85°C (-40°F to 185°F)
	Relative Humidity	5%~95% RH, non-condensing
	Altitude	≤ 2000 M (6560 ft)
Regulations	Safety	UL2202, UL2231-1/-2
	EMI/EMC	FCC Part 15B
	Charging Interface	CHAdeMO : Ver 1.2 CCS1 : DIN70121 (ISO15118 by 2021/Q4)
Mechanical Specifications	Dimensions (WxDxH mm)	610 x 230 x 690
	Weight (typ.)	Dual Guns : ≤ 88kg Single Gun : ≤ 80kg
	DC Charging Connector	Refer to Chapter 2.2 Table
	Charging Cable Length	4M
	Charging Cable Number	2
	Input cable and connection	Not included
	Cooling	Forced Air
	Ingression Protection	IP55
Anti-vandalism	IK10 (does not include LCD & RFID cover)	

2.2 Watti Direct 30kW Version Description

The 30kW series are available in different versions depending on the charging connectors, below table shows the available combinations, the corresponding position of charging connectors are indicated from left to right in the view of front charger.

Version	CHAdeMO	CCS1
DWWx301 <u>J0U</u>	X	X
DWWx301 <u>J00</u>	X	-
DWWx301 <u>U00</u>	-	X

0 : none

1 : IEC 62196-2 Type 1/SAE J1772 Plug

2 : IEC 62196-2 Type 1/SAE J1772 Socket

3 : IEC 62196-2 Type 2 Plug

4 : IEC 62196-2 Type 2 Socket

5 : GB/T AC Plug

6 : GB/T AC Socket

7 : CCS2 AC Plug

J : CHAdeMO

U : Natural cooling CCS1 combo

V : Liquid cooling CCS1 combo

E : Natural cooling CCS2 combo

F : Liquid cooling CCS2 combo

G : GBT DC

2.2 LED Indication and Operation Status

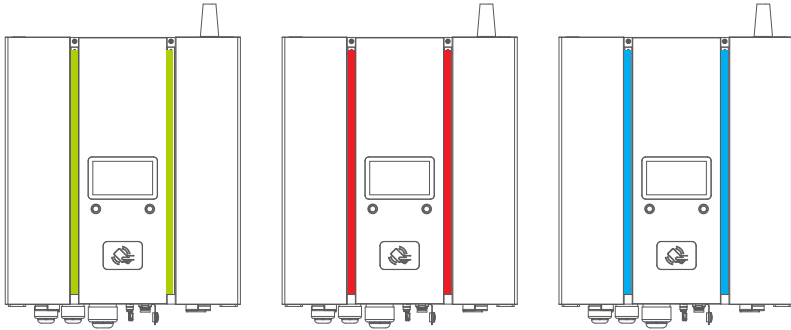

Status \ LED	Left Indicator	Right Indicator
Standby	Green	Green
Fault	Red	Red
Charging	Blue	Blue

2.3 Dimmensions

Main Size of Charger:

(Unit: mm)

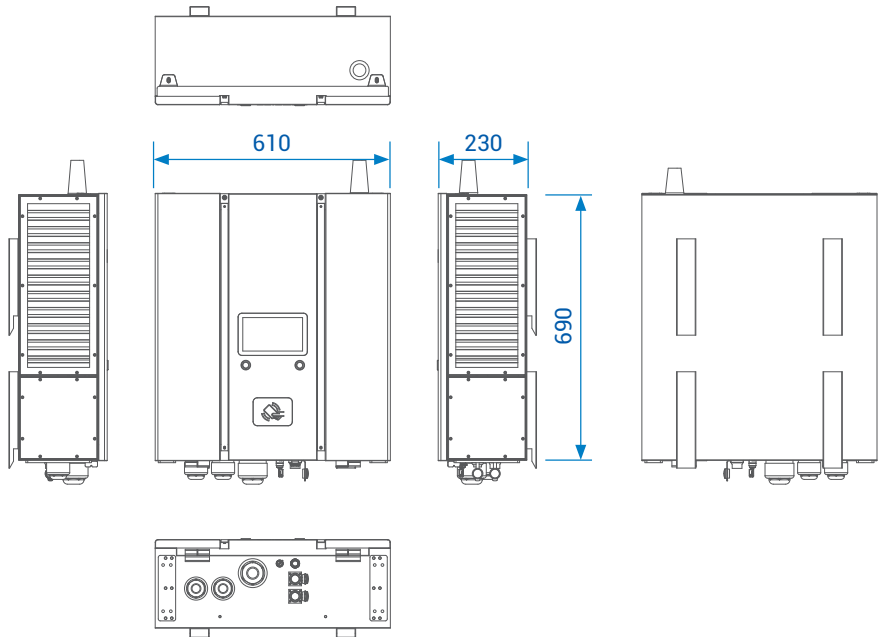

Wall-Mounted Bracket:

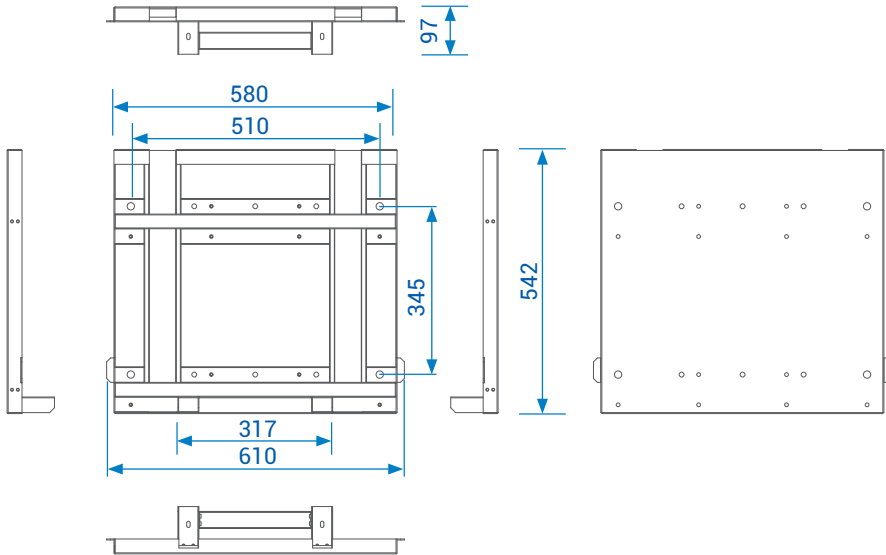

2.4 Direction of cooling Airflow

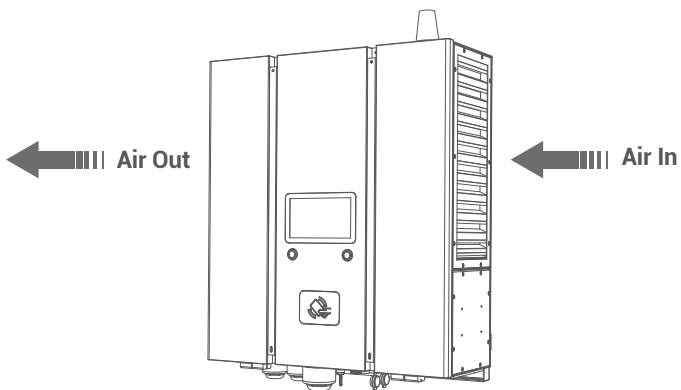

3. Installation Instruction

3.1 Before Installation

- Read all the instructions before using and installing this product.
- Do not use this product if power cable or charging cable have any damage.
- Do not use this product if the enclosure or charging connector are broken or open or if there is damage.
- Do not put any tool, material, finger or other body part into the charging connector or EV connector.



Warning: The product should be installed only by a licensed contractor and/or licensed technician in accordance with all building codes, electrical codes and safety standards.



Warning: The product should be inspected by a qualified installer prior to initial use. Under no circumstances will compliance with the information in this manual relieve user of his /her responsibilities to comply with all applicable codes and safety standards.

- Power feed must be 3 Phase Wye configuration with TN(-S)/TT grounding systems.
- In the installation of TN(-S) system: the neutral (N) and the PE of the power distribution are directly connected to the earth. The PE of the charger equipment is directly connected to the PE of power distribution and separate conductor for PE and neutral (N).
- In the installation of TT system: the neutral (N) and the PE of the power distribution are directly connected to the earth. The PE of the charger equipment is isolated to the PE of power distribution to the earth.
- The capacity of power supply should be higher than 33.0kVA in order to function correctly.
- The product should be installed in free air area and keep at least 30cm clearance distance to all air vent of the product.
- Need sufficient space for product installation and maintenance, please keep not less than 60cm clearance distance from all around the product.

**NOTICE**

It is recommended to conduct WI-Fi and 4G signal strength while charger installation. The RSSI (Received Signal Strength Indication) value is considered as good as higher than -65dBm. Poor connection quality might interrupt charging process or data transaction.

3.2 Grounding and Safety Requirement

- The product must be connected to a grounded, metal, permanent wiring system. Connections shall comply with all applicable electrical codes.
- Ensure no power is connected at all times when installing, servicing, or maintaining the charger.
- Use appropriate protection when connecting to main power distribution network.
- Use appropriate tools for each task.



CAUTION: The disconnect switch for each ungrounded conductor of AC input shall be provided by installation contractor or technician in accordance with the National Electric Code, ANSI/NFPA 70.



CAUTION: A cord extension set or second cable assembly shall not be used in addition to the cable assembly for connection of the EV to the EVSE.

3.2.1 Service Wiring

- Ground Connection

Always connect the Neutral at the service to Earth Ground. If ground is not provided by the electrical service then a grounding stake must be installed nearby. The grounding stake must be connected to the ground bar in the main breaker panel and Neutral connected to Ground at that point.

- 480Vac (Line to Line) Three-Phase

CAUTION!



This is feed from Wye-connection power grid, the Wall Mount DC Fast Charger can connect to L1, L2 or L3, and Neutral. Earth ground must be connected to neutral at only one point, usually at the breaker panel.

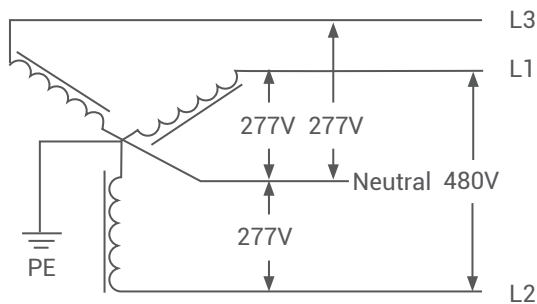

480V Three-Phase Wiring Connection



DANGERS

Be Aware of High Voltage!



WARNING!

Earth Connection is Essential!

3.3 Unpack the charger

- The product is Direct current (DC) charger, the packing design passed the packaging simulation test, if the packaging is damaged cause by overturning, falling or external impact during transportation, it may cause the product damage or defects. if there is any serious damage to the packaging when receiving the goods, please notify manufacturer (Electric Avenue) about your findings.
- Receiving the Watti Direct DC 30KW Wall Mount. The product is delivered by a transport company to a warehouse or specified location where it will be handed over. Transporting the DC 30KW Wall Mount to its final location (last mile service) is not standard included in the order.
- NOTICE: The delivery truck unloads the pallet carrying the DC 30KW Wall Mount. The movement of the 30KW Wall Mount to its final location is the responsibility of the customer / contractor.
- Checking the TiltWatch sensors: If the TiltWatch indicator is tilted over 80°
- 1. Do not refuse the delivery / receipt.
- 2. Make a notation on the delivery receipt and inspect cabinet for damage.
- 3. If damage is discovered, leave cabinet in original package and request immediate inspection from carrier within 3 days of delivery.
- 4. Contact manufacturer (Electric Avenue) by email at support@goelectricave.com to notify us about your findings.



WARNING!

Charger weight might >80Kg!
Be careful during unpack process.

STEP 1.

Remove the surrounding boards

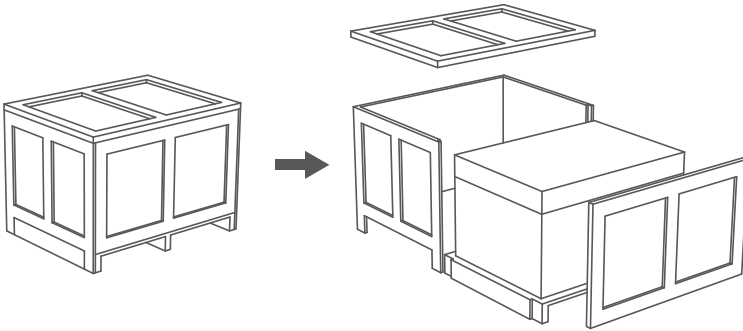

STEP 2.

Remove the packaging film and the paper cover. Accessories (wall mount) are packed in a carton.

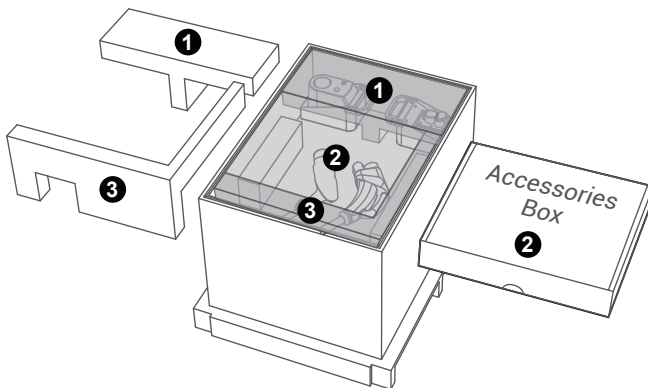

STEP 3.

Remove the surrounding cardboard and film. Take out the Charger and Gun holders.

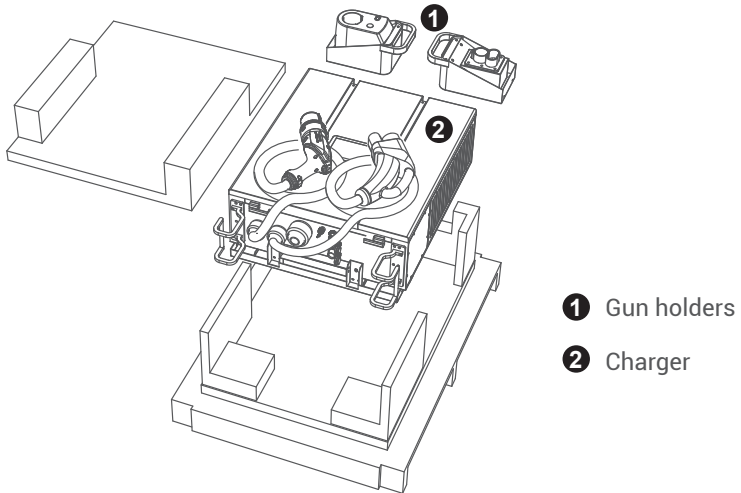

Accessories Box

- 1 Accessories
- 2 Wall mount

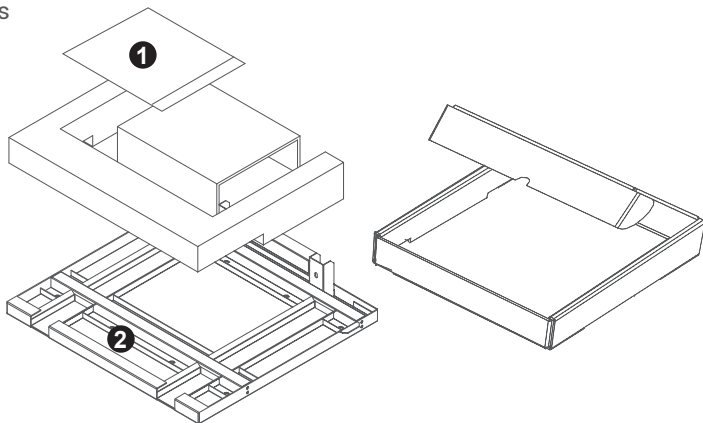

3.4 Recommended Tools for Installation and Inspection

3.4.1 Recommended Tools for Installation

Type	Description
Philips Screwdriver	No. 2 and 3
Shifting Wrench	8" (24mm)
Ball-Head Hex Key	2.5mm and 5mm
Socket Screwdriver	No. 8, 10 and 17
Electrical Tape	Black / 15mm Width
AC Input Cable	AWG#4 (21.15mm ²) Cable x 5 (L1, L2, L3, N, PE)
Ring Terminal	1. AWG#4 x 5 (L1, L2, L3, N, PE) 2. Ring Terminal inner diameter is 6.4mm; outer diameter is 16.5mm for L1, L2, L3 and N 3. Ring Terminal inside diameter is 5.3mm; outer diameter is 12mm for PE
Crimping Pliers for Ring Terminal	
Machine Drill	
Level Ruler	

3.4.2 Recommended Tools for Inspection & Commissioning

Type	Description
EV or EV Simulator	Meet CHAdeMO/CCS1 standard
Multiple Meter	1000V
Current Probe	100Amp
RFID Authorized Card	
RFID No Valid Card	
Door Key	
Laptop or PC & CAT6 cable	For Charger Configuration
Wi-Fi /4G signal quality checker	Recommended

3.5 Installation Procedure

STEP 1.

Place the wall-mounted bracket between 600mm (24 inches) and 1.2m (4 feet) above the floor, and then attach 4 pcs 3/8" expansion screws to the wall-mounted bracket. (Unit: mm)

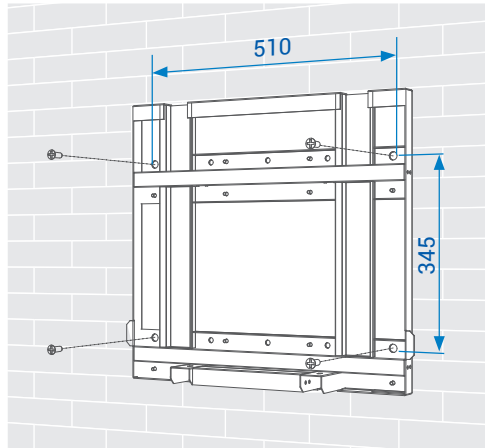

Unit: mm

STEP 2.

Install the four tenons on the rear side of the charger into the grooves on the wall-mounted bracket.

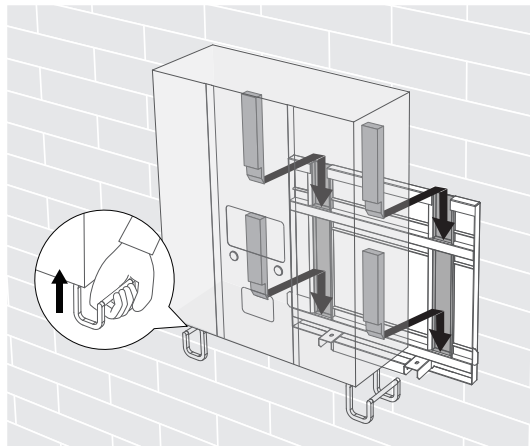

STEP 3.

Screw 2 sets M6 screws to the bottom of the charger to fix the charger on the bracket.

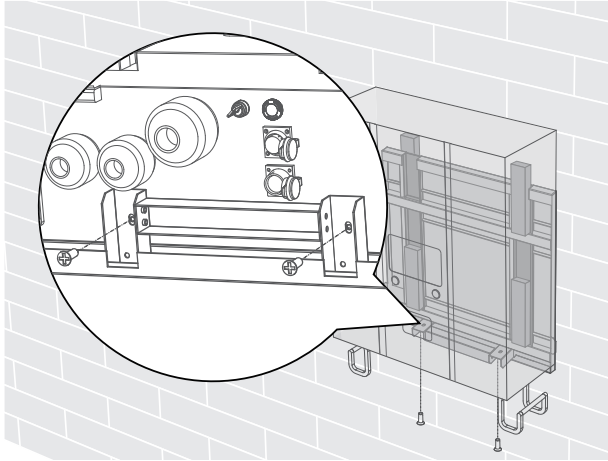

STEP 4.

Keep the hook-shape holders as cable holder or disassemble them if not necessary.

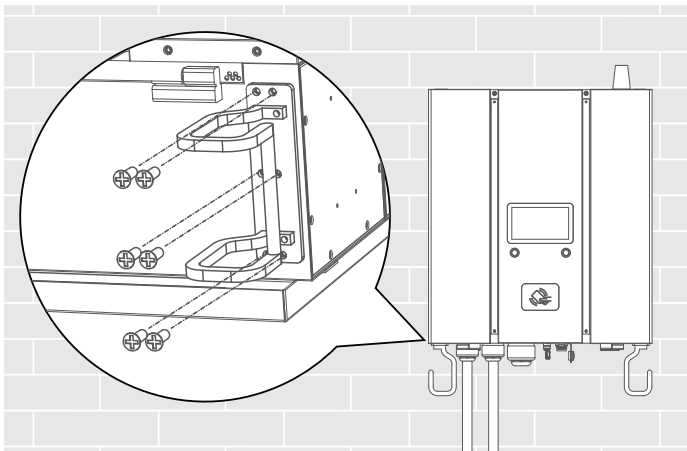

Installing the Gun Holder

STEP 1.

Four screws of the Gun Holder must be disassembled at the circles below outlined.

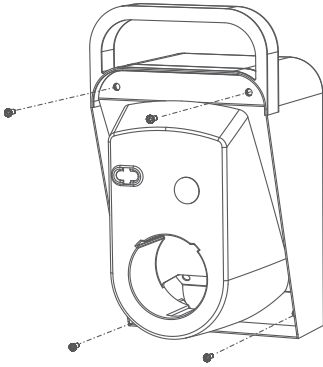

Gun Holder screw location

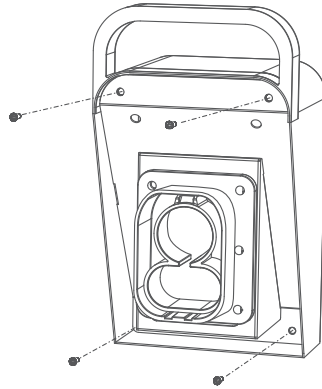

Gun Holder screw location

STEP 2.

Remove the Gun Holder cover and place Gun Holder base at the appropriate height between 600mm (24 inches) and 1.2m (4 feet), and then attach 4 pcs 5/16" expansion screws to the Gun Holder base, then assembly the cover back.

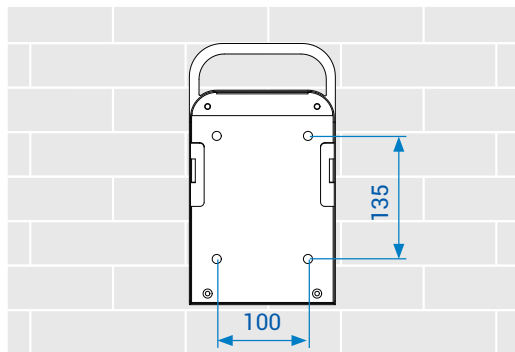

The hole position of the Gun Holder
Unit: mm

Installing Cables

STEP 1.

Remove 2 of M5 screws and push the button (marked as no.3) to open front cover :

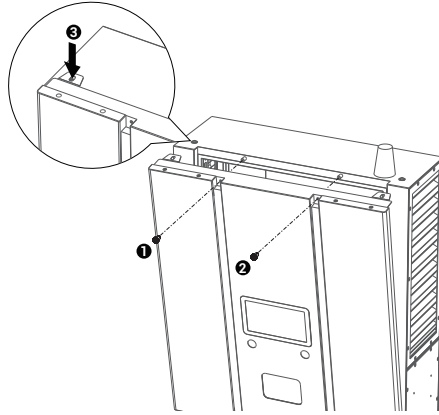

STEP 2.

Please use XLPE power cables or equivalent for AC input connection, power cable outer diameter is between 32 and 40mm. If XLPE cable is not available, please use conduit hub and conduit size M50 to prevent electrical hazards and do best water proof. the requirements of conduit shall be according to EN61386-24 or followed local laws and regulations.

Each wire shall be crimped with the corresponding terminal before feeding. L1, L2, L3 and N shall chose terminals with inner diameter 6.4mm and outer diameter 16.5mm, PE shall chose terminals with inner diameter 5.3mm and outer diameter 12mm. And then feeding the cable from bottom side and passing through the cable gland.

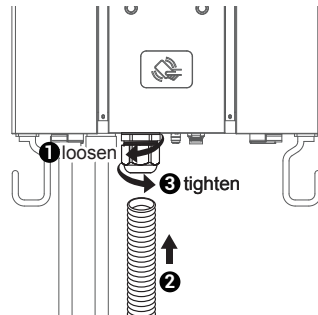
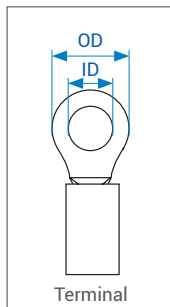
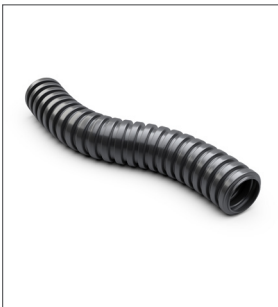

STEP 3.

Fasten L1, L2, L3 and N wires onto the 4P terminal with M6 screws, torque force: 30Kgf.cm/5-15 secs. Fasten PE wire to the busbar with M5 screw, torque force: 27Kgf.cm/5-15 secs. Keep proper length of each wires then fasten cable grand.

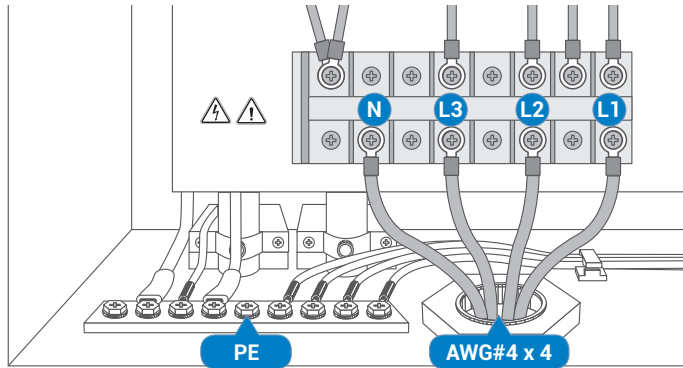
**STEP 4.**

Fasten L1, L2, L3 and N to an external beaker. Recommended breaker spec.: rated current shall be 50A, B Curve type; with max. Residual leakage current (RCD) shall be 30mA, type A.

STEP 5.

Turn on the power source and operation screen will be ready within 30 seconds.



Not following installation instruction will cause charger damage.



A 50A NFB with 30mA RCD-Type A is recommended.

3.6 Installation Inspection & Commissioning

3.6.1 Environmental Check

Item	Status	Remark
Ambient Temperature		
Ambient Humidity		
Sunshade		Recommended but not required.
Rain Canopy		Recommended but not required.
Air Circulation / Drafty		
Dust Level		
Anti-Vandalism Measures		

3.6.2 External Infrastructure Readiness & Check

Item	Status	Remark
Input Wirings & Terminals		Type/ Length/ Cross Section
Key & Lock of Cabinet Door		
Fixing Screws		Type / No
No Fuse Breaker (NFB)		Notice: Current rating of NFB shall be higher than 50 Amp
Residual Current Device (RCD)		Notice: Maximum RCD residual current shall not exceed 30mA
Input Electricity Capacity		
Input Electricity Configuration		Wye
Grounding Resistance		<50Ω
Grounding System		
Input Voltage & Frequency		
Network Connection & Quality		Wi-Fi , 4G > -65dBm

3.6.3 EVSE Check – Static (Non-Powered)

Item	Status	Remark
Outlook		
Labeling & Warning Signs		
Package (Accessory) List		
Robustness of Input Wirings		

3.6.4 EVSE Check - Power On

Item	Status	Remark
Screen On		
Acoustic Noise		
Screen Display & Function		
Time Display Correctly		
Network Connection Quality		
Cooling Fans Operation & Noise		
Led Status Indication		
EVSE Setting		
Function of Engineer Mode		
Version of H.W. & F.W.		
Remote Control & Monitoring		
Backend Server Connection		
Network Connection & Quality		Wi-Fi , 4G > -65dBm

3.6.5 EVSE Check - Charging

Item	Status	Remark
User Authorization –RFID		
User Authorization –QR Code		
User Authorization –Others.		
Waiting Time of Connection Check		
Reading of Each Display Item		
Full Charge Test		
Function of Electronic Lock		
Reading of Engineer Mode		
Airflow & Noise of Cooling Fan		
Charging Record (log) Upload		
Remote Control & Monitoring		

3.6.6 EVSE Check –System Power Button

Item	Status	Remark
Emergency Stop Button		

4. Network Setting

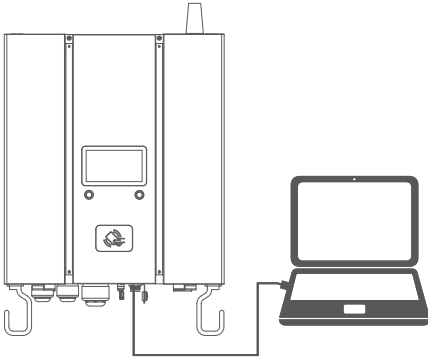

Use the following IP address:

IP address:

Subnet mask:

Default gateway: . .

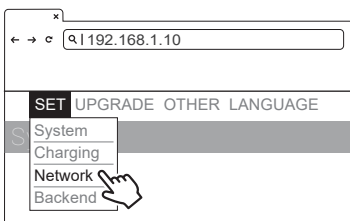
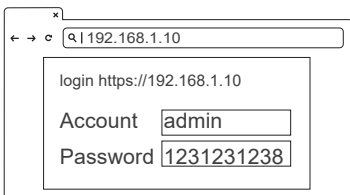

4.1 Wi-Fi Network Setting

- Laptop with RJ45 interface.
- Connect RJ45 cable from Laptop to charger's RJ45 port.
- Setup parameters in the Webservice.

Step 1.

Before opening web browser, please enter network setting to set your IPV4 static IP to 192.168.1.1 in PC

Step 2.

Open web service browser, type the IP address of charger "192.168.1.10" into the URL bar to access the web page of charger.

- Account: admin
- Password: 1231231238

Step 3.

SET -> Network.

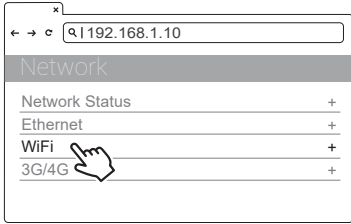

Step 4.

Select Wi-Fi Module

Select Wi-Fi modes and fill in SSID and Password according to your application, if not required, just keep default.

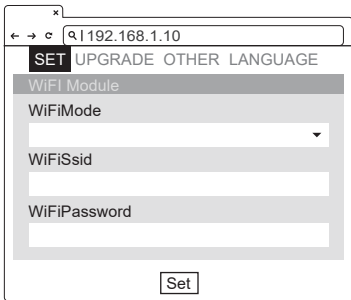

Wi-Fi Setting	Description
Wifi Ssid	Service Set Identifier · SSID
Wifi Password	Password to access to Wi-Fi
Wifi Dhcp Server	DHCP server of Wi-Fi
Wifi Dhcp Client	DHCP client of Wi-Fi
WifiIpAddress	Wi-Fi IP address
WifiSubmask Address	Wi-Fi submask address
WifiGateway Address	Wi-Fi gateway address

4.2 3G/4G Setting

4.2.1 SIM Card Installation

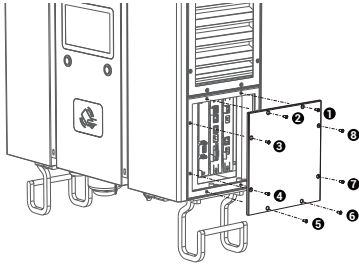

Step 1.

Loosen 8pcs of M4 screws to open the door in the right hand side.

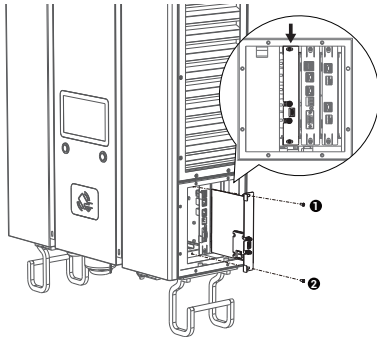

Step 2.

Loosen screws and take out the tray in the left hand side, you can find the 4G/Wi-Fi module.

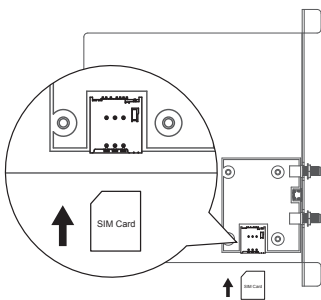

Step 3.

Insert 3G/4G Micro SIM Card in the tray, ensure the gold contacts are facing down and the notch is located in the upper left corner. Note the tray might be damaged if insert SIM card in wrong direction.

Step 4.

Reinstall the tray and side door, ensure the side door is well fixed at original position which considering water and dust resistant.

4.2.2 Setting and Enable 3G/4G Module.

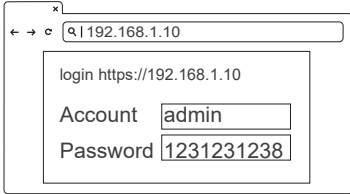

Step 1.

- Please contact your SIM provider to get the APN, PPP ID and password.
*Note: PPP ID and password maybe options depend on your SIM provider.
- Open the web page of charger and sign-in.

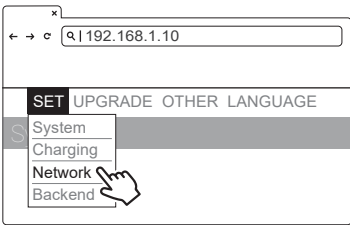

Step 2.

SET -> Network.

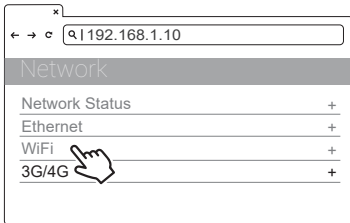

Step 3.

- Network -> 3G/4G Module to fill corresponding information into TelcomApn, TelcomChapPapId and TelcomChapPapPwd.
- Press "Set" to save those information. Then 3G/4G will be activated in few minutes.

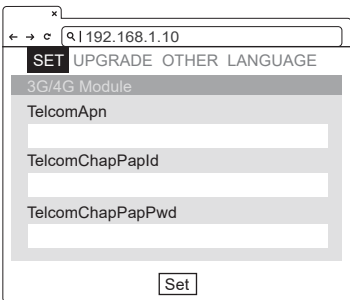

TelcomApn	APN Setting
TelcomChapPapId	Login ID authentication
TelcomChapPapPwd	Login password authentication
TelcomIpAddress	IP address

4.3 Time setting

Automatic setting : The time will be adjusted automatically when the charger connects to internet.

Time server :

- time.windows.com
- cn.ntp.org.cn
- tock.stdtime.gov.tw

Note: Firewall and network environment may influence the time server connection

Manual setting :

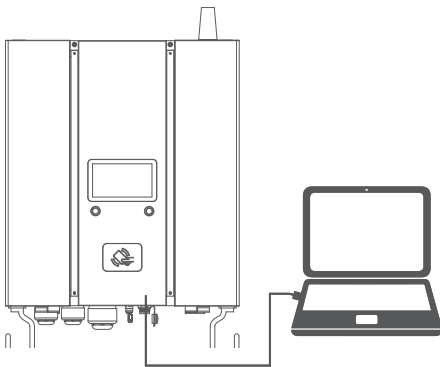

Step 1.

- Laptop with RJ45 interface.
- Connect RJ45 cable from Laptop to charger's RJ45 port.
- Setup parameters in the Webservice.

Use the following IP address:

IP address:

Subnet mask:

Default gateway:

Step 2.

Before opening web browser, please enter network setting to set your IPV4 static IP to 192.168.1.1 in PC

Step 3.

Open web service browser, type the IP address of charger "192.168.1.10" into the URL bar to access the web page of charger.

- Account: admin
- Password: 1231231238

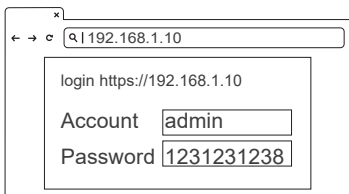

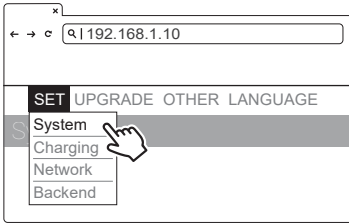

Step 4.

SET -> Network.

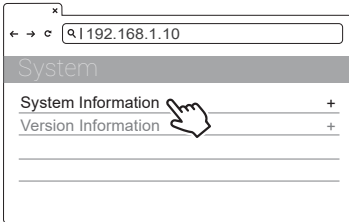

Step 5.

Click "System information".

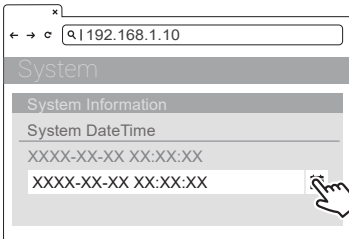

Step 6.

Click system date time.

Click the calendar button on the right to set the current time.

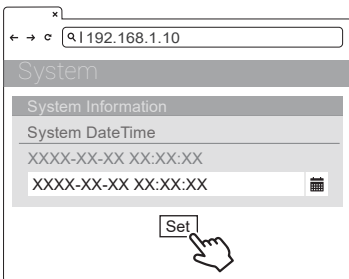

Step 7.

After the setting is completed, click SET and wait until the setting completion window appears.

5. Operation Process

5.1 Operating Sequence

- System Initialization
- User Authorization
- Plug in DC Charging Connector
- Preparing for Charging
- In Charging
- Charging Terminated
- Alarm Messages
- Status Messages

5.2 Operating Procedure

5.2.1 System Initialization

- When the charger is powered on, it start with the “Charging Station” Initializing page.
- You will see the below image on the screen after powering on and the system is initializing.
- The initializing process will take around 2 minutes, then shows home page.

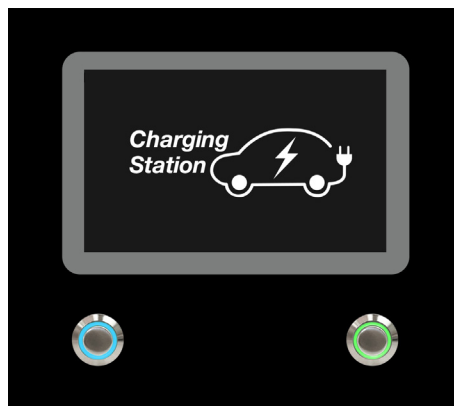

Initializing page



Home page

Unit and currency if billing function is enabled

• Ethernet Backend Status



• Wi-Fi Status



• 3G/4G Status



• OCPP Backend Status



5.2.2 User Authorization

- After the system is initialized the screen will stay at Home page as below illustrated.
- Use your RFID card or mobile app to authorize the use of the EVSE.



Home page

User authorization Method: RFID, QR code and mobile APP.

- Unauthorized method(s) will be darker on the screen if the method is disable.

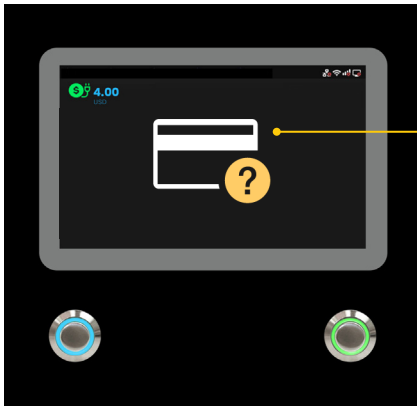

User authorizing



User authorized.



Authorization failed

5.2.3 Plug in Charging Connector

- After authorization the screen will ask the user to plug the charging connector into the EV charging inlet as below illustrated.
- Take the Charging connector from the charging cable holder and plug the connector into EV charging inlet. The charger will automatically detect the type of the charging connector.
- It will normally take less than 10 seconds to start the process after completing the physical connection of charging connector to charging inlet. To terminate this session, please press the left button to return to the Home page

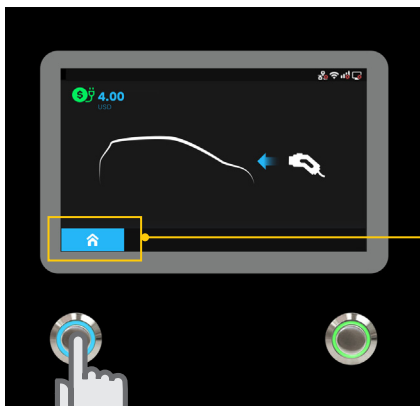

Press left button to terminate this charging session and then return to Home page.

Plug-in page



The left connector will always have the charging priority when plug in 2 connectors simultaneously.

5.2.4 Prepare for Charging

- After authorization and plug-in process, the charger will start communicating with the vehicle and the screen will show the Preparing page as below illustrated.

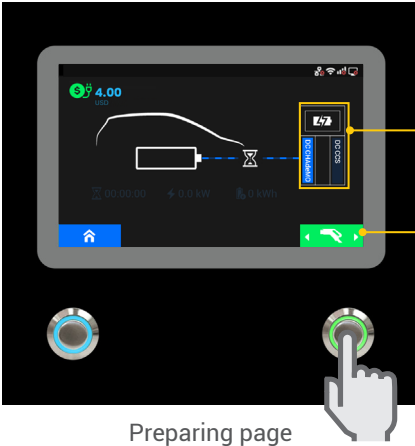

Information of Selected Charging Connector

Connector Select Button

Press right button to select the charger connector that the user would like to use.

Preparing page

5.2.5 In Charging

- The screen will show the Charging Page as below illustrated once the charger goes into the ready to charge stage.

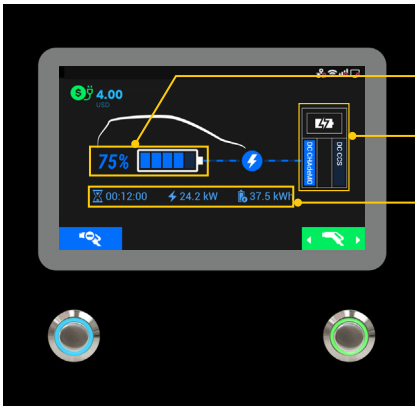

EV battery SOC

Show the selected connector in use

Charging information area

 Charging duration,

 Charged power

 Energy

Charging page

- To start charging, load the charging information. When the battery has been fully charged or reaches the limit of the setting it will stop charging automatically and go to the next process.

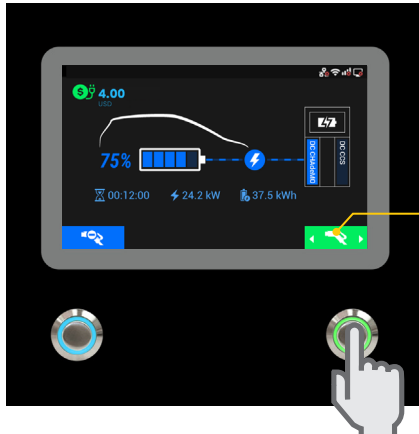

Press right button to select the charger connector that the user would like to stop.

- User also can tap the RFID to stop charging.
- Charging system only accept one gun to charging. Please don't plug the other connector during charging. The two guns can't be charged together.

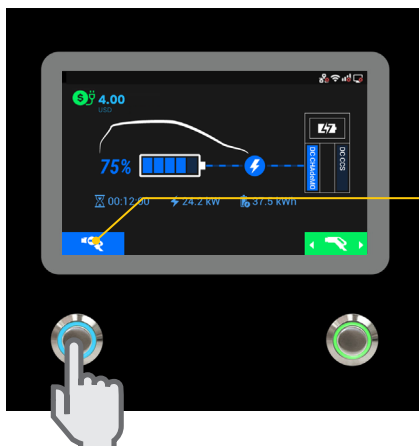

Tap RFID card or push stop button to stop

5.2.6 Charging Terminated



- After charging is terminated the charger system will show the Charging Summary page as below illustrated and the charging connector will automatically unlock.
- Unplug the charging connector from charging inlet of the EV and return the charging connector to charging cable holder.
- The screen will go back to the Home Page or the other charging connector's Charging Page if unplugged from the charging connector.
- During simultaneous charging the screen will go to the other charging connector's Charging Page if either charging connector is unplugged.

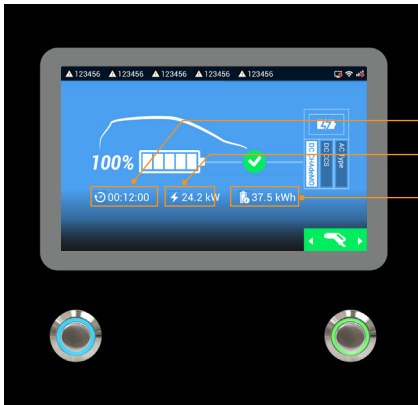

- Charging duration
- Charging power
- Charging energy

Charging summary page

5.2.7 Status Messages

- When problems occur with this charger or the charging process a status code will display on screen as below illustrated. Please follow the troubleshooting table to solve the problem.

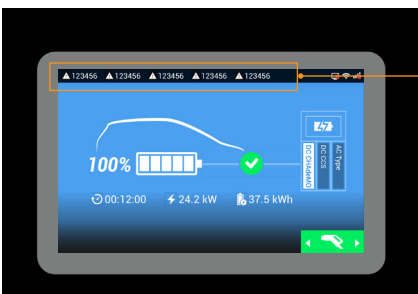

- Status Code

5.3 Troubleshooting

- Please follow the instruction in the table when errors occur during the charging process.
- Or please connect the EVSE to the Internet and then contact the EVSE provider for further instructions.
- Please provide the EVSE information including serial number, model name, status code, failure behavior and timing, and also connect the EVSE to the Internet before remote diagnostics and upgrading
- If an emergency occurs push the Emergency Stop Button to stop charging immediately.

5.4 Status Codes

(V0.33)

Status Code	Description
011001	CHAdEMO output fuse blew
011002	CCS output fuse blew
011003	GB output fuse blew
011004	RCD/CCID self-test fail
011005	AC input contactor 1 welding
011006	AC input contactor 1 driving fault
011007	AC input contactor 2 welding
011008	AC input contactor 2 driving fault
011009	AC output relay welding
011010	AC output relay driving fault
011011	CHAdEMO output relay welding
011012	CHAdEMO output relay driving fault
011013	CCS output relay welding
011014	CCS output relay driving fault
011015	GB output relay welding
011016	GB output relay driving fault
011017	AC connector temperature sensor broken
011018	CHAdEMO connector temperature sensor broken
011019	CCS connector temperature sensor broken
011020	GB connector temperature sensor broken

Status Code	Description
011021	WiFi module broken
011022	3G/4G module broken
011023	Aux. power module broken
011024	Relay control module /smart box broken
011025	CHAdEMO connector lock fail
011026	GB connector lock fail
011027	AC connector lock fail
011028	CHAdEMO module broken
011029	CCS module broken
011030	GBT module broken
011031	PSU module broken
011032	RCD/CCID module broken
011033	Maximum Output Current setup error
011034	Shutter fault
011035	Ble module broken
011036	Rotary switch fault
011037	CCS liquid chiller water level fault
011038	Reserved
011039	Reserved
011040	Reserved
012200	System L1 input OVP
012201	System L2 input OVP
012202	System L3 input OVP
012203	System L1 input UVP
012204	System L2 input UVP
012205	System L3 input UVP
012206	PSU L1 input OVP
012207	PSU L2 input OVP
012208	PSU L3 input OVP
012209	PSU L1 input UVP
012210	PSU L2 input UVP
012211	PSU L3 input UVP

Status Code	Description
012212	System L1 input drop
012213	System L2 input drop
012214	System L3 input drop
012215	System AC output OVP
012216	System AC L1 output OCP
012217	System CHAdeMO output OVP
012218	System CHAdeMO output OCP
012219	System CCS output OVP
012220	System CCS output OCP
012221	System GB output OVP
012222	System GB output OCP
012223	System ambient/inlet OTP
012224	System critical point OTP
012225	PSU ambient/inlet OTP
012226	PSU critical point OTP
012227	Aux. power module OTP
012228	Relay board/smart box OTP
012229	CHAdeMO connector OTP
012230	CCS connector OTP
012231	GB connector OTP
012232	AC connector OTP
012233	RCD/CCID trip
012234	CHAdeMO GFD trip
012235	CCS GFD trip
012236	GB GFD trip
012237	SPD trip
012238	Main power breaker trip
012239	Aux. power breaker trip
012240	PSU communication fail
012241	WiFi module communication fail
012242	3G/4G module communication fail
012243	RFID module communication fail

Status Code	Description
012244	Bluetooth module communication fail
012245	LCM module communication fail
012246	Aux. power module communication fail
012247	Relay control board/smart box communication fail
012248	CCS module communication fail
012249	CHAdEMO module communication fail
012250	GBT module communication fail
012251	Emergency stop
012252	Door open
012253	System fan decay
012254	Fail to create share memory
012255	CSU initialization failed
012256	AC Ground Fault
012257	MCU self-test Fault
012258	Relay self-test Fault
012259	CHAdEMO groundfault detection timeout (GFD)
012260	CCS groundfault detection timeout (GFD)
012261	GB groundfault detection timeout (GFD)
012262	System AC L1 output Circuit Short
012263	PSU Duplicate ID
012264	PSU Output Short Circuit
012265	PSU Discharge Abnormal
012266	PSU Dc Side ShutDown
012267	PSU Failure Alarm
012268	PSU Protection Alarm
012269	PSU FanFailure Alarm
012270	PSU Input UVP
012271	PSU Input OVP
012272	PSU WalkIn State
012273	PSU Power Limited State
012274	PSU Id Repeat
012275	PSU Severe Uneven Current

Status Code	Description
012276	PSU Three Phase Input Inadequate
012277	PSU Three Phase Onput Imbalance
012278	PSU Ffc Side ShutDown
012279	NO PSU Resource
012280	Self test Failed due to communication of Relayboard failure
012281	Self test Failed due to communication of Fanboard failure
012282	Self test Failed due to communication of Primary failure
012283	Self test Failed due to communication of Chademoboard failure
012284	Self test Failed due to communication of CCSboard failure
012285	Self test Failed due to AC Contact failure
012286	Self test Failed due to communication of PSU failure
012287	Self test Failed due to Model name is none match
012288	CCS output UVP
012289	Chademo output UVP
012290	GBT output UVP
012291	Self test Failed due to communication of GBTboard failure
012292	Self test Failed due to communication of AC failure
012293	Self test Failed due to communication of Ledboard failure
012294	AC input ovp
012295	AC input uvp
012296	CHAdEMO groundfault detection - warning
012297	CCS groundfault detection - warning
012298	GB groundfault detection - warning
012299	System AC L2 output OCP
012300	System AC L3 output OCP
012301	System AC L2 output Circuit Short
012302	System AC L3 output Circuit Short
012303	CCS liquid chiller water level warning
012304	disconnected from power cabinet
012305	Meter communication timeout
012306	The dip switch of the PSU may be incorrect

Status Code	Description
012307	Psu Fuse Burn-Out
012308	Psu Pfc And Dcdc Communication Fault
012309	Psu Bus Voltage Unbalance
012310	Psu Bus Over Voltage
012311	Psu Bus Voltage Abnormal
012312	Psu Bus Under Voltage
012313	Psu Input Phase Loss
012314	Psu Fan Full Speed
012315	Psu Temperature Power Limit
012316	Psu Ac Power Limit
012317	Psu Dcdc Eeprom Fault
012318	Psu Pfc Eeprom Fault
012319	Psu Dcdc Over Voltage
012320	Reserved
012321	Reserved
012322	Reserved
012323	Reserved
012324	Reserved
012325	Reserved
012326	Reserved
012327	Reserved
013600	Normal stop charging by user
013601	Charging Time's up
013602	Replace system air filter
013603	Reach to CHAdeMO max. plugging times.
013604	Reach to CCS max. plugging times.
013605	Reach to GB max. plugging times.
013606	Reach to AC max. plugging times.
013607	CSU fimrware update fail
013608	CHAdeMO Module fimrware update fail
013609	CCS Module fimrware update fail
013610	GB Module fimrware update fail

Status Code	Description
013611	Aux. power module firmware update fail
013612	Relay control module firmware update fail
013613	LCM module firmware update fail
013614	Bluetooth module firmware update fail
013615	WiFi module firmware update fail
013616	3G/4G module firmware update fail
013617	SMR firmware update fail
013618	RFID module firmware update fail
013619	configured by USB flash drive
013620	configured by backend
013621	configured by webpage
013622	disconnected from Internet through Ethernet
013623	disconnected from Internet through WiFi
013624	disconnected from Internet through 3G/4G
013625	disconnected from AP through WiFi
013626	disconnected from APN through 3G/4G
013627	WiFi disabled (separated charger only)
013628	4G disabled (separated charger only)
013629	Reserved
013630	Reserved
013631	Reserved
023700	CHAdeMO EV communication Fail
023701	CCS EV communication Fail
023702	GB EV communication Fail
023703	AC: pilot fault
023704	CHAdeMO: battery malfunction
023705	CHAdeMO: no charging permission
023706	CHAdeMO: battery incompatibility
023707	CHAdeMO: battery OVP
023708	CHAdeMO: battery UVP
023709	CHAdeMO: battery OTP
023710	CHAdeMO: battery current difference

Status Code	Description
023711	CHAdEMO: battery voltage difference
023712	CHAdEMO: shift position
023713	CHAdEMO: battery other fault
023714	CHAdEMO: charging system error
023715	CHAdEMO: ev normal stop
023716	CHAdEMO: connector temperature sensor broken
023717	CHAdEMO: connector lock fail
023718	CHAdEMO: d1 on no receive
023719	CHAdEMO: bms k to j on timeout
023720	CHAdEMO: bms charge allow timeout
023721	CHAdEMO: wait groundfault timeout
023722	CHAdEMO: bms ev relay on timeout
023723	CHAdEMO: bms req current timeout
023724	CHAdEMO: bms k to j off timeout
023725	CHAdEMO: bms ev relay off timeout
023726	CHAdEMO: adc more than 10v
023727	CHAdEMO: adc more than 20v
023728	CHAdEMO: bms charge before stop
023729	CHAdEMO: charger get normal stop cmd
023730	CHAdEMO: charger get emergency stop cmd
023731	CHAdEMO: isolation result fail
023732	CHAdEMO: mother board miss link
023733	CHAdEMO: output voltage more than limit
023734	CHAdEMO: req current more than limit
023735	CHAdEMO: re capability bms eqr current exceed
023736	CHAdEMO: charge remaining count done
023737	CCS_EVCC_EVErrorCode_FAILED_RESSTemperatureInhibit
023738	CCS_EVCC_EVErrorCode_FAILED_EVShiftPosition
023739	CCS_EVCC_EVErrorCode_FAILED_ChargerConnectorLockFault
023740	CCS_EVCC_EVErrorCode_FAILED_EVRESSMalfunction
023741	CCS_EVCC_EVErrorCode_FAILED_ChargingCurrentdifferential
023742	CCS_EVCC_EVErrorCode_FAILED_ChargingVoltageOutOfRange

Status Code	Description
023743	CCS_EVCC_EVErrorCode_FAILED_ChargingSystemIncompatibility
023744	CCS_EVCC_EVErrorCode_FAILED_EmergencyEvent
023745	CCS_EVCC_EVErrorCode_FAILED_Breaker
023746	CCS_EVCC_EVErrorCode_FAILED_NoData
023747	CCS_EVCC_EVErrorCode_FAILED_reserved_by_DIN_A
023748	CCS_EVCC_EVErrorCode_FAILED_reserved_by_DIN_B
023749	CCS_EVCC_EVErrorCode_FAILED_reserved_by_DIN_C
023750	CCS_EVCC_EVErrorCode_FAILED_reserved_by_ISO_1
023751	CCS_EVCC_EVErrorCode_FAILED_reserved_by_ISO_2
023752	CCS_EVCC_EVErrorCode_FAILED_reserved_by_ISO_3
023753	CCS_EVCC_EVErrorCode_FAILED_reserved_by_OEM_1
023754	CCS_EVCC_EVErrorCode_FAILED_reserved_by_OEM_2
023755	CCS_EVCC_EVErrorCode_FAILED_reserved_by_OEM_3
023756	CCS_EVCC_EVErrorCode_FAILED_reserved_by_OEM_4
023757	CCS_EVCC_EVErrorCode_FAILED_reserved_by_OEM_5
023758	CCS_SECC_ResponseCode_FAILED_SequenceError
023759	CCS_SECC_ResponseCode_FAILED_SignatureError
023760	CCS_SECC_ResponseCode_FAILED_UnknownSession
023761	CCS_SECC_ResponseCode_FAILED_ServiceIDInvalid
023762	CCS_SECC_ResponseCode_FAILED_Payment SelectionInvalid
023763	CCS_SECC_ResponseCode_FAILED_IdentificationSelectionInvalid
023764	CCS_SECC_ResponseCode_FAILED_ServiceSelectionInvalid
023765	CCS_SECC_ResponseCode_FAILED_CertificateExpired
023766	CCS_SECC_ResponseCode_FAILED_CertificateNotYetValid
023767	CCS_SECC_ResponseCode_FAILED_CertificateRevoked
023768	CCS_SECC_ResponseCode_FAILED_NoCertificateAvailable
023769	CCS_SECC_ResponseCode_FAILED_CertChainError
023770	CCS_SECC_ResponseCode_FAILED_CertValidationError
023771	CCS_SECC_ResponseCode_FAILED_CertVerificationError
023772	CCS_SECC_ResponseCode_FAILED_ContractCanceled
023773	CCS_SECC_ResponseCode_FAILED_ChallengeInvalid
023774	CCS_SECC_ResponseCode_FAILED_WrongEnergyTransferMode

Status Code	Description
023775	CCS_SECC_ResponseCode_FAILED_WrongChargeParameter
023776	CCS_SECC_ResponseCode_FAILED_ChargingProfileInvalid
023777	CCS_SECC_ResponseCode_FAILED_TariffSelectionInvalid
023778	CCS_SECC_ResponseCode_FAILED_EVSEPresentVoltageTooLow
023779	CCS_SECC_ResponseCode_FAILED_PowerDeliveryNotApplied
023780	CCS_SECC_ResponseCode_FAILED_MeteringSignatureNotValid
023781	CCS_SECC_ResponseCode_FAILED_NoChargeServiceSelected
023782	CCS_SECC_ResponseCode_FAILED_ContactorError
023783	CCS_SECC_ResponseCode_FAILED_CertificateNotAllowedAtThisEVSE
023784	CCS_SECC_ResponseCode_FAILED_GAChargeStop
023785	CCS_SECC_ResponseCode_FAILED_AlignmentError
023786	CCS_SECC_ResponseCode_FAILED_ACDError
023787	CCS_SECC_ResponseCode_FAILED_AssociationError
023788	CCS_SECC_ResponseCode_FAILED_EVSEChargeAbort
023789	CCS_SECC_ResponseCode_FAILED_NoSupportedApp-Protocol
023790	CCS_SECC_ResponseCode_FAILED_ContractNotAccepted
023791	CCS_SECC_ResponseCode_FAILED_MOUnknown
023792	CCS_SECC_ResponseCode_FAILED_OEM_Prov_CertificateRevoke
023793	CCS_SECC_ResponseCode_FAILED_OEM_SubCA1_CertificateRevoked
023794	CCS_SECC_ResponseCode_FAILED_OEM_SubCA2_CertificateRevoked
023795	CCS_SECC_ResponseCode_FAILED_OEM_RootCA_CertificateRevoked
023796	CCS_SECC_ResponseCode_FAILED_MO_Prov_CertificateRevoked
023797	CCS_SECC_ResponseCode_FAILED_MO_SubCA1_CertificateRevoked
023798	CCS_SECC_ResponseCode_FAILED_MO_SubCA2_CertificateRevoked
023799	CCS_SECC_ResponseCode_FAILED_MO_RootCA_CertificateRevoked
023800	CCS_SECC_ResponseCode_FAILED_CPS_Prov_CertificateRevoked

Status Code	Description
023801	CCS_SECC_ResponseCode_FAILED_CPS_SubCA1_CertificateRevoked
023802	CCS_SECC_ResponseCode_FAILED_CPS_SubCA2_CertificateRevoked
023803	CCS_SECC_ResponseCode_FAILED_CPS_RootCA_CertificateRevoked
023804	CCS_SECC_ResponseCode_FAILED_reserved_1
023805	CCS_SECC_ResponseCode_FAILED_reserved_2
023806	CCS_SECC_ResponseCode_FAILED_reserved_3
023807	CCS_SECC_ResponseCode_FAILED_reserved_4
023808	CCS_SECC_ResponseCode_FAILED_reserved_5
023809	CCS_SECC_TIMEOUT_SLAC_TT_EVSE_SLAC_init
023810	CCS_SECC_TIMEOUT_SLAC_TP_match_response
023811	CCS_SECC_TIMEOUT_CM_START_ATTEN_CHAR_IND
023812	CCS_SECC_TIMEOUT_SLAC_TT_EVSE_match_MNBC
023813	CCS_SECC_TIMEOUT_SLAC_TP_EVSE_avg_atten_calc
023814	CCS_SECC_TIMEOUT_SLAC_CM_ATTEN_CHAR_RSP
023815	CCS_SECC_TIMEOUT_SLAC_CM_VALIDATE_REQ_1ST_CM_SLAC_MATCH_REQ
023816	CCS_SECC_TIMEOUT_SLAC_TT_EVSE_assoc_session
023817	CCS_SECC_TIMEOUT_SLAC_TT_EVSE_vald_toggle
023818	CCS_SECC_TIMEOUT_SLAC_CM_MNBC_SOUND_IND
023819	CCS_SECC_TIMEOUT_SLAC_CM_VALIDATE_REQ_2ND_CM_SLAC_MATCH_REQ
023820	CCS_SECC_TIMEOUT_SLAC_reserved_3
023821	CCS_SECC_TIMEOUT_SLAC_reserved_4
023822	CCS_SECC_TIMEOUT_SLAC_reserved_5
023823	CCS_SECC_TIMEOUT_SLACC_SDP_UDP_TT_match_join
023824	CCS_SECC_TIMEOUT_SLACC_SDP_TCP_TT_match_join
023825	CCS_SECC_TIMEOUT_SLACC_SDP_TP_amp_map_exchange
023826	CCS_SECC_TIMEOUT_SLACC_SDP_TP_link_ready_notification
023827	CCS_SECC_TIMEOUT_SLACC_SDP_reserved_1
023828	CCS_SECC_TIMEOUT_SLACC_SDP_reserved_2

Status Code	Description
023829	CCS_SECC_TIMEOUT_SLACC_SDP_reserved_3
023830	CCS_SECC_TIMEOUT_SLACC_SDP_reserved_4
023831	CCS_SECC_TIMEOUT_SLACC_SDP_reserved_5
023832	CCS_SECC_TIMEOUT_V2G_Msg_Performance_Time_SupportedAppProtocolRes
023833	CCS_SECC_TIMEOUT_V2G_Msg_Performance_Time_SessionSetupRes
023834	CCS_SECC_TIMEOUT_V2G_Msg_Performance_Time_ServiceDiscoveryRes
023835	CCS_SECC_TIMEOUT_V2G_Msg_Performance_Time_ServicePaymentSelectionRes
023836	CCS_SECC_TIMEOUT_V2G_Msg_Performance_Time_ContractAuthenticationRes
023837	CCS_SECC_TIMEOUT_V2G_Msg_Performance_Time_ChargeParameterDiscoveryRes
023838	CCS_SECC_TIMEOUT_V2G_Msg_Performance_Time_PowerDeliveryRes
023839	CCS_SECC_TIMEOUT_V2G_Msg_Performance_Time_CableCheckRes
023840	CCS_SECC_TIMEOUT_V2G_Msg_Performance_Time_PreChargeRes
023841	CCS_SECC_TIMEOUT_V2G_Msg_Performance_Time_CurrentDemandRes
023842	CCS_SECC_TIMEOUT_V2G_Msg_Performance_Time_WeldingDetectionRes
023843	CCS_SECC_TIMEOUT_V2G_Msg_Performance_Time_SessionStopRes
023844	CCS_SECC_TIMEOUT_V2G_Sequence_Time
023845	CCS_SECC_TIMEOUT_V2G_ReadyToCharge_Performance_Time
023846	CCS_SECC_TIMEOUT_V2G_CommunicationSetup_Performance_Time
023847	CCS_SECC_TIMEOUT_V2G_CableCheck_Performance_Time
023848	CCS_SECC_TIMEOUT_V2G_CPState_Detection_Time
023849	CCS_SECC_TIMEOUT_V2G_CPOscillator_Retain_Time
023850	CCS_SECC_TIMEOUT_V2G_PreCharge_Performance_Time

Status Code	Description
023851	CCS_SECC_TIMEOUT_V2G_reserved_2
023852	CCS_SECC_TIMEOUT_V2G_reserved_3
023853	CCS_SECC_TIMEOUT_V2G_reserved_4
023854	CCS_SECC_TIMEOUT_V2G_reserved_5
023855	CCS_CAN_TIMEOUT_TP_GET_EV_TARGET_INFO
023856	CCS_CAN_TIMEOUT_TT_GET_EV_TARGET_INFO
023857	CCS_CAN_TIMEOUT_TP_GET_EV_BATTERY_INFO
023858	CCS_CAN_TIMEOUT_TT_GET_EV_BATTERY_INFO
023859	CCS_CAN_TIMEOUT_TP_EV_STOP_EVENT
023860	CCS_CAN_TIMEOUT_TT_EV_STOP_EVENT
023861	CCS_CAN_TIMEOUT_TP_EVSE_STOP_EVENT
023862	CCS_CAN_TIMEOUT_TT_EVSE_STOP_EVENT
023863	CCS_CAN_TIMEOUT_TP_GET_MISC_INFO
023864	CCS_CAN_TIMEOUT_TT_GET_MISC_INFO
023865	CCS_CAN_TIMEOUT_TP_DOWNLOAD_REQUEST
023866	CCS_CAN_TIMEOUT_TT_DOWNLOAD_REQUEST
023867	CCS_CAN_TIMEOUT_TP_START_BLOCK_TRANSFER
023868	CCS_CAN_TIMEOUT_TT_START_BLOCK_TRANSFER
023869	CCS_CAN_TIMEOUT_TP_DATA_TRANSFER
023870	CCS_CAN_TIMEOUT_TT_DATA_TRANSFER
023871	CCS_CAN_TIMEOUT_TP_DOWNLOAD_FINISH
023872	CCS_CAN_TIMEOUT_TT_DOWNLOAD_FINISH
023873	CCS_CAN_TIMEOUT_TP_ISOLATION_STATUS
023874	CCS_CAN_TIMEOUT_TT_ISOLATION_STATUS
023875	CCS_CAN_TIMEOUT_TP_CONNECTOR_INFO
023876	CCS_CAN_TIMEOUT_TT_CONNECTOR_INFO
023877	CCS_CAN_TIMEOUT_TT_RTC_INFO
023878	CCS_CAN_TIMEOUT_TP_RTC_INFO
023879	CCS_CAN_TIMEOUT_TP_EVSE_PRECHARGE_INFO
023880	CCS_CAN_TIMEOUT_TT_EVSE_PRECHARGE_INFO
023881	CCS_CAN_TIMEOUT_MSG_Sequence
023882	CCS_CAN_MSG_Unrecognized_CMD_ID

Status Code	Description
023883	CCS_SECC_DIN_Msg_Decode_Error
023884	CCS_SECC_DIN_Msg_Encode_Error
023885	CCS_SECC_ISO1_Msg_Decode_Error
023886	CCS_SECC_ISO1_Msg_Encode_Error
023887	CCS_SECC_ISO2_Msg_Decode_Error
023888	CCS_SECC_ISO2_Msg_Encode_Error
023889	CCS_SECC_CP_State_Error
023890	CCS_SECC_Unexpected_60V_Before_Charing_Error
023891	CCS_SECC_Not_Ready_For_Charging
023892	CCS_SECC_TIMEOUT_QCA7000_COMM (The firmware code of QCA7000 may not be installed, yet)
023893	CCS_SECC_FAIL_QCA7000_SETKEY
023894	Reserved
023895	Reserved
023896	Reserved
023897	Reserved
023898	Reserved
023899	Reserved
023900	GBT_LOS_CC1
023901	GBT_CONNECTOR_LOCK_FAIL
023902	GBT_BATTERY_INCOMPATIBLE
023903	GBT_BMS_BROAA_TIMEOUT
023904	GBT_CSU_PRECHARGE_TIMEOUT
023905	GBT_BMS_PRESENT_VOLTAGE_FAULT
023906	GBT_BMS_VOLTAGE_OVER_RANGE
023907	GBT_BSM_CHARGE_ALLOW_00_10MIN_COUUNTDONE
023908	GBT_WAIT_GROUNDFULT_TIMEOUT
023909	GBT_ADC_MORE_THAN_10V
023910	GBT_ADC_MORE_THAN_60V
023911	GBT_CHARGER_GET_NORMAL_STOP_CMD
023912	GBT_CHARGER_GET_EMERGENCY_STOP_CMD
023913	GBT_ISOLATION_RESULT_FAIL

Status Code	Description
023914	GBT_MOTHER_BOARD_MISS_LINK
023915	GBT_OUTPUT_VOLTAGE_MORE_THAN_LIMIT
023916	GBT_REQ_CURRENT_MORE_THAN_LIMIT
023917	GBT_OUTPUT_VOLTAGE_MORE_THAN_10_PERCENT
023918	GBT_OUTPUT_VOLTAGE_DIFF_BCS_5_PERCENT
023919	GBT_STOP_ADC_MORE_THAN_10V
023920	Reserved
023921	Reserved
023922	Reserved
023923	Reserved
023924	Reserved
023925	Reserved
023926	Reserved
023927	Reserved
023928	Reserved
023929	Reserved
023930	GBT_CEM_BHM_TIMEOUT
023931	GBT_CEM_BRM_TIMEOUT
023932	GBT_CEM_BCP_TIMEOUT
023933	GBT_CEM_BRO_TIMEOUT
023934	GBT_CEM_BCL_TIMEOUT
023935	GBT_CEM_BCS_TIMEOUT
023936	GBT_CEM_BSM_TIMEOUT
023937	GBT_CEM_BST_TIMEOUT
023938	GBT_CEM_BSD_TIMEOUT
023939	GBT_CEM_BEM_OTHER_TIMEOUT
023940	GBT_BEM_CRM_TIMEOUT
023941	GBT_BEM_CRMAA_TIMEOUT
023942	GBT_BEM_CTS_CML_TIMEOUT
023943	GBT_BEM_CRO_TIMEOUT
023944	GBT_BEM_CCS_TIMEOUT
023945	GBT_BEM_CST_TIMEOUT

Status Code	Description
023946	GBT_BEM_CSD_TIMEOUT
023947	GBT_BEM_BEM_OTHER_TIMEOUT
023948	Reserved
023949	Reserved
023950	GBT_BST_SOC_GOAL
023951	GBT_BST_TOTAL_VOLTAGE_GOAL
023952	GBT_BST_CELL_VOLTAGE_GOAL
023953	GBT_BST_GET_CST
023954	GBT_BST_ISOLATION
023955	GBT_BST_OUTPUT_CONNECTOR_OTP
023956	GBT_BST_COMPONENT
023957	GBT_BST_CHARGE_CONNECTOR
023958	GBT_BST_OTP
023959	GBT_BST_OTHER
023960	GBT_BST_HIGH_V
023961	GBT_BST_CC2
023962	GBT_BST_CURRENT
023963	GBT_BST_VOLTAGE
023964	GBT_GET_BST_NO_REASON
023965	Reserved
023966	Reserved
023967	Reserved
023968	Reserved
023969	Reserved
023970	GBT_BSM_CELL_OVER_VOLTAGE
023971	GBT_BSM_CELL_UNDER_VOLTAGE
023972	GBT_BSM_OVER_SOC
023973	GBT_BSM_UNDER_SOC
023974	GBT_BSM_CURRENT
023975	GBT_BSM_TEMPERATURE
023976	GBT_BSM_ISOLATE
023977	GBT_BSM_OUTPUT_CONNECTOR

Status Code	Description
023978	
023979	EV full charging
023980	ERROR_CODE_CHADEMO_BMS_CHARGE_ALLOW_ERROR
023981	ERROR_CODE_CHADEMO_OUTPUT_VOLTAGE_MORE_THAN_10_PERCENT
023982	ERROR_CODE_CHADEMO_ADC_LESS_THAN_10V
023983	STOP by EV
033900	disconnected from backend through Ethernet
033901	disconnected from backend through WiFi
033902	disconnected from backend through 3G/4G
033903	Remote start charging by backend
033904	Remote stop charging by backend
033905	Remote reset by backend
033906	Reserved
033907	Reserved
041004	RCD/CCID self-test fail
041005	AC input contactor 1 welding
041006	AC input contactor 1 driving fault
041007	AC input contactor 2 welding
041008	AC input contactor 2 driving fault
041009	AC output relay welding
041010	AC output relay driving fault
041017	AC connector temperature sensor broken
041021	WiFi module broken
041022	3G/4G module broken
041023	Aux. power module broken
041024	Relay control module /smart box broken
041031	PSU module broken
041032	RCD/CCID module broken
041033	Maximum Output Current setup error
041034	Shutter fault
041035	Ble module broken

Status Code	Description
041036	Rotary switch fault
042200	System L1 input OVP
042201	System L2 input OVP
042202	System L3 input OVP
042203	System L1 input UVP
042204	System L2 input UVP
042205	System L3 input UVP
042206	PSU L1 input OVP
042207	PSU L2 input OVP
042208	PSU L3 input OVP
042209	PSU L1 input UVP
042210	PSU L2 input UVP
042211	PSU L3 input UVP
042212	System L1 input drop
042213	System L2 input drop
042214	System L3 input drop
042223	System ambient/inlet OTP
042224	System critical point OTP
042225	PSU ambient/inlet OTP
042226	PSU critical point OTP
042227	Aux. power module OTP
042228	Relay board/smart box OTP
042232	AC connector OTP
042233	RCD/CCID trip
042237	SPD trip
042238	Main power breaker trip
042239	Aux. power breaker trip
042240	PSU communication fail
042241	WiFi module communication fail
042242	3G/4G module communication fail
042244	Bluetooth module communication fail
042246	Aux. power module communication fail

Status Code	Description
042247	Relay control board/smart box communication fail
042251	Emergency stop
042252	Door open
042253	System fan decay
042254	Fail to create share memory
042255	CSU initialization failed
042257	MCU self-test Fault
042258	Relay self-test Fault
042262	System AC L1 output Circuit Short
042263	PSU Duplicate ID
042264	PSU Output Short Circuit
042265	PSU Discharge Abnormal
042266	PSU Dc Side ShutDown
042267	PSU Failure Alarm
042268	PSU Protection Alarm
042269	PSU FanFailure Alarm
042270	PSU Input UVP
042271	PSU Input OVP
042272	PSU WalkIn State
042273	PSU Power Limited State
042274	PSU Id Repeat
042275	PSU Severe Uneven Current
042276	PSU Three Phase Input Inadequate
042277	PSU Three Phase Onput Imbalance
042278	PSU Ffc Side ShutDown
042279	NO PSU Resource
042280	Self test Failed due to communication of Relayboard failure
042281	Self test Failed due to communication of Fanboard failure
042282	Self test Failed due to communication of Primary failure
042283	Self test Failed due to communication of Chademoboard failure
042284	Self test Failed due to communication of CCSboard failure
042285	Self test Failed due to AC Contact failure

Status Code	Description
042286	Self test Failed due to communication of PSU failure
042287	Self test Failed due to Model name is none match
042291	Self test Failed due to communication of GBTboard failure
042292	Self test Failed due to communication of AC failure
042293	Self test Failed due to communication of Ledboard failure
042294	AC input ovp
042295	AC input uvp
042299	System AC L2 output OCP
042300	System AC L3 output OCP
042301	System AC L2 output Circuit Short
042302	System AC L3 output Circuit Short
042305	Meter communication timeout
042306	The dip switch of the PSU may be incorrect
042307	Psu Fuse Burn-Out
042308	Psu Pfc And Dcdc Communication Fault
042309	Psu Bus Voltage Unbalance
042310	Psu Bus Over Voltage
042311	Psu Bus Voltage Abnormal
042312	Psu Bus Under Voltage
042313	Psu Input Phase Loss
042314	Psu Fan Full Speed
042315	Psu Temperature Power Limit
042316	Psu Ac Power Limit
042317	Psu Dcdc Eeprom Fault
042318	Psu Pfc Eeprom Fault
042319	Psu Dcdc Over Voltage
043600	Normal stop charging by user
043601	Charging Time's up
043602	Replace system air filter
043607	CSU fimrware update fail
043611	Aux. power module fimrware update fail
043612	Relay control module fimrware update fail

Status Code	Description
043614	Bluetooth module firmware update fail
043615	WiFi module firmware update fail
043616	3G/4G module firmware update fail
043617	SMR firmware update fail
043618	RFID module firmware update fail
043619	configured by USB flash drive
043620	configured by backend
043621	configured by webpage
043622	disconnected from Internet through Ethernet
043623	disconnected from Internet through WiFi
043624	disconnected from Internet through 3G/4G
043625	disconnected from AP through WiFi
043626	disconnected from APN through 3G/4G
043627	WiFi disabled (separated charger only)
043628	4G disabled (separated charger only)

6. Maintenance

6.1 General Maintenance

- The DC Fast Charger is cooled by forced air. Please keep charger in a ventilated location and do not block the air vents of the DC Fast Charger .
- Please clean or replace the air filters regularly to ensure the DC Fast Charger works properly.
- The housing was made of welding process and surface painting. It is necessary to keep the exterior clean all the time. It's easy to get rusty if not keeping the exterior clean especially in corrosion sensitive environment. Slightly rusty will not affect charger performance, but if charger is serious rusty during or exceed the warranty period, please contact local vendor for instruction.
- Clean the DC fast Charger at least three times a year, keep the exterior clean at all times.
- Clean the outside of the cabinet with damp cloth or wet cotton towel, only use low-pressure tap water and cleaning agents with PH level between 6 to 8.
- Do not apply high-pressure water jets.
- Do not use cleaning agents with abrasive components and do not use abrasive tools. Improper cleaning agents might spoiled coating, painting, surface, brightness and durability of all exterior parts.
- If there is water intruding into the DC Fast Charger then please cut off the power source immediately and contact the DC Fast Charger provider for repair.
- Please make sure the charging connector is returned to the holder of the charging connector after charging to prevent damage.
- If there is damage to the charging connector, charging cable or holder of the charging connector then please contact the DC Fast Charger provider.
- When using the DC Fast Charger please handle properly. Do not strike or scrape the cabinet or screen.
- If the enclosure or screen is broken, cracked, open or shows any other indication of damage then please contact the Standalone DC Fast Charger provider.



WARNING: Danger of electrical shock or injury. Turn OFF power at the panelboard or load center before working on the equipment or removing any component. Do not remove circuit protective devices or any other component until the power is turned OFF.

- Disconnect electrical power to the DC Fast Charger before any maintenance work to ensure it is separated from the supply of AC mains. Failure to do so may cause physical injury or damage to the electrical system and charging unit.

Note:

- Before switching off main breaker to begin maintenance, please record the status code number on the LCD monitor.
- Maintenance of the DC Fast Charger shall be conducted only by a qualified technician.
- After opening the front door of the DC Fast Charger, turn off the main breaker and auxiliary breaker before any maintenance work.
- Replace the ventilation filter every six to twelve months.
- Check the connection of inner cables monthly.
- Please provide the EVSE information including serial number, model name, status code, failure behavior and timing, and also connect the EVSE to the Internet before remote diagnostics and upgrading.
- Due to the liquid CCS1/2 connector high output current, if the adapter issue or environmental factor e.g., the charger, or the adapter is exposed to severe rain, snow, electrical storm, or other inclement weather result in changing equipment error, fire, electrical shock, serious injury or death. This warranty does not cover the damages result in resulting from adapter accident or damages resulting from unauthorized service.

6.2 Replacement Kits and Accessories

The DC EVSE offers the following replacement kits and accessories.

Replacement Kit List
7-inch LCD
CCS1/CHAdeMO 65Amp (or above) DC charging connector & 4M charging cable
Charging Cable Holder
Emergency Stop Button
Front Door
30kW DC PSU U-1K0100
MW Aux. Power HEP-100-12V
MW Aux. Power HEP-185-24V
Control & Supervisory Unit (CSU)
Surge Protection Device (SPD)
DC Fan
Air Filters
RFID Readers
Door Key

7. Limited Product Warranty

The warranty period for this charger is three years.

Any spare parts provided by Electric Avenue Manufacturing Inc. and used as replacements for repair are covered by a five-year guarantee.

Replacement and repair parts manufactured by alternative manufacturers to those on the maintenance parts are only allowed if authorized by Electric Avenue.

The housing was made of welding process and surface painting. It is necessary to keep the exterior clean all the time. It's easy to get rusty if not keeping the exterior clean especially in corrosion sensitive environment. Slightly rusty will not affect charger performance, but if charger is serious rusty during or exceed the warranty period, please contact local vendor for instruction.

Warranty Exclusions:

- Damage or rendered non-functional as a result of power surges, lighting, earthquake, fire.
- Flood, pest damage, abuse, accident, misuse, negligence or failure to maintain the product or other event beyond Electric Avenue's reasonable control or not arising from normal operating condition.
- Cosmetic or superficial defect, dents, marks or scratches after use.
- Components which are separate from the product, ancillary equipment and consumables, such as door key, RFID card, quick guide, air filter, fuse, cable, wires and connectors.
- Damage as a result of modifications, alterations or disassembling which were not pre-authorized in writing by Electric Avenue.
- Damage due to the failure to observe the applicable safety regulations governing the proper use of the product.
- Installed or operated not in strict conformance with the documentation, including without limitation, not ensuring sufficient ventilation for the product as described in Electric Avenue's installation instruction.

If a defect in the product arises and valid claim is received within the warranty period, your sole and exclusive remedy will be for Electric Avenue, at its sole discretion and to extent permitted by law, to

1. Repair the defect in the product at no charge, using new or refurbished parts.
2. Exchange the product with new or refurbished product that is functionally equivalent to the original product.

Any remedy hardware product will be warranted for the remainder of the original warranty period or 90 days from delivery to the customer, whichever is longer.

In order to receive the remedy set for above, you must contact Electric Avenue during the warranty period and provide the model number, series number, proof of purchase, and date of purchase.

This warranty does not cover the damages result in resulting from adapter accident or damages resulting from unauthorized service.

Appendix - Package list

Item	Description	Quantity	Remark
1	EVSE	1	
2	User Manual	1	
3	OQC Report	1	
4	RFID Card	2	
5	Key of Cabinet	2	
6	Wall-Mounted Bracket	1	
7	Gun Holder	-	Single Gun*1pcs, Dual Gun*2pcs Refer to Chapter 2.2 Table
8	5/16" Expansion Screw	4	Each Gun Holder*2pcs
9	3/8" Expansion Screw	4	Wall-Mounted Bracket*4pcs
10	M6 Screw	2	Wall-Mounted Bracket*2pcs
11	2.5mm Ball-Head Hex Key	1	



Manufacturer Contact Info Sticker

