

**G-FORCE**

**S10**  
**OWNERS MANUAL**

V 1.1 | 2023  
[www.g-forcebike.com](http://www.g-forcebike.com)

# TABLE OF CONTENTS

<b>Table of Contents</b> .....	2
<b>WARNING</b> .....	3
<b>Unboxing</b> .....	5
What's in the Box .....	5
Frame Number and Motor Number .....	5
<b>E-Scooter Structure Introduction</b> .....	6
Installation of Integral Body .....	7
How to Fold The E-Scooter .....	8
Adjust The Handlebar Height .....	8
How to Charge .....	9
<b>Instrument Introduction</b> .....	10
Turn The Scooter On/Off .....	11
Upshift/Downshift.....	11
Lighting System .....	12
<b>Safety Notes</b> .....	14
OPERATING SAFETY .....	14
Helmets and Local Laws .....	14
Pre-ride Safety Check and Inspection .....	14
Riding in Wet Conditions .....	14
<b>PRE-RIDE SAFETY CHECK</b> .....	15
<b>ERROR CODES</b> .....	15
<b>WARRANTY</b> .....	16
<b>DISCLAIMER</b> .....	18



# WARNING!

Read this entire manual before assembling or using your new electric scooter.

Do not modify, disassemble, or replace the original electrical components on your scooter. Doing so will invalidate your warranty and could put you in danger. Riding any type of scooter comes with some risks which can't be predicted or avoided. Taking proper care of scooter components can lower the risk of sudden failure of components but cannot prevent it. These sudden failures could cause serious harm, injury, or death to the rider. If you notice abnormalities in any component on the scooter, take it to a li-

G-force Inc assumes no liability for harm, injury, or death of the rider. This manual is not intended to function as a detailed service manual.

G-force recommends having your local scooter shop mechanic perform a detailed safety check of your scooter before your first ride. Ensure your local mechanic is experienced and reputable. G-FORCE S10 can withstand most rain showers without sustaining damage. The scooter has an IP rating of 65. This means it is dust tight and can withstand jetting water. See the IP code for more details. It does not mean that the scooter and its mechanical and electrical components are waterproof. We do not recommend storing or using the scooter in excessively wet conditions. The warranty for the G-FORCE S10 does not cover water damage.



# **THANK YOU FOR YOUR PURCHASE!**

We appreciate your purchase and we hope you thoroughly enjoy riding your E-Scooter.

If you need any assistance or have any questions please feel free to contact us.

## **CONTACT INFORMATION**

Email: [support@g-forcebike.com](mailto:support@g-forcebike.com)

Website: [www.g-forcebike.com](http://www.g-forcebike.com)

Phone: (909)330-6521



## UNBOXING

Congratulations on your purchase of a new G-Force E-Scooter! Your scooter and related accessories are inside your box, and the instructions below are meant to show you all the parts inside the box. Before removing the packing foam, please take out all the parts to confirm if there are any missing parts.

If any parts are missing or damaged, please contact G-Force customer service as soon as possible.

**⚠ Note:** If you are installing or riding a scooter for the first time, we recommend that you seek professional help, preferably from a certified scooter mechanic.

### What's in the box:

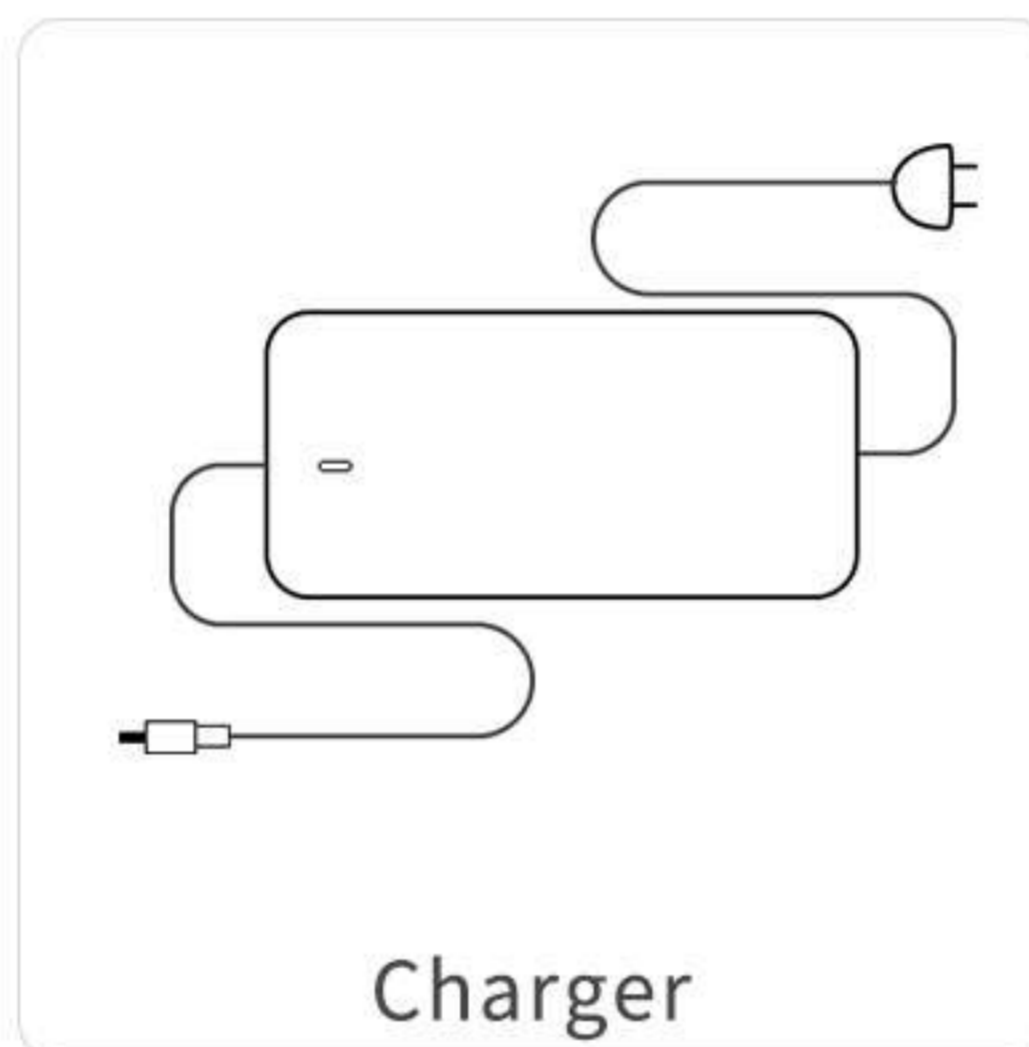

## FRAME NUMBER AND MOTOR NUMBER

Your scooter has two unique serial numbers on the frame and on the motor. As shown in the picture

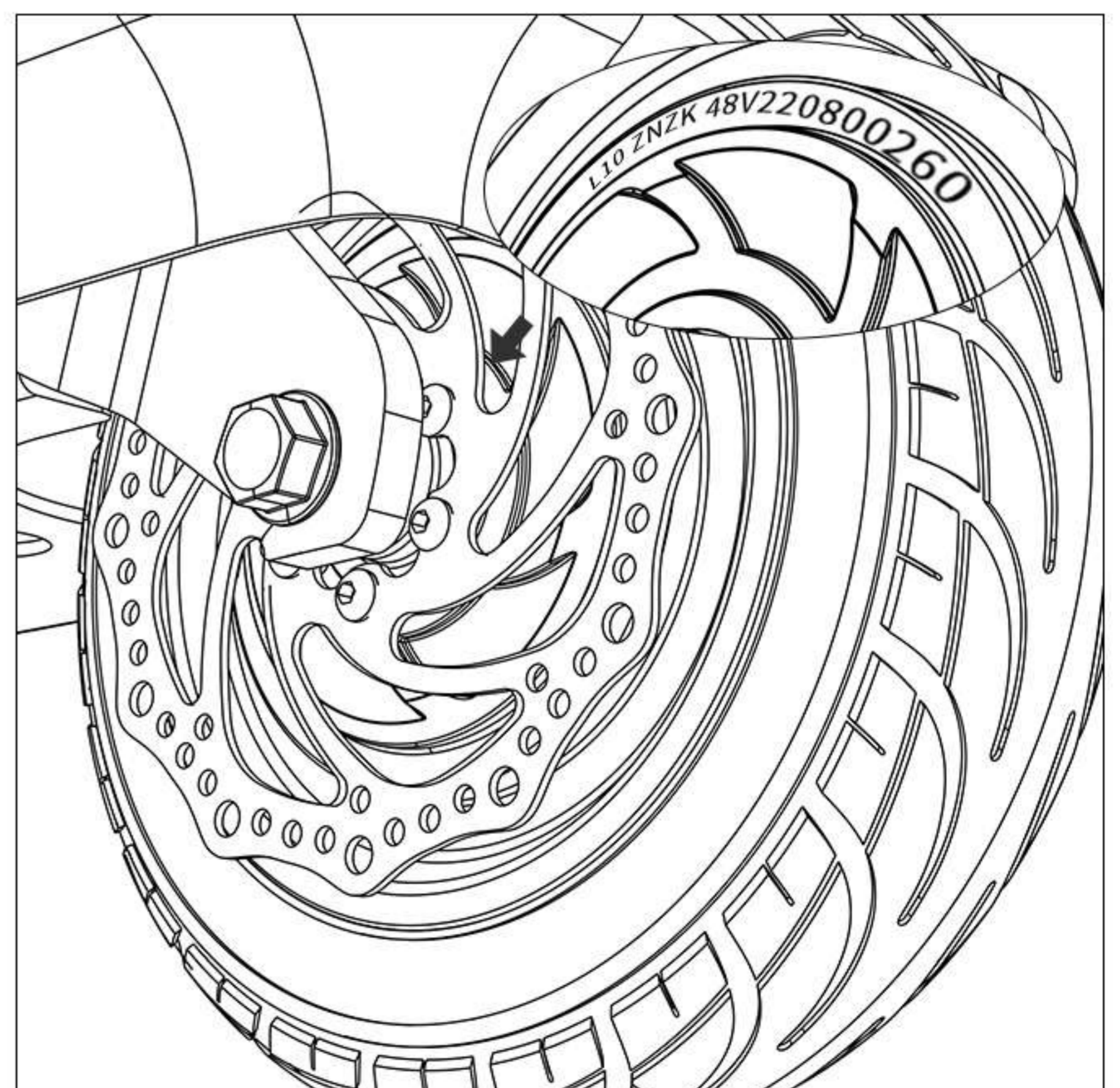
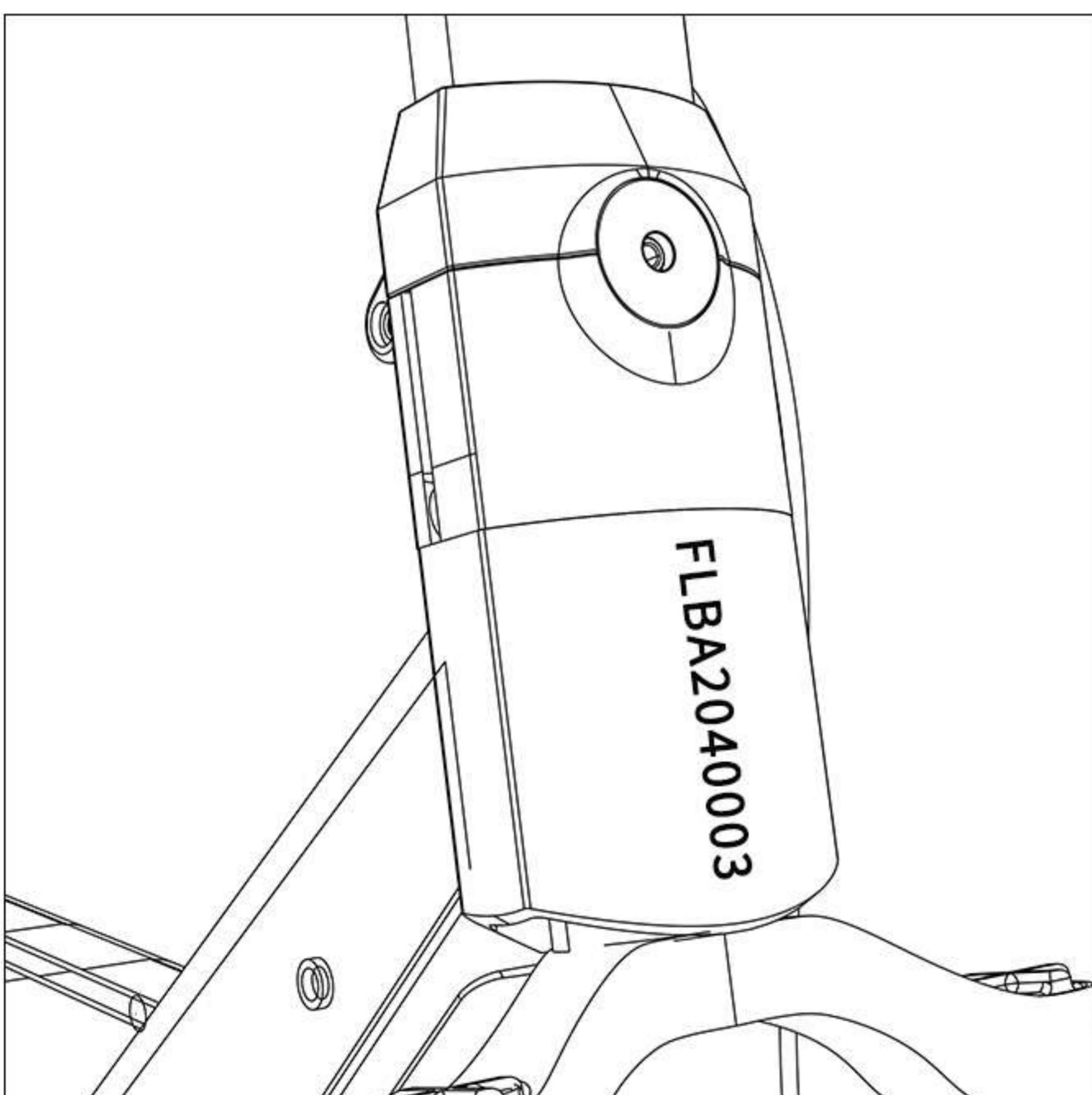



Please find the serial number and motor number on your scooter and record them. The motor number and frame number will be the proof of the warranty. Also, electric car is stolen, you can provide the frame number for law enforcement.

## E-SCOOTER STRUCTURE INTRODUCTION

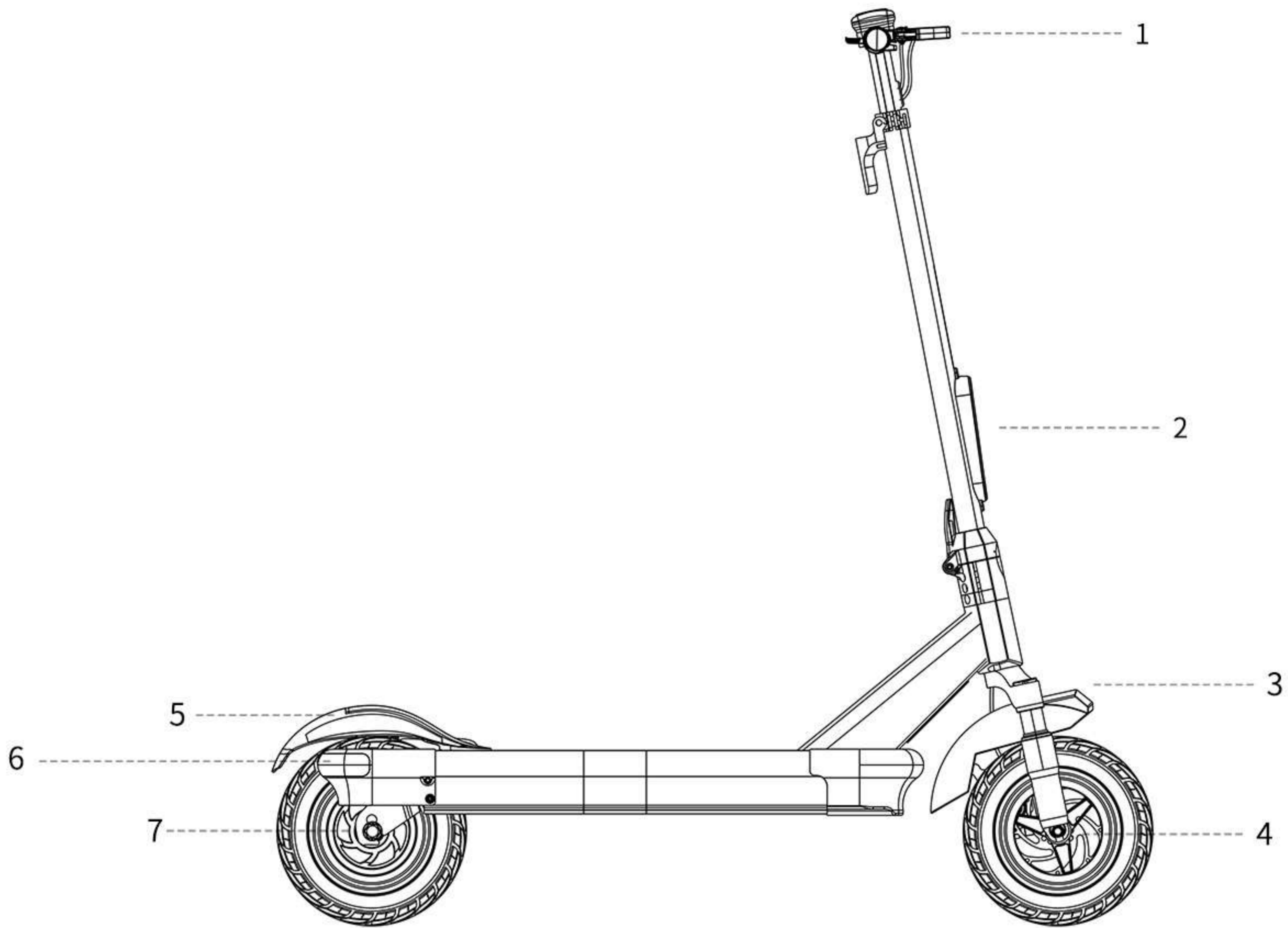

- 1. Handlebar
- 2. Headlight
- 3. Front fender
- 4. Brake disc
- 5. Rear light
- 6. Rear fender
- 7. Motor

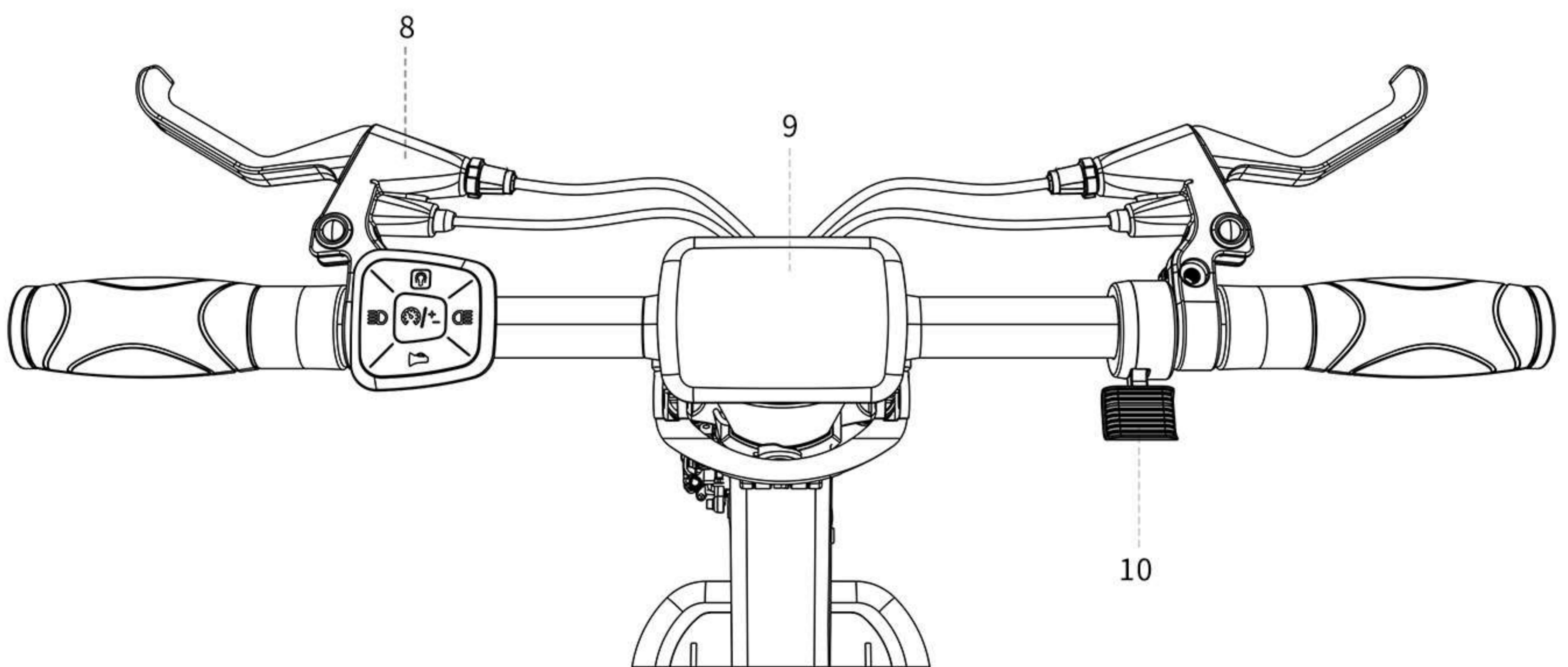

- 8. Front brake lever
- 9. Display
- 10. Thumb throttle



## INSTALLATION OF INTEGRAL BODY

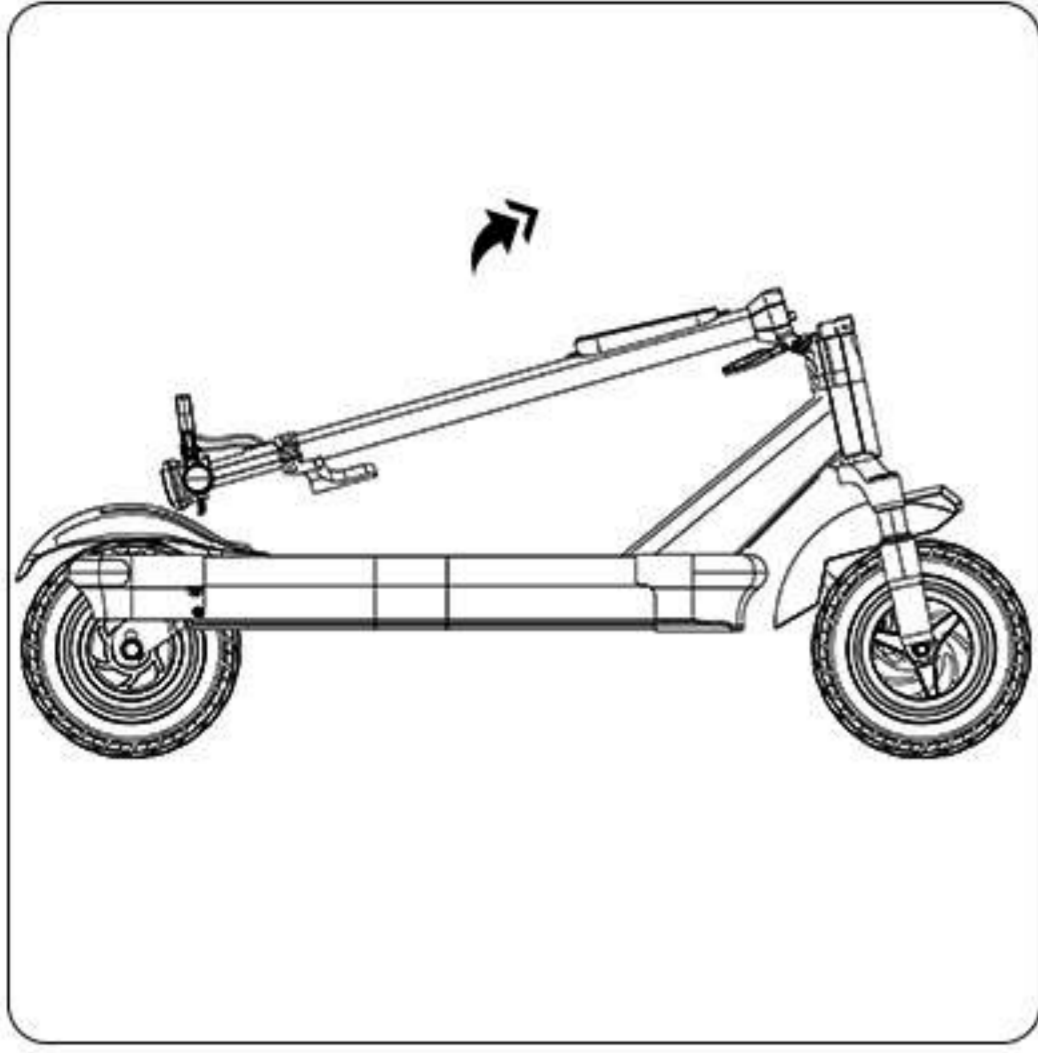

1. Unfold the scooter by grasping the handlebar stem and gently lifting it up towards the front wheel.



2. Pull the stem release lever (the folding latch) up

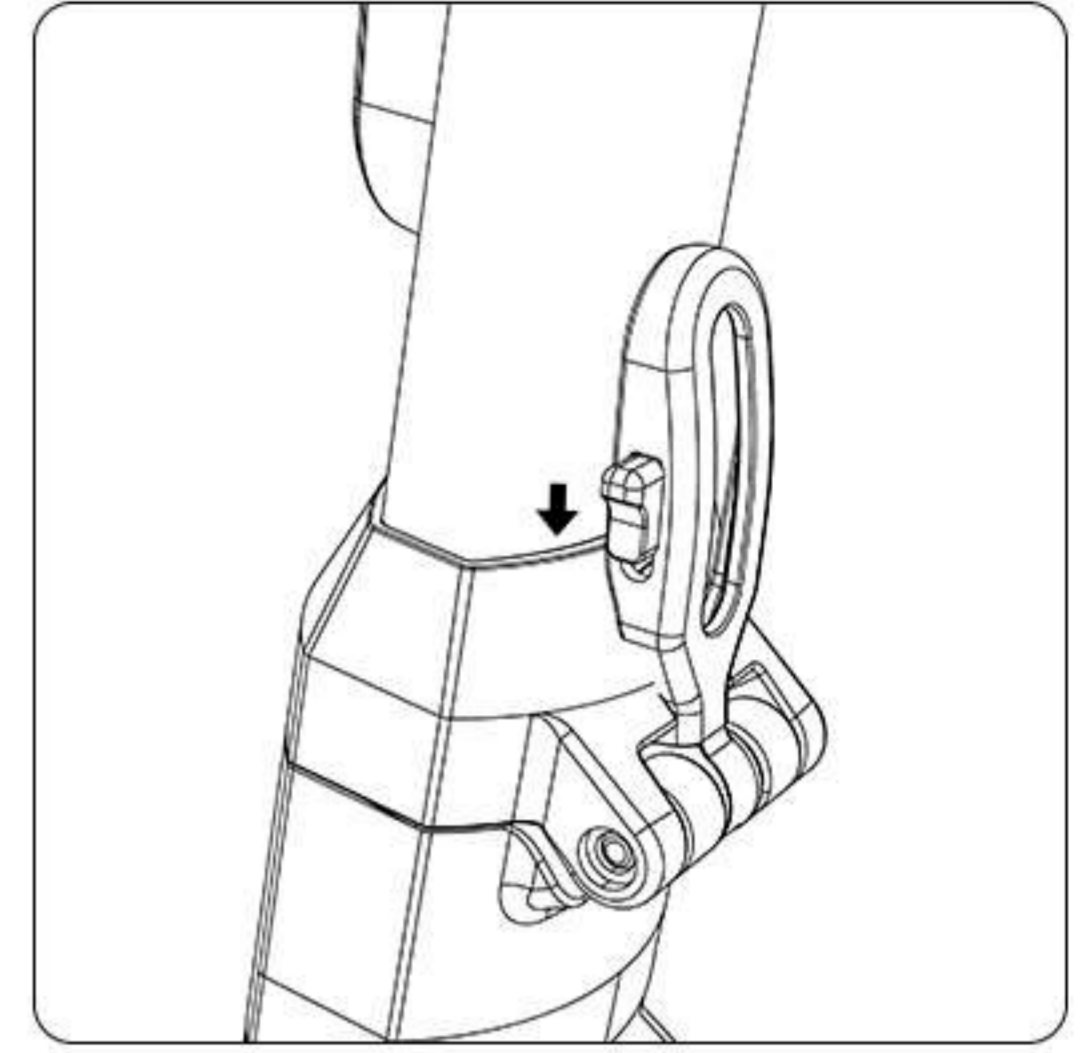

3. Push it inward to lock the stem in place.

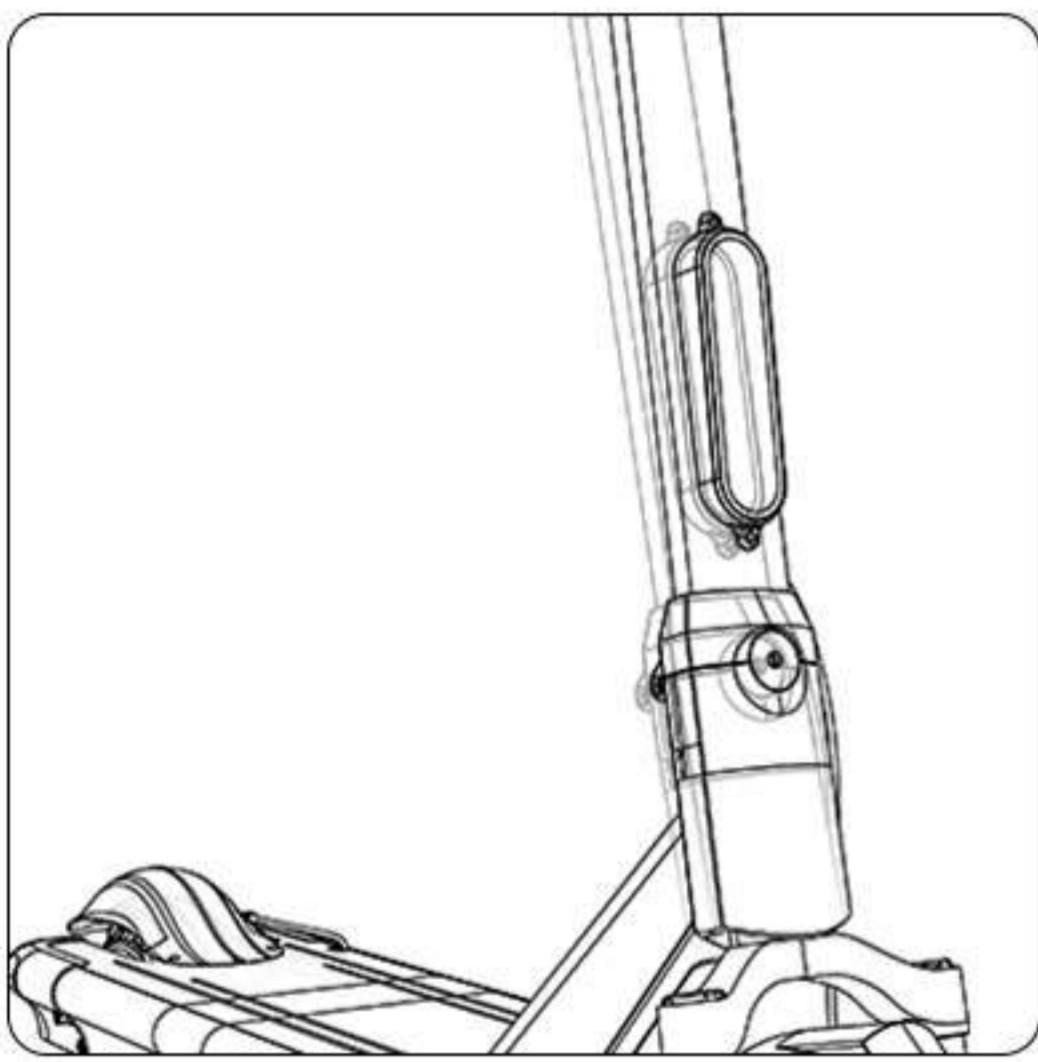

4. if you feel some wiggle with the steering column

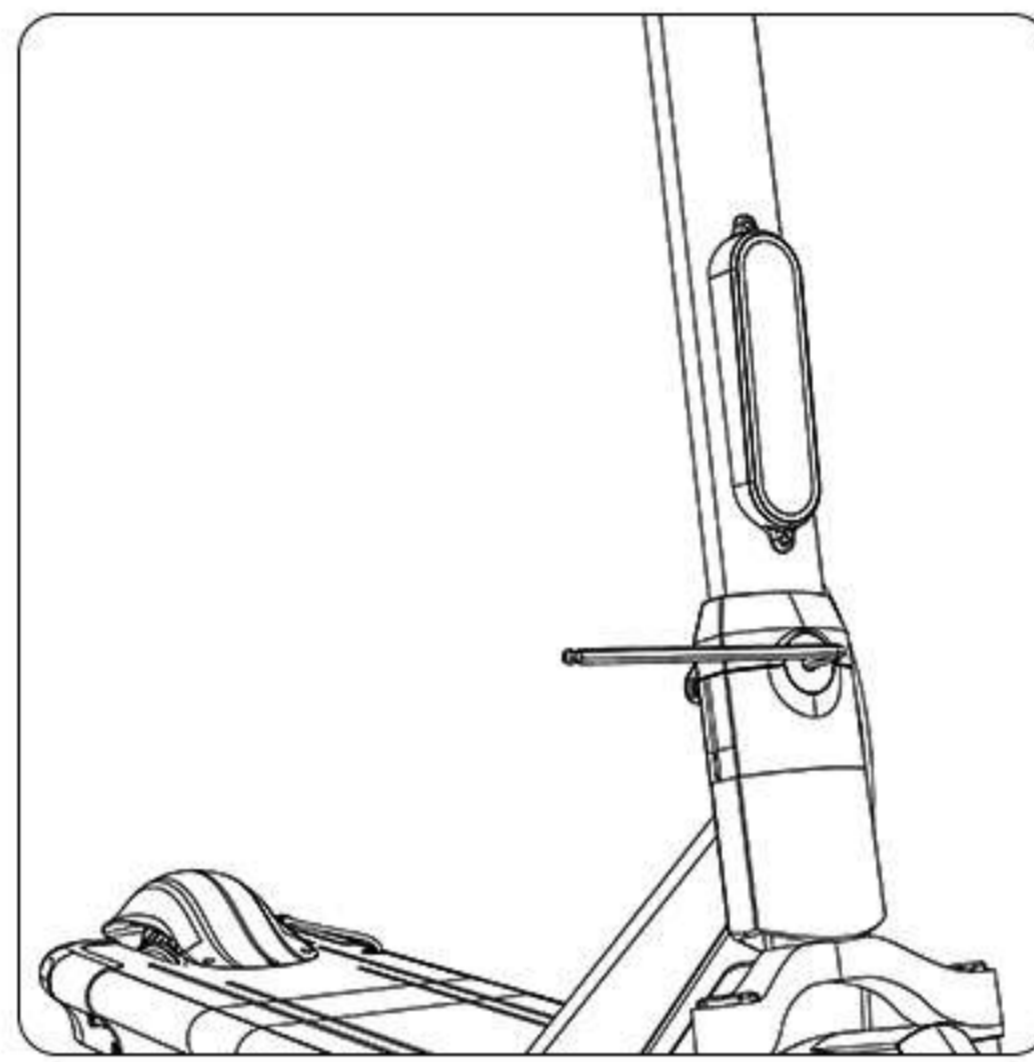

5. pick up a 4mm Allen key inside the tool kit bag to tighten the set screw at the front.

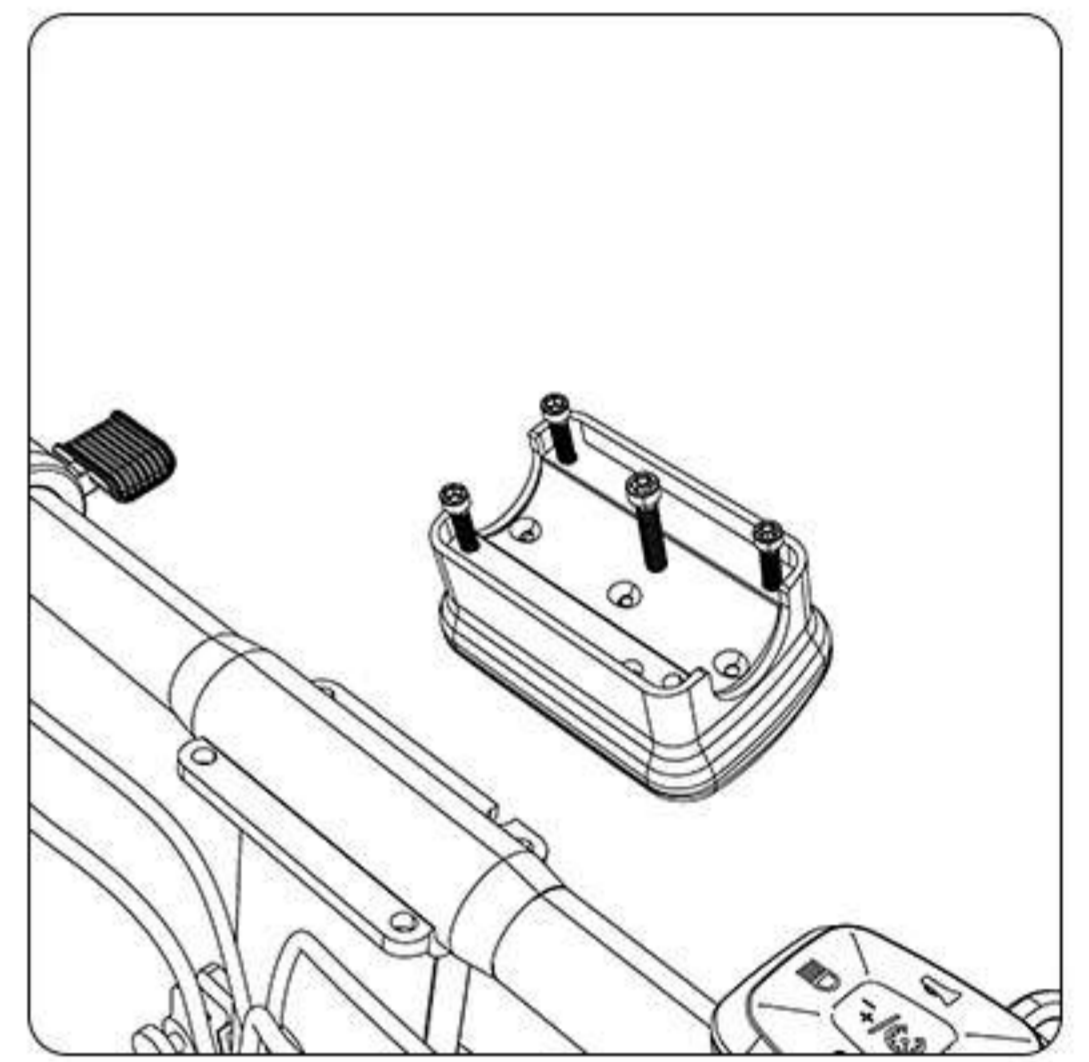

6. pick up a 4mm Allen key inside the tool kit bag to tighten the set screw at the front. remove these four screws with 4mm Allen key.

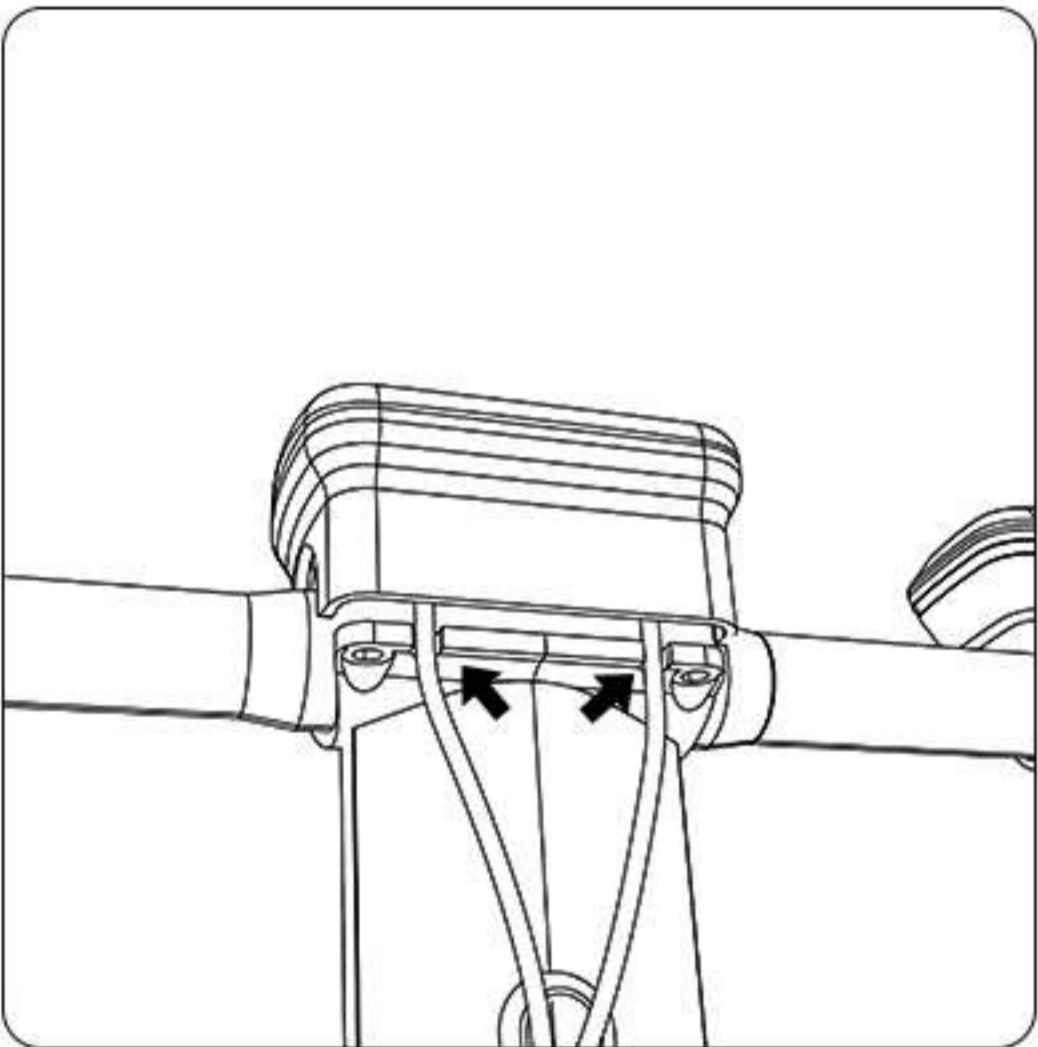

7. put the LCD display block on by threading its two outgoing wires through the openings.

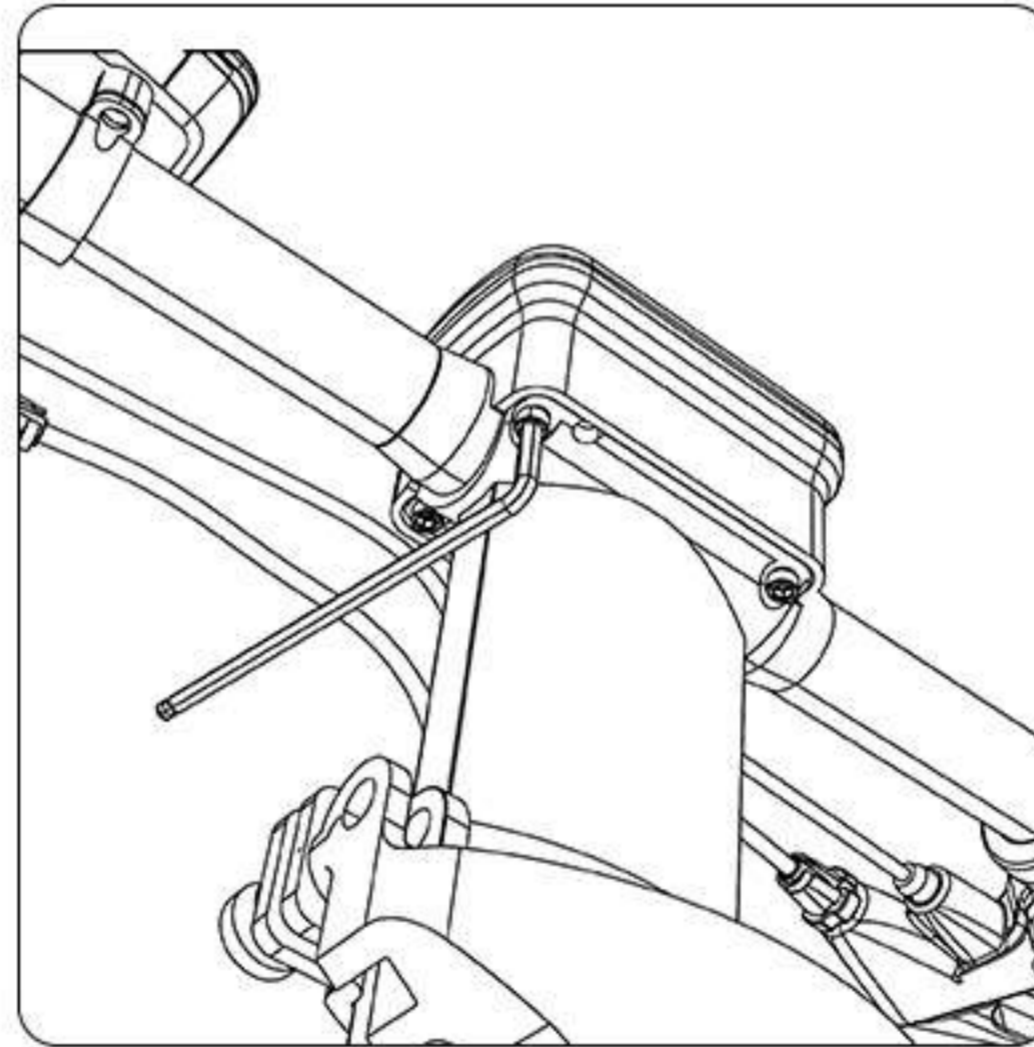

8. Set up the handlebar to your preference, make sure the handlebar is centered, then fully tighten the face plate bolts in an X pattern.





Note: The recommended tire pressure range is 20-28PSI, with a peak pressure of 30PSI. you can choose the right tire pressure based on weight, terrain, and other factors.

## HOW TO FOLD THE SCOOTER

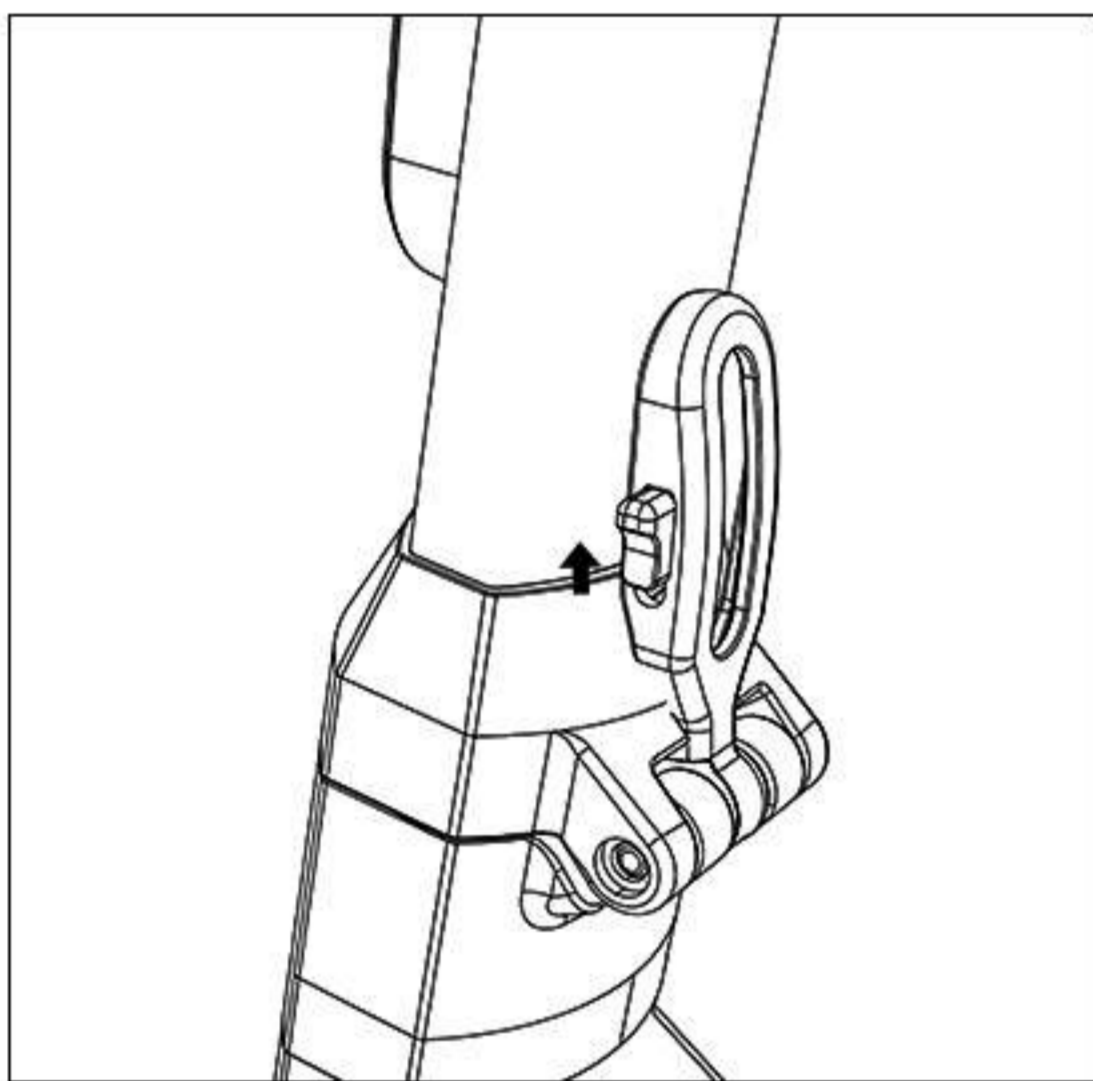

1. Slide the side up



2. Then open the folding handle.

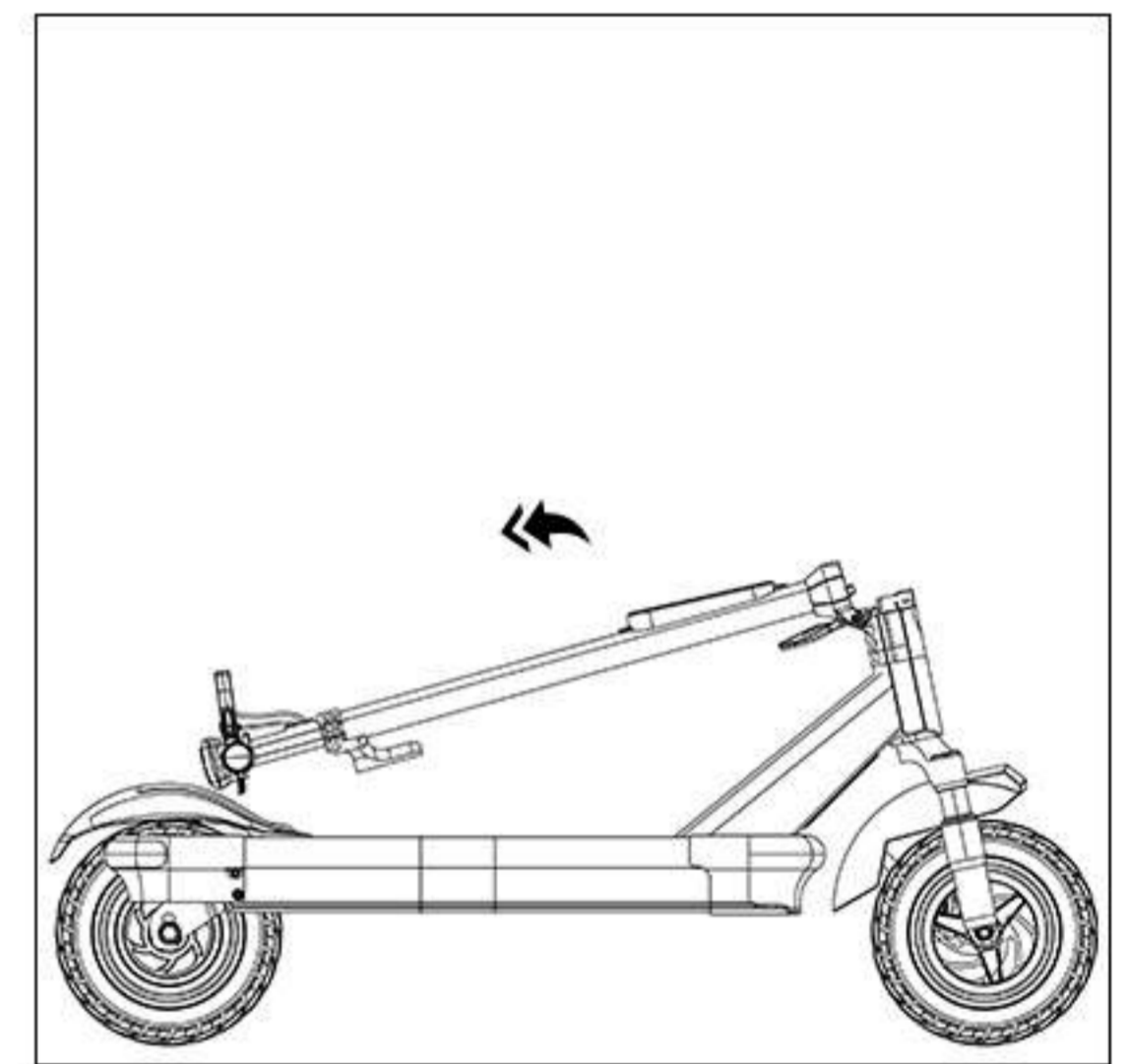

3. Fold the riser and handle

## ADJUST THE HANDLEBAR HEIGHT

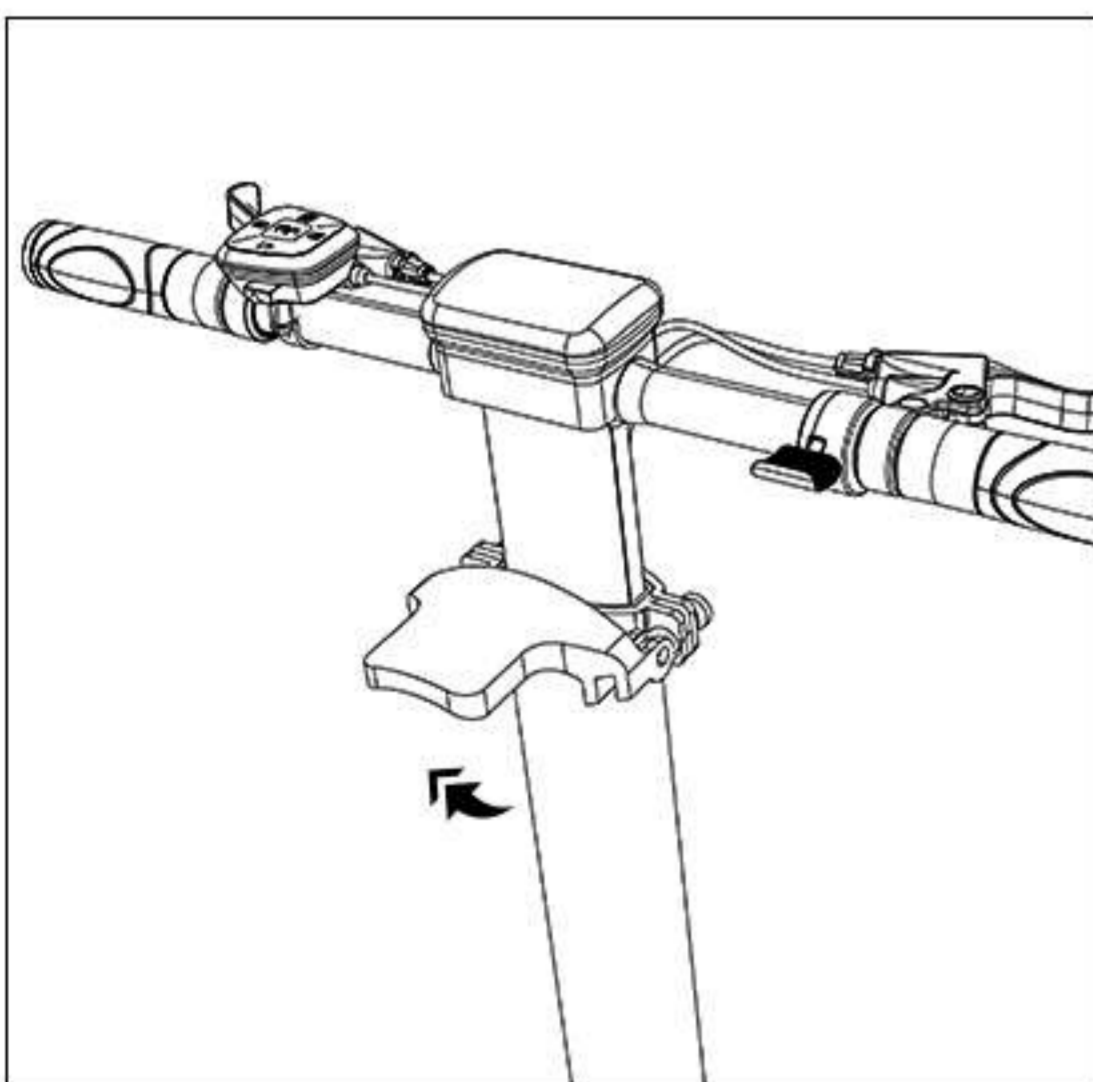

1. Unclamp the handlebar stem quick-release lever to slide the upper stem up/ down.

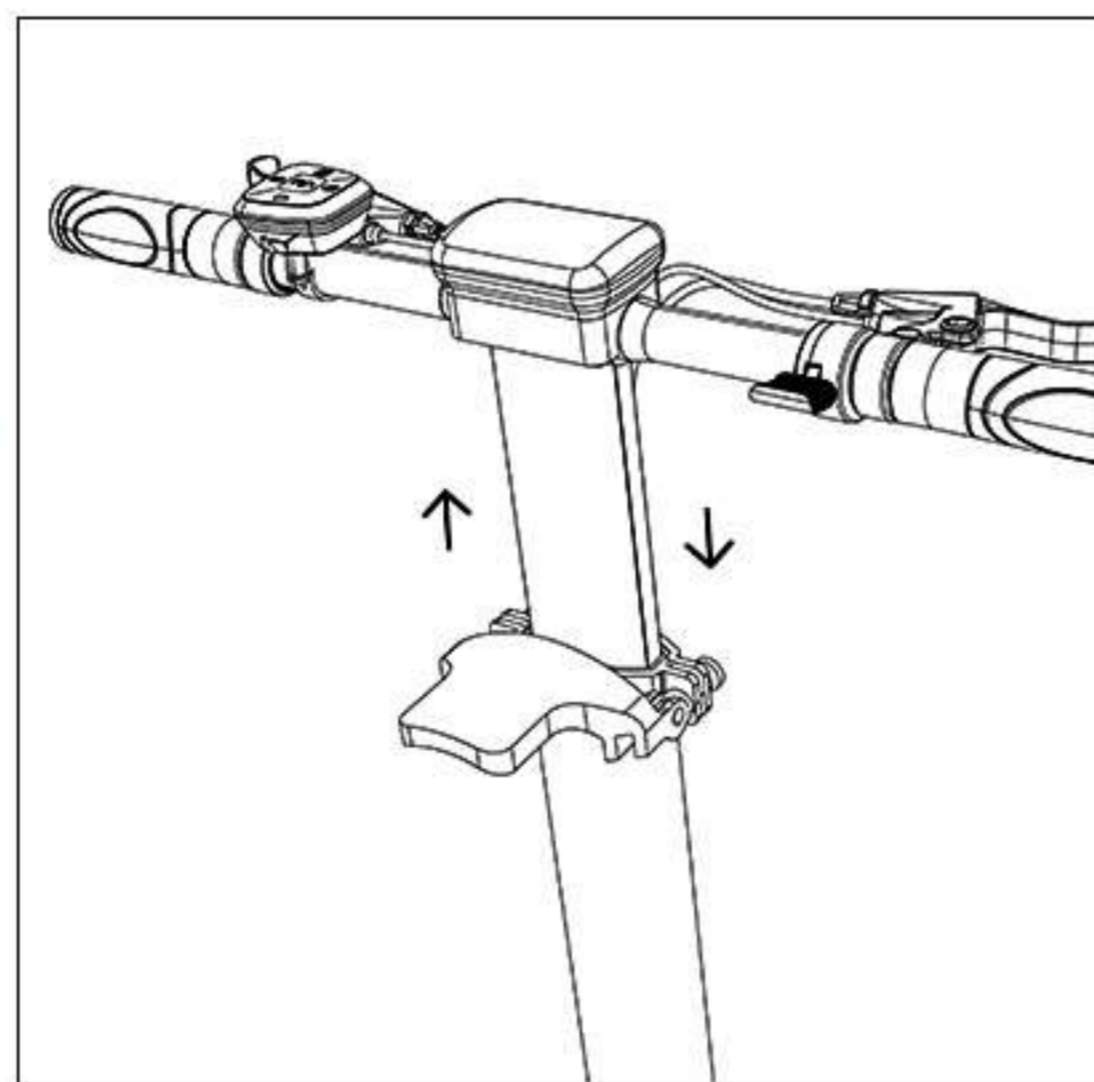

2. Raise or lower the handlebar height as needed

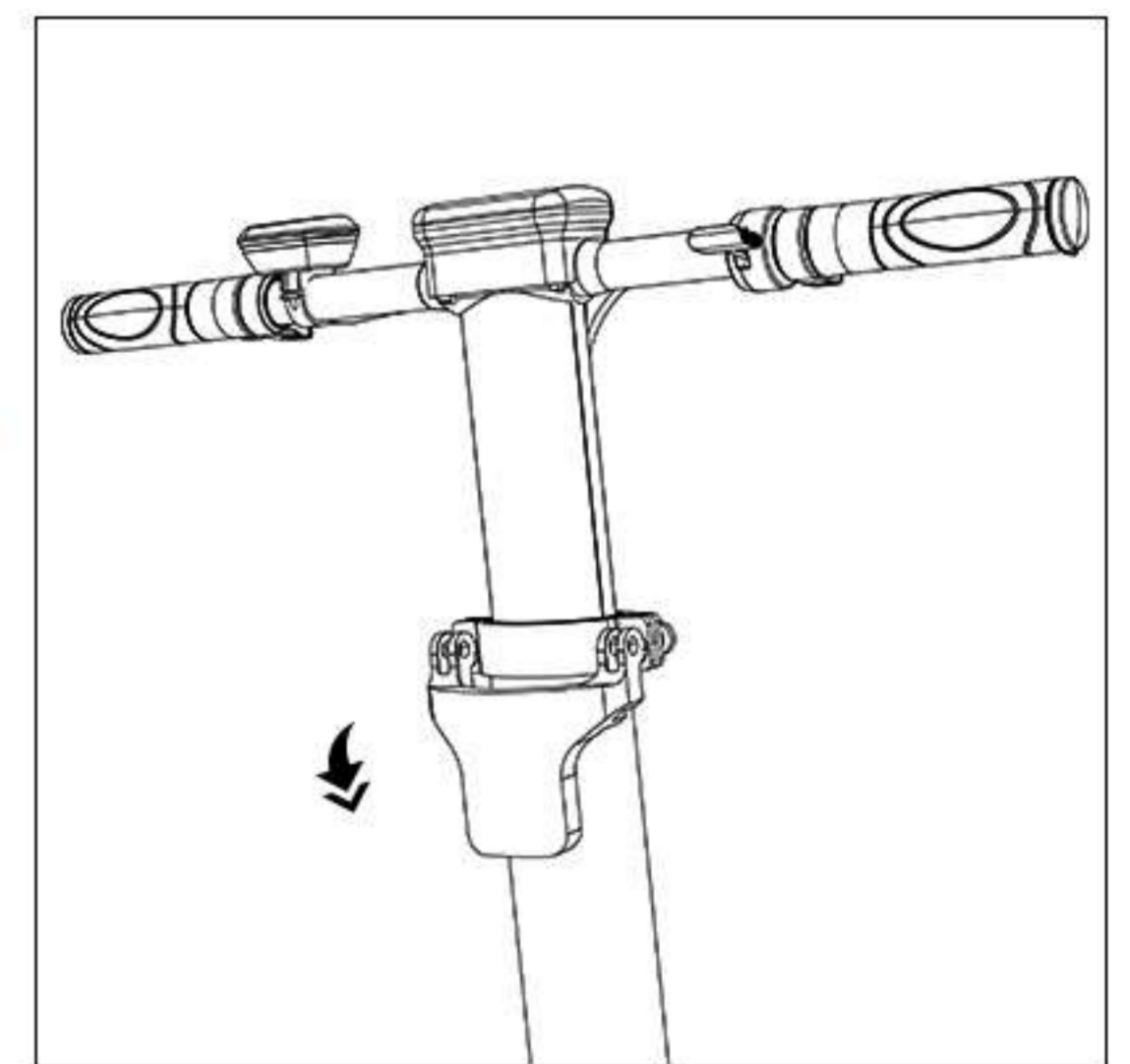

3. And then push to close the quick-release lever.



## HOW TO CHARGE

G-Force provides you with both whole bike charging and external battery charging for your convenience to choose.



### Whole E-Scooter charging mode:

You can plug the charging plug into the body charging port and charge the E-Scooter directly.

•



### CHARGING SAFETY

- Do not use a charger other than G-Force to charge the E-Scooter.
- When you receive the E-Scooter, please charge the battery for the first time in time to ensure that the battery is fully charged when you ride it for the first time.
- Do not leave the battery unattended while charging.
- Avoid charging the battery at too high a temperature.
- Make sure there are no flammable objects around when charging.

### Battery Safety:

- ⊘ If you find the battery is damaged, leaking, discolored, etc., please do not charge the battery.
- ⊘ When storing the battery, be sure to keep it away from heat sources and avoid direct sunlight.
- ⊘ Do not immerse the battery in any liquid.
- ⊘ Do not force the battery to remove, follow the instruction manual into the removal of the battery.
- ⊘ Battery charging time may increase depending on the time of use.
- ⊘ If the battery fails to charge, stop charging immediately.

### Caution:

Be careful when charging, misuse will lead to property damage and personal injury

When your batteries are no longer in use, dispose of your batteries according to your local state regulations. Disposal regulations for lithium batteries vary from state to state, so it is important to know your local government's regulations. Lithium batteries should not be placed with regular trash.



# INSTRUMENT INTRODUCTION

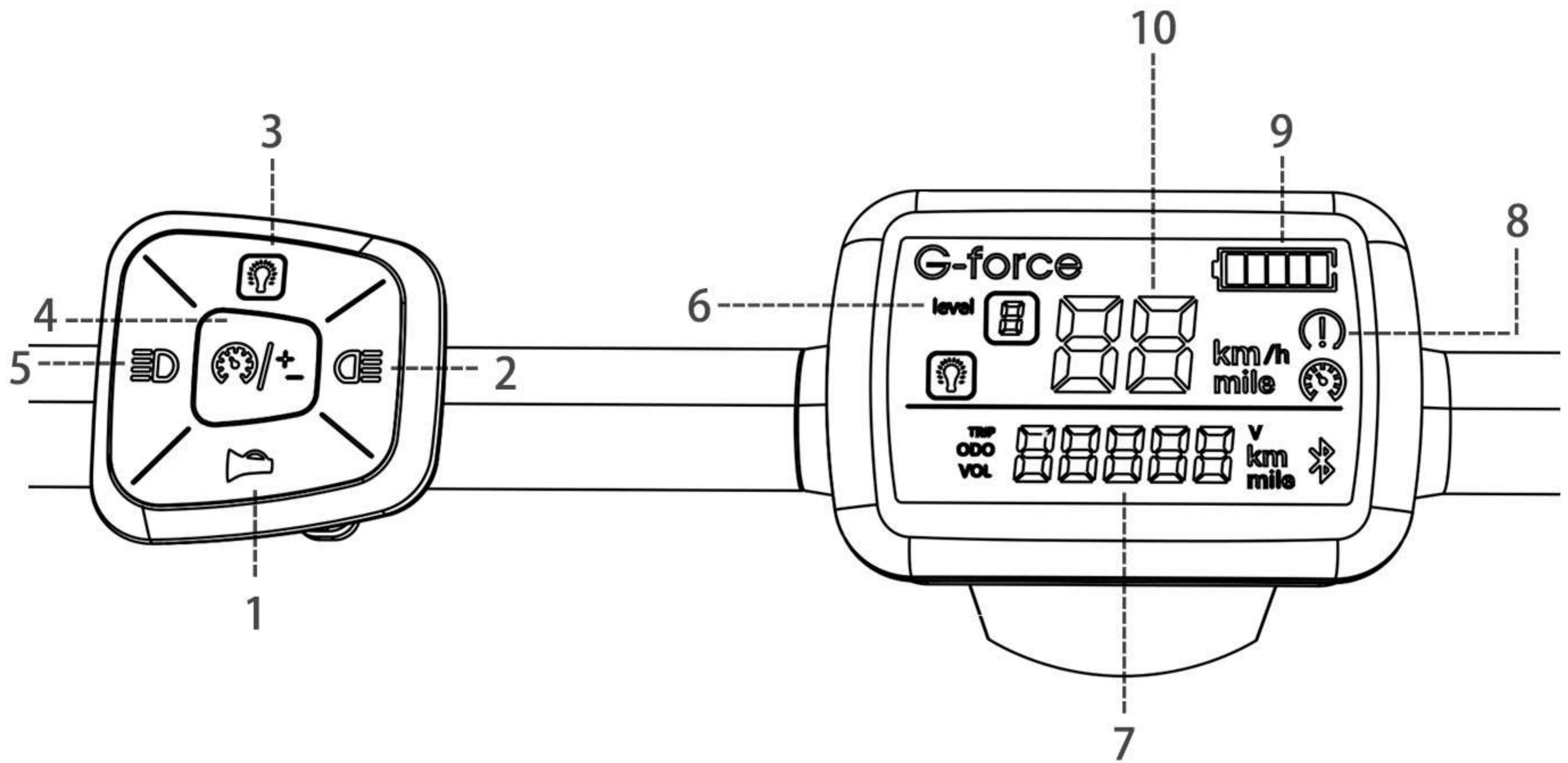

- |    |   |                                    |    |               |     |               |
|----|---|------------------------------------|----|---------------|-----|---------------|
| 1. |  | Horn                               | 6. | Gear Display  | 9.  | Battery Level |
| 2. |  | Right turn signal                  | 7. | Range         | 10. | Speed         |
| 3. |  | Headlight                          | 8. | Fault Warning |     |               |
| 4. |  | On/Off,<br>Up-shift and down-shift |    |               |     |               |
| 5. |  | Left turn signal                   |    |               |     |               |



Please do not modify the instrument parameters that are not explained in this manual, otherwise it may not be able to ride properly.



## TURN THE SCOOTER ON/OFF

### Turn on the meter

1. Press and hold the “” button (in the middle) to turn the scooter on / off.

Note : that if you short press the “” button, the Daytime Running Lights (DRL) will light up for a sec instead of the LCD display.

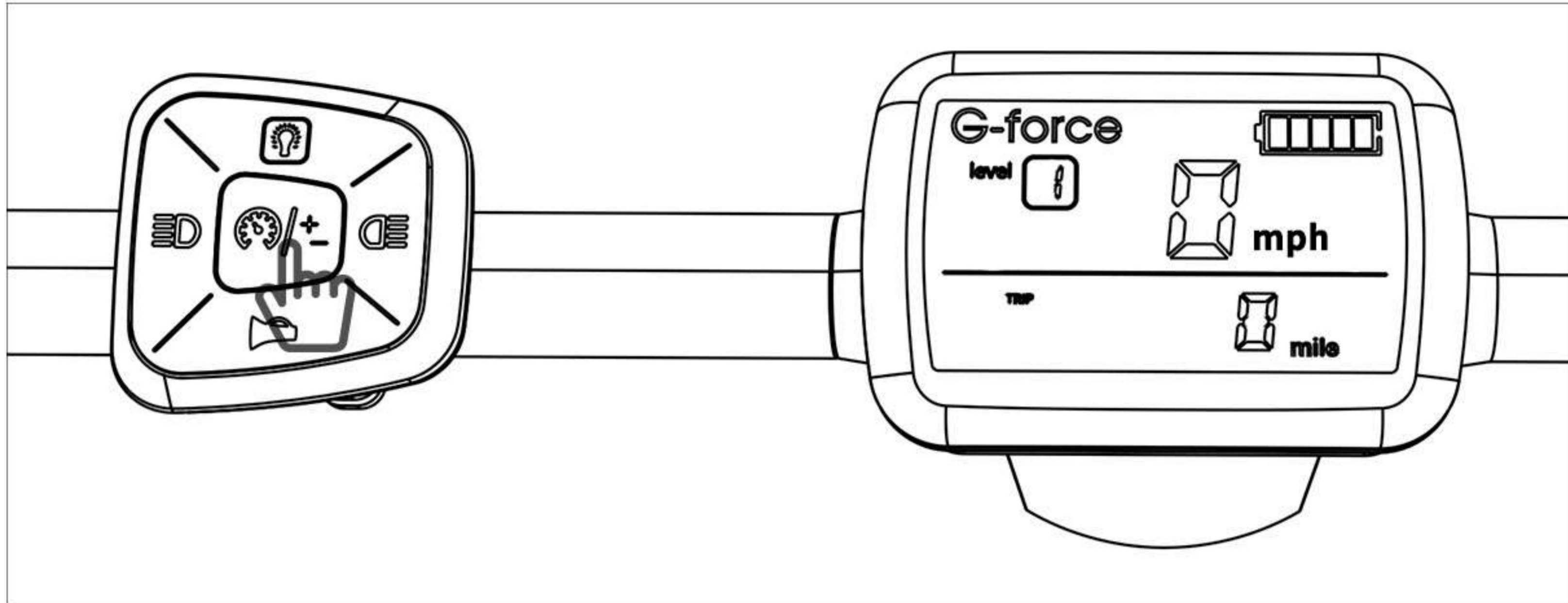

### Off Gauge

1. Press and hold the “” button (in the middle) to turn the scooter on / off.

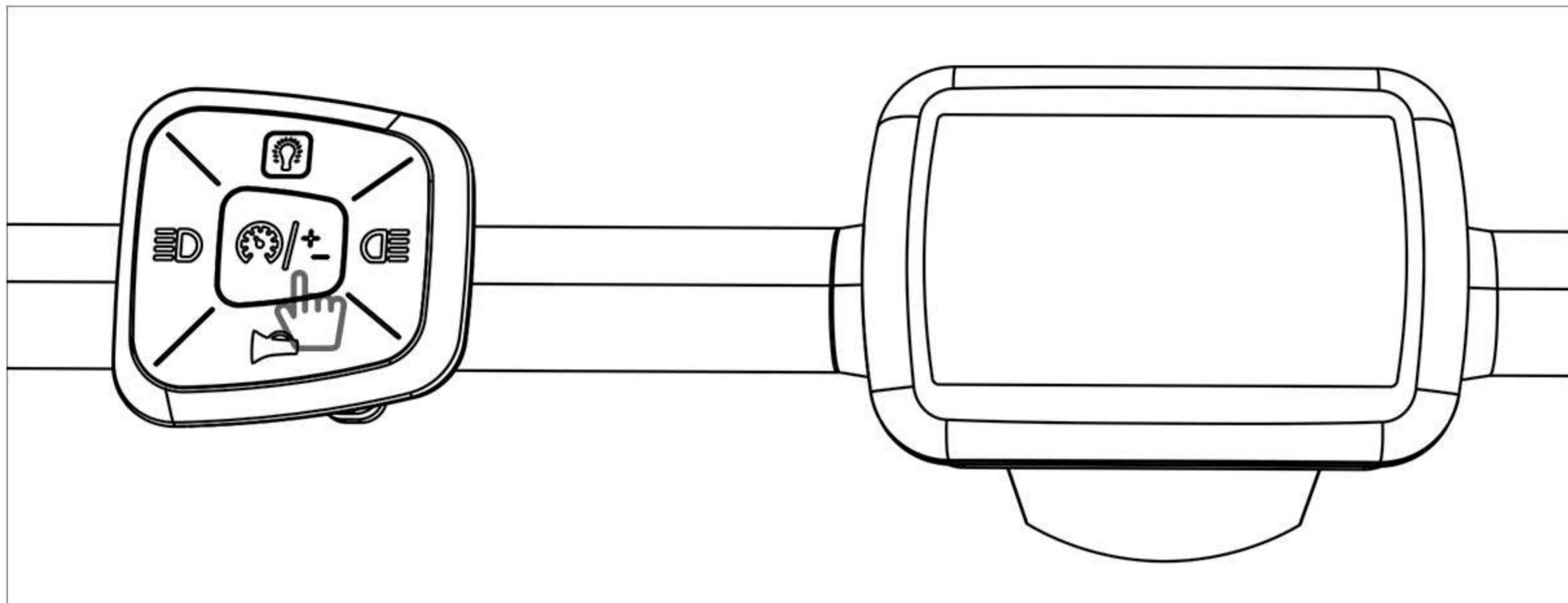

Note: Only the key can activate the power of E-Scooter. This design is to prevent your electric bike from being ridden directly by others when parked on the roadside.

## UPSHIFT/DOWNSHIFT

Short press the middle button to toggle through Gear 1, Gear 2, and Gear 3 (i.e. varying the power output to increase or reduce the speed).

Gear 1 is shown by default when the LCD display is on. Gear 3 indicates the scooter will perform with maximum output (i.e. the max speed).



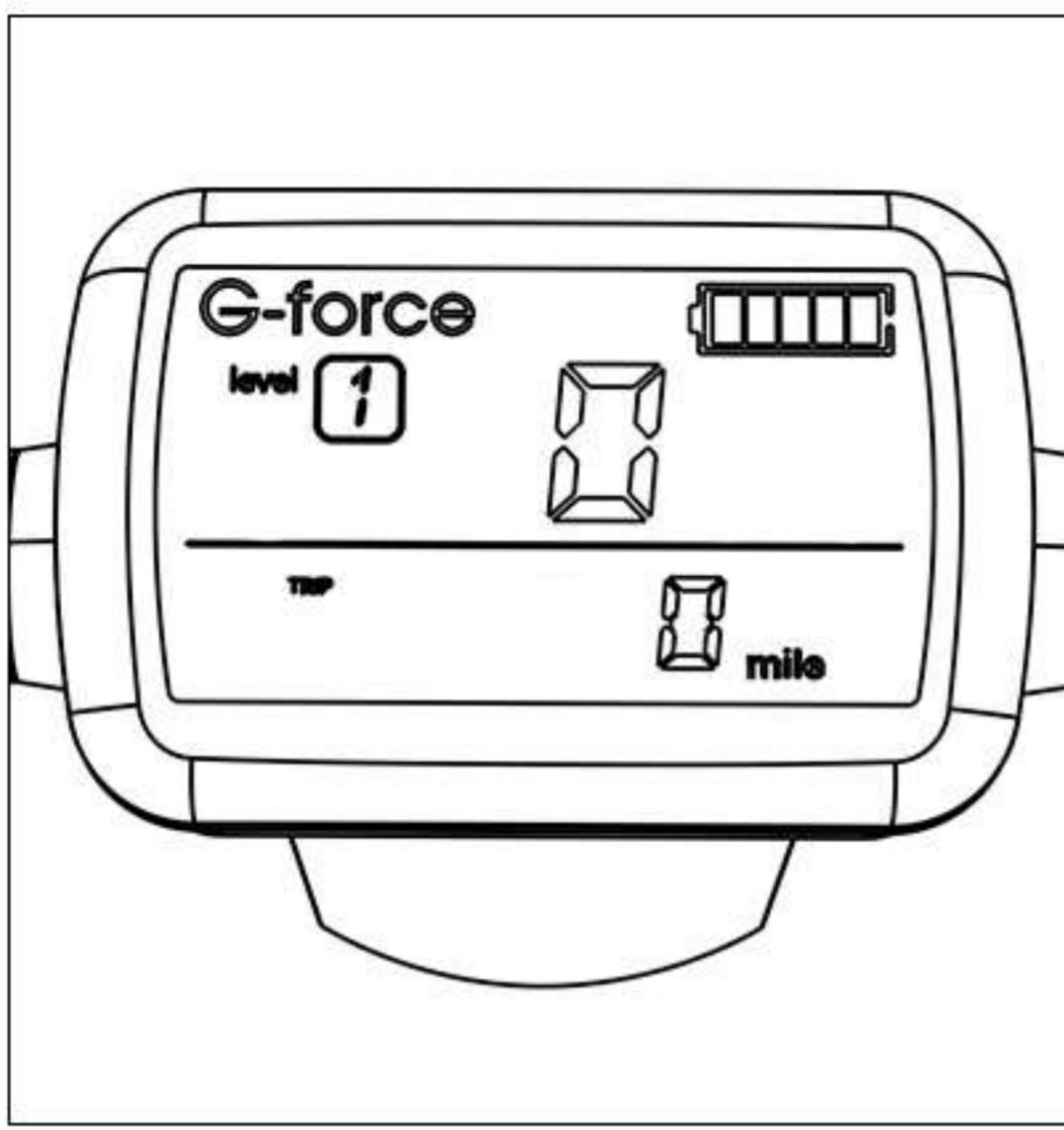

Lowest power

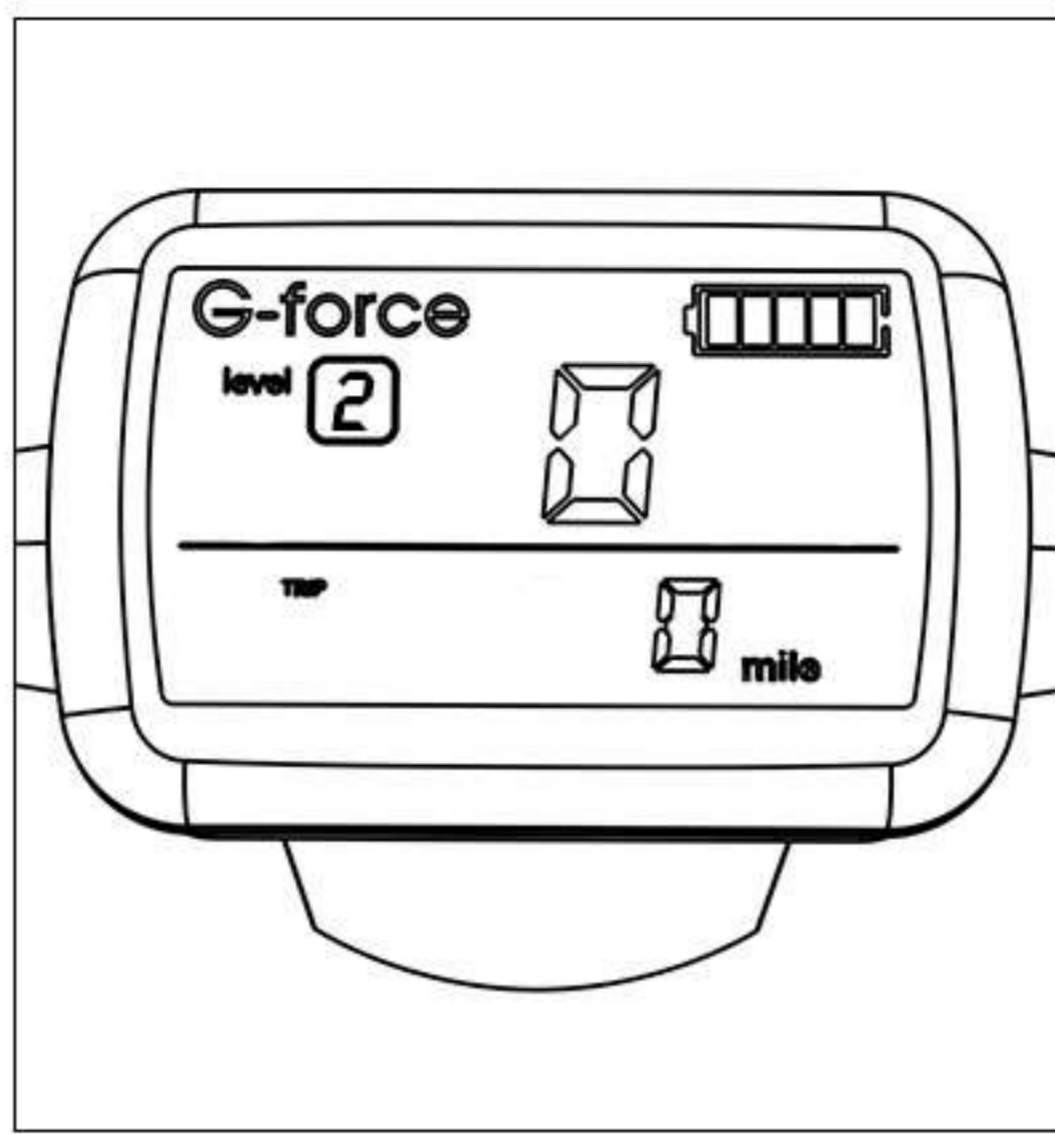

2nd gear power

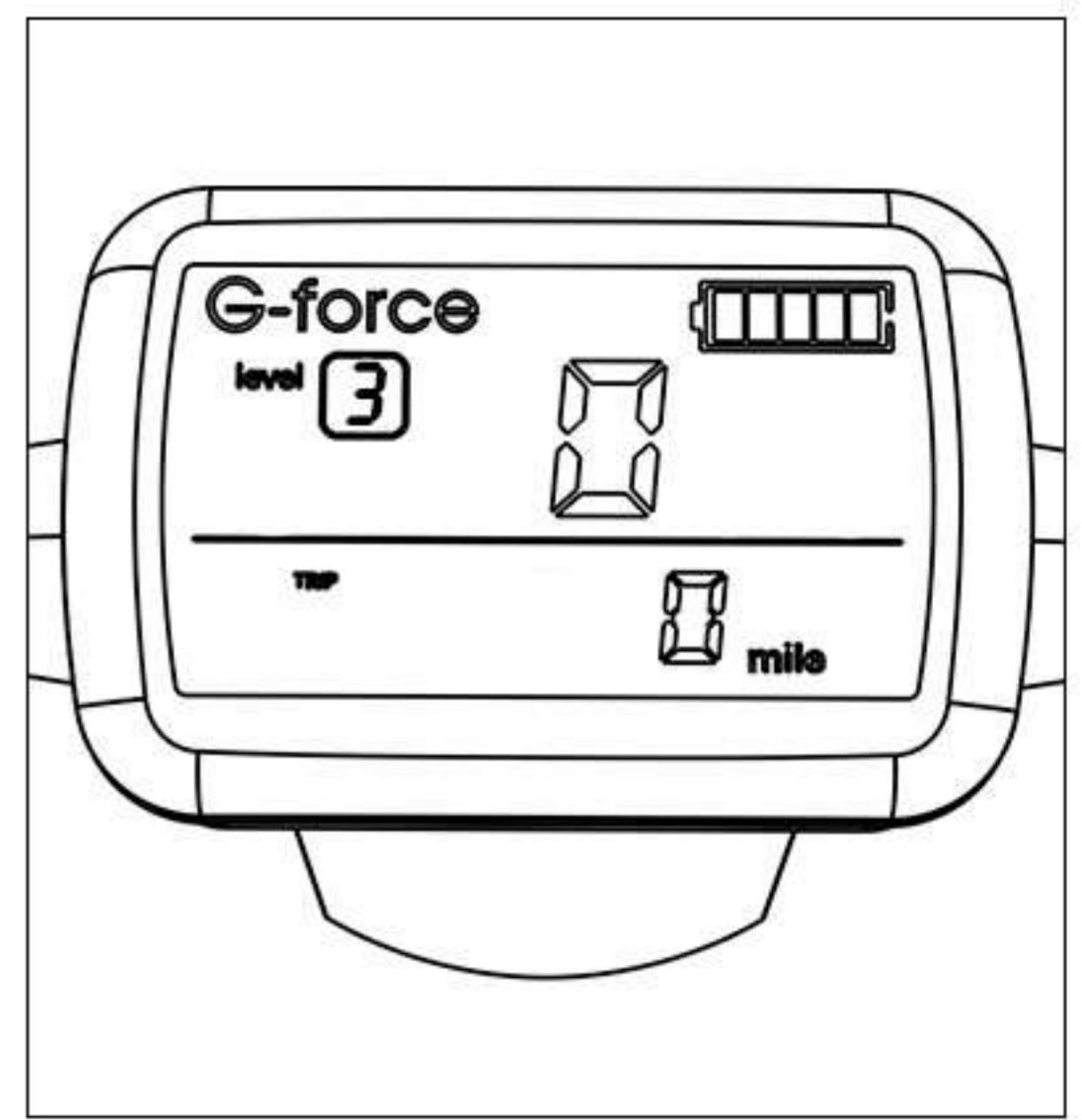

Highest Power

## LIGHTING SYSTEM

1. Press the “” button on the top to turn the front light (not the DRL lights) on / off.

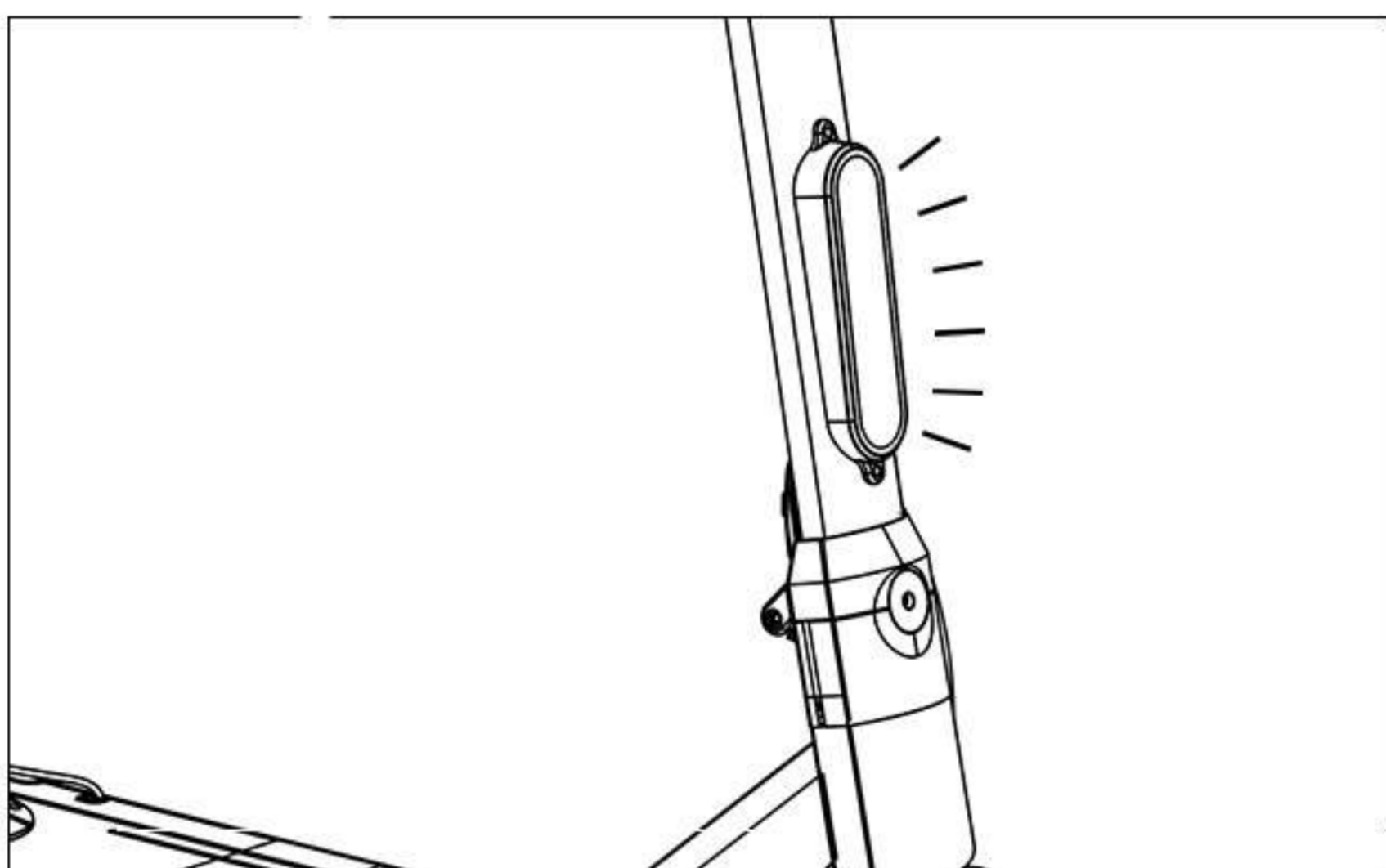
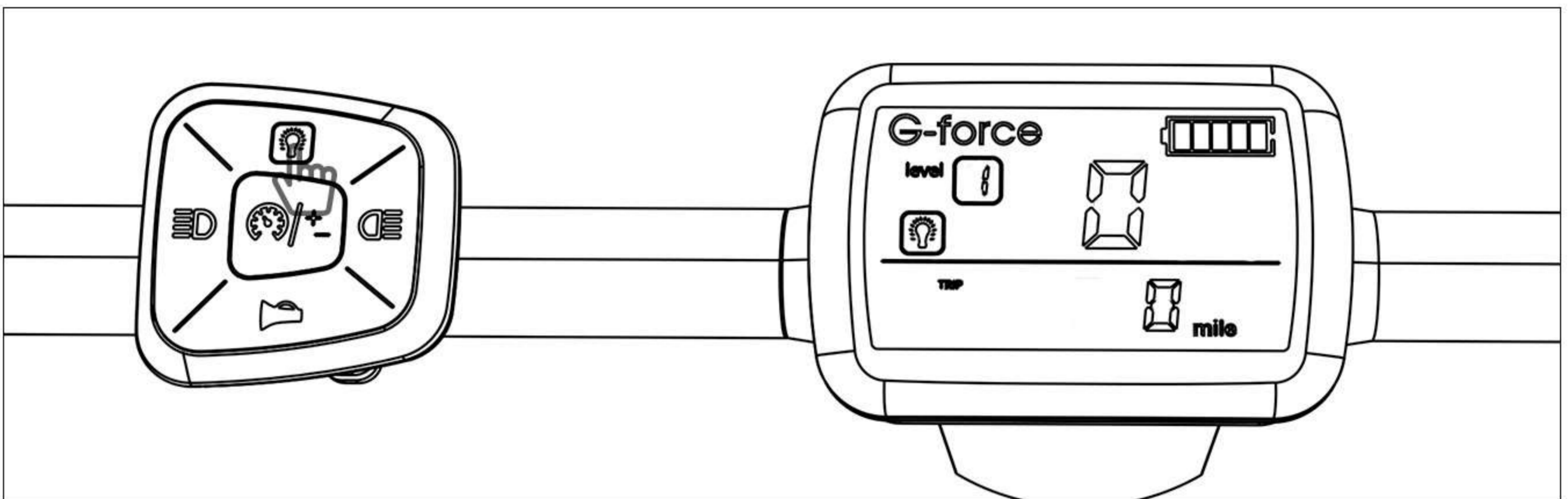

on

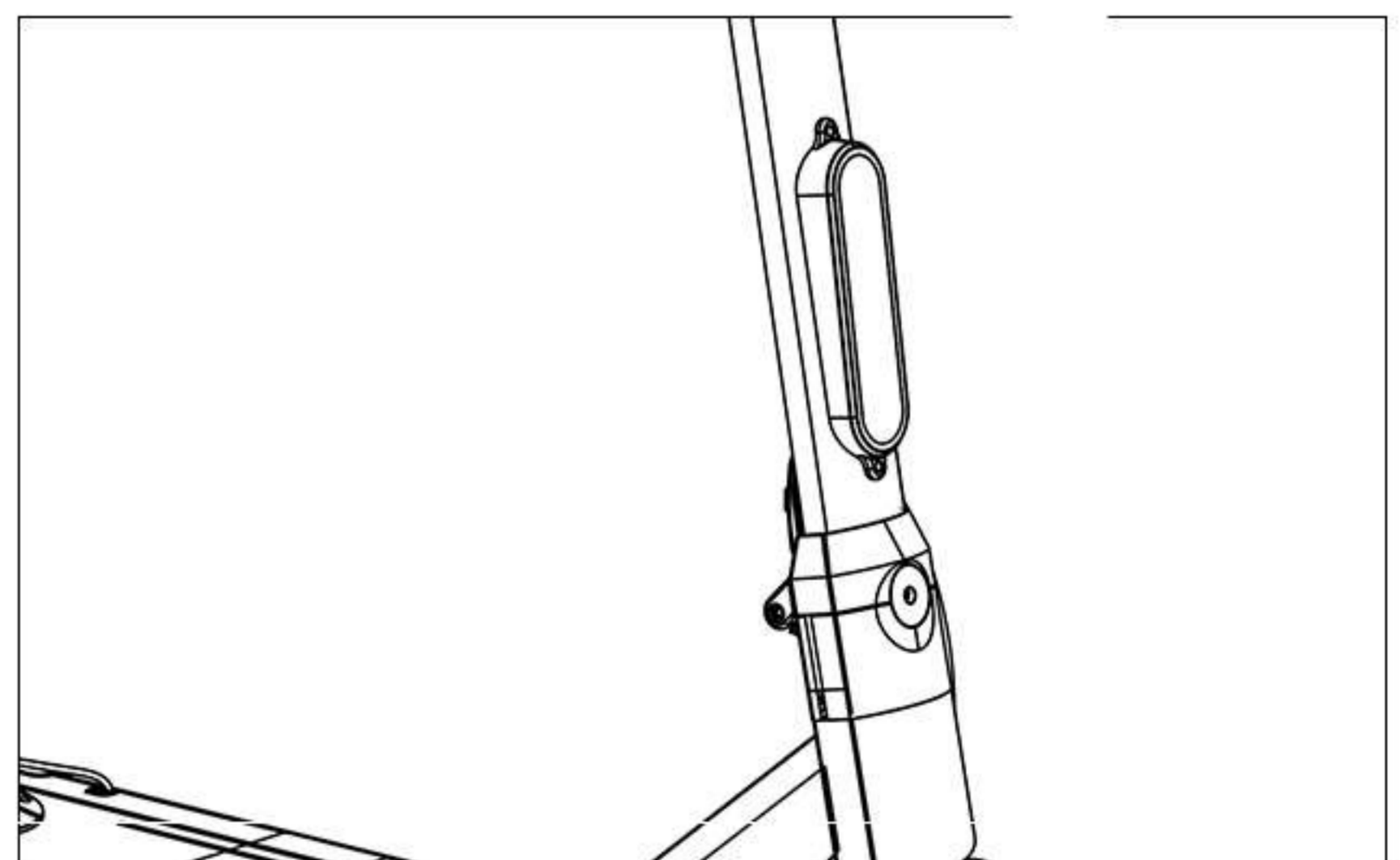

off

2. Press the left button to turn on/off the left-turn signal. The rear left light will flash to indicate a turn to left.

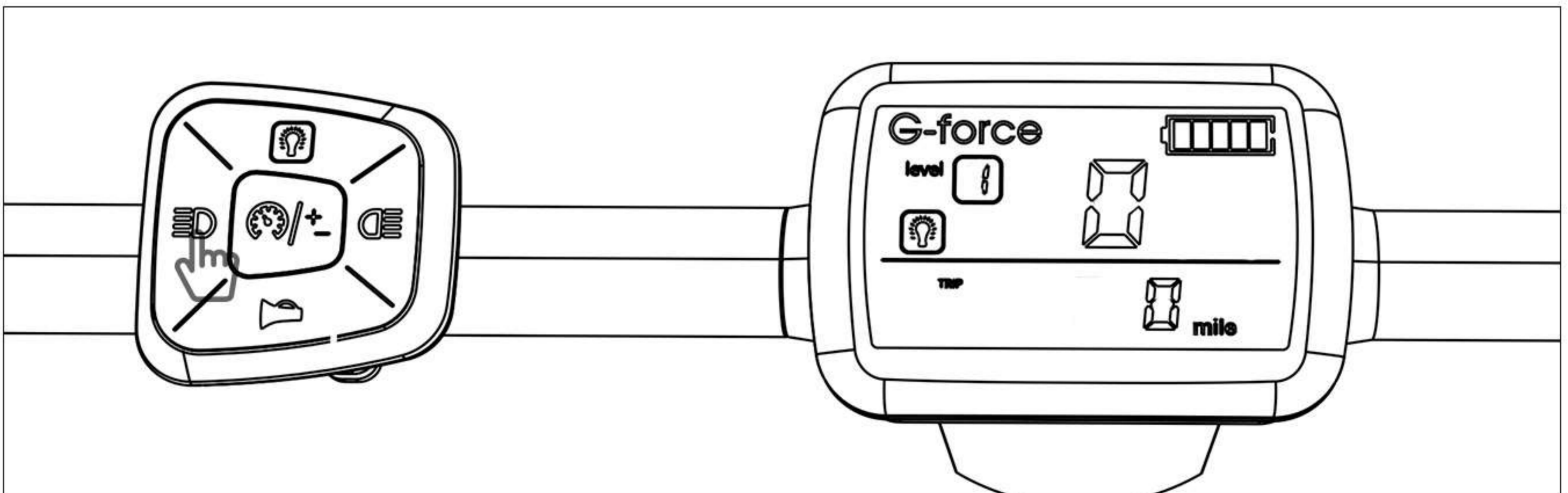



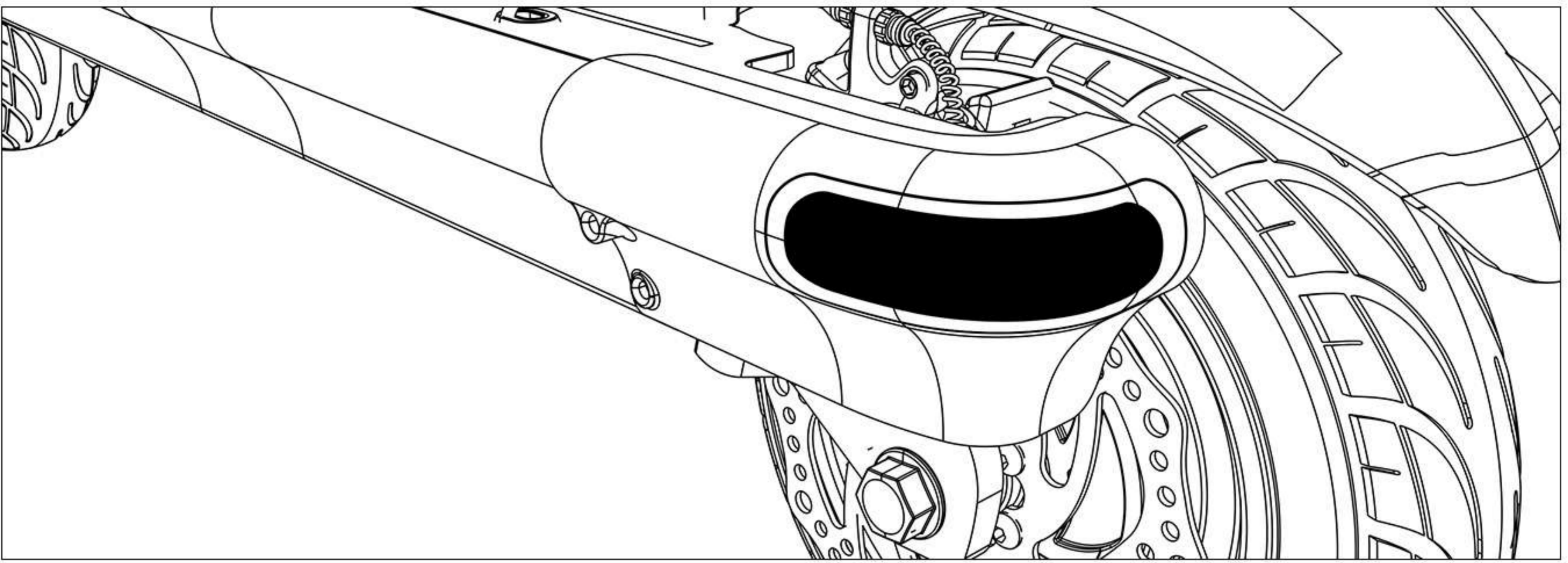

3. Press the right button to turn on/off the right-turn signal.

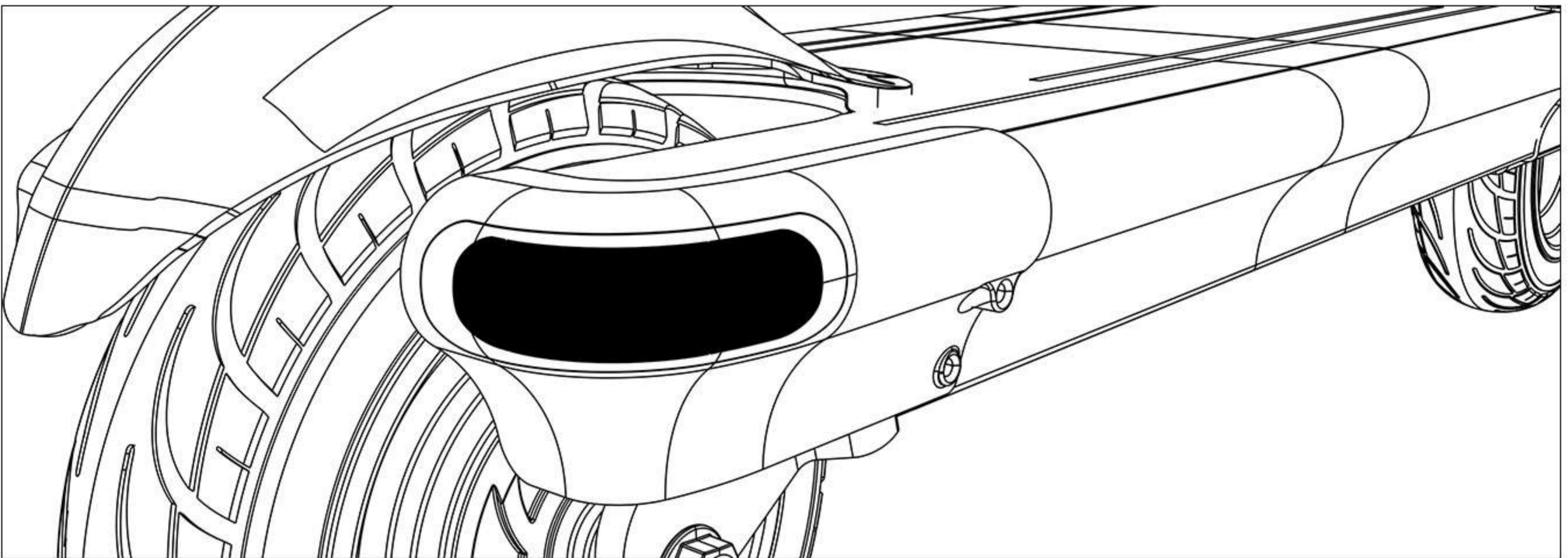
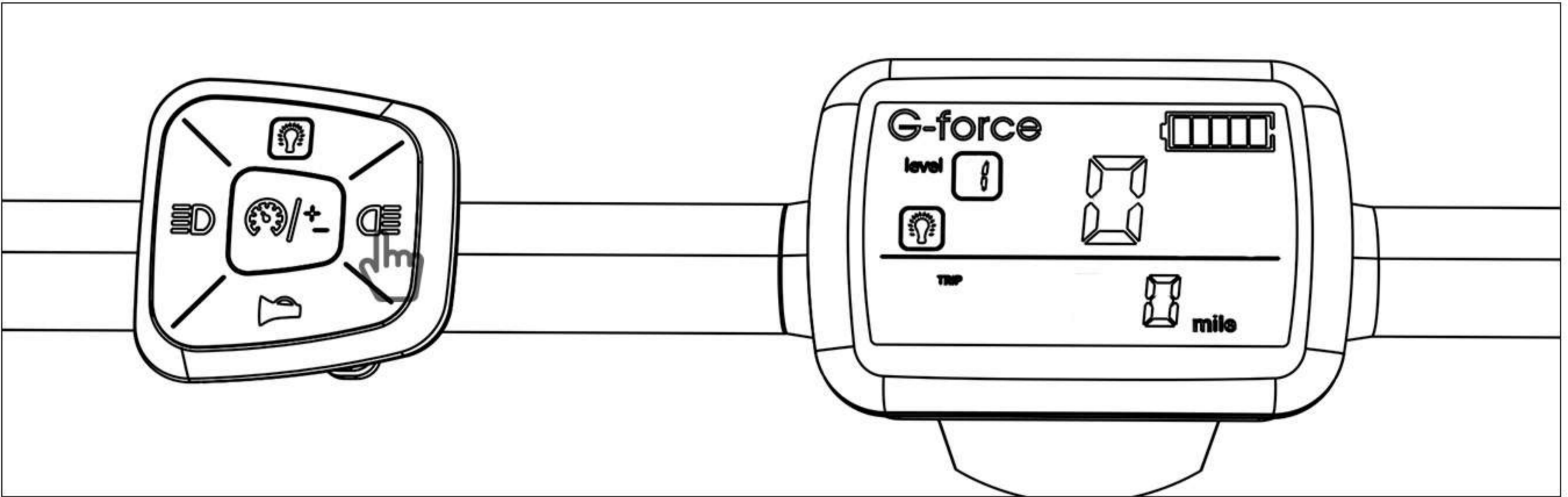

3. The brake warning lights will only come on when either of the brake levers is engaged.  
Note: The brake lights on both sides light up to warn others that you're slowing down. Lights out once you let off the brake levers.

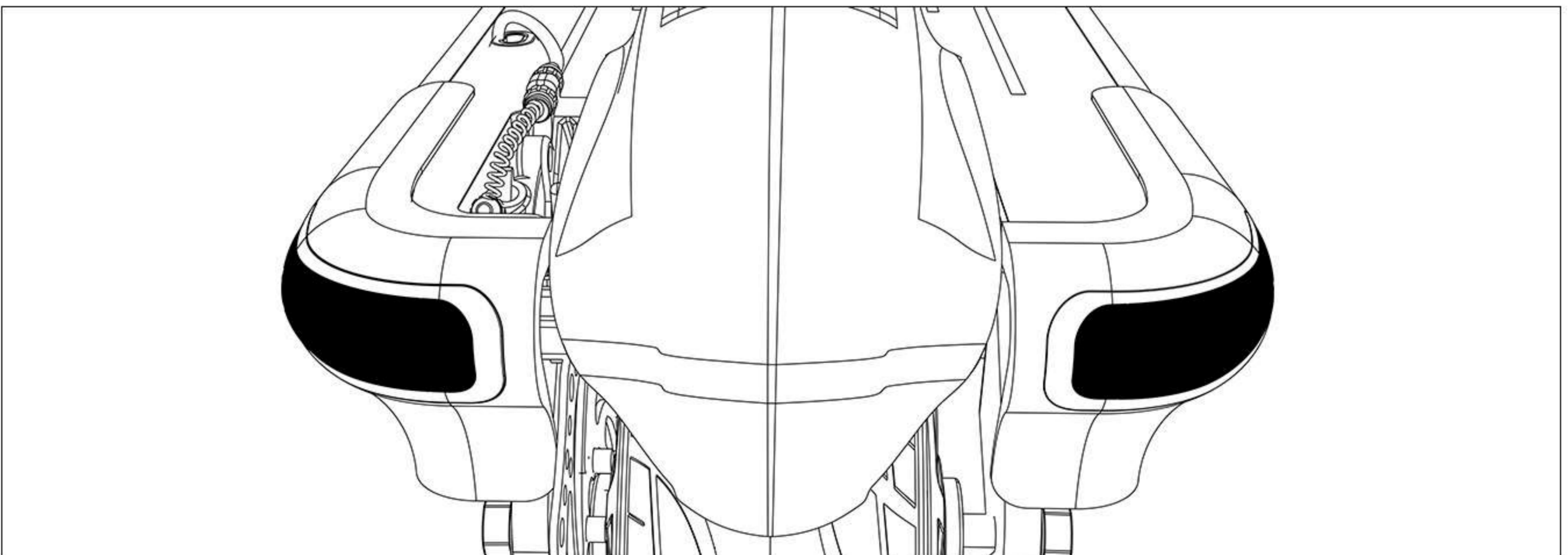



## **OPERATING SAFETY**

Before riding the scooter for the first time, ensure that you have read and understood this manual. Make sure you understand how to turn on and activate the pedal assist and throttle. When first riding the scooter, take care to start slowly in a low level of pedal assist. Take your first ride in a safe area away from cars, other scooters, pedestrians, or other potentially dangerous obstacles. Only move up pedal assist levels when you feel comfortable and you have ample experience riding the scooter. The higher pedal assist levels will accelerate you to higher speeds more quickly. Take care when riding the scooter at any speed. Failure to adhere to warnings and guidelines in this manual can lead to serious harm, injury, or death. Damage sustained by the scooter from failing to follow instructions,

### **Helmets and Local Laws**

Always wear a helmet when riding your E-Scooter. Ensure that the helmet fits your head and is securely tightened down. Before riding, read local laws and comply with all rules relating to riding in your area.

### **Pre-ride Safety Check and Inspection**

Before each ride, make sure to inspect your E-Scooter to ensure there are no loose fasteners or accessories. Make sure to specifically check that both the front and rear axles are secure. Also make sure both the handlebars and the handlebar stem are not loose. Check the tire pressure of both wheels before riding to ensure the tires are inflated to the recommended pressure printed on the side of the tire walls. Pull the brake levers to make sure your brakes are working properly and adjust if necessary. Ensure both your seatpost and handlebar stem are inserted past their minimum insertion points as indicated by the markings on them.

### **Riding in Wet Conditions**

This electric bicycle can withstand light rain and small splashes, but is not designed to be subjected to inclement weather, extremely heavy showers, or submersion in water.



## PRE-RIDE SAFETY CHECK

- 1. Wheel and Handlebar Alignment.

Stand at the front of the scooter, and check if the front wheel is properly centered in the fork and the handlebar is perpendicular to the front wheel and deck.

- 2. Check the Headset and Stem

Check the clamping torque of the stem release lever to see if it is properly fixed. Grasp the grips, lift and press down the handlebar to check if the steering column is securely mounting on the scooter.

- 3. Check the Brakes and Taillight

Check both the front and rear brake to see if the brake engaged normally and smoothly, without squealing. Squeeze either of the brake levers to see if the taillights will come on.

- 4. Check the Cables and Bolts

Check any potentially loose connectors or worn cables. Properly tighten the nuts and bolts for security reasons. Loose bolts can also give rise to serious parts wear and tear.

## ERROR CODES

Error Code	Meaning	Error Code	Meaning
E001	Controller Abnormality	E004	Throttle Abnormality
E002	Communication Abnormality	E005	Brake Abnormality
E003	Motor hall Abnormality	E006	Motor Phase



## WARRANTY

All e-scooters should be operated in accordance with the G-force owner's manual provided with the e-scooter. G-force warrants to the original registered purchaser that e-scooters shall be free from all defects in material and

workmanship for a period of 12 months from the date of shipment, when used in accordance with the owner's manual and for the purpose intended. All other obligations and conditions or liabilities, including obligations for consequential damages, are hereby excluded.

The warranty is nontransferrable and only applies to the original owner. This warranty gives you specific rights and purchasers may also have other rights, which may vary by location. Damage caused by failing to adhere to instructions and warnings issued by G-force is not covered under warranty. Warranty parts will only be shipped within the

Warranty time is calculated from the sales date.

	Accessories	Three Packages	Three Guarantees Failure Type
Electrical parts	Motor	12 months	Free repair of failure within two years
	Controller	12 months	Performance failure
	lithium battery	12 months	Can't charge and discharge
	charger	12 months	Performance failure
	meter	12 months	Malfunction
	Turn handle	3 months	Malfunction
	Brake lever	3 months	No power-off function
	Booster	3 months	No induction capability
Structure	Frame	12 months	There are natural welding, desoldering, and fracture phenomena
	Front fork	12 months	
	Riser	12 months	
	handlebar	6 months	

Accessories sold on [www.g-forcebike.com](http://www.g-forcebike.com) are not covered under warranty (except in cases of shipping damages). Stolen e-scooters are not covered under warranty.



Necessary precautions must be taken to ensure the bike and battery are not exposed to severe weather conditions.

Exposure to very wet, hot, or cold conditions may void the warranty.

We will replace any parts deemed to have been damaged during shipping. Shipping damage must be reported to G-force within 14 days of shipment arrival. This applies to all products including bikes and accessories. You will NOT be refunded as compensation for your time or efforts replacing damaged parts. Replacement parts will not be sent until photographic evidence has been provided to G-force. G-force may request additional documentation (such as video) to assist with accurately diagnosing the problem and processing the warranty claim. Most warranty parts are fulfilled 1-10 business days after the request is put into our system by a customer service representative. Warranty parts are sent using USPS First Class, FedEx Express, or FedEx Ground depending on the size of the part. Warranty parts will not be expedited. Items including the chain, tires, wheels, tubes, battery handle, brake pads, cables and housing, grips, and spokes are considered wear items.

These items wear down with normal use and are not covered under warranty. You are responsible for replacing and maintaining these wear items. Any unauthorized alterations or repairs are not covered and may void this warranty. For warranty services, please contact G-force online support by email at [support@g-forcebike.com](mailto:support@g-forcebike.com). Bikes or parts returned without proper documentation may result in delayed service or denied warranty coverage. Warranty return shipping costs along with duties and taxes are the responsibility of the claimant.



## DISCLAIMER

Riding any kind of bicycle comes with inherent risks and dangers that cannot be predicted or avoided. These dangers could result in a serious accident, injury, or death of the rider. It is the sole responsibility of the rider to become properly educated and prepared to ride safely. Once in possession of the bike, G-force strongly encourages and recommends that all customers have a certified and reputable bicycle mechanic complete a full inspection of each component on the bicycle to ensure it is safe for operation. G-force makes no claims or guarantees that the brakes, battery, frame, motor, motor controller, LCD display, electrical cables, electrical cable housings, fasteners, grips, fork, stem, shifters, headset, seatpost, seatpost clamp, handlebar stem clamp, saddle, wheel hubs, handlebars, spokes, rims, tires, tubes, derailleur, freewheel, cassette, throttle, kickstand, lights, reflectors, hardware, bottom bracket, or any other part or accessory, will be properly secured and adjusted upon arrival. Before every ride fully inspect your bicycle to ensure everything is secured and adjusted properly. Under no circumstances is G-force responsible for any damage resulting from damaged, defective, or improperly secured parts. This includes, but is not limited to, damage to personal property, personal injury, or death.