

Respiratory protection masks

SPIREOR® folded range



INNOVATION
Patented



NHS APPROVED SUPPLIER



FFP1

FFP2

FFP3

Type1R Type2R



SPIREOR®

21st technology to achieve real comfortable protective mask

The **SPIREOR®** range of masks, a Valmy-patented innovation, offers a new dimension to protection: when breathing in and breathing out. **SPIREOR®**, designed with high-tech fibres, offers you optimal protection and unparalleled wearing comfort. Ultra-light, ergonomic, hypoallergenic, fitted with an adjustable nose piece, **SPIREOR®**, greatly reduces the breathing efforts required. For intensive use, for prolonged activities. **SPIREOR®**, considerably reduces the breathing effort required and offers a bacterial efficiency of filtration close to 100% for use in a hospital environment in all at risk departments.

Value-Added from Valmy

- Unrivalled respiratory comfort: valve is no longer required
- Ultra-light, soft, folded
- Intensive use, prolonged activities
- Colour code to show level of protection
- Dispenser box



Breathe easy, we've got you protected

> To find out more, download our Healthcare catalogue at www.valmy.eu

Product Specifications

- Measurements - 227 x 98 mm.
- Thickness: 2 mm.
- Weight: less than 6 g.
- Single use.
- Non woven.
- Hypoallergenic & soft.
- Colour - white.
- Dual hard wearing elastic straps.
- Adjustable nose piece.
- Individually wrapped for hygiene.
- Lifetime: 5 years from manufacture date.

Material Specifications

- Filter media: Polypropylene.
- Ear loop: Polypropylene, Polyamide, Elastane.
- Nose piece: Steel & Polypropylene.

Approvals











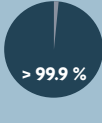
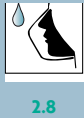

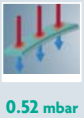
- Logo and legal mentions printed on the mask.
- CE marking in conformity with standards EN 149:2001 + A1:2009 and EN 14 683.

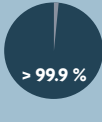
Standards

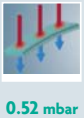
- Our SPIREOR® masks meet basic safety requirements laid down by the Council Directive 89/686/EEC. They meet all relevant European Standards. EN 149 : 2001 + A1 : 2009 by a notified body. Classification by three filtration levels : FFP1 – FFP2 – FFP3.
- Our testing and notified laboratory has given us the « IC » label : this means that our quality management system is above the standards requirements ; our products offer more quality and more reliability that what is required by EN 149:2001 + A1:2009 standard.

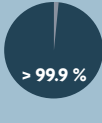
FFP1 Anti-contamination **FFP2** Anti-virus (avian flu, SRAS, tuberculosis), antipollution, anti-allergenic. **FFP3** Anti-virus (infection respiratory pathogens), anti-bacterial (legionella).

D Masks tested against dolomite dust. Results of the resistance test to the clogging-up with dolomite dust prove that our masks filter and resist to the finest dusts.

Ref.	EN 14 683 : 2006			EN 149 : 2001 + A1 : 2009			Class
	BFE (%)*	DELTA P (mm H ₂ O/cm ²)	Class	Media filter penetration* (paraffin oil)	Breathing resistance inhalation 95 L/min	Breathing resistance exhalation 160 L/min	
VSP 152TF	 > 99.9 %	 2.8	TYP 1 R & TYP 2 R	 1.0 % (for 20.0 permitted)	 0.52 mbar (for 2.1 permitted)	 0.90 mbar (for 3.0 permitted)	FFP1 D
VSP 252TF	 > 99.9 %	 2.8	TYP 1 R & TYP 2 R	 1.0 % (for 6.0 permitted)	 0.52 mbar (for 2.4 permitted)	 0.90 mbar (for 3.0 permitted)	FFP2 D
VSP 352TF	 > 99.9 %	 3.6	TYP 1 R & TYP 2 R	 0.15 % (for 1.0 permitted)	 0.75 mbar (for 3.0 permitted)	 1.36 mbar (for 3.0 permitted)	FFP3 D

*Particles size BFE 2.8µ

*Particles size paraffin 0.3µ



Breathe easy, we've got you protected

> To find out more, download our Healthcare catalogue at www.valmy.eu

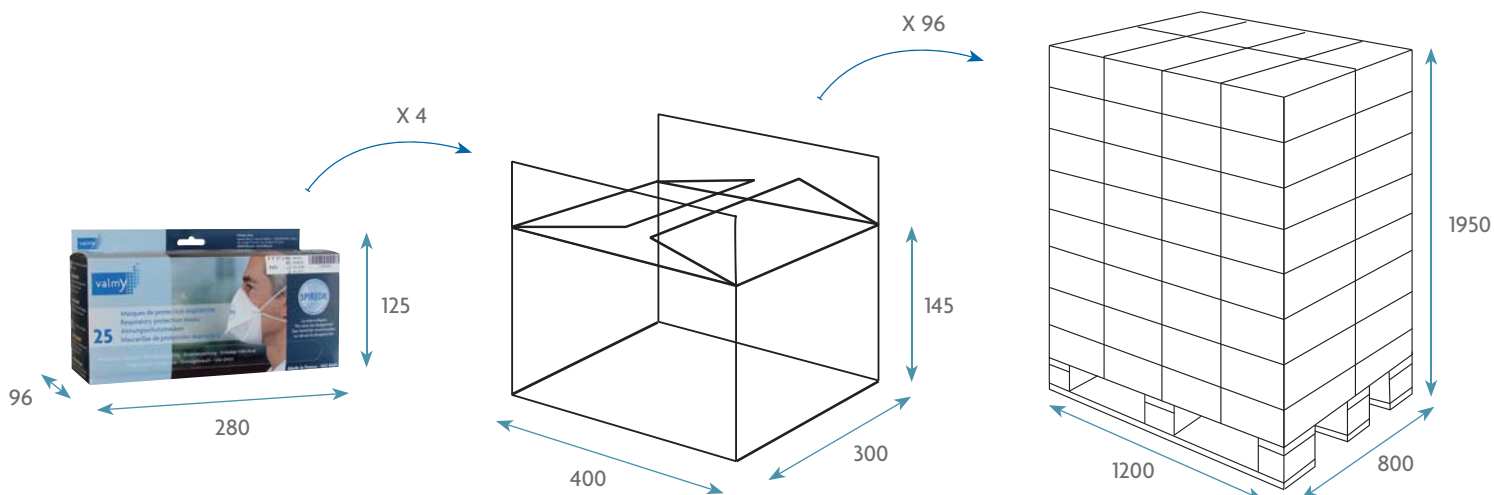

Part Numbers	Description	Class	Masks quantity	Measurements (L x l x H) - mm	Gross weight (Kg)
VSP152F-05C	Case of 4 boxes of 25 masks Spireor®	FFP1	100	400 x 300 x 145	1.40
VSP252F-03C	Case of 4 boxes of 25 masks Spireor®	FFP2	100	400 x 300 x 145	1.40
VSP352TF-07C	Case of 4 boxes of 25 masks Spireor®	FFP3	100	400 x 300 x 145	1.45
VSP152F-05V	Case of 100 masks Spireor®	FFP1	100	400 x 300 x 145	1.00
VSP252F-03V	Case of 100 masks Spireor®	FFP2	100	400 x 300 x 145	1.00
VSP352TF-07V	Case of 100 masks Spireor®	FFP3	100	400 x 300 x 145	1.10

Pallet

Description	Class	Masks quantity	Measurements (L x l x H) - mm	Average gross weight (Kg)
Pallet of 96 cases of 4 boxes of 25 masks Spireor®	FFP1	9600	1200 x 800 x 2000	156,00
Pallet of 96 cases of 4 boxes of 25 masks Spireor®	FFP2	9600	1200 x 800 x 2000	156,00
Pallet of 96 cases of 4 boxes of 25 masks Spireor®	FFP3	9600	1200 x 800 x 2000	161,00
Pallet of 96 cases of 100 masks Spireor®	FFP1	9600	1200 x 800 x 2000	118,00
Pallet of 96 cases of 100 masks Spireor®	FFP2	9600	1200 x 800 x 2000	118,00
Pallet of 96 cases of 100 masks Spireor®	FFP3	9600	1200 x 800 x 2000	127,00



Breathe easy, we've got you protected

Head office, Factory & Export Department

VALMY SAS - Rue Benjamin Franklin
42300 MABLY - FRANCE
Tél. : +33 (0)4 77 23 11 21 - Fax +33 (0)4 77 72 54 57
info@valmy.eu - export@valmy.eu - www.valmy.eu

UK & Ireland Distribution

VALMY SAS Ltd - Units 21 & 23 Scott Road
Off Park Avenue - LUTON - Beds - LU3 3BF
Tel. +44 (0)1582 563600 - Fax +44(0)1582 563323
uk-sales@valmy.eu - www.valmy.eu