

# PROMASTER 159" WALL KIT

---

Installation Guide

[www.sergsupply.com](http://www.sergsupply.com)

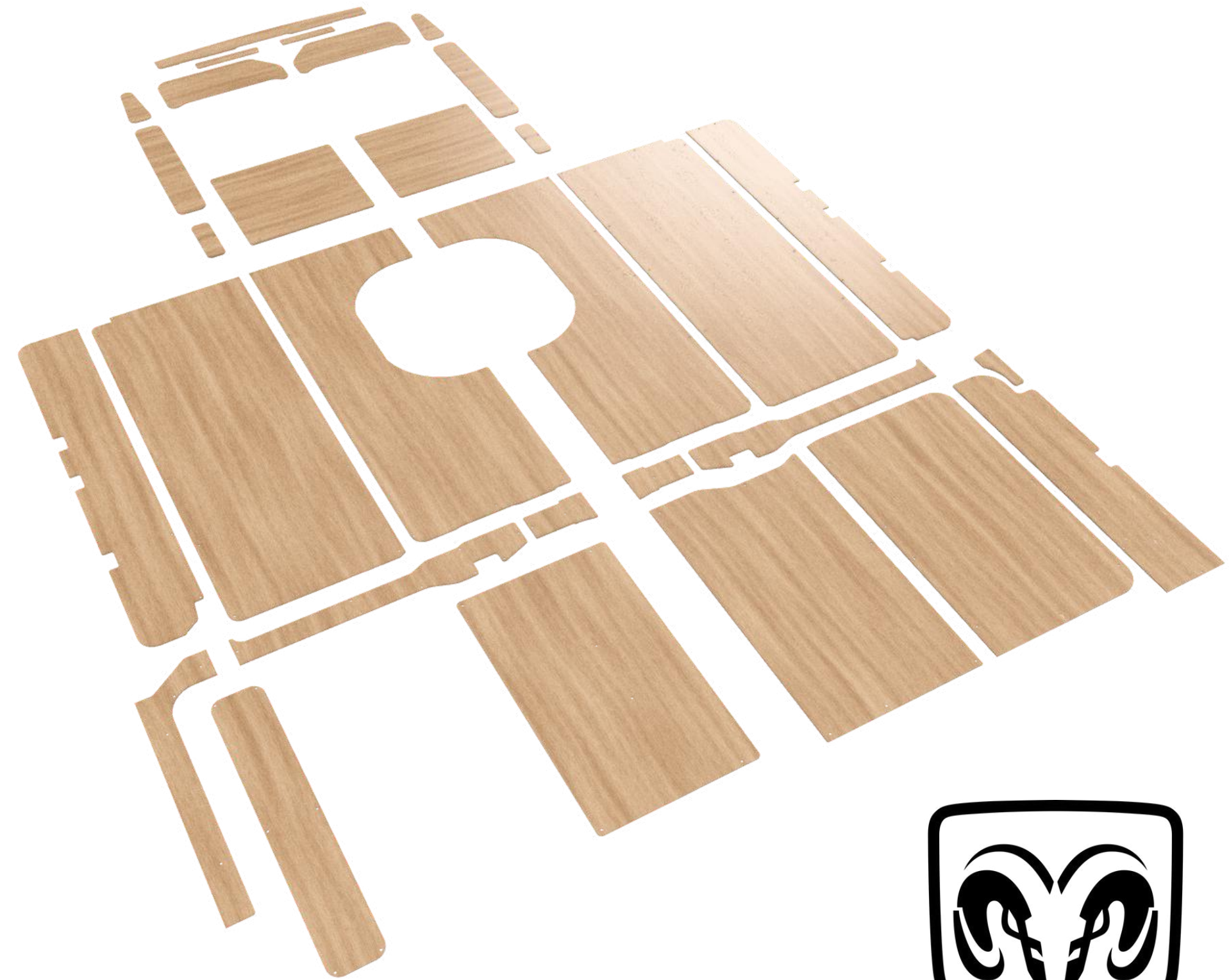

**RAM**

What you will need to get started:

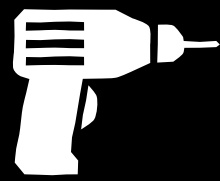

**Power Drill**  
With Phillips Drive

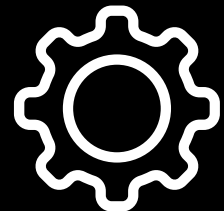

**Rivet Nut Tool**  
With 1/4"-20 Thread Pattern

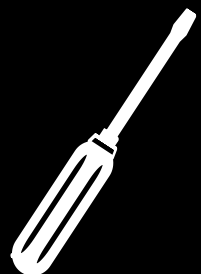

**Screwdriver**  
With Phillips drive

## **Disclaimer!**

This kit must be fastened properly to the walls of the vehicle to avoid damage or injury. You are responsible for ensuring that this kit is fastened using rivet nuts or other fastening method equal in strength. Avoid making large cuts on vehicle partitions or beams as this may weaken the vehicle. You are responsible for ensuring proper wiring and insulation when wiring your build as faulty wiring may create a fire hazard. Any cabinetry or load-bearing components need to be mounted to the vehicle and not to the walls alone.

## What's Included:

- Driver Side Panels
- Passenger Side Panels
- Installation Hardware

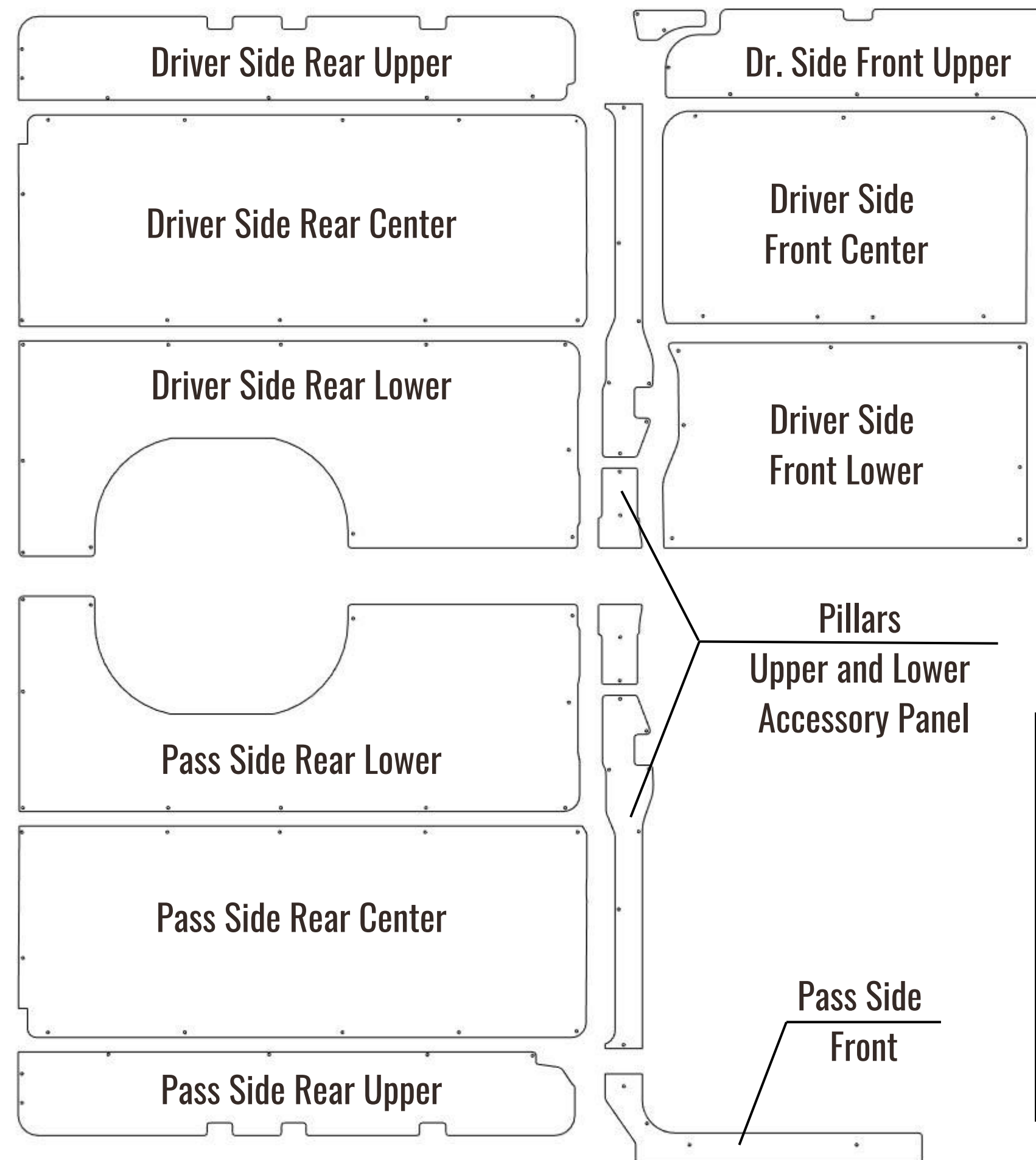

## Slider Door Panels



## Rear Door Panels

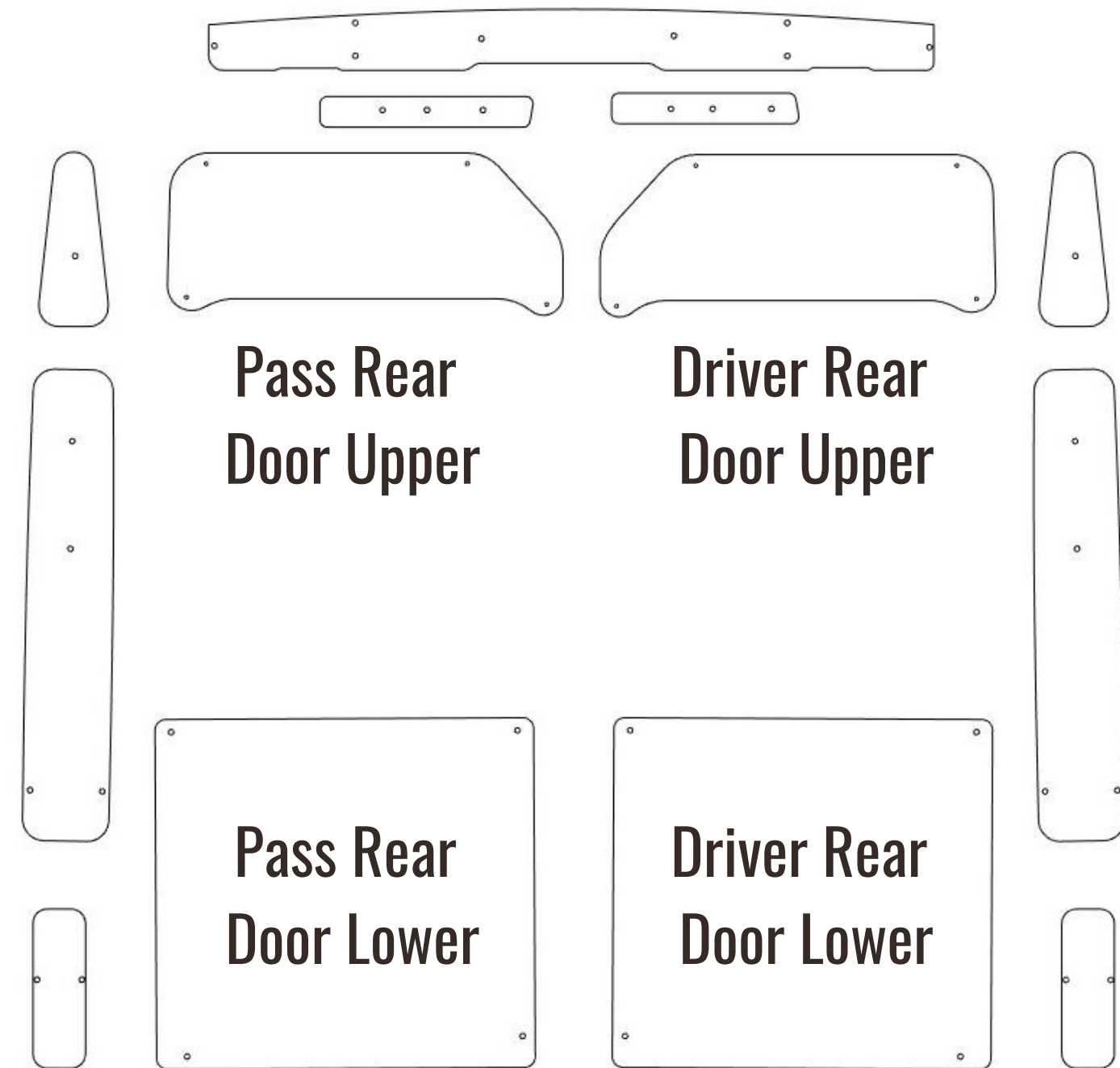

## Pre-Installation Tips

1. Get a helping hand. This installation is dramatically easier with someone to help you out and offer good company.
2. You'll need a power drill, screwdriver with Hex bits, and a drill bit set with assorted bits.
3. **NOT ALL VANS ARE MADE EQUAL!** Sometimes holes differ in exact position from van-to-van. This could be seen as 1-2mm difference in smaller panels and up to 5mm difference in larger panels. You will need to bore out the holes to fit properly in these cases. While you may use the 9mm bit included to widen these holes, generally a **burring Dremel head** is the most effective.
4. The Ram Promaster 159, 159 EXT, and 136 are identical in installation – the difference is only the length of the rear panels.
5. The rear and slider dome lights are not compatible with this kit. Those lights will need to be removed.

# Choosing your Fasteners

- This kit comes standard with self-tappers, but can be installed using rivet nuts as well.
- The predrilled holes in your panels are designed to match with solid stretches of metal in the van with room to shoot and thread self-tappers or rivet nuts.
- You are encouraged to add more holes to the panels if needed.
- We recommend using **Rivet Nuts** as the installation method with process outlined below:
  - Install all wall panels using self tappers throughout the vehicle.
  - Once you're happy with the fit, remove all wall panels.
  - Use a 3/8" bit to bore out all of the self-tapper holes + wall panel holes
  - Use 1/4"-20 rivet nuts + hardware from Serg Supply to install wall panels
- Need rivet nuts + installation hardware? Reach out to us!

## Rivet Nuts & Proper Threading

- Mark the proper holes with a permanent marker all at once before beginning to drill them out to size with the included drill bit.
- Be very careful not to apply too much pressure and keep the drill at a low speed to avoid damaging the outer shell of your vehicle if using any tool other than a Step bit. A drill bit tends to catch the metal and slam the bit into the sidewall of the van if you're not careful.
- Once all holes are drilled out, begin installing the rivet nuts. Be sure that the rivet nut is installed perpendicular to the surface as threading screws in at an angle may cross-thread the rivet nut.

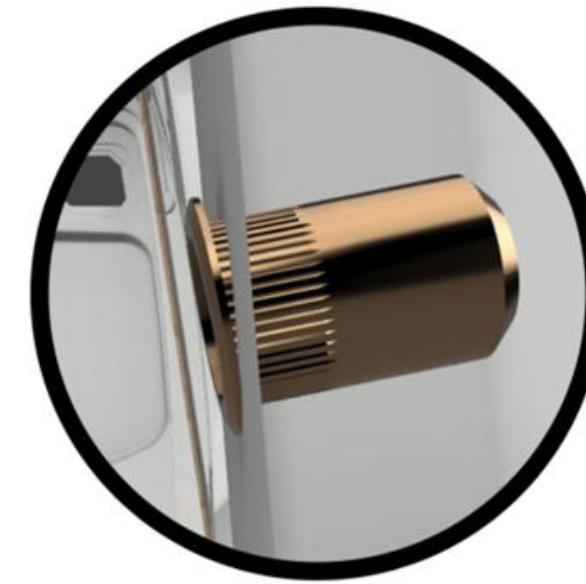

Improper Angle

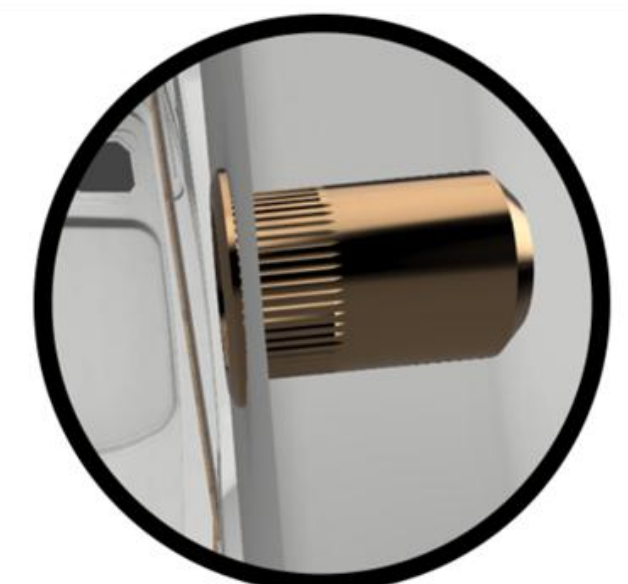

Proper Angle

### **NOTE:**

**Rivet nut size is specifically chosen to match the opening size of the rectangular slots in your ceiling – drilling may not be necessary for beams.**



Improper Angle



Proper Angle

- Take extra care to ensure the screw is threaded straight and not at an angle. Threading the screw at any angle may cross thread the rivet nut.
- Once all rivet nuts are installed, begin threading on your ceiling screws with a screwdriver.  
**Never use power tools to thread machine screws.**
- Always use finish washers when doing final installation. These act to cover any re-sized holes and prevent the screws from loosening over time.
- The panels are designed to fit factory holes throughout the vehicle. Line up the panel up against the area it covers to approximate the holes you'll need to apply rivet nuts into.



# Lower Panels

- Begin with the drive side front lower panel. This is right behind the driver seat.
- The panels are designed to fit factory walls throughout the vehicle. Line up the panel up against the area it covers to approximate the proper position by using the existing frame to line the panels flush to their boundaries.
- Have a helping hand hold the panel perfectly in place.
- Locate the metal-tapping screws included with your kit and begin to shoot in a few screws to hold the panel up. Shoot the screws in the remaining predrilled holes.



## Window Panels

- Hold panels in place and begin with upper screws.
- Ensure the panel aligns with the vehicle's panel boundaries.



## Upper Panels

Upper panels have no fastening points along the top edge, so apply liberal self-tappers along the ends and bottom.

**Note:** The screws are going into a slanted surface. It is highly recommended that you use a drill bit to pilot the holes before shooting the screws in to avoid slipping.

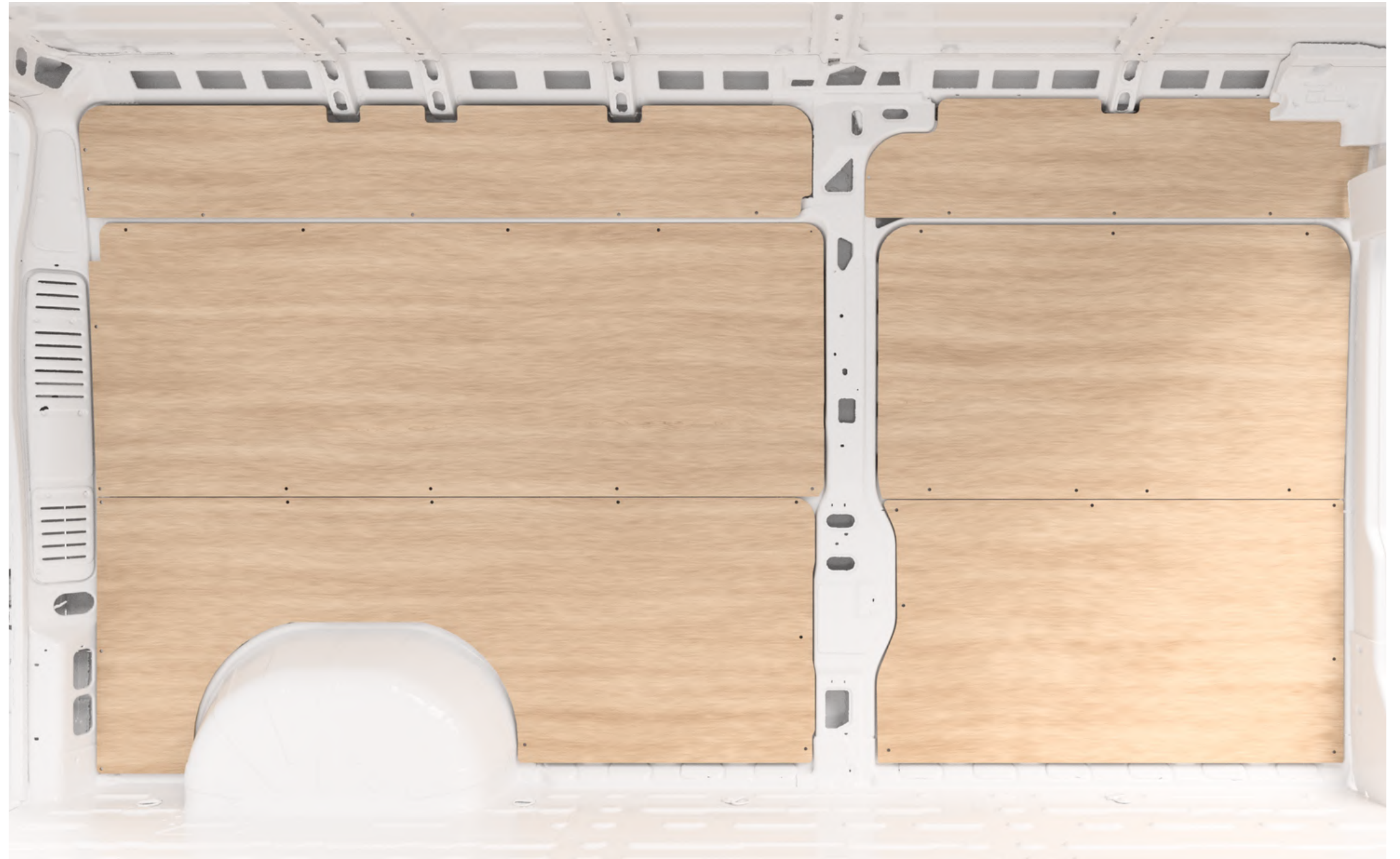

## Pillars

Each of the pillars has an upper and lower accessory panel.

**Note:** The passenger side slider upper cover needs to butt up against the pillar center panel. This panel will hug the curve above the slider door. Do Not use long self-tappers as they'll hit the slider rail.

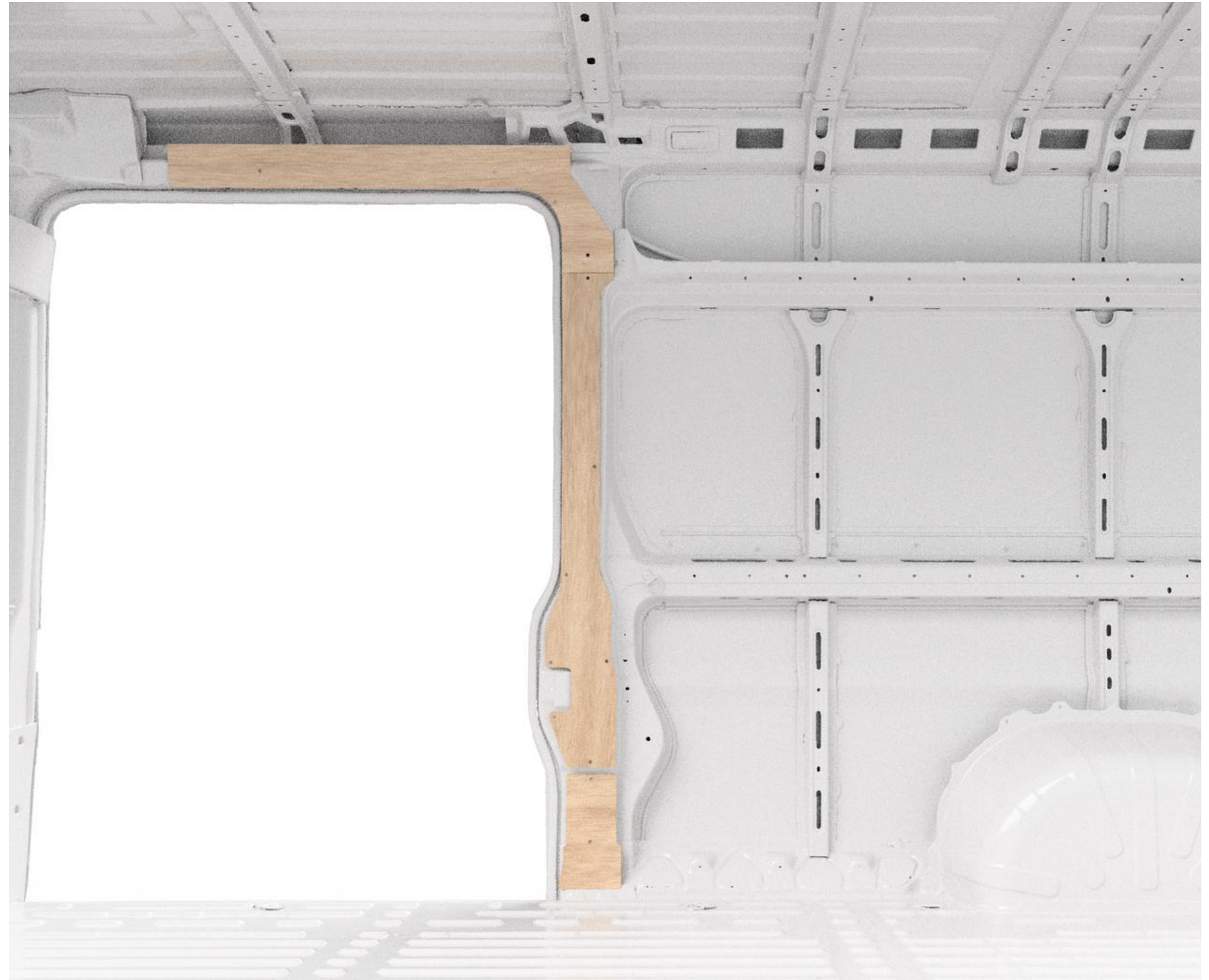

## Rear Doors Panels

- The rear doors have two panels: lower and upper.
- The speaker panels are curved, and the panel will need to be pushed into place. It is recommended to use rivet nuts for the center panel as it has an acute curve and can pull out the self-tappers.
- The cargo area has one cover behind the factory light above and two smaller insulation cover panels. These are optional but recommended.



## Slider Door Panels

- Slider door panel installation is simple and straightforward.
- Align panels and shoot in place.

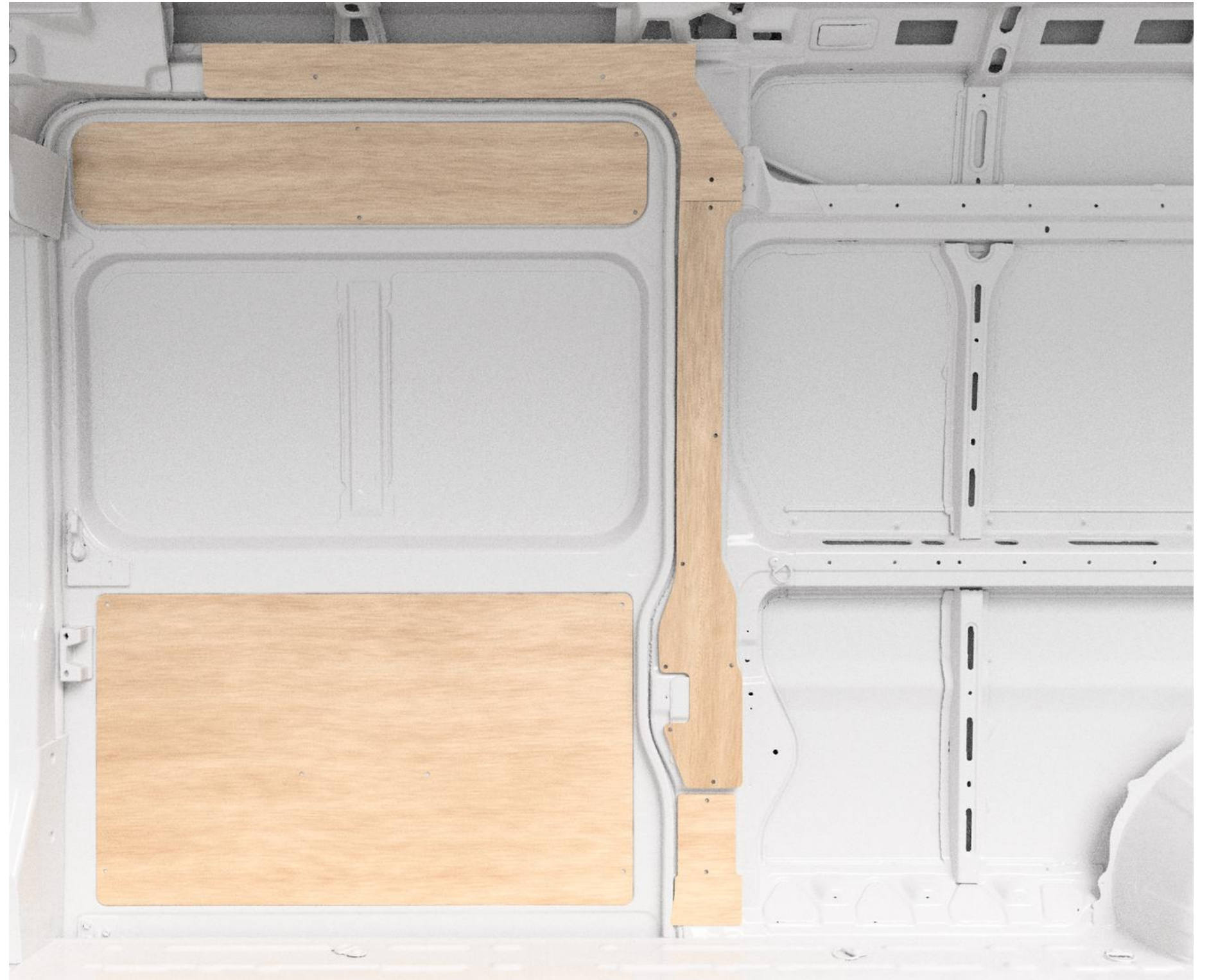

## Exposed Upper Corners

The arched beam mounts holding the ceiling in place pose a problem for covering. Since mounting points are limited, the recommended method for covering is using wood or upholstered paneling. These can be shot directly to our wall/ceiling panels.

## If The Holes Do Not Line Up

As mentioned above, each van has mild variation. If you notice the center of a rivet nut is not centered with the holes, try the following:

- If you can thread the screw on without cross threading, give it a try.
- Loosening all installed screws and moving the panel into position to thread the misaligned screw.
- If there's no way to thread the screw, note the position of the rivet nut relative to the hole.
- If it is just hardly off center, use a burr Dremel bit or drill bit (up to 1/2") to bore out the hole so that it may line up. We've included large finish washers to cover this in case it happens during your install.



## Final Step

Enjoy your kit and go adventure!

Send us a photo or tag us on **Instagram @sergsupply**, we'd love to see your build.