



Countertop Water Dispenser Owner's Manual



RWD-300B

Read & Fully Understand This Owner's Manual Before Using This Machine.

Thank you for purchasing the Royal Sovereign Bottom-Load Water Dispenser, RWD-300B. This manual will provide you with safety information, instructions for optimal use, and proper care and maintenance for your product. Please read this manual carefully before operating.

CONTENTS

SAFETY INSTRUCTIONS.....	3
PRODUCT VIEW.....	4
PRODUCT OPERATION	5
MACHINE MAINTENANCE	8
TROUBLESHOOTING	10
SPECIFICATIONS.....	11
WARRANTY	12

SAFETY INSTRUCTIONS

When using this appliance follow these safety precautions to reduce the risk of fire, electric shock, or injury.

WARNING

1. Keep this appliance away from high temperatures and in a dry and ventilated place.
2. Never install this appliance in the open air or under rain or direct sunlight.
3. For your safety, this appliance should be properly grounded on a level surface indoors.
4. The appliance should be placed near an electrical outlet so that the outlet is easily accessible.
5. Make sure the voltage meets the appliance's electricity requirements (110-120V/ 60Hz).
6. Do not operate if the electrical plug or power cord is damaged.
7. Only plug the appliance into an exclusive properly installed three prong wall outlet.
8. Do not under any circumstances alter the electric plug.
9. Do not use an adapter plug or extension cord with this appliance.
10. To prevent accidental injury, the cord should be secured behind the appliance and not left exposed or dangling.
11. Do not pull out the cable to unplug.
12. Do not turn this appliance on/off by connecting/disconnecting it from the source of electricity.
13. A full water bottle must be connected to the appliance prior to being turned on. (See Page 5).
14. Pour water from the hot water faucet before plugging and switching the appliance on to heat. If the dispenser is turned on with an empty tank, it can be damaged.
15. To reduce the possibility of malfunction, let the water cooler stand upright for approximately 24 hours before connecting the appliance to the power source.
16. This appliance best operates in an environmental temperature between 18°C - 38°C (64°F - 100°F°).
17. Only use compatible sized water bottles (3 or 5 gallons).
18. Keep the ventilation openings at the back of the appliance uncovered and unobstructed.
19. Keep gasoline or any other flammable vapors and liquids away from the water cooler.
20. Do not store explosive substances such as aerosol cans with a flammable propellant in this appliance.
21. Do not place other appliances inside this equipment unless those are recommended by the manufacturer.
22. If you want to move the water cooler, do not tilt more than 45° to avoid damage to the compressor.
23. This water cooler dispenses hot water at a temperature range of 88°C-95°C (190°F-203°F) so use caution when handling the hot water tap.
24. Supervision of children when using is advised.
25. Do not operate the machine for any other purpose other than its intended use.

PRODUCT VIEW

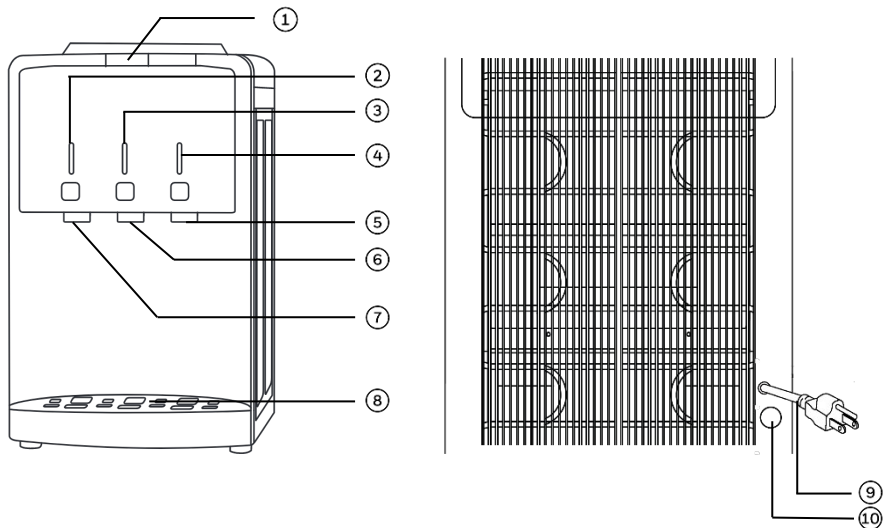

No.	Name	No.	Name
1	Buttons	6	Room Temp Tap
2	Heating Indicator	7	Hot Water Tap
3	Room Temp Indicator	8	Drip Tray
4	Cooling Indicator	9	Power Cord
5	Cold Water Tap	10	Drain Plug

PRODUCT OPERATION

BEFORE PLUGGING IN THE UNIT TO A POWER SOURCE:

1. Let the appliance stand upright for about 2 hours. This will reduce the chance of malfunction in the cooling system from possible mishandling during delivery.

WARNING: The drain cap on the back of the unit may become loose or damaged during shipping. Fasten the drain cap tightly before you start to operate the unit. If the drain cap is loose, the unit may leak and cause floor damage.

2. The units water lines must be flushed with fresh water before use. Follow the steps listed below.
 - i. Fill the reservoir with tap water until full. Wait 5 minutes for the water to settle completely.
 - ii. Push the hot water button until water begins to come out.
 - iii. Plug the water dispenser into a grounded power outlet.
 - iv. Wait for the hot water to come to temperature. About 10 minutes.
 - v. Wait for the cold water to come to temperature. About 40 minutes.
 - vi. Unplug the unit. Drain water from spouts until water cooler is empty. *(Note: make sure to use a large container such as a bucket)*
 - vii. Unscrew drainage cap until all water drains completely.

PRODUCT OPERATION

1. Place the water dispenser on a level surface. Plug the water dispenser into a grounded power outlet.
2. First, the unit will pump the water from the water bottle into the cooling and heating tanks, this takes about 15 minutes. During this time, the unit's compressor will run continuously, this is normal.
3. First, turn the hot water switch on the back of the unit into the ON position. Next, turn the cold water switch into the ON position. **DO NOT TURN ON BOTH SWITCHES AT THE SAME TIME.** Once this is completed both cooling and heating indicator lights should light up.
4. After both switches are turned on, it is recommended that you wait 1 hour before usage. After 1 hour, the water dispenser will be ready to dispense hot, cold, and room temperature water.
5. For ideal usage, it is recommended that 2 Liters of water runs through the water dispenser before use. This is recommended as the unit has been sitting idle during manufacturing.
6. It is recommended that if the hot water option is not used, the hot water switch (red) be turned OFF. This will help conserve energy.

NOTE: The appliance is designed to provide hot or cold water whenever you need it. It will automatically turn on and off when hot and cold water reaches the desired temperatures.

PRODUCT OPERATION

When operating the water dispenser for the first time, you will need at least 15-30 minutes for the hot water to reach the desired temperature and 1 hour for the cold water to reach the desired temperature.

The water dispenser has 3 indicator lights on the front panel:

- When the right GREEN indicator light is on, the unit is in the process of cooling water inside the cooling tank.
- When the left RED indicator light is on, the water dispenser is heating water inside the heated water tank.
- When the middle YELLOW power indicator on the front panel is on, the unit has power and is ready to dispense water.

Using the water dispenser:

- To dispense hot water, slide the hot water safety toggle left and then push the hot water button down.
- To dispense cold water, push the cold water button down.
- To dispense room temperature water, push the room temperature button down.

MACHINE MAINTENANCE

WARNING: Before cleaning, turn the power switch off and disconnect the power cord from the wall.

1. Before the first use and after a long period of not using the appliance, the water tank should be cleaned. It is recommended to wash and disinfect the system every 3-6 months.
2. To begin cleaning, all water must be drained from the unit (**toggle the heating switch to OFF while draining the system**).

WARNING: Because the hot water can reach temperatures around 194°F it can cause severe burns if not handled carefully. Please be cautious while operating and cleaning the unit. It is recommended, for user safety, to let the water cool for at least 1 hour.

3. If the appliance is not going to be used for a long period of time, unplug it and drain all water in its interior.
4. To avoid electric shock, do not clean the outside of the appliance with water. Clean it with a soft cloth.
5. If the power cable suffers any damage, contact the manufacturer, service representative or qualified personnel. Do not attempt to repair the cable yourself.
6. If you are not using the appliance for a long period of time or during the night, you can turn it off to save energy.

MACHINE MAINTENANCE

To sanitize the water tanks:

1. All water must be drained from the unit (flip the heating switch to OFF while draining the system).
2. Unscrew and uncap the drain plug. Have something ready to catch the water from the unit.
3. Remove the water bottle funnel from the top of the machine.
4. Pour the descaling solution into the tank. Make sure the water comes out of the cold water spout by pressing the button.
5. Pour in more solution and turn the heating switch on. Allow the water to heat for **15 minutes**.
6. After the 15 minutes has elapsed, turn the heating switch off. Allow the water to cool for **20 minutes**.
7. Drain the cleaning solution from the unit. Then flush the unit with clean water, repeating steps 4-6. Again, drain the water from the unit. Attach the water bottle funnel and mount a fresh water bottle to the unit. The cleaning process is complete and the unit is ready to use again.

TROUBLESHOOTING

In case of problems, turn off the water dispenser and disconnect from the source of electricity.

Symptom	Solutions
Unit is not dispensing water	<ul style="list-style-type: none">• Check to see if the unit is unplugged.• Check to see if the main power supply is on.• Tighten the water bottle cap and make sure that it is attached properly to the connector on the water dispenser.
Unit does not dispense cold or hot water	<ul style="list-style-type: none">• Overconsumption of cold or hot water can cause this problem, so wait a moment for the water to cool or heat.• Space the unit from the wall by more than 15 cm (5.9") so that ventilation around the unit is sufficient.• The temperature of the water bottle may be too high, so place the water bottle in a cool location out of direct sunlight.
Unit is noisy during operation	<ul style="list-style-type: none">• Place the unit on a flat, level surface.• Make sure that the unit is not touching any other objects.
Leaking	<ul style="list-style-type: none">• Tighten the top threaded portion of the faucet.• Make sure the hose connector is properly connected.• Tighten the drain cap. If the sealing silicon material inside the drain cap is torn or damaged, then contact Royal Sovereign to be replaced.• Check the water container, water pipe and faucet for damages. If broken a replacement must be made.
The water being dispensed has a strange taste	<ul style="list-style-type: none">• This is not uncommon with new water coolers. Do not worry, this is not dangerous to your health.• Clean the unit using a descaling product (preferably a citric acid solution). See page 9 for cleaning instructions.
Power indicator is not lit	<ul style="list-style-type: none">• Make sure that the power switch is ON and the plug is connected to the outlet correctly.
Not heating or cooling	<ul style="list-style-type: none">• Check the electrical connections and make sure they are not loose.• The heating and cooling switches may need to be replaced.• The heating tank may need to be replaced, because it may be burnt out.

NOTE: For all replacements and repairs that need to be made, contact Royal Sovereign Customer Service at 1-800-397-1025

SPECIFICATIONS

MODEL	RWD-300B
Voltage / Frequency	115V – 60 Hz
Heating Power / Cooling Power	500W / 80W
Coldest Temp / Hottest Temp	43° F / 203° F // 6° C / 95°C
Bottle Size	3 / 5 Gallon
Temperatures	Hot / Room / Cold
Cooling Type	Compressor
Dimensions	13.2" W x 12.6"D x 19.7"H
Weight	22lbs. / 9.97 kg.

ONE YEAR LIMITED WARRANTY

Royal Sovereign International, Inc. warrants this product to be free from defects in material and workmanship for a period of one (1) year. This warranty is extended to the original purchaser only.

This warranty only covers products that are properly installed, properly maintained, and properly operated in accordance with the instructions provided. This limited warranty does not cover any failures or operating difficulties due to normal wear and tear, accident, abuse, misuse, alteration, misapplication, improper installation, or improper maintenance and service by you or any third party.

Returned product will not be accepted without a Return Authorization number. To request a Return Authorization number, please visit us at www.royalsovereign.com. All transportation costs for the return of damaged product or parts will be the responsibility of the purchaser. Return defective product, in original packaging, to the address below.

Royal Sovereign International, Inc. requires reasonable proof of your date of purchase from an authorized retailer or distributor. Therefore, you should keep your receipt, invoice, or canceled check from the original purchase. The limited warranty shall be limited to the repair or replacement of parts which prove defective under normal use and service within the warranty period.

Royal Sovereign International, Inc. (and its affiliated companies) SHALL HAVE NO LIABILITY WHATSOEVER TO PURCHASER OR ANY THIRD PARTY FOR ANY SPECIAL, INDIRECT, PUNITIVE, INCIDENTAL, OR CONSEQUENTIAL DAMAGES. Some states do not allow the exclusion or limitation of incidental or consequential damages so the above exclusion and limitations may not apply to you.

For product support and warranty questions, please visit us at www.royalsovereign.com

ROYAL SOVEREIGN INTERNATIONAL, INC.

2 Volvo Dr., Rockleigh, NJ 07647 USA

TEL: 1-800-397-1025

Email: info@royalsovereign.com