

Steam Trap Selection Guide

Hoffman Specialty

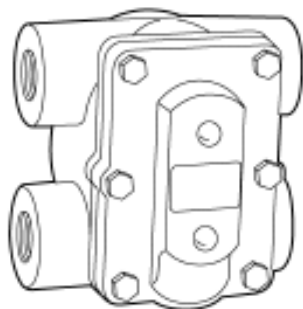

Series H Float and Thermostatic Steam Traps

Materials of Construction	
Part	Specifications
Body and Cover	Cast Iron 30,000 psi tensile
Valve Pin and Seat	Stainless Steel (Hardened)
Float	Stainless Steel
Lever Assembly	Stainless Steel
Thermostatic Air Vent	Stainless Steel Cage and Thermal Element
Cover Bolts	Grade 5

Ratings			
NPT Size Inches	Maximum Allowable Pressure psi (bar)	Maximum Operating Pressure psi (bar)	Maximum Temperature °F (°C)
3/4, 1 & 1-1/4	250 (17.3)	175 (12.1)	406 (208)
1-1/2 & 2	175 (12.1)	175 (12.1)	377 (192)

Meets Mil Specification A-A-60001 Type VI, Class 1 - 5.

SCHEDULE

PART NUMBER	MODEL NUMBER	SIZE NPT INCHES	INLET PRESS. psi (bar)	DIFF. PRESS. psi (bar)	FLOW RATE lb/hr (kg/hr)	TAGGING INFORMATION	QUANTITY
404200	FT015H-3	3/4					
404210	FT015H-4	1					
404220	FT015H-5	1-1/4					
401626	FT015H-6	1-1/2					
401629	FT015H-8	2					
404202	FT030H-3	3/4					
404212	FT030H-4	1					
404222	FT030H-5	1-1/4					
401638	FT030H-6	1-1/2					
404204	FT075H-3	3/4					
404214	FT075H-4	1					
404206	FT125H-3	3/4					
404216	FT125H-4	1					
404208	FT175H-3	3/4					
404218	FT175H-4	1					

Building Controls Group

2300 Myrtle Ave. St. Paul, MN 55114 (651)289-1310

On Line at buildingcontrolsgroup.com

Steam Trap Selection Guide

Series H Float and Thermostatic Steam Traps

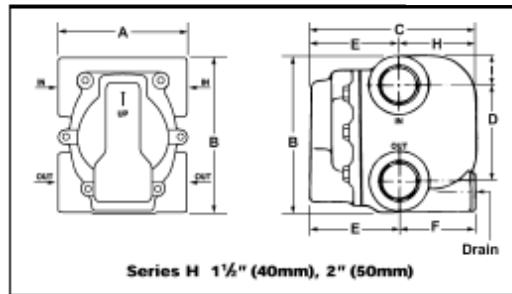
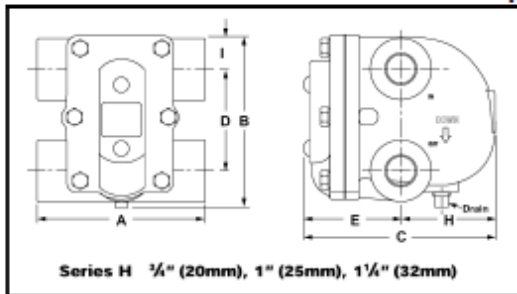

Dimensions, in. (mm)

NPT Size in.	A	B	C	D	E	F	H	I	Weight lbs. (kg)
3/4	5-1/2 (140)	5-19/32 (142)	6-1/2 (165)	3-5/16 (84)	3-13/32 (86)	-	3-1/16 (78)	1-5/64 (27)	11.7 (5.3)
1	5-1/2 (140)	5-19/32 (142)	6-1/2 (165)	3-5/16 (84)	3-13/32 (86)	-	3-1/16 (78)	1-5/64 (27)	11.7 (5.3)
1-1/4	5-1/2 (140)	5-19/32 (142)	6-1/2 (165)	3 (76)	3-13/32 (86)	-	3-1/16 (78)	1-5/64 (27)	11.7 (5.3)
1-1/2	6-3/8 (162)	7-11/16 (195)	8-7/32 (209)	5-1/4 (133)	4-13/32 (112)	3-13/16 (97)	3-13/16 (97)	1-11/32 (34)	22 (10)
2	6 (152)	11 (279)	9-5/32 (233)	7-15/32 (190)	4-17/32 (115)	4-7/32 (107)	4-5/8 (117)	1-5/8 (41)	38 (17)

Capacities (Gross Ratings)

Model	NPT Size in.	Orifice Size in. (mm)	Pressure Differential in Pounds Per Square Inch (bar)																	
			1/4 (0.017)	1/2 (0.035)	1 (0.07)	2 (0.14)	5 (0.35)	10 (0.69)	15 (1.0)	20 (1.4)	25 (1.69)	30 (2.1)	40 (2.8)	50 (3.5)	60 (4.2)	75 (5.2)	100 (6.9)	125 (8.6)	150 (10.4)	175 (12.1)
			Capacity in Pounds of Condensate Per Hour (kg/hr)																	
FT015H-3	3/4	.253 (6.4)	390 (177)	500 (227)	680 (308)	910 (413)	1100 (500)	1450 (658)	1600 (725)	-	-	-	-	-	-	-	-	-	-	-
FT015H-4	1	.253 (6.4)	390 (177)	500 (227)	680 (308)	910 (413)	1100 (500)	1450 (658)	1600 (725)	-	-	-	-	-	-	-	-	-	-	-
FT015H-5	1-1/4	.312 (8)	600 (272)	770 (350)	980 (444)	1240 (562)	1640 (744)	2000 (907)	2340 (1062)	-	-	-	-	-	-	-	-	-	-	-
FT015H-6	1-1/2	.500 (13)	1280 (581)	1700 (771)	2050 (930)	2550 (1157)	3500 (1588)	4400 (1996)	5300 (2404)	-	-	-	-	-	-	-	-	-	-	-
FT015H-8	2	.687 (17)	2500 (1134)	3150 (1429)	4000 (1814)	5000 (2268)	6800 (3084)	8300 (3765)	9800 (4405)	-	-	-	-	-	-	-	-	-	-	-
FT030H-3	3/4	.235 (6)	380 (172)	470 (214)	630 (285)	870 (395)	1050 (475)	1380 (625)	1530 (695)	1700 (770)	1820 (825)	1900 (860)	-	-	-	-	-	-	-	-
FT030H-4	1	.235 (6)	380 (172)	470 (214)	630 (285)	870 (395)	1050 (475)	1380 (625)	1530 (695)	1700 (770)	1820 (825)	1900 (860)	-	-	-	-	-	-	-	-
FT030H-5	1-1/4	.253 (6.4)	420 (190)	550 (250)	740 (335)	1000 (450)	1200 (545)	1550 (700)	1760 (800)	1850 (840)	2000 (907)	2200 (1000)	-	-	-	-	-	-	-	-
FT030H-6	1-1/2	.438 (11)	580 (263)	800 (362)	1200 (544)	1680 (762)	2600 (1179)	3500 (1587)	4500 (2041)	5200 (2358)	5700 (2585)	6100 (2766)	-	-	-	-	-	-	-	-
FT075H-3	3/4	.166 (4.2)	160 (72)	210 (95)	280 (125)	360 (165)	520 (235)	700 (320)	800 (360)	870 (395)	930 (420)	970 (440)	1120 (510)	1230 (560)	1300 (590)	1450 (658)	-	-	-	-
FT075H-4	1	.166 (4.2)	160 (72)	210 (95)	280 (125)	360 (165)	520 (235)	700 (320)	800 (360)	870 (395)	930 (420)	970 (440)	1120 (510)	1230 (560)	1300 (590)	1450 (658)	-	-	-	-
FT125H-3	3/4	.125 (3.2)	100 (45)	130 (60)	170 (77)	230 (104)	330 (150)	410 (186)	500 (225)	560 (255)	620 (280)	660 (300)	750 (340)	830 (375)	890 (400)	970 (440)	1100 (500)	1190 (540)	-	-
FT125H-4	1	.125 (3.2)	100 (45)	130 (60)	170 (77)	230 (104)	330 (150)	410 (186)	500 (225)	560 (255)	620 (280)	660 (300)	750 (340)	830 (375)	890 (400)	970 (440)	1100 (500)	1190 (540)	-	-
FT175H-3	3/4	.106 (2.7)	70 (32)	80 (36)	110 (50)	140 (63)	220 (100)	280 (127)	340 (155)	380 (172)	400 (180)	420 (190)	460 (210)	480 (220)	520 (235)	580 (263)	690 (315)	850 (385)	960 (435)	1000 (454)
FT175H-4	1	.106 (2.7)	70 (32)	80 (36)	110 (50)	140 (63)	220 (100)	280 (127)	340 (155)	380 (172)	400 (180)	420 (190)	460 (210)	480 (220)	520 (235)	580 (263)	690 (315)	850 (385)	960 (435)	1000 (454)

Building Controls Group

2300 Myrtle Ave. St. Paul, MN 55114 (651)289-1310

On Line at buildingcontrolsgroup.com



Steam Trap Selection Guide

Instructions for finding F&T steam trap size.

Things to ask customer:

1) Pounds per hour of Steam. _____

2) System Pressure (this usually the relief valve pressure). _____

Multiply pounds per hour of steam by 1.5. (_____ x 1.5 = _____)

Under the “Pressure differential in pounds per square inch” find the “1/2” column in chart on page 2 and find the calculated pounds per hour from the previous step.

Using the column on the left of the chart find the relief pressure for the system. This will be the numbers to the right of the “FT” part of the model number.

The model number that contains the system pressure and is to the left of the calculated pounds per hour of steam is the model number of your steam trap.

The following pages are from Xylem and is the selection guide that they publish for all of their Steam Traps.

Building Controls Group

2300 Myrtle Ave. St. Paul, MN 55114 (651)289-1310

On Line at buildingcontrolsgroup.com

Steam Trap Selection Guide

Steam Traps

Selecting and Sizing Steam Traps

Selecting the proper steam trap is important in effective operation of steam systems. Steam traps are automatic valves that open to pass condensate and close to prevent the flow of steam. The functions of a steam trap in a steam system are to:

- Vent air from the system so steam can enter
- Hold steam in the system until the steam latent heat is removed
- Drain condensate from the system as it is formed after the latent heat is removed.

Removing condensate from piping helps prevent erosion and water hammer. Removing condensate from heat exchangers is required to make room for new steam for the heating process.

There are many types of steam traps. The [Steam Trap Selection Guide Chart](#) points out system conditions that may be encountered and suggests the trap type(s) that may best handle the requirement. Several types of traps may be used for a specific application.

Factors to consider in selecting the type of trap include:

- Constant or modulating condensate load
- Constant or fluctuating pressure
- Speed of air venting required
- Trap location

TRAP SIZING

1. Determine the maximum condensate load (capacity) requirement for the trap by one of the following:
 - Referring to the manufacturers' specifications for the system equipment.
 - Approximating condensate loads using the "General Usage Formulas".
 - Using the "CalcLoad" Load Calculator available through "Steam Specialty Component Selector" on the Hoffman Specialty website or ESP-Plus.
2. Determine the available steam inlet pressure at the trap (This pressure could be different than supply pressure at boiler.)
3. Determine the outlet pressure (backpressure) at the trap discharge. (Pressure against the outlet can be due to static pressure in return line or due to lifting to an overhead return).
4. Determine the pressure differential across the trap. (inlet pressure - outlet pressure = differential pressure).

5. Determine a Safety Factor. The Safety factor will depend on accuracy in determining condensate load, inlet and outlet pressures. Recommendations:

- Float & Thermostatic Trap 1.5 to 2.5
- Bucket Trap 2 to 4
- Thermostatic Trap 2 to 4
- Thermodisc Trap 1 to 1.2

6. Multiply normal maximum condensate load (as determined above) by Safety Factor.

7. Use the Capacity Tables for the selected type of trap to determine the trap model number.

8. Use Ordering Information Charts to determine the part number.

Guidelines:

- The trap seat rating must always be higher than the maximum inlet pressure at the trap.
- When a modulating control valve controls the inlet to equipment, select a trap size with a pressure rating greater than the maximum inlet pressure at the trap.
- Trap capacity should be checked at the minimum differential pressure to assure complete condensate removal under all possible conditions.

Inverted Bucket Trap Operating Pressure Selection:

- Bucket traps are offered with various orifice sizes that determine the maximum operating pressure rating.
- A trap with a lower seat pressure rating has a larger sized orifice than a trap with a higher seat pressure rating. The larger orifice provides a larger condensate rating. When the actual operating pressure is higher than the seat rating, the pressure differential across the seat will prevent the trap from opening. Thus, an inverted bucket trap must be selected for the maximum differential pressure that will be encountered by the trap.
- Trap Capacity Tables show trap capacities at lower differential pressures than the trap rating. This allows selection of a trap at various operating points. A trap with a higher seat pressure rating may be used at lower pressure differentials. However, the capacity rating at that pressure differential will be less than the same size trap with a lower seat pressure rating.

Building Controls Group

2300 Myrtle Ave. St. Paul, MN 55114 (651)289-1310

On Line at buildingcontrolsgroup.com

Steam Trap Selection Guide

Steam Traps (continued)

Selecting and Sizing Steam Traps (continued)

Lifting Condensate to Overhead Return

Condensate must be lifted in applications where the trap is installed below the return line.

Guidelines:

- Steam pressure at the trap inlet lifts the condensate. Differential steam pressure across the steam trap of 1 psi (0.07 bar) will lift condensate 2 ft. (0.6 m).

- Do not return condensate to an overhead return if modulating control valves are installed. Modulating control valves may cause the inlet pressure to modulate to 0 psi (0 bar). This condition will result in no differential pressure to push the condensate into the overhead return. When this happens, condensate will back up into the steam chamber and result in water hammer. Use a Hoffman condensate unit to collect condensate

Steam Trap Criteria Comparison

CRITERIA	F&T	Inverted Bucket	Thermostatic	Thermodisc
Response to Load Changes	Fast	Moderate	Moderate	Slow
Air Venting	Medium/High	Low	High	Low
Thermal Efficiency	Medium/High	Medium	High	Medium
Primary Applications	Drip Legs Process Equip.	Drip Legs Process Equip.	Drip Legs Process Equip. Tracing	Drip Legs Tracing
Affected by Ambient Temperatures	No (Susceptible to freezing)		No	Yes (unless insulated)
Relative Cost	Medium/High	Medium/Low	Low	Low
Capacity	High	High	Medium	Low
Pressure Range	to 250 psig (17.3 bar)	to 250 psig (17.3 bar)	to 125 psig (8.6 bar)	to 600 psig (41.4 bar)
Size vs. capacity	Large	Large	Small	Medium
Ease of Maintenance	Moderate	Moderate	Very Easy	Very Easy
Orientation limits	Yes	Yes	No	No

Building Controls Group

2300 Myrtle Ave. St. Paul, MN 55114 (651)289-1310

On Line at buildingcontrolsgroup.com

Steam Trap Selection Guide

Steam Trap Selection Guide Chart

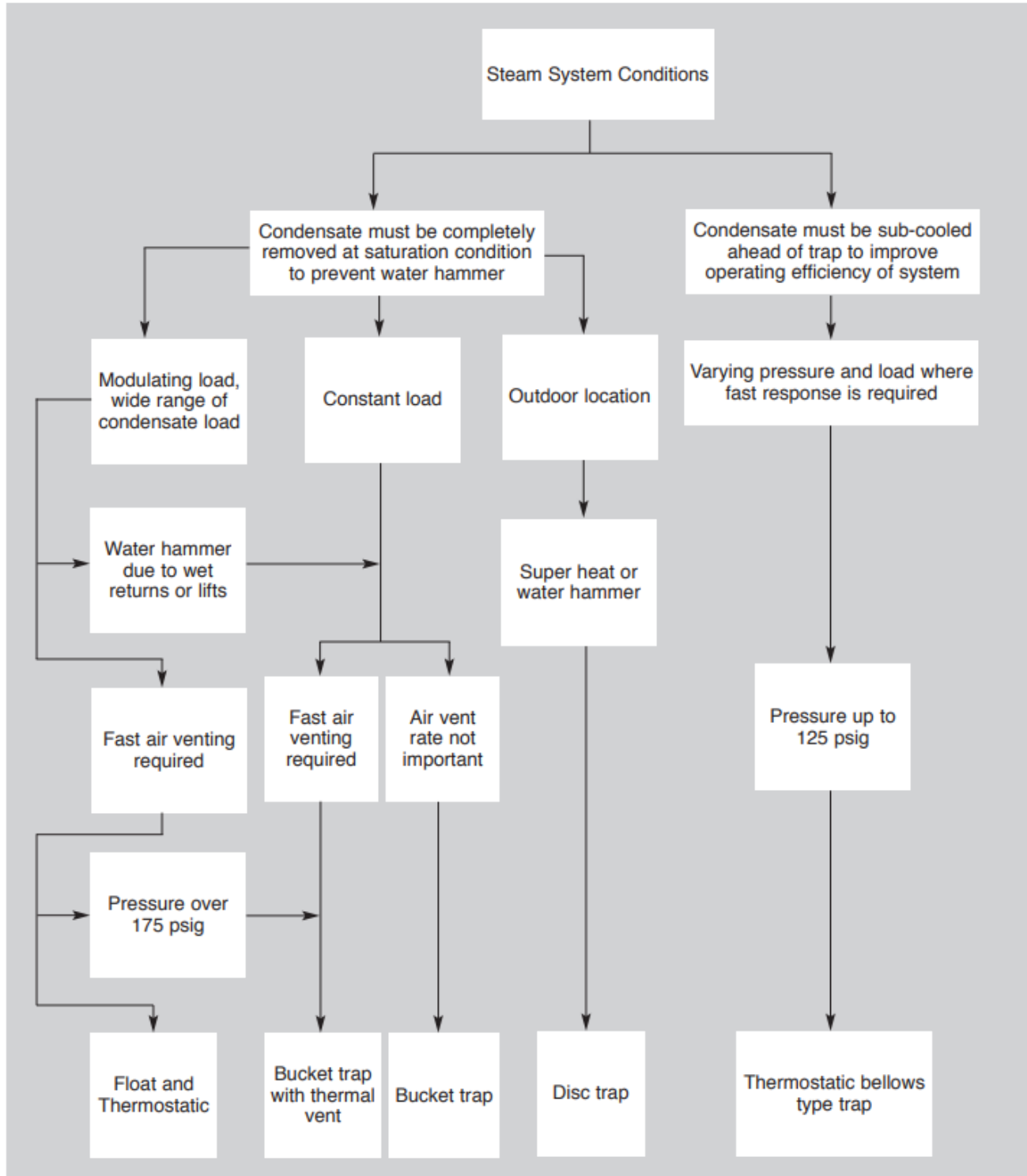

Steam Trap Selection Guide

Steam Traps (continued)

Steam Trap Application Guide

This application guide is designed to help in the selection of the type of steam trap for the type of application. The choices are based upon common usage. However, the

specific choice of trap type should be based upon variations in the individual system and personal preference. This chart should serve only as a guide.

APPLICATION	F&T	Inverted Bucket	Thermostatic	Thermodisc
Mains & Tracing Lines				
Steam Mains				
to 30 psig (2.1 bar)	2	3	1	
to 250 psig (17.3 bar)	1	2		3
to 600 psig (41.4 bar)				1
Steam Tracing Lines				
Critical	2	2	2	1
Non-Critical	2	2	1	2
HVAC				
Heat Exchangers				
to 20 psig (1.4 bar)	1	2	2	
to 125 psig (8.6 bar)	1	2	2	
to 250 psig (17.3 bar)	1	2		
Radiators			1	
Unit Heaters	1	2	1	
Air Heating Coils				
to 15 psig (1.0 bar)	1	3	2	
to 60 psig (4.1 bar)	1	2	2	
Absorption chiller	1	2	2	
PROCESS EQUIPMENT				
Process Vats	1			2
Tank Heating				
Storage Tanks	2		1	
Line Heaters	1		2	
Reboiler	1	2		
Rotating Cylinders	1	2		
Evaporators	1	2		
Sterilizer	1		2	
Pressing	1	2	1	
Cooker/Reactor				
to 15 psig (1.0 bar)	1	3	2	
to 60 psig (4.1 bar)	1	2	1	
to 150 psig (10.1 bar)	1	2		

KEY: 1 = First Choice
 2 = Second Choice
 3 = Third Choice
 Blank = Not Recommended

Building Controls Group

2300 Myrtle Ave. St. Paul, MN 55114 (651)289-1310

On Line at buildingcontrolsgroup.com