

Honeywell Controllinks interface to LFL1.355

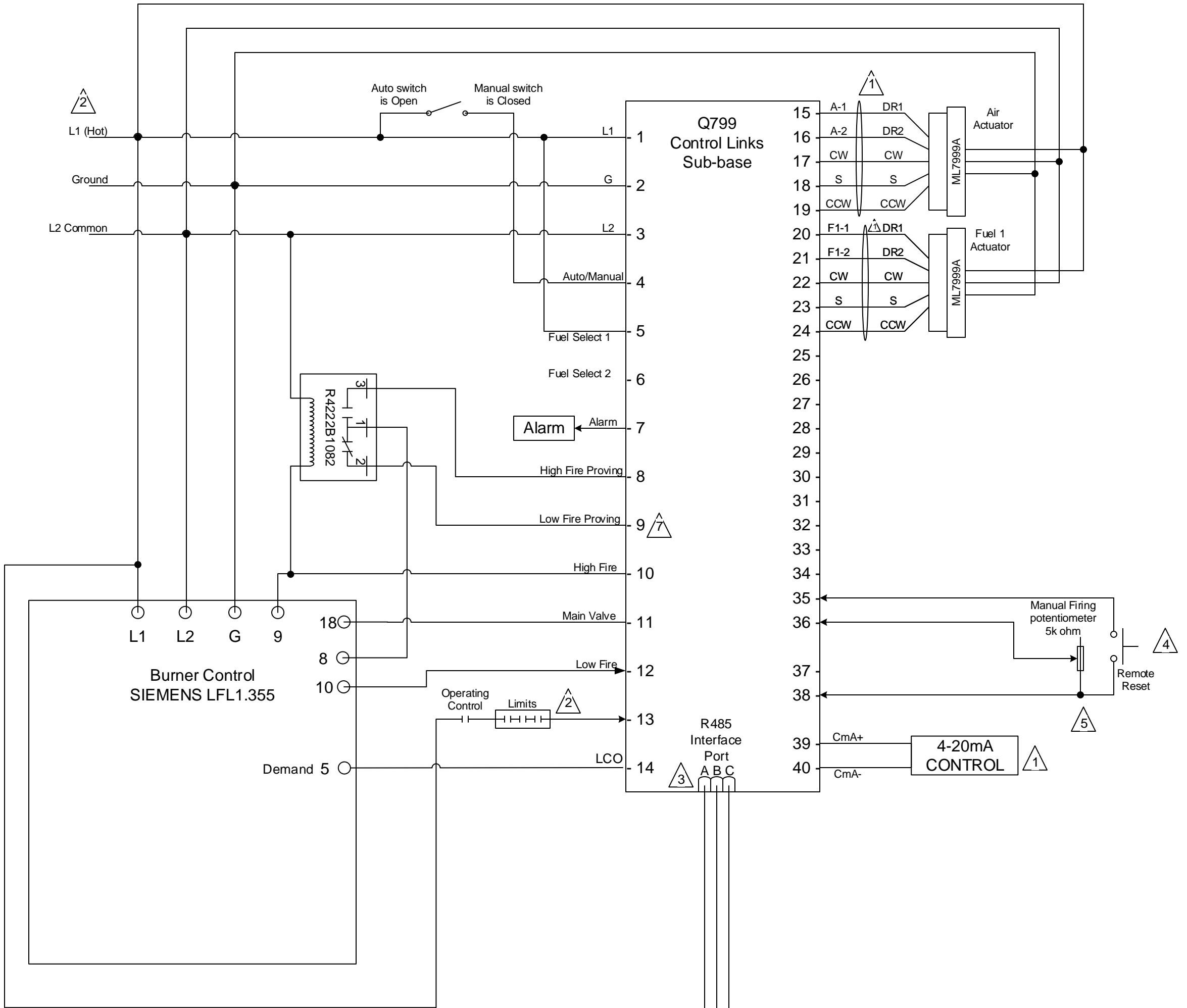

- ① Ground shield to subbase earth ground screw on low voltage side of subbase.
- ② Fuse line voltage control system with type CS15 fuse or fuse limit input type SC5 fuse.
- ③ RS-485 DDL connector is on R799B controller.
- ④ Normally open momentary switch (Connection between terminals 35 & 38).
- ⑤ Manual firing rate potentiometer (Connection between terminals 36 & 38).

