

DC Fast Service Manual

1. Security Compliance

- Disconnect the power supply to the MaxiCharger during the entire installation procedure.
- The load capacity of the grid must meet the requirements of the MaxiCharger.
- Connect the MaxiCharger to a grounded, metal, permanent wiring system. Otherwise, use the equipment-grounding conductor with the circuit conductors and connect it to the equipment grounding terminal or lead on the product.
- Unqualified personnel must keep a safe distance during the entire installation procedure.
- The connections to the MaxiCharger must comply with all applicable local rules.
- Only use electrical wires of sufficient gauge and insulation to handle the rated current and voltage demand.
- Protect the wiring inside the MaxiCharger from damage and do not obstruct the wiring when you perform maintenance on the cabinet.
- Keep the cabinet away from all water source.
- Protect the MaxiCharger with safety devices and measures as specified by local rules.
- Wear proper personal protective equipment such as protective clothing, safety gloves, safety shoes, and safety glasses when necessary.

Refer to “MaxiCharger DC installation and Operation Manual” for more details.

2. Terms and Abbreviations

No.	Abbreviations	Detailed Description
1	AC	Alternative Current
2	ALM	Adaptive Load Management
3	BMS	Battery Management System
4	CAN	Controller Area Network
5	CCS	Combined Charging System
6	CCU	Communication Control Unit
7	CHAdEMO	trade name of a fast-charging system for battery electric vehicles
8	CPU	Central Processing Unit
9	DC	Direct Current
10	DLB	Dynamic Load Balancing
11	DNS	Domain Name System
12	DPA	Dynamic Power Allocation
13	DTC	Diagnostic Trouble Code
14	ECU	Electronic Control Unit
15	ELCB	Earth Leakage Circuit Breaker

16	FPGA	Field Programmable Gate Array
17	FW	Firmware
18	GFCI	Ground Fault Circuit Interrupter
19	IMU	Isolation Measurement Unit
20	MAC	Media Access control
21	MCB	Miniature Circuit Breaker
22	MCCB	Molded Case Circuit Breaker
23	MCU	Main Control Unit
24	NFC	Near Field Communication
25	OBD	On-Board Diagnostics
26	OCPI	Open Charge Point Interface
27	OCPP	Open Charge Point Protocol
28	OS	Operating System
29	PCB(A)	Printed Circuit Board (Assembly)
30	PLC	Programmable Logic Controller
31	PME	Protective Multiple Earthing
32	POS	Point of Sale
33	PWM	Pulse-width Modulation
34	RCBO	Electromagnetic type residual current operated circuit -breaker with integral overcurrent protection
35	RCCB	Residual Current Circuit Breaker
36	RCD	Residual Current Device
37	RFID	Radio-Frequency Identification
38	SIM	Subscriber Identity Module
39	SOC	State Of Charge
40	SOH	State Of Health
41	SPD	Surge Protective Device
42	SPI	Serial Peripheral Interface
43	TCU	Transmission Control Unit
44	USB	Universal Serial Bus
45	VCI	Vehicle Communication Interface
46	VtoG	Vehicle to Grid

3. Technical Specification

3.1 Screw Torque Table

Control board (M3 screws, torque value $5.5 \pm 10\%$ kgf.cm) , copper busbar (M4 screws, torque value $12 \pm 10\%$ kgf.cm ;M6 screws, torque value $12 \pm 10\%$ kgf.cm; M8 screws, torque value $70 \pm 10\%$ kgf.cm; M10 screws, torque value $120 \pm 10\%$ kgf.cm), circuit breaker (The specific value is subject to the recommended torque value that comes with the part. If there is no recommended value, please refer to the following Table 1 for General Connection 2.), charger wire, DC contactor (M8 screws. The specific value is subject to the recommended torque value that comes with the

part. If there is no recommended value, please refer to the following Table 1 for General Connection 2.), fan (M4 screws, torque value $12 \pm 10\%$ kgf.cm) and screen (M4 screws, torque value $12 \pm 10\%$ kgf.cm)

Table 1 Torque Wrench Calibration Table (Unit: kgf.cm)

Screw Spec.	General Connection		
	1	2	3
	Steel (direct tapping, counter tapping) and die-cast aluminum	Steel (rivet nut or bolted joint)	Aluminum, copper and plastic
M2	1.5	1.5	0.8
M2.5	3	3	1.6
M3	5	5.5	3
M4	10	12	6
M5	13	20	10
M6	28	30	15
M8	65	70	35

The values in this table are recommended values when the strength rating of the screw (nut) is 4.8 (≥ 6), the yield strength is greater than 200 MPa for the direct tapping base steel plate and greater than 175 MPa for other aluminum materials, and the selected die-cast aluminum is ADC12.

When the materials of the two connecting materials are different, the corresponding value of the one with the lower material strength should be selected.









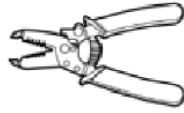

Torque tolerance is $\pm 10\%$.

Adjust the torque to an appropriate level according to the diameter of the screws and nuts when screwing fasteners with an electric screwdriver to avoid damage to the cross groove of the screws. The adjustment basis is shown in Table 2.

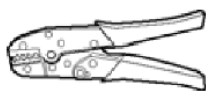
Table 2 Correspondence between Electric Screwdriver Screwing Force and Fastener

Screw	Torque Range (kgf.cm)	Body Weight (Kg)	Body Length (mm)	Flexible Shaft Diameter (mm)
M2	2-5	0.27	196	6.35
M3	5-10	0.42	231	
M4	8-16	0.57	245	
M5	16-28	0.70	257	
M6	35-55	1.05	253	

3.2 List of Maintenance Tools

 Phillips Screwdriver	 Multimeter	 Wire stripper	 Wire Cutter
 Crimping Tool	 Heat Gun	 Heat Shrink Tubing	 Safety Gloves
 Safety Shoes	 Suction Cup		

Electric screwdriver or Phillips screwdriver, torque wrench/socket wrench (5.5 mm (M3 hexagon screw), 7 mm (M4 hexagon screw), 10 mm (M6 hexagon screw), 13 mm (M8 hexagon screw), 16 mm (M10 hexagon screw)), suction cup (quantity: 2; used for replacement of TCU assembly)

4. System Introduction

4.1 Charger Appearance

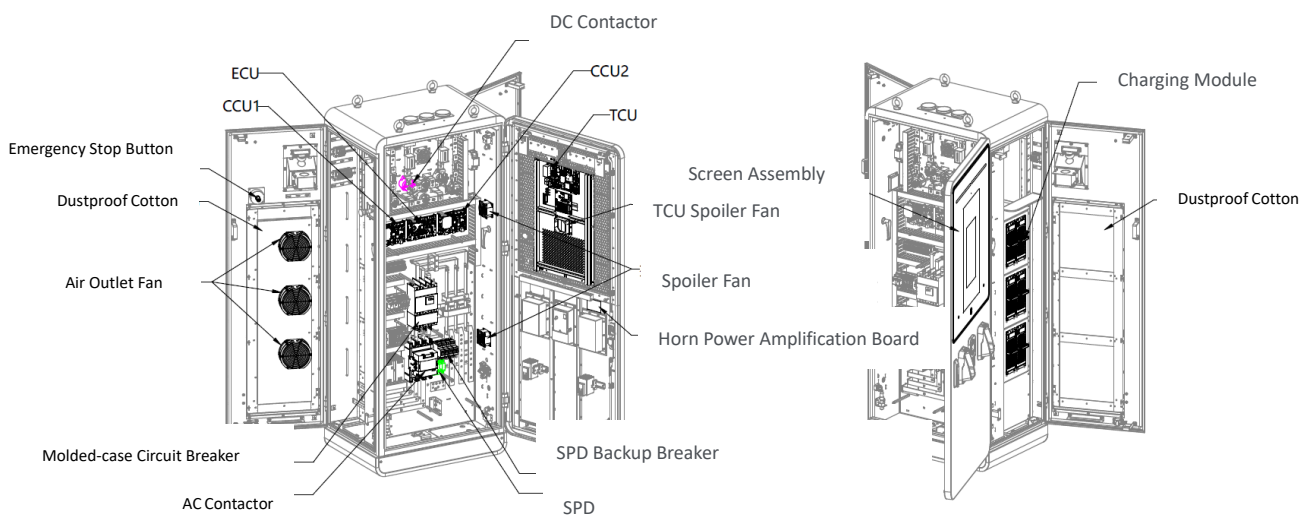

120 kW DC Charger (IEC) Maintenance Component Layout

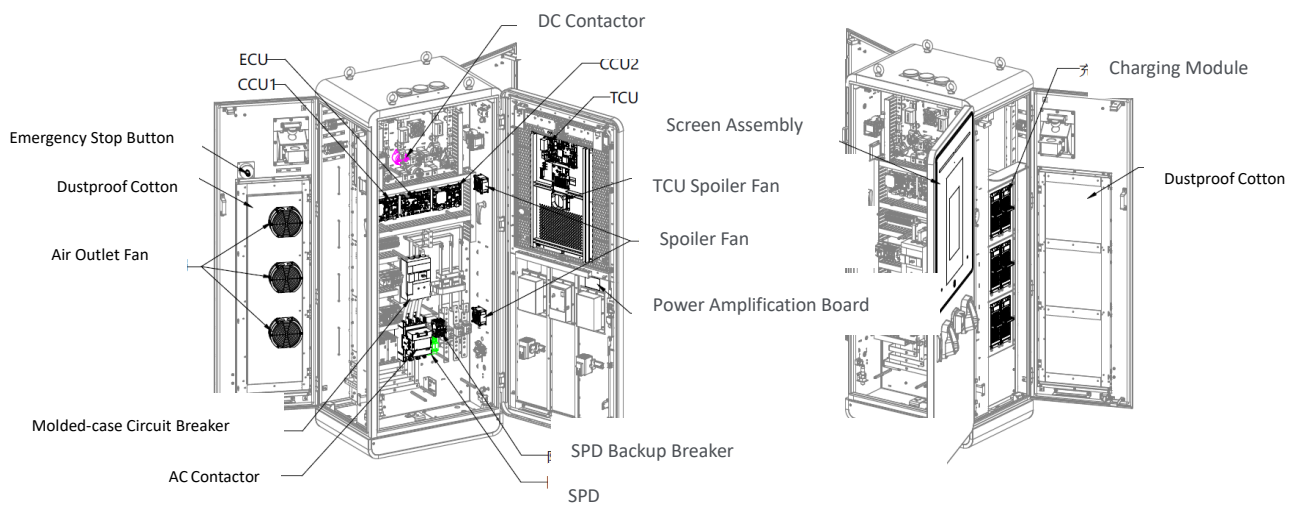

120 kW DC Charger (UL) Maintenance Component Layout

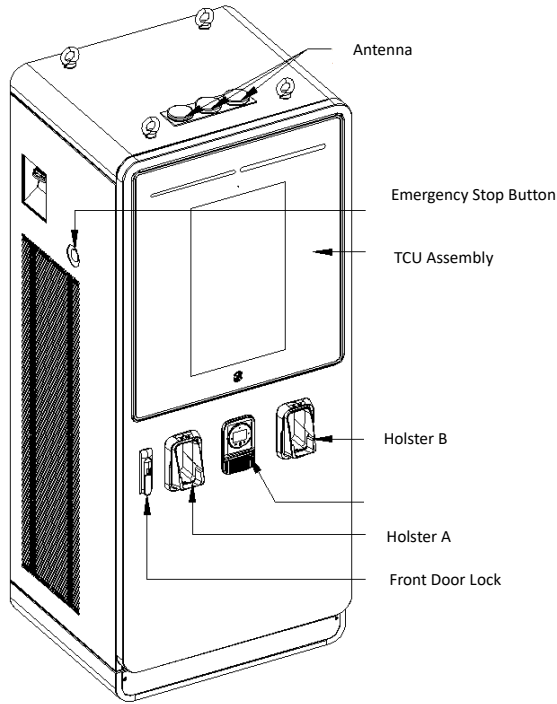

Axonometric View

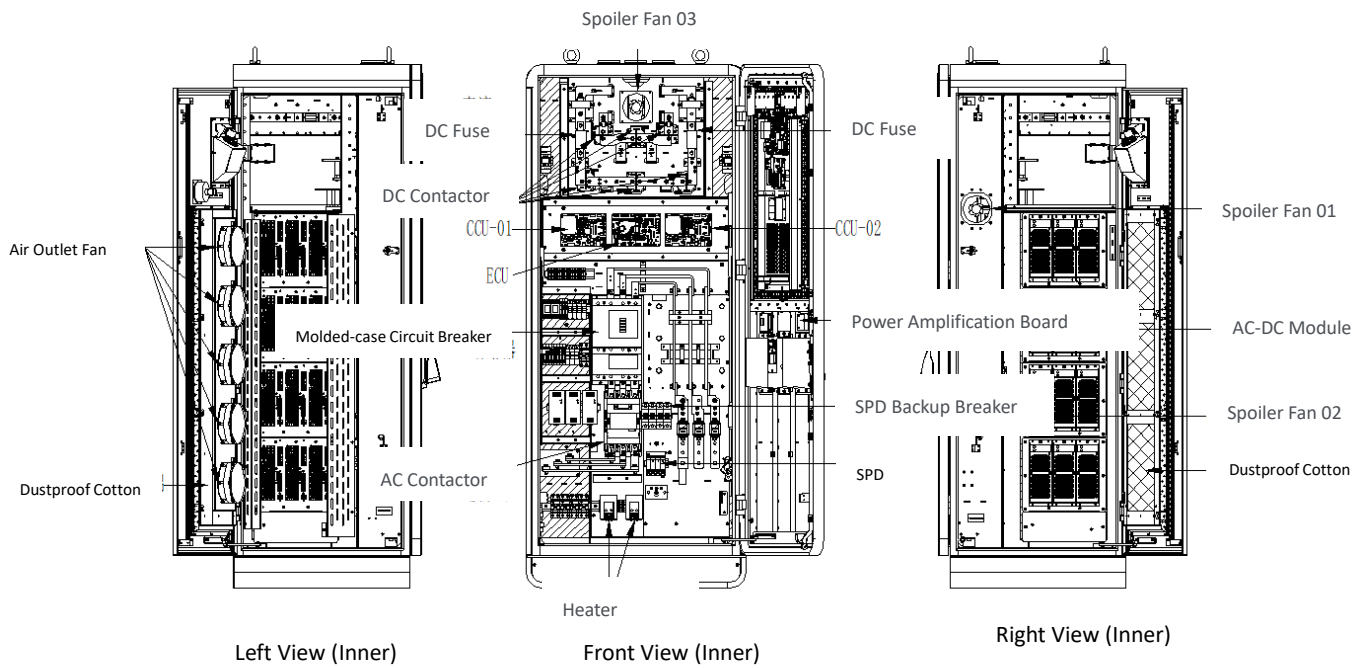

240 kW DC Charger (CE)

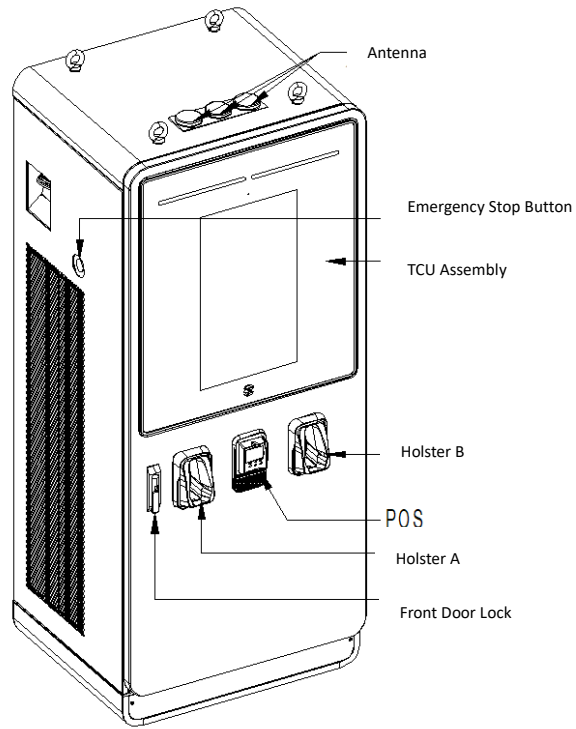

Axonometric View

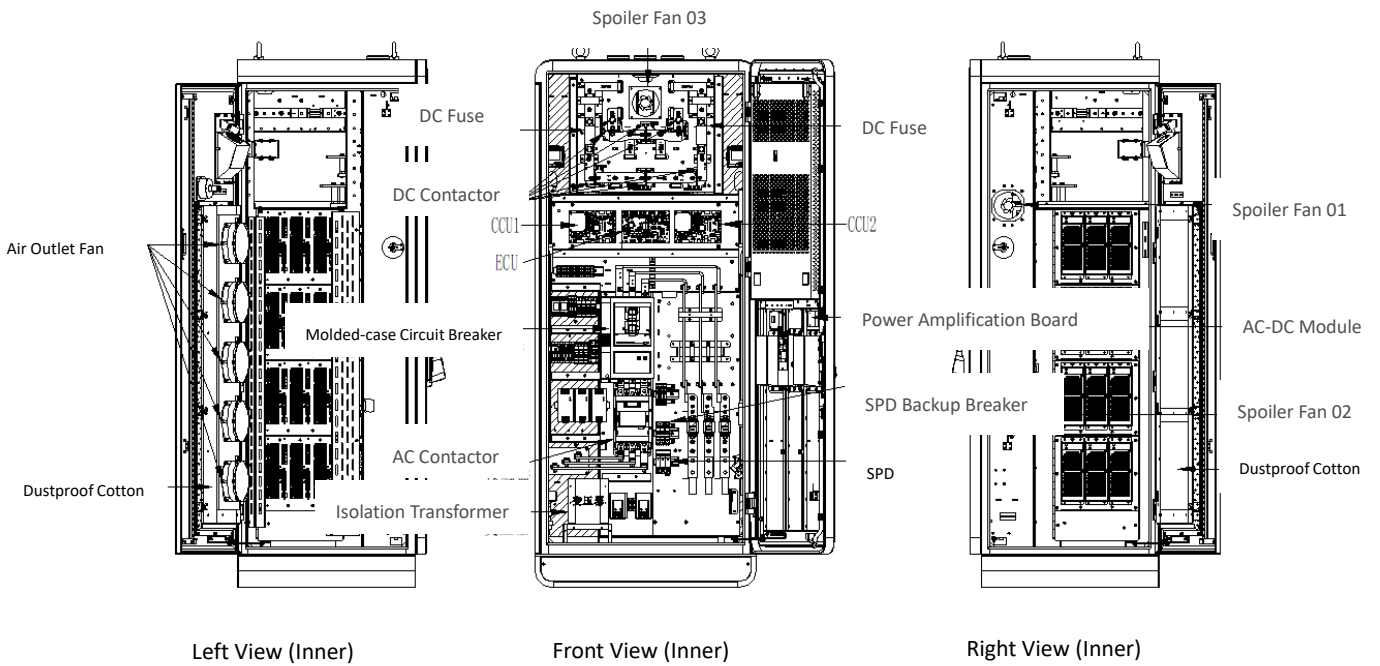

240 kW DC Charger (UL)

5. Maintenance Requirements

5.1 General Maintenance Requirements

Periodic maintenance must be established in order to obtain the best service from the EVSE charger. An annual check of the switchgear devices and all connections should be the minimum requirement. Equipment subject to highly repetitive operation may require more frequent maintenance. A permanent record of all maintenance work should be kept. The record should include a list of periodic checks and tests made, the date they were made, the condition of the equipment, and any repairs or adjustments that were performed. Maintenance employees must follow all recognized safety practices, such as those contained in the National Electric Safety Code and in company or other safety regulations. For specific information regarding the maintenance of devices, such as circuit breakers, RCD, relays, meters, etc, refer to the separate instruction book provided for each device.

5.2 Enclosure Maintenance Requirements

The enclosure station requires no maintenance other than occasional cleaning.
Warning: To reduce the risk of electrical shock or equipment damage, do not allow opening the unit while cleaning it. Enclosure maintenance is performed only externally.
Clean the enclosure using a soft cloth lightly moistened with mild detergent solution.
Never use any type of abrasive pad, scouring powder, or flammable solvents such as alcohol or benzene.

5.3 Power Circuit Maintenance Requirements

Inspection of the power circuit is recommended at least once a month. More frequent inspections are recommended, if several load conditions, dust, moisture, or other unfavorable conditions exist.

- MCB, RCD

If the breaker remains open or closed for a long period of time, it is recommended that arrangements be made to open and close it several times in succession, preferably under load. At all times, it is important not to permit paint, oil or other foreign materials to remain on the insulating surfaces or the breaker as they may cause low resistance between points of different potential and result in eventual electrical breakdown.

Always inspect the devices after a short circuit current has been interrupted.

Normally, the over current protective device on the circuit will prevent any electrical damage except at the actual point of the short circuit.

A thorough inspection of the entire system must be made after any large fault current to insure that there has been no mechanical damage to conductors, insulation, or equipment.

Do not open sealed devices such as breaker trip units. If there is any possibility that sealed units may have been damaged, they should be replaced.

At the time of inspection, the following checks should be made after the device has been de-energized.

- Manually operate the device several times checking for obstructions or excessive friction.
- Electrically operate the device several times (if breaker has electrical control) to ascertain whether the electrical attachments are functioning properly.
- Break-age of parts or extensive burning will indicate need for replacement.
- Check operation of tripping devices, including over current trip devices, making sure all have positive tripping action. (Discernible movement in tripping direction beyond point of tripping).
- Push test-button in the RCD device: positive tripping action (ensure RCD device is powered, therefor the contactor should be closed manually).

- Contactor

Ensure a trouble free operation of the contactor until the next service is required. As in the previous devices, always inspect the device after main breaker tripping. At the same time, observations can be made to judge if the contactor operates well in the application.

Ensure that electrical continuity in all the poles is retained and should be operable in ON/trip/reset sequence manually. If there is any possibility the unit has been damaged, it should be replaced. For additional details on the particular device, refer to the applicable instruction manual provided with the device.

- Impulse Surge Arrester

The surge arresters do not contain wearing parts and therefor, they are maintenance free.

Replacement parts are not needed. Maintenance is based into a visual inspection of the following parts:

- Check that the arrester housing is clean and free from where is installed.
- The monitoring device for leakage current (Fault indicator) is reviewed as it is indicated.

It is recommended to replace the units that caused the mechanical defect of the surge arrester.

5.4 Gaskets Maintenance Requirements

Gaskets require regular maintenance to prevent mold and mildew and to maintain the elasticity of the seal. Visually check the different gaskets or lid for tears or punctures. Leaks are indicated by a streak of frost that forms at the point of gasket failure.

Gasket and retainer groove cleaning can be accomplished with the use of warm soapy water and a soft bristle brush.

CAUTION: Avoid full strength cleaning products on gaskets as this can cause them to become brittle and prevent proper sealing. Never use sharp tools or knives to scrape or clean the gasket. This could tear the gaskets.

5.5 Cable Maintenance Requirements

Inspect and check the cables as follows:

- Inspect all power cable connections for signs of overheating and tighten all connections.
- If severe discoloration or if damage is apparent, remove the damaged cable and replace any device with damaged terminal.
- Check the neutral bus and earth bus connection and mounting bolts for tightness.

- Check that all wiring connections are tight and all control cabling is intact.

CAUTION: Be sure the condition which caused the overheating has been corrected before reenergizing.

6. Disassembly and Reassembly Steps

To ensure that the charger is powered off, the upstream circuit breaker/isolating switch of the charger must be cut off for component replacement. At the same time, the AC main circuit breaker and the auxiliary power supply circuit breaker of the charger must be cut off.

6.1 Charging Cable

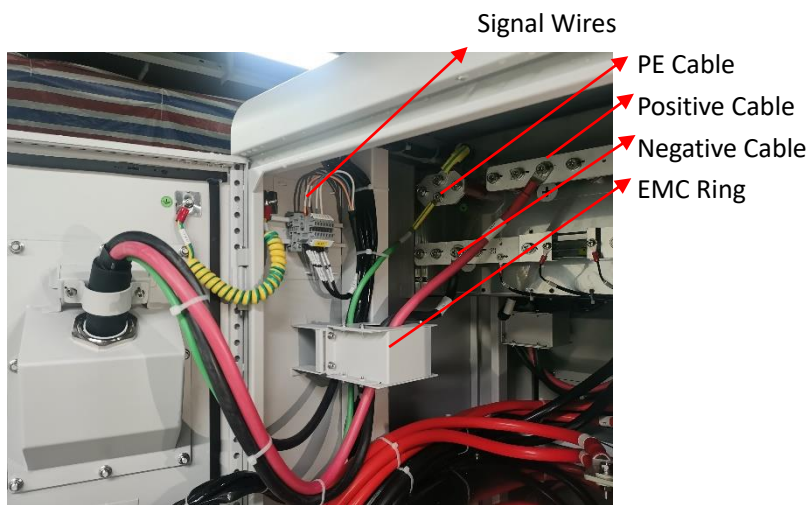

①. Disconnect positive cable, negative cable and PE cable (Take electrostatic discharge precautions before operations).



②. Cut the cable binder and pull out the signal wires from the charging cable to disconnect it (Take electrostatic discharge precautions before operations).



③. Loosen the left and right screws on the cable clamp, and remove the cable clamp.



④. Loosen the fixing bolt on the charging cable, and pull out the charging cable.

6.2 Screen

Steps for screen module replacement (Before replacement of the screen module, make sure to stop all charging processes, disconnect the external power supply, and perform power-off protection.)

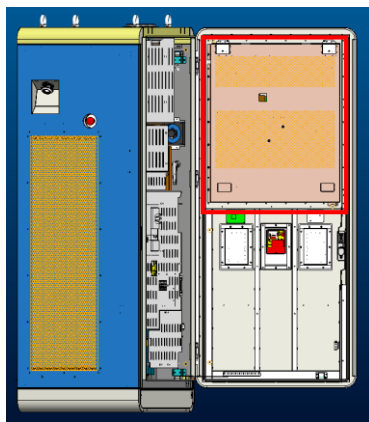

①. Open the front door of the cabinet and find the TCU cover (framed part in the above diagram). Avoid direct exposure to wind and rain when the cabinet door is opened.

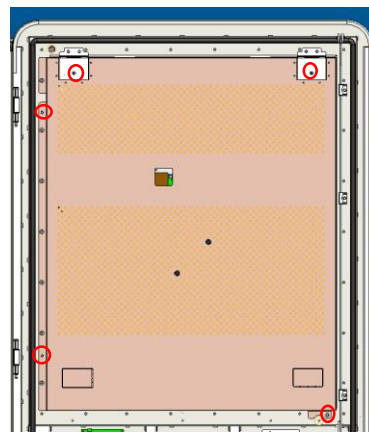

②. Remove five M4 flange nuts with a 7 mm socket wrench, and keep the removed nuts and TCU cover for future use.



③. Remove the wire slot cover (Keep it for future use), disconnect terminals, and pull out wires from slots. Take electrostatic discharge precautions before terminal disconnection.

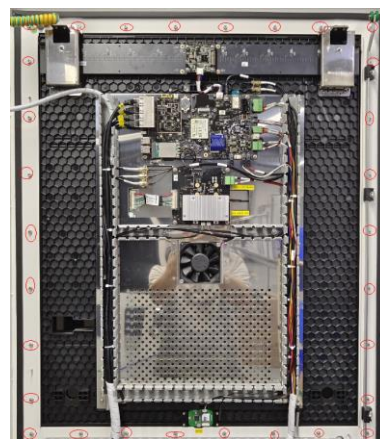

④. Remove thirty M4X10 screws at the positions as shown in the diagram using a Philips screwdriver or an electric screwdriver, and keep them for future use.

6.3 Filter

a) (Old) Left Door Dustproof Cotton Replacement

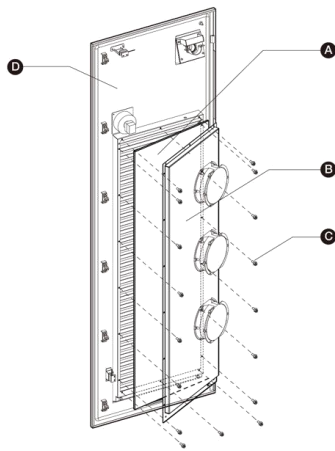

Operations for Dustproof Cotton Replacement:

- ① Before cleaning and replacement of the dustproof cotton, make sure to stop all charging processes, disconnect the external power supply, and perform power-off protection.
- ② Open the left door of the charger. Avoid direct exposure to wind and rain when the door is open.
- ③ Remove the M4 combination screws (C) with a Phillips screwdriver or 7 mm socket wrench, remove the fan mounting plate (B), and take out the white dustproof cotton. Make sure that the removed fan mounting plate is not placed directly on the ground. It should be hung on the left door panel or held by hand to prevent the fan wires from being pulled out and the sheet metal components being scratched and damaged.
- ④ Clean the ash and dust on the waterproof shutter of the door panel. Install the new white dustproof cotton, and the fan mounting plate, which is fixed with M4 combination screws.
- ⑤ Close the left door of the charger.

b) (Old) Right Door Dustproof Cotton Replacement

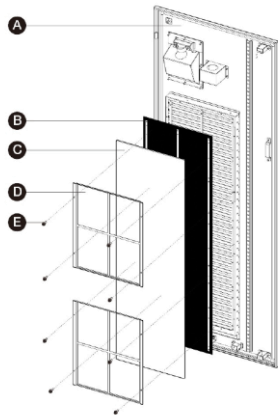

Operations for Dustproof Cotton Replacement:

- ① Before cleaning and replacement of the dustproof cotton, make sure to stop all charging processes, disconnect the external power supply, and perform power-off protection.
- ② Open the right door of the charger. Avoid direct exposure to wind and rain when the door is open.
- ③ Remove the M4 combination screws (E) with a Phillips screwdriver or 7 mm socket wrench, remove the fan mounting plate (D), and take out the white dustproof cotton.
- ④ Clean the ash and dust on the waterproof shutter of the door panel. Install the new white dustproof cotton, and the fan mounting plate, which is fixed with M4 combination screws.
- ⑤ Close the right door of the charger.

c) (Interim) Left Door Dustproof Cotton Replacement

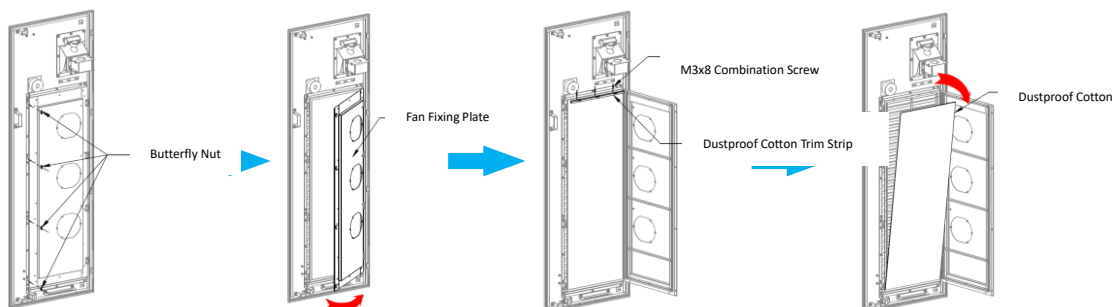

Operations for Dustproof Cotton Replacement:

- ① Before cleaning and replacement of the dustproof cotton, make sure to stop all charging processes, disconnect the external power supply, and perform power-off protection.
- ② Open the left door of the charger. Avoid direct exposure to wind and rain when the door is open.
- ③ Remove four butterfly nuts by hand (or using a needle nose plier) and rotate the fan fixing plate to open it. Remove the M3x8 screws with a Phillips screwdriver, remove the dustproof cotton trim strip, and then take out the dustproof cotton.
- ④ Clean the ash and dust on the waterproof shutter of the door panel. Install the new dustproof cotton in the opposite way as shown in Step 3, and tighten the butterfly nut to complete the dustproof cotton replacement
- ⑤ Close the left door of the charger.

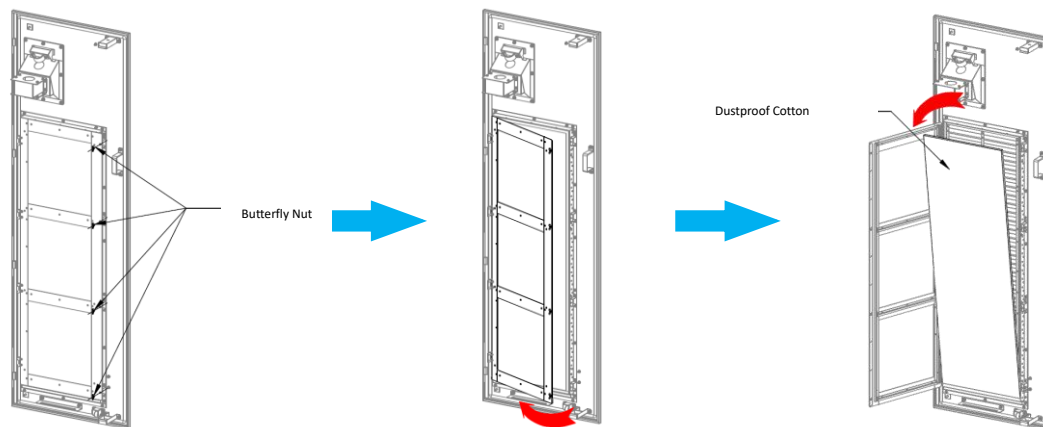

Operations for Dustproof Cotton Replacement:

- ① Before cleaning and replacement of the dustproof cotton, make sure to stop all charging processes, disconnect the external power supply, and perform power-off protection.
- ② Open the right door of the charger. Avoid direct exposure to wind and rain when the door is open.
- ③ Remove four butterfly nuts by hand (or using a needle nose plier) and rotate the fan fixing plate to open it. Take out the dustproof cotton.
- ④ Clean the ash and dust on the waterproof shutter of the door panel. Install the new filter in the opposite way as shown in Step 3, and tighten the butterfly nut to complete the filter replacement.
- ⑤ Close the right door of the charger.

e) (New) Left Door Filter Replacement

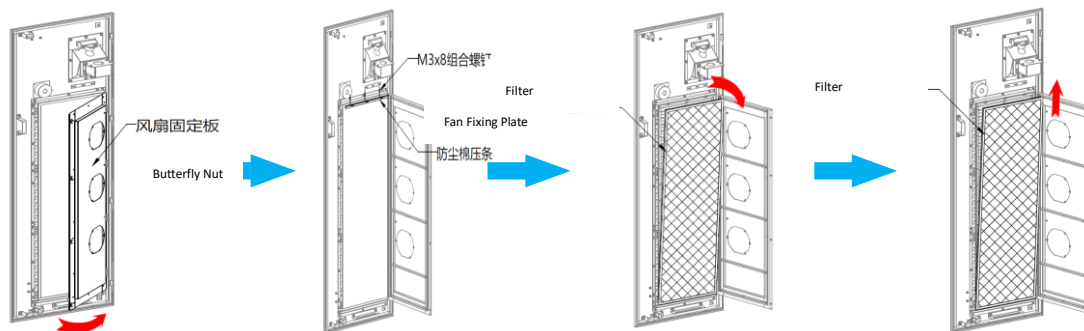

Operations for Filter Replacement:

- ① Before cleaning and replacement of the dustproof cotton, make sure to stop all charging processes, disconnect the external power supply, and perform power-off protection.
- ② Open the left door of the charger. Avoid direct exposure to wind and rain when the door is open.
- ③ Remove four butterfly nuts by hand (or using a needle nose plier) and rotate the fan fixing plate to open it. Take out the top end of the filter and then lift it upwards to remove the whole filter.
- ④ Clean the ash and dust on the waterproof shutter of the door panel. Install the new filter in the opposite way as shown in Step 3, and tighten the butterfly nut to complete the filter replacement.
- ⑤ Close the left door of the charger.

f) (New) Right Door Filter Replacement

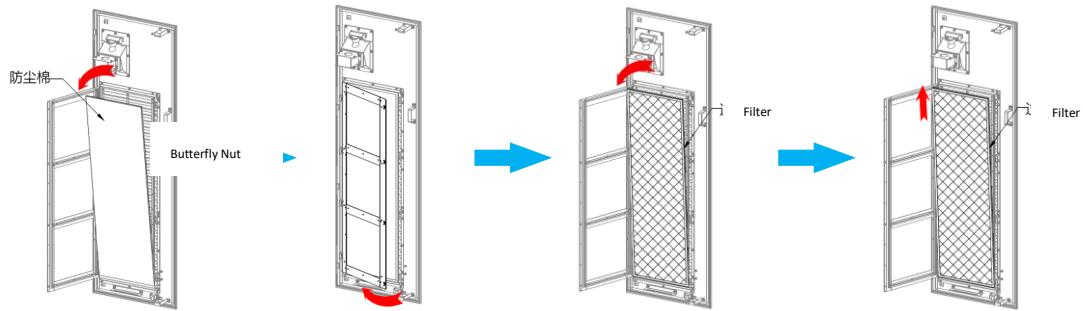

Operations for Filter Replacement:

- ① Before cleaning and replacement of the dustproof cotton, make sure to stop all charging processes, disconnect the external power supply, and perform power-off protection.
- ② Open the right door of the charger. Avoid direct exposure to wind and rain when the door is open.
- ③ Remove four butterfly nuts by hand (or using a needle nose plier) and rotate the fan fixing plate to open it. Take out the top end of the filter and then lift it upwards to remove the whole filter.
- ④ Clean the ash and dust on the waterproof shutter of the door panel. Install the new filter in the opposite way as shown in Step 3, and tighten the butterfly nut to complete the filter replacement.
- ⑤ Close the right door of the charger.

6.4 Charging Module

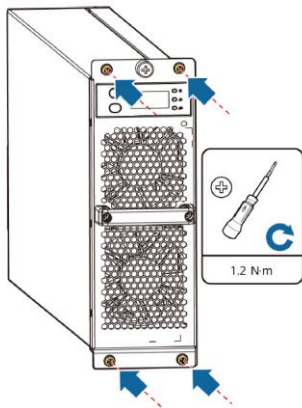





Operations for Charging Module Replacement:

- ① Before replacement of the charging module, make sure to stop all charging processes, disconnect the external power supply, and perform power-off protection.
- ② Open the right door of the charger. Avoid direct exposure to wind and rain when the door is open.
- ③ Remove the four M4x10 external hexagon combination screws with a Phillips screwdriver, and loosen the captive screws to pull out the charging module.
- ④ After putting the new charging module back into the charger, re-tighten the captive screws and four M4x10 external hexagon combination screws.
- ⑤ Close the right door of the charger.

Set the address for the charging module newly installed step by step shown below.

Procedure	Instruction	Nixie tube display
-----------	-------------	--------------------

0	Initial status of the module after powered on	Voltage:0V 
1	Press the down button twice to switch to the hardware address display interface	Adr static status display 
2	Press the down button for 3 seconds to switch to the hardware address display interface	The hardware address is statically displayed in decimal notation. The address is shown "6" (default value) in the interface below 
3	Press the down button for 3 seconds to switch to the hardware address setting interface	One of the high, middle, and low digits blinks in decimal notation, the lowest digital "6" blinks as shown below. 
4	Press the up button to switch the high, middle or low position, Press the down button to adjust the value.	The address after adjustment, one of the high, middle, and low digital flashes, the address is set to 8 as shown below. (Take the charger with power more than 160kW for example.) 

5	Press the down button for 3 seconds to save the settings. The operation is completed.	The address is static displayed; Then return to the voltage display interface. The voltage is 0V as shown below.
---	---	--



6.5 Contactor

6.6 AC Contactor and DC Contactor

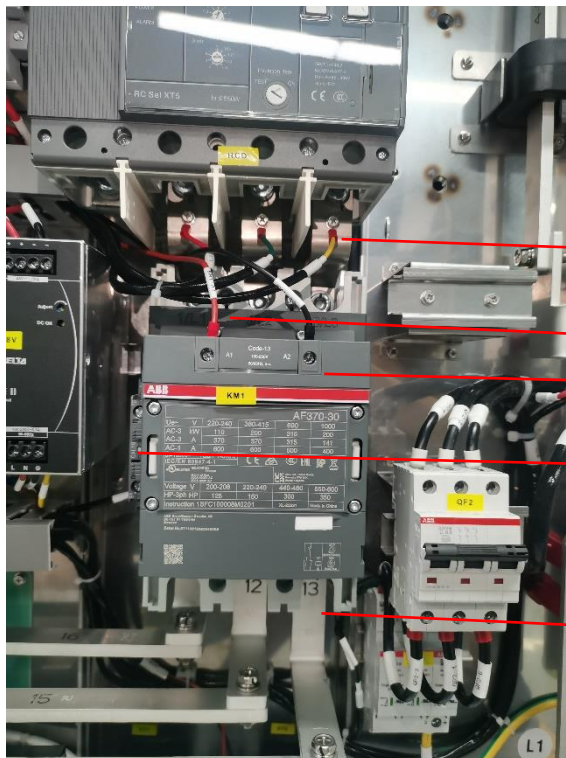

AC Contactor Input Copper Busbar

AC Contactor Control Wire

AC Contactor

AC Contactor Feedback Wire

AC Contactor Output Copper Busbar



Operations for AC Contactor Replacement:

- ① Before replacement of the AC contactor, make sure to stop all charging processes, disconnect the external power supply, and perform power-off protection.
- ② Open the front door of the charger. Avoid direct exposure to wind and rain when the door is open.
- ③ Loosen the studs on the upper and lower copper busbars of the AC contactor with an Allen wrench, and remove the input and output copper busbars for the AC contactor.
- ④ Loosen the control wire and feedback wire of the AC contactor.
- ⑤ Loosen the screws that fix the bottom of the AC contactor on the cabinet sheet metal, and remove the AC contactor.

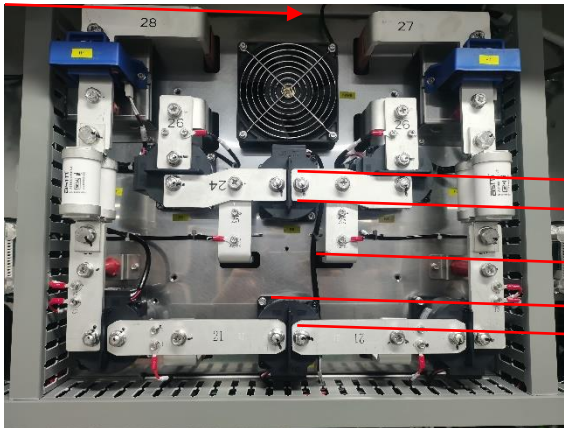

- DC Copper Busbar
- DC Contactor
- DC Contactor Signal Wire
- DC Contactor Fixing Screw
- DC Contactor

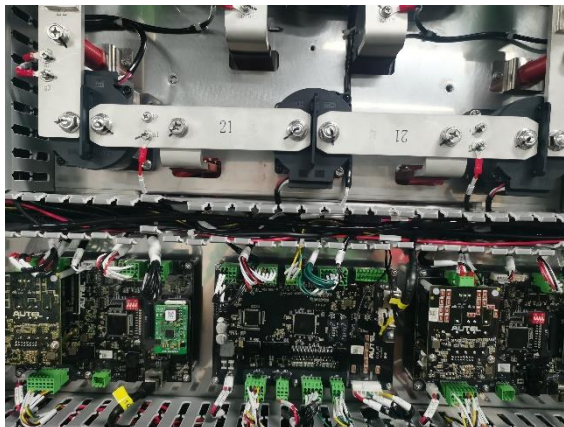

Operations for DC Contactor Replacement:

- ① Before replacement of the DC contactor, make sure to stop all charging processes, disconnect the external power supply, and perform power-off protection.
- ② Open the front door of the charger. Avoid direct exposure to wind and rain when the door is open.
- ③ Loosen the screws that fix the copper bars on both sides of the DC contactor, and remove the copper busbars.
- ④ Remove the lower wire slot cover, find the inserting terminal buried in the wire slot along the signal wire of the DC contactor and disconnect the terminal.
- ⑤ Loosen the screws that fix the AC contactor on the cabinet sheet metal, and remove the AC contactor.