



XJ Transfer Case Skid Installation Instructions

Thank you for purchasing our XJ Transfer Case Skid!

Installation Notes:

- This product is designed to fit Jeep Cherokees 2 door or 4 doors 1984-2001 with the NP231 Transfer Case.
- During installation some cutting and/or grinding may be required depending on your vehicle.
- This transfer case skid is made to work with the factory cross member and factory control arms.
- Further modifications may be required to work with any long arm kit that uses the factory crossmember.
- This skid can fit with our XJ Frame Stiffeners. This is a very tight fit, some modifications may be necessary, and two jacks will be required to fit the skid completely.

Tools required:

- 9/16" Socket and Wrench
- 11/16" Wrench
- 3/8" Drill Bit
- 17/32" Drill Bit
- 1/4" Drill Bit
- Jack(s)
- 21/64" (.3281") Drill Bit *Frame Stiffener Installation*

Contents of each box

Bill Of Materials For (BOM Part# and Description)			
QTY	Part Number	Etch Number	Description
1	B4W188772	772 CBW	XJ Transfer Case Skid
6	37C125HCS8Y		3/8"-16 x 1-1/4" Hex Head Grade 8 Bolt
2	37C300KFCS		3/8"-16 x 3" Flat Head Socket Cap Screw 18-8 SS
2	37CNNE0Y/GC		3/8"-16 Nylock Nut
8	37NWSAFY		3/8" SAE Washer
6	FPCALFST616150		3/8"-16 Rivet Nut Insert
1	43CNFH8Y		7/16"-14 Nut
4	94077A105		3/8"-16 x 1-1/2" Hex Washer Thread Forming Screw

Transfer Case Skid with Frame Stiffeners Install Notes:

If you do not have frame stiffeners installed continue to Step 1

- The skid with frame stiffeners will be a very tight fit together. When jacking the skid in place, you may need another jack to fully place one side of the skid. Make sure the skid sits tight up against the front lip of the crossmember and tight and flat up underneath it. A rubber mallet may be used to maneuver the skid to its proper place.
- When installing the transfer case skid with frame stiffeners already on your Jeep, make sure all welds are ground flush with the stiffeners, leaving a clean flat surface.
- 3/8" thread forming screws will be used to install the skid instead of the 3/8" rivet nuts on the side of the frame (see Step 2). Using an 21/64" (.3281") drill bit, drill out the 4 holes on the side of the frame, going through the stiffener and frame.
- Starting with a pilot bit and working your way up to the correct size will help make sure the hole is straight and round to ensure a proper install of the thread forming screw.

Step 1:

With the Jeep parked on a level surface, jack the skid plate underneath the Jeep with the front lip tight up against the front of the crossmember. Ensure you are jacking the skid directly under the crossmember so the skid will sit flat underneath it.

Step 2:

Once you have checked the fitment of the skid, go ahead and start drilling pilot holes using the 1/4" drill bit for the 2 holes on each side of the uni-frame for the rivet nuts (see image below). If you have a transfer case drop, you will want to drill the pilot hole towards the top of the slot. If you do not have one, drill the pilot hole towards the bottom of the slot.

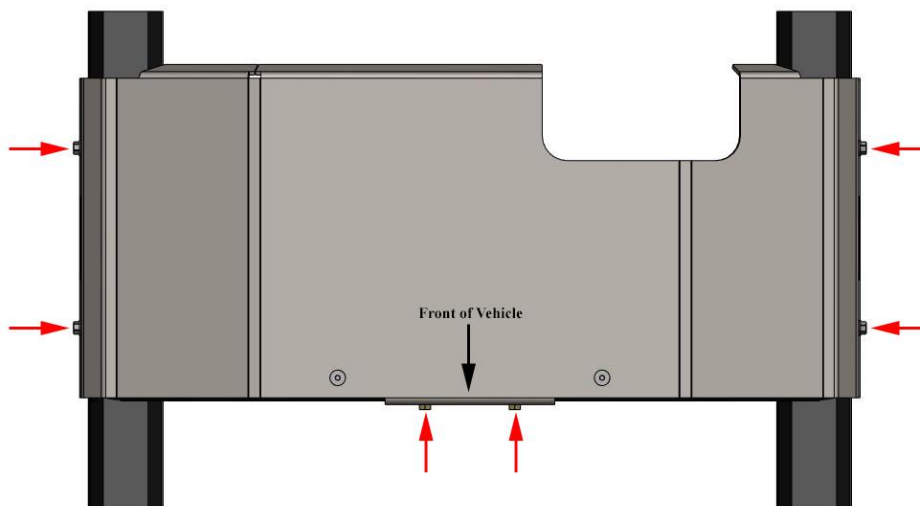

Step 3:

Make sure the skid is tight up against the front of the crossmember and drill two pilot holes using the 1/4" drill bit for the front two rivet nuts for the front lip bolts (see image above).

Step 4:

Remove the skid to prep and paint it.

Step 5:

Using a 17/32" drill bit, drill out the 6 pilot holes from Step 2 and 3. Be sure these are straight, clean holes to ensure the rivet nuts will install properly.

Step 6:

Using one of the 3/8" bolts, two 3/8" washers, and the provided 7/16" nut, as shown below, install the six rivet nuts. Push the rivet nut into the respected holes in the frame. With a 11/16" wrench, hold the 7/16" nut and using a 9/16" wrench or socket, tighten the bolt until the rivet nut is fully installed. The bolt will become very tight and there should be no wiggle or twist to the rivet nut.

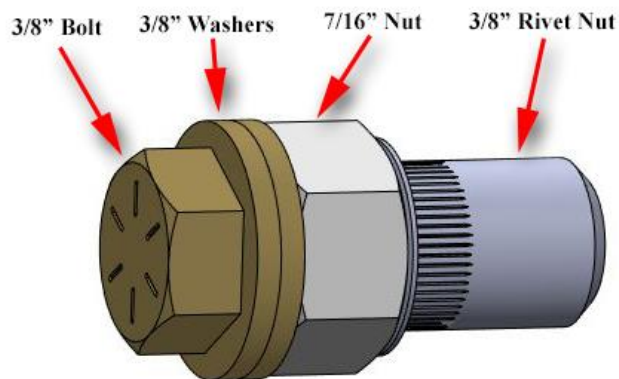

Step 7:

Once the rivet nuts are all properly installed, jack the skid back in place. Thread the six 3/8" bolts and washers into the sides and front of the skid. Leave the four side bolts loose and snug up the two front lip bolts so there is not gap between the front lip of the skid and crossmember.

Step 8:

Make sure the front lip of the skid is tight up against the crossmember. With a 3/8" drill bit, drill through the bottom two holes in the skid into the bottom and top of the crossmember. Make sure to keep the drill in the center and straight so the bolt will sit flush. Loosely install the 3/8" flat head cap screws, washers, and nuts.

Step 9:

Fully tighten all bolts and nuts, starting with the front bolts on the skid lip, then the bottom flat head cap screws, and lastly the four side bolts.

Professional Services Disclaimer:

The content of all pages of this website (collectively, the "Website"), such as text, graphics, images, information and other material (collectively, "Content") is for informational purposes only. Any information furnished on this Website is not intended nor implied to be automotive advice and is not intended to replace personal consultation with a qualified automotive service technician, mechanic, or similar automotive professional.

Barnes 4WD has not examined the Content for accuracy, timeliness, completeness, appropriateness, or helpfulness. Barnes 4WD does not endorse any specific tests, products, procedures, opinions, or other information that may be mentioned on this Website. Your reliance upon information and Content obtained by you at or through this Website is solely at your own risk. IN NO EVENT SHALL BARNES 4WD BE LIABLE OR OTHERWISE RESPONSIBLE FOR ANY DAMAGE OR INJURY (INCLUDING DEATH) TO YOU, OTHER PERSONS, OR PROPERTY ARISING FROM ANY USE OF ANY PRODUCT, INFORMATION, IDEA, OR INSTRUCTION CONTAINED IN THE CONTENT.

BARNES 4WD DOES NOT MAKE ANY REPRESENTATION OR WARRANTY, EXPRESS OR IMPLIED, AT LAW OR IN EQUITY, WITH RESPECT TO ANY PRODUCT FEATURED ON THE WEBSITE, INCLUDING WITHOUT LIMITATION WITH RESPECT TO MERCHANTABILITY, FITNESS FOR ANY PARTICULAR PURPOSE, VALUE, VALIDITY, OR ENFORCEABILITY, AND ANY AND ALL SUCH OTHER REPRESENTATIONS OR WARRANTIES ARE HEREBY EXPRESSLY DISCLAIMED.