

## Jeep TJ One Ton Sterling Axle Swap Truss Kit

Thank you for purchasing our Jeep TJ One Ton Axle Swap Truss Kit!

### Installation notes:

- Installation of this kit requires welding
- This kit will require relocation of the fuel tank or a custom fuel tank for clearance of the differential cover
- The factory rear sway bar is not compatible with this axle, a custom sway bar is required.
- This kit is intended to convert your rear suspension to a 4 link with triangulated upper links. Custom upper links and custom frame mounts will need to be fabricated for a complete installation.
- Refer to your factory service manual for information regarding the removal of any factory components.
- This kit is designed to be used with the full float 10.25 or 10.5 Sterling rear axle from an F250 or F350 pickup.
- The Sterling axle has an 8-6.5" bolt pattern, this will not match the factory TJ 5-4.5" pattern.
- Some axles will require the vent port on the axle tube to be relocated
- This kit does not have any provisions for brake lines, drive shafts, or the parking brake. These items are the responsibility of the end user.

### Tools Required:

- Welding machine with the capability to weld at least 3/8" thick steel
- Various hand tools for the removal and installation of existing components
- Grinder
- Cutting torch, plasma cutter or other appropriate cutting tool
- Angle finder
- Tape measure

### Step 1:

Remove all factory brackets from the Sterling axle, none of the factory bracketry will be used.

### Step 2:

Place the coil spring base gussets on the bottom side of the truss. Each side consists of 3 pieces, place the parts in locations in the image below, all parts will tab to the truss top. Repeat this step for both sides of the truss.

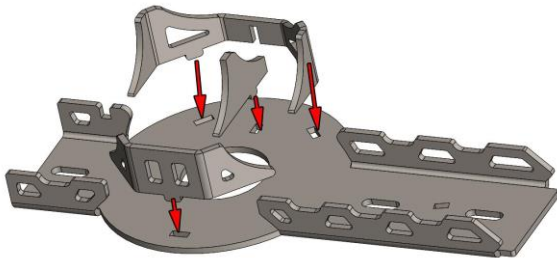

### Step 3:

Place the axle on jack stands or another sturdy work surface. Rotate the axle until the desired pinion angle for your Jeep is achieved. Place the truss top on the axle and level (parallel to the ground). Measure from the backing plate flanges to the ends of the truss, and center the truss on the axle. Once truss is positioned properly, place tack welds to secure it to the axle tubes. Place the truss side assemblies on both sides of the truss center. The side assemblies should contact the truss top and be leveled, then tack weld in place. Depending on pinion angle some minor grinding may be required for proper fitment.

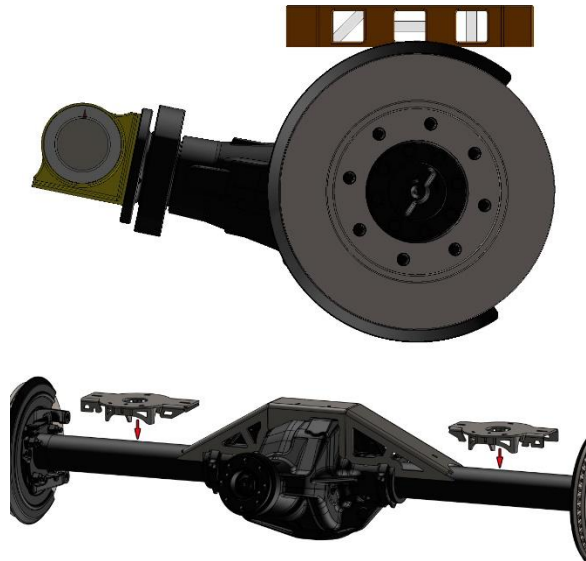

### Step 4:

Assemble the coil spring locators. Place the two provided 3/8" nuts on the coil locator caps, lining up the hole in the nut and the cap. Weld into place. Place the cap/nut assembly in the center halves, flush, and weld into place on the inside of the sleeve.

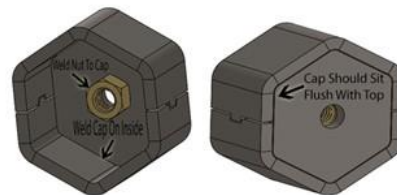

Step 5:

Place the coil spring locator assemblies from step 4 in the holes on either end of the truss. Push the assemblies down until they contact the axle tube and weld into place.

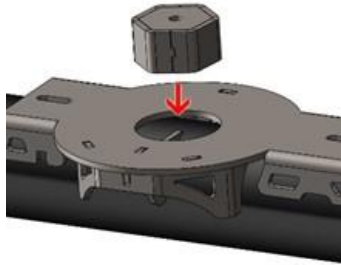

Step 6:

Install the upper control arm brackets. The brackets should angle out away from the pinion when installed properly. The brackets have tabs on the bottom that will insert into slots in the truss top. Place the brackets on both sides and tack weld in place.



Step 8:

Install lower control arm brackets. The lower control arm brackets have a tab on the top leg that keys into a slot in the side of the truss. The front face of the tab should be flush with the face of the truss. Install the brackets on both sides of the truss and tack weld into place. When installed properly the lower control arm mounts should angle in towards the pinion.

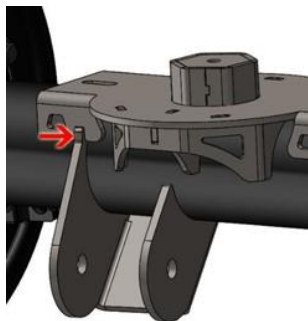

Step 9:

Install the shock mounting brackets, the brackets will need to be installed with 37-3/4" between centers of the brackets. Find the centerline of the axle by measuring from backing plate flange to backing plate flange mark this position. Using the mark as a guide place the shock brackets 18-7/8" from center. The brackets should be rotated back (towards the rear of the axle) 20°, however in some applications the rotation may need to be changed to obtain proper clearance for the shocks.



Step 10:

Test fit the axle under the vehicle to verify that all suspension components are in their proper location and have adequate clearance to all other components on the vehicle.

Step 11:

Remove the axle from the vehicle. Weld the truss to the axle, and weld all seams not welded in previous steps. It is not necessary to weld the truss to the axle in all areas of contact. We recommend making staggered welds, weld a 1"-2" long weld, skip an area about the same length, and add another weld. We also recommend moving around on the axle while welding to avoid concentrating heat in one area. Take your time and allow plenty of time for the assembly to cool between welds.

Congratulations you have completed the installation of your axle truss!

Professional Services Disclaimer:

The content of all pages of this website (collectively, the "Website"), such as text, graphics, images, information and other material (collectively, "Content") is for informational purposes only. Any information furnished on this Website is not intended nor implied to be automotive advice and is not intended to replace personal consultation with a qualified automotive service technician, mechanic, or similar automotive professional. Barnes 4WD has not examined the Content for accuracy, timeliness, completeness, appropriateness, or helpfulness. Barnes 4WD does not endorse any specific tests, products, procedures, opinions, or other information that may be mentioned on this Website. Your reliance upon information and Content obtained by you at or through this Website is solely at your own risk. IN NO EVENT SHALL BARNES 4WD BE LIABLE OR OTHERWISE RESPONSIBLE FOR ANY DAMAGE OR INJURY (INCLUDING DEATH) TO YOU, OTHER PERSONS, OR PROPERTY ARISING FROM ANY USE OF ANY PRODUCT, INFORMATION, IDEA, OR INSTRUCTION CONTAINED IN THE CONTENT. BARNES 4WD DOES NOT MAKE ANY REPRESENTATION OR WARRANTY, EXPRESS OR IMPLIED, AT LAW OR IN EQUITY, WITH RESPECT TO ANY PRODUCT FEATURED ON THE WEBSITE, INCLUDING WITHOUT LIMITATION WITH RESPECT TO MERCHANTABILITY, FITNESS FOR ANY PARTICULAR PURPOSE, VALUE, VALIDITY, OR ENFORCEABILITY, AND ANY AND ALL SUCH OTHER REPRESENTATIONS OR WARRANTIES ARE HEREBY EXPRESSLY DISCLAIMED.