

Jeep TJ Dana 44 Swap Kit With Truss

Thank you for purchasing our Jeep TJ Dana 44 Swap Kit!

Installation Notes:

- Installation of product requires a trained welder!
- Refer to your factory service manual for information regarding removal of the factory rear axle.
- An adjustable track bar is recommended.
- This kit contains no provisions for brake line, driveshaft, and emergency brake modifications. They are the responsibility of the end user.

Tools Needed

- Welding machine with the capability of welding at least 1/4" thick steel
- Tape measure
- Angle Finder
- Level
- Appropriate safety equipment
- Clamps

Step 1:

You will need to establish the existing pinion angle of the axle in your vehicle. This number will be unique to your Jeep, depending on the amount of lift you have, type of rear driveshaft, and several other factors. This number usually ranges from 10-20 degrees. With vehicle sitting level and at ride height measure the pinion angle of your existing axle with an angle finder. After removing only the driveshaft, place an angle finder on the front flat face of the pinion yoke, and record this number.

Step 2:

Place your axle on a sturdy work surface. Place the axle at the same pinion angle as the axle in your Jeep. Three jack stands can be used, one under each axle tube and one under the pinion to hold the pinion angle.

Step 3:

Tack weld the top, sides, and the two gussets of the truss together. The tabs on the angle section of the side plates will appear not to line up. You will need to flex the top of the truss to line the tabs up to insert in the holes. After the center 3 tabs are inserted in the truss top use a clamp to pull the outer two tabs in. Repeat this for the other side plate.

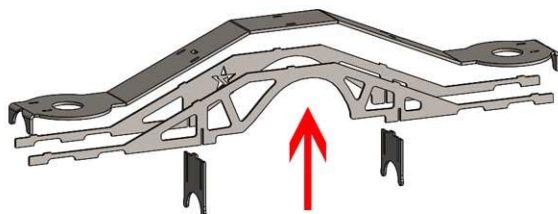

Step 4:

Place the assembly of the pieces that you just tacked together on top of the axle. Center the assembly by measuring from the backing plates on the axle to the truss top. Use a level or angle finder on top of the truss to level the assembly on the axle.

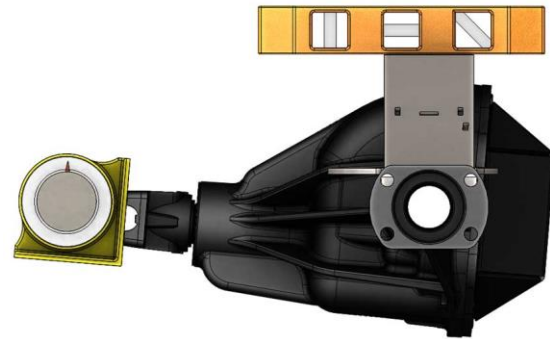

Step 5:

Clamp the truss to the axle tube to insure that the truss is pulled all the way against the axle tubes. Tack weld the truss to the axle tubes in several locations and remove the clamps.



Step 6:

The 3/8" nuts provided in the kit need to be welded to the coil spring caps. Center one nut on one coil spring cap and weld the nut to the cap, repeat this step for the other coil spring cap. Now the assembly is ready to be welded to the center halves. Insert the cap in the center halves and weld the cap to the center halves on the inside.

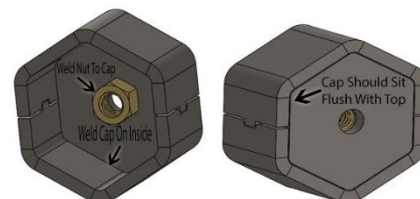

Step 7:

The sway bar brackets will also need nuts welded to the backside. Place one 3/8" nut over each hole on the backside of each bracket and weld in place.



Step 8:

Add the upper control arm brackets to the truss. Place the upper control arm brackets on top of the truss as shown in the image below. Slide the brackets down the truss until they are in their correct position. When placed correctly they should contact the truss and the axle tubes, tack both brackets in place.

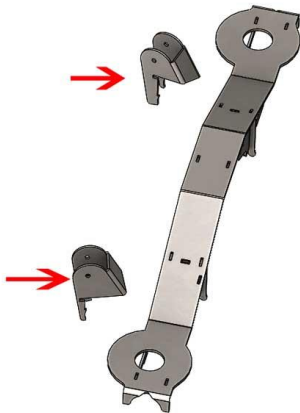

Step 9:

Install the track bar bracket. The track bar bracket will be placed on the backside of the truss, it will locate with a tab on the bottom of the bracket in a slot on the top of the truss. Tack weld the bracket when positioned correctly.

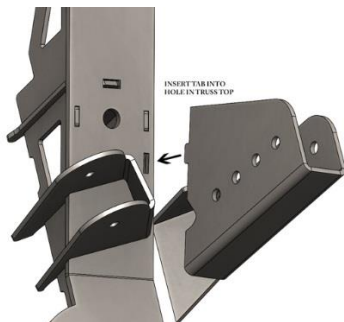

Step 10:

Install center assembly from step 7. Place the two assemblies in the holes on either side of the truss and tack weld in place.

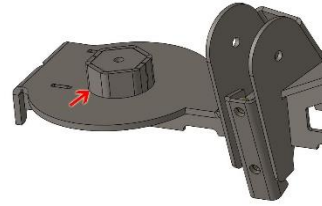

Step 11:

Install the sway bar bracket assemblies from step 8. Place the brackets on the axle tube inside the upper control arm brackets. The sway bar brackets should be vertical and the upper inside corner should touch the inside of the upper control arm bracket on the side closest to the pinion. When positioned correctly tack weld the brackets to the axle tube.

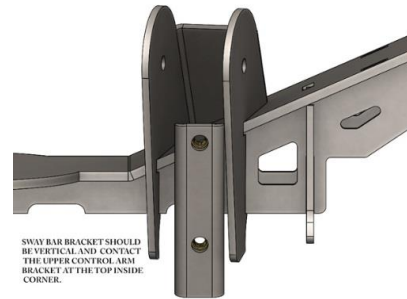

Step 12:

Install the lower control arm brackets. Place the lower control arm brackets on the axle tube, the brackets should point in towards the pinion when on the correct side. Line the upper outside corner of the lower control arm bracket up with the corner of the leg on the truss top. Once lined up, the bracket is positioned correctly. Tack weld the brackets in place.

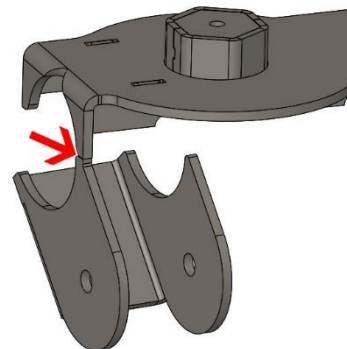

Step 13:

Install the shock brackets on the axle. Using the measurements obtained from your factory axle as a guide. Tack weld the shock brackets to the axle.

Step 14:

With all components tack welded in place, test fit the axle under the Jeep. Determine which hole location in the track bar bracket is correct for your Jeep. **Trim the excess height off from the track bar bracket, failure to trim the bracket can cause damage to the Jeep!** Cycle the rear suspension and verify that there is not any interference with any of the components of the Jeep.

Step 15:

Remove the axle from the Jeep and finish welding the brackets and truss. Do not concentrate welding heat on one location of the axle at a time. Weld in small 1"-2" increments and move around on the axle housing after each weld. Weld the truss and brackets to the tubes of the axle first, then weld the brackets to the truss and the truss together. It is not recommended to weld all seams on the truss 100%, staggered welds are recommended.

Make a weld a few inches long and leave an area un-welded between each weld, this will minimize heat input and prevent warpage.

Step 16:

When installing the axle in the Jeep the factory rear Jeep sway bar will be re-used. Install the coil spring retainer plates after the coil springs are installed.

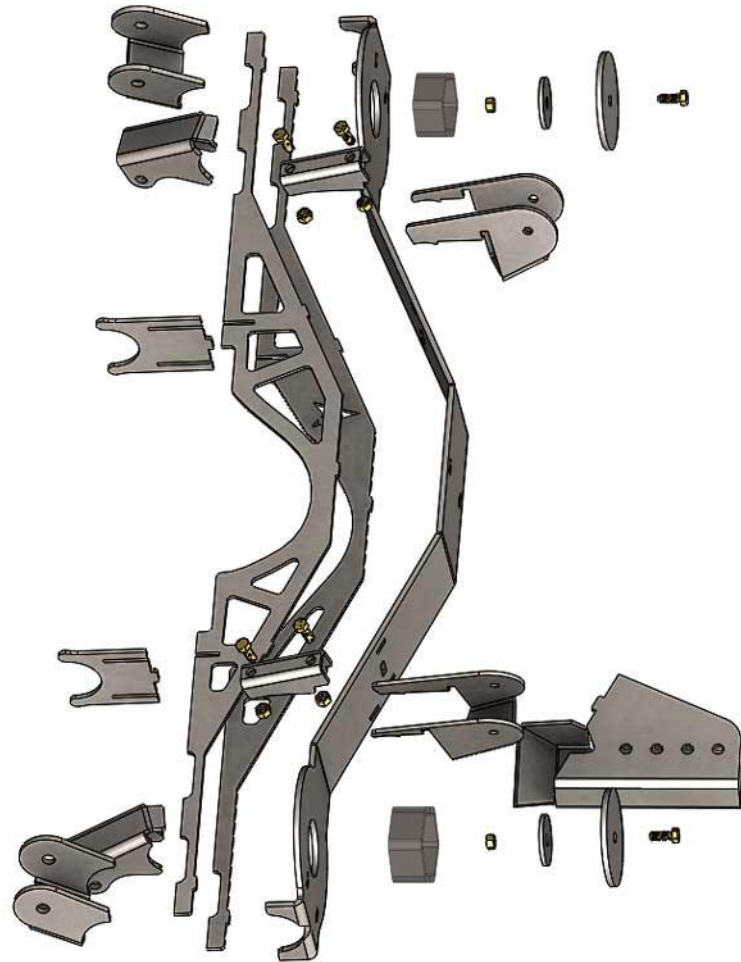

Professional Services Disclaimer:

The content of this Website, such as text, graphics, images, information and other material (collectively, "Content") is for informational purposes only. Any information furnished on this Website is not intended nor implied to be automotive advice and is not intended to replace personal consultation with a qualified automotive service technician, mechanic or similar automotive professional.

Barnes 4WD has not examined the Content for accuracy, timeliness, completeness, appropriateness, or helpfulness. Barnes 4WD does not endorse any specific tests, products, procedures, opinions, or other information that may be mentioned on this Website. Your reliance upon information and Content obtained by you at or through this Website is solely at your own risk. IN NO EVENT SHALL BARNES 4WD BE LIABLE OR OTHERWISE RESPONSIBLE FOR ANY DAMAGE OR INJURY (INCLUDING DEATH) TO YOU, OTHER PERSONS, OR PROPERTY ARISING FROM ANY USE OF ANY PRODUCT, INFORMATION, IDEA, OR INSTRUCTION CONTAINED IN THE CONTENT.