



Jeep XJ Rear Bumper Welders Kit

Fabrication Notes

Thank you for purchasing this product!

Installation Notes:

- This kit is designed to be compatible with 1984-2001 Jeep Cherokee XJ models.
- This kit requires welding, automotive mechanical knowledge, and general fabrication skills, it should only be done by qualified individuals.
- The components of this kit will need to be painted or powder coated during installation.
- Refer to your factory service manual to remove any factory components.
- We recommend tack welding the assembly and test fitting before fully welding the bumper.

Tools required:

- Welding machine with the capability to weld at least ¼" thick steel.
- Various hand tools
- Grinder

Contents of box

Bill Of Materials for B4WK12872			
QTY	Part Number	Etch Number	Description
1	B4W188422	422 B	XJ Rear Bumper
1	B4W188C24	C24 B	XJ Rear Sheet Metal Bumper Driver Wing
1	B4W188C25	C25 B	XJ Rear Sheet Metal Bumper Passenger Wing
2	B4W188C26	C26	XJ Rear Sheet Metal Bumper Hitch Gusset
1	B4W188C27	C27 B	XJ Rear Bumper Tie In Bracket Driver
1	B4W188C28	C28 B	XJ Rear Bumper Tie In Bracket Passenger
1	B4W250A98	A98 B	XJ Rear Bumper Bracket Driver
1	B4W250A99	A99 B	XJ Rear Bumper Bracket Passenger
2	B4W25001	01	Receiver Chain loop
2	B4W500120	120	XJ Rear Bumper Recovery Bracket
1	RECEIVER1	NA	4" Receiver tube
8	.100C350BHFOY/6921	NA	M10-1.5 x 35mm Hex Flange Bolt Yellow Zinc
6	50C150HCS8Y	NA	1/2"-13 X 1-1/2" Hex Head Bolt Yellow
8	50NWSAFY	NA	1/2" SAE Flat Washer Yellow Zinc
2	50CNNE0Y/GC	NA	1/2"-13 Nylon Lock Nut

Grind these tabs off each side of the bumper.

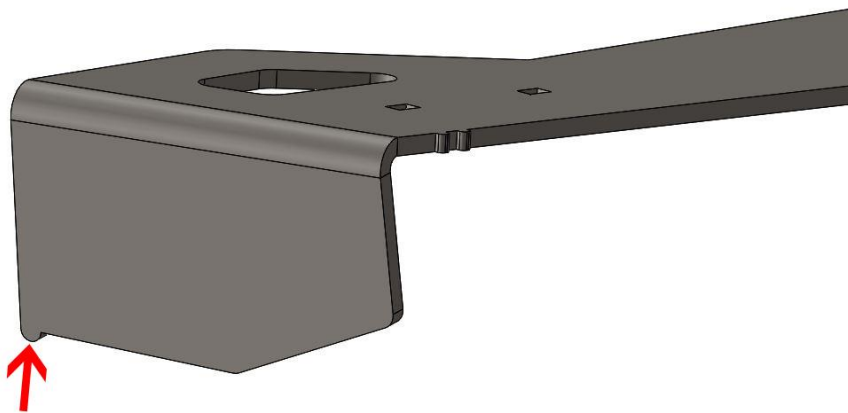

All parts will tab into the main shell. Align edges and tack weld in place.

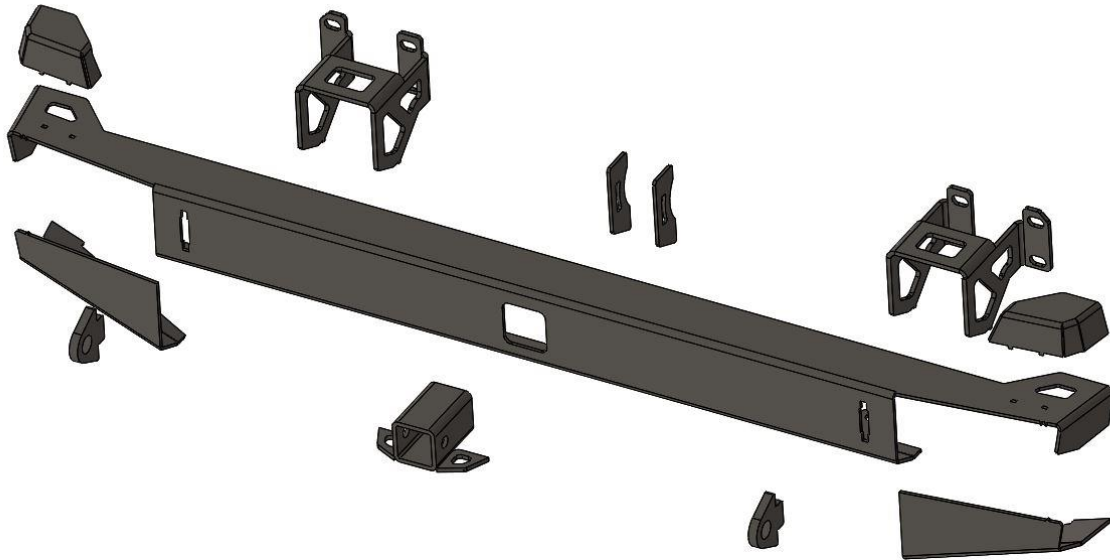

Assemble the hitch as shown below and tack weld in place

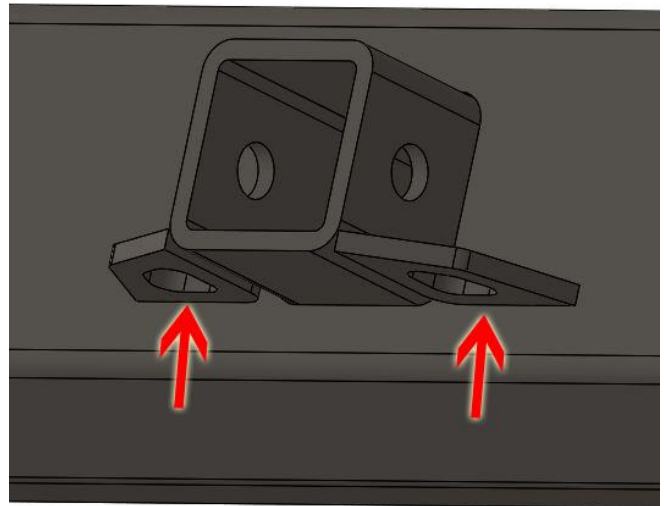
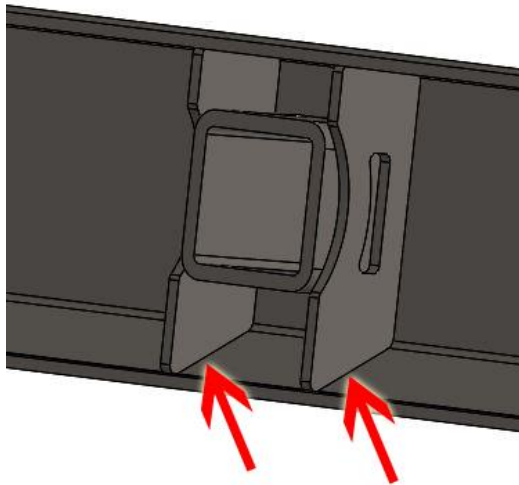

Assemble tie in gussets.



Test fit the bumper and finish weld all seams.

Professional Services Disclaimer:

The content of all pages of this website (collectively, the "Website"), such as text, graphics, images, information and other material (collectively, "Content") is for informational purposes only. Any information furnished on this Website is not intended nor implied to be automotive advice and is not intended to replace personal consultation with a qualified automotive service technician, mechanic, or similar automotive professional.

Barnes 4WD has not examined the Content for accuracy, timeliness, completeness, appropriateness, or helpfulness. Barnes 4WD does not endorse any specific tests, products, procedures, opinions, or other information that may be mentioned on this Website. Your reliance upon information and Content obtained by you at or through this Website is solely at your own risk. IN NO EVENT SHALL BARNES 4WD BE LIABLE OR OTHERWISE RESPONSIBLE FOR ANY DAMAGE OR INJURY (INCLUDING DEATH) TO YOU, OTHER PERSONS, OR PROPERTY ARISING FROM ANY USE OF ANY PRODUCT, INFORMATION, IDEA, OR INSTRUCTION CONTAINED IN THE CONTENT.

BARNES 4WD DOES NOT MAKE ANY REPRESENTATION OR WARRANTY, EXPRESS OR IMPLIED, AT LAW OR IN EQUITY, WITH RESPECT TO ANY PRODUCT FEATURED ON THE WEBSITE, INCLUDING WITHOUT LIMITATION WITH RESPECT TO MERCHANTABILITY, FITNESS FOR ANY PARTICULAR PURPOSE, VALUE, VALIDITY, OR ENFORCEABILITY, AND ANY AND ALL SUCH OTHER REPRESENTATIONS OR WARRANTIES ARE HEREBY EXPRESSLY DISCLAIMED.