

Jeep Wrangler JK and JKU 2007-2018 Pritchett Canyon Crash Bar Skid Installation Instructions.

Thank you for purchasing our Pritchett Canyon series Crash Bar Skid Plate!

Installation Notes:

- This skid plate is only designed to work with our Pritchett Canyon standard front bumper. This instruction manual assumes that the bumper has already been installed.
- This skid plate will not work with our frame chop Pritchett Canyon series bumper!
- This skid plate will use the front two mounting bolts provided with your winch. If a winch is not installed hardware will need to be sourced.

Tools required:

- Ratchet
- Standard and metric socket set
- Standard and metric combination wrenches
- Standard hex key set

Step 1:

Remove the two front mounting bolts from your winch.

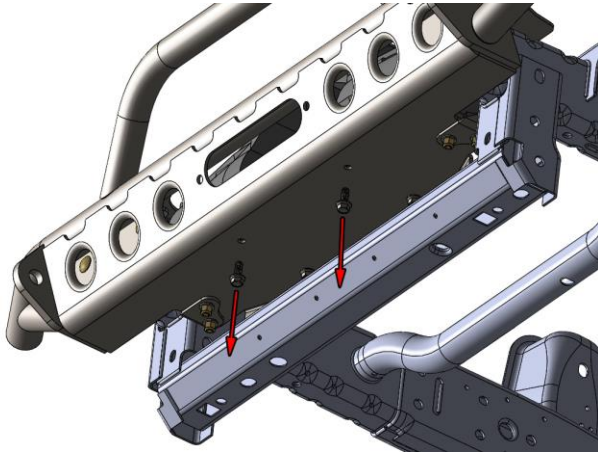

Step 2:

Place the skid plate in position on the bottom of the bumper. Align the slots in the skid with the holes in the bumper where the hardware was removed in step 1. Install the hardware removed in step one hand tight.

SKID PLATE TRANSPARENT FOR CLARITY

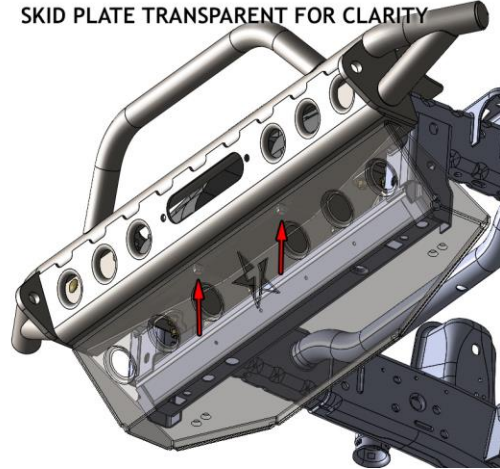

Step 3:

Place the mounting brackets on the rear of the skid plate. 2 Brackets are included in the kit one for each side. Install the countersunk hardware on either side hand tight.

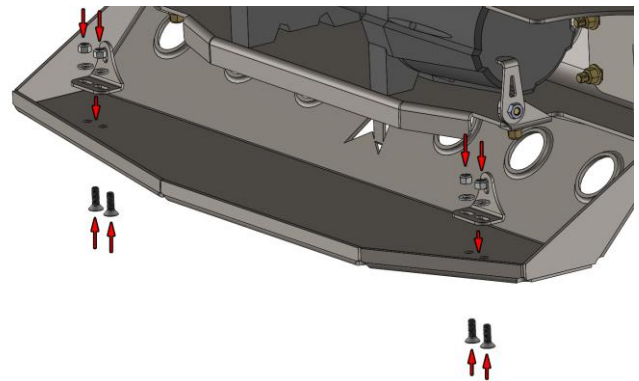

Step 4:

Install the button head bolt through the bracket and into the crash bar. Place a washer and the nylon lock nut on the inside of the crash bar. Repeat this for both brackets.

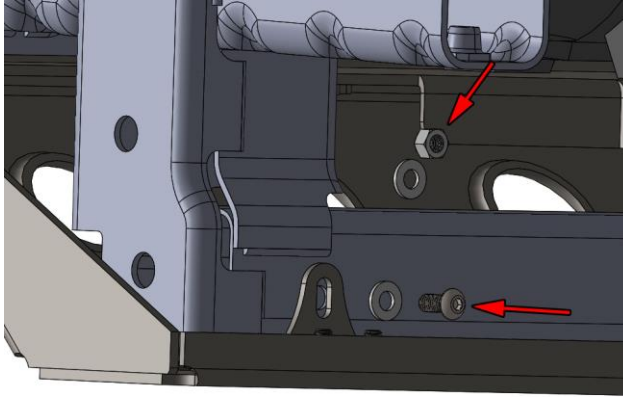

Step 5:

Tighten all provided hardware to 11 Ft-lbs. Refer to the manual for you particular model of winch for torque values for the two front bolts. Re-tighten all hardware 500 miles after installation. Check hardware for proper torque after every 3000 miles.

Congratulations you have completed the installation of you skid plate!

Professional Services Disclaimer:

The content of all pages of this website (collectively, the "Website"), such as text, graphics, images, information and other material (collectively, "Content") is for informational purposes only. Any information furnished on this Website is not intended nor implied to be automotive advice and is not intended to replace personal consultation with a qualified automotive service technician, mechanic, or similar automotive professional.

Barnes 4WD has not examined the Content for accuracy, timeliness, completeness, appropriateness, or helpfulness. Barnes 4WD does not endorse any specific tests, products, procedures, opinions, or other information that may be mentioned on this Website. Your reliance upon information and Content obtained by you at or through this Website is solely at your own risk. IN NO EVENT SHALL BARNES 4WD BE LIABLE OR OTHERWISE RESPONSIBLE FOR ANY DAMAGE OR INJURY (INCLUDING DEATH) TO YOU, OTHER PERSONS, OR PROPERTY ARISING FROM ANY USE OF ANY PRODUCT, INFORMATION, IDEA, OR INSTRUCTION CONTAINED IN THE CONTENT.

BARNES 4WD DOES NOT MAKE ANY REPRESENTATION OR WARRANTY, EXPRESS OR IMPLIED, AT LAW OR IN EQUITY, WITH RESPECT TO ANY PRODUCT FEATURED ON THE WEBSITE, INCLUDING WITHOUT LIMITATION WITH RESPECT TO MERCHANTABILITY, FITNESS FOR ANY PARTICULAR PURPOSE, VALUE, VALIDITY, OR ENFORCEABILITY, AND ANY AND ALL SUCH OTHER REPRESENTATIONS OR WARRANTIES ARE HEREBY EXPRESSLY DISCLAIMED.