

Jeep TJ, LJ, MJ, XJ, and ZJ Passenger Axle Upper Control Arm Bracket

Thank you for purchasing our Passenger Axle Upper Control Arm Bracket!

Installation Notes:

- Installation of product requires a trained welder.
- Refer to the factory service manual for your vehicle for removal and installation of any factory components.

Tools Required

- Welding machine with the capability of welding at least  $\frac{1}{4}$ " thick steel
- Proper cutting tool (grinder, plasma cutter, cutting torch)
- Tape measure
- Angle Finder
- Appropriate safety equipment

Step 1:

Place the metal tube in the provided bracket. Center the tube in the bracket  $\frac{1}{4}$ " from the edge on both sides, and weld around the outside of the tube.

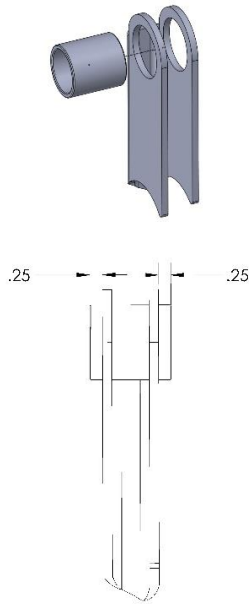

Step 2:

With the vehicle properly supported remove the passenger upper control arm.

Step 3:

Due to variations in models, it is recommended to measure the location and angle of the existing upper control arm bracket on the axle. After measurements have been recorded, remove the bracket from the axle with the cutting tool of your choice and grind the axle tube smooth.

Step 4:

Place the welded assembly from step 1 on the axle. Using an angle finder position the bracket  $5^\circ$  back from the differential cover mounting surface, and  $5''$  from the inside of the coil spring mount. The bracket is cut at the proper angle to locate at  $12^\circ$  in relation to the coil spring mount. Verify the above listed dimensions match the measurements taken in step 3.

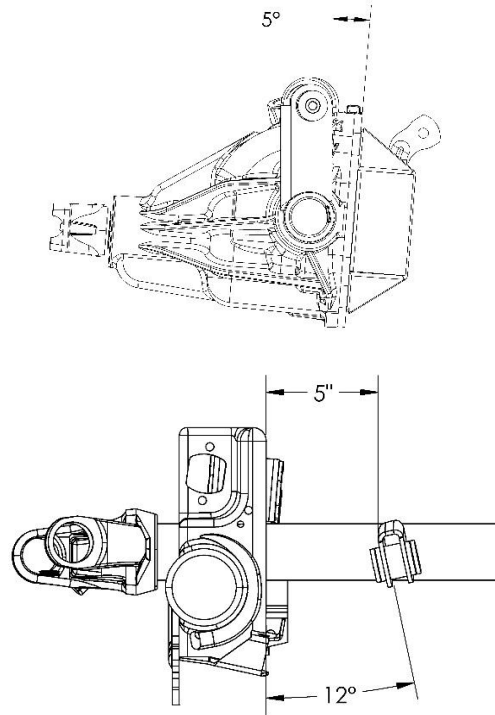

Step 5:

Tack weld the bracket to the axle tube and verify proper fitment of the upper control arm.

Step 6:

Place the included gussets on either side of the bracket, parallel to the axle tube. Finish weld the bracket and the gussets to the axle tube, and to each other.

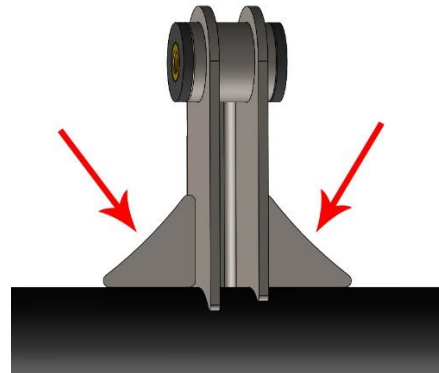

Step 7:

Allow the assembly to cool, and install the provided polyurethane bushings and inner sleeve in the bracket.

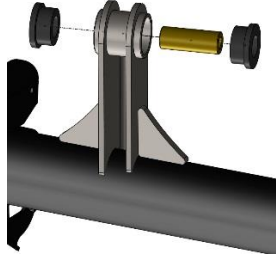

Step 8:

Install the upper control arm back on the vehicle.

Congratulations you have completed the installation of your passenger upper control arm mount!

Professional Services Disclaimer:

The content of this Website, such as text, graphics, images, information and other material (collectively, "Content") is for informational purposes only. Any information furnished on this Website is not intended nor implied to be automotive advice and is not intended to replace personal consultation with a qualified automotive service technician, mechanic or similar automotive professional.

Barnes 4WD has not examined the Content for accuracy, timeliness, completeness, appropriateness, or helpfulness. Barnes 4WD does not endorse any specific tests, products, procedures, opinions, or other information that may be mentioned on this Website. Your reliance upon information and Content obtained by you at or through this Website is solely at your own risk. IN NO EVENT SHALL BARNES 4WD BE LIABLE OR OTHERWISE RESPONSIBLE FOR ANY DAMAGE OR INJURY (INCLUDING DEATH) TO YOU, OTHER PERSONS, OR PROPERTY ARISING FROM ANY USE OF ANY PRODUCT, INFORMATION, IDEA, OR INSTRUCTION CONTAINED IN THE CONTENT.